



SIMRAD

A KONGSBERG Company

TP10, TP20 & TP30 Tillerpilot Service Manual

Simrad Navico Ltd

Star Lane, Margate, Kent CT9 4NP, UK
Telephone +44 (0) 1843 290290
Facsimile +44 (0) 1843 290471
E-Mail : sales@simrad-navico.co.uk

CONTENTS

- 1 INTRODUCTION
 - 1.1 Electronics PCBs
 - 1.2 Mechanical Components
- 2 OPERATION
- 3 ASSEMBLY INSTRUCTIONS
 - 3.1 Tillerpilot TP10
 - 3.2 Tillerpilot TP20
 - 3.3 Tillerpilot TP30
- 4 MECHANICAL ASSEMBLY DRAWINGS
 - 4.1 General Assembly : TP10 (E03504)
 - 4.2 General Assembly : TP20 (E03505)
 - 4.3 General Assembly : TP30 (E03506)
- 5 CIRCUIT DESCRIPTIONS
 - 5.1 Tillerpilot TP10 PCB
 - 5.2 Tillerpilot TP20 / TP30 PCB
 - 5.3 Hall Effect PCB
- 6 CIRCUIT DIAGRAMS
 - 6.1 Circuit Schematics
 - 6.2 Component Lists and Layouts
- 7 PROGRAMMING AND CONFIGURATION
- 8 FAULT FINDING
 - 8.1 Common User Faults
 - 8.2 Common Technical Faults
- 9 SPARE PARTS DETAIL
- 10 TECHNICAL NOTES
 - PS 139 Identification of Tillerpilot variants
 - PS 140 Improved bonding of drive pulley to motor drive shaft

© 2000 Simrad Navico Ltd



SIMRAD

A KONGSBERG Company

TP10, TP20 & TP30 Tillerpilot Introduction

1 INTRODUCTION TO THE TP10, TP20 & TP30 TILLERPILOTS

The TP10, TP20 and TP30 Tillerpilots combine highly sophisticated electronics with advanced software and powerful mechanical drives to provide accurate and reliable steering performance under a variety of different conditions with minimal current consumption.

TP10 - is suitable for tiller steered sailing yachts up to 10M (34 Ft) in length.

TP20 - offers the same facilities as the TP10 and is fully NMEA compatible. Options offered include connection to an external compass via the proprietary high speed CANBUS interface and also to a wind sensor or navigational receiver via the inbuilt NMEA0183 input. Additional remote control facilities are also available using the HR20 hand remote or the HC30 hand controller.

TP30 - offers the same facilities as the TP20 with an improved re-circulating ball screw drive and is suitable for tiller steered sailing yachts up to 12.8M (42 Ft) in length.

The main components of the Tillerpilot are described below:

1.1 Electronics PCBs

- a. TP10 PCB (TP10 only) [E03181](#)
- b. TP30 PCB (TP 20 & TP30) [E03178](#)

1.2 Mechanical Components

- a. General Assy : TP10 [E03504](#)
- b. General Assy : TP20 [E03505](#)
- c. General Assy : TP30 [E03506](#)



SIMRAD

A KONGSBERG Company

TP10, TP20 & TP30 Tillerpilot Calibration

2 CALIBRATING THE TP10, TP20 AND TP30

Excerpts from the [TP10](#) operation manual (also applies to the [TP20](#) & [TP30](#) models)

3.2 Calibration Mode

To adjust the Gain and Seastate settings of the Tillerpilot (refer to sections 2.5 & 2.6), it is necessary to enter Calibration Mode, which can be done whilst the Tillerpilot is in either Standby or Autopilot Mode.

Press and hold the **TACK** key, followed by the **CAL** key (Fig 3.3). The Starboard green LED will illuminate to indicate that the pilot is in Gain Mode. To toggle between Gain and Seastate Mode, press the **TACK** key (Fig 3.4). The Port red LED will illuminate to indicate Seastate Mode.

3.3 Adjusting Gain

When Gain Mode is selected (indicated by the Starboard green LED illuminated), the Cal LED will flash and a repeated sequence of beeps will be heard. The number of flashes and beeps in the sequence indicates the level of the Gain setting.

To increase the Gain press the **Starboard** key the required number of times, to a maximum level of 9 (Fig 3.5). To decrease the Gain press the **Port** key the required number of times, to a minimum level of 1.

For example, if the Gain was set at 4 (indicated by a sequence of four flashes of the Cal LED and four beeps), and the Gain needed to be increased to 7, pressing the **Starboard** key three times would adjust the Gain accordingly. The Cal LED would then flash seven times and seven beeps would be heard.

3.4 Adjusting Seastate

When adjusting Seastate (indicated by the Port red LED illuminated), the Seastate level is indicated by the number of audible beeps and flashes of the Cal LED. No beeps or flashes of the Cal LED indicates that the Tillerpilot is set to automatic seastate (see section 2.6).

To switch from Manual to Auto Seastate and increase the Seastate level, press the **Starboard** key the required number of times to a maximum level of 9. To decrease the Seastate press the **Port** key the required number of times, to a minimum level of 0 - which will switch the Tillerpilot back to Auto Seastate.

To confirm Gain/Seastate settings and return to Standby Mode, press the CAL key.

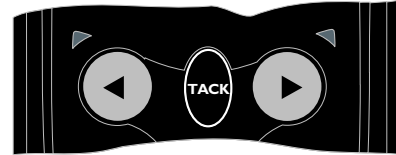

Fig 3.3 - Entering Adjust Mode

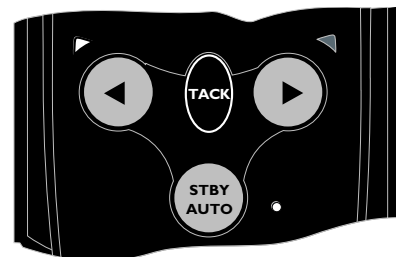

Fig 3.4 - Toggling between Adjust Gain and Seastate

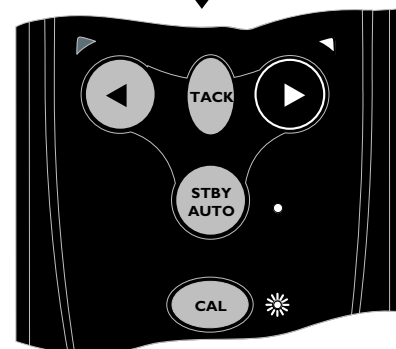

Fig 3.5 - Increasing Gain level

Excerpts from the TP10 operation manual ctd - (also applies to the TP20 & TP30)

SIMRAD

5.2 Auto Compass Calibration

Although the Tillerpilot internal compass is extremely accurate, for long distance sailing it may be necessary to calibrate the compass, to compensate for any deviations caused by objects surrounding it on board the vessel.

With the vessel motoring along slowly (2-3 knots) in calm conditions and the Tillerpilot in Standby Mode, press the **Starboard** key a number of times to induce a slow clockwise rotation of the vessel. Press and hold the **TACK** key, followed by the **Port** and **Starboard** keys simultaneously to enter Auto Compass Calibration Mode (Fig 5.1). The Port and Starboard LEDs will both light. Allow the vessel to turn through a minimum of $1\frac{1}{4}$ turns (450°) in approximately two minutes, during which time the flux-gate compass will automatically calibrate itself.

If the rate of turn or the boat speed is too high, the Port LED will flash (Fig 5.2) indicating that it is necessary to either slow the boat or decrease the angle of turn. If the rate or turn or boat speed is too slow the Starboard LED will flash, indicating that it is necessary to either increase the boat speed or increase the angle of turn. A short beep will indicate that the calibration has been successful, and the Tillerpilot will return to Standby Mode. If the calibration has been unsuccessful after a period of four minutes, a long beep will sound. Try again carefully following the above directions.

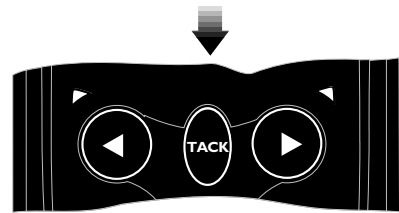
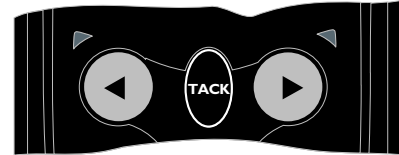

Fig 5.1 - Auto Compass Calibration

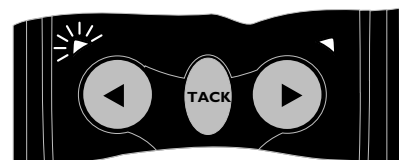

Fig 5.2 - Rate of turn too fast



SIMRAD

A KONGSBERG Company

TP10, TP20 & TP30 Tillerpilot Assembly Instructions

3 ASSEMBLY INSTRUCTIONS

3.1 General Assembly : TP10

Motor and Drive Assembly. Refer to drawing [E03504](#) The Bottom Case Assembly is supplied fitted with appropriate cables. Refer to detail in the drawing and insert the Push Rod Seal E00747, which has a taper inner bore, into the case with the larger bore of the seal facing outwards. Fit "O" Ring 190026, spacer E02870 and End Cap E02495 and push home. Fit Retainer E03084 and secure with 2 screws 200002 to hold the end cap, ensuring it is pushed fully in when the two screws are tightened. Using a small brush, grease the 'trough' area and the bore which houses the seal, O ring and spacer. Insert the Drive Assembly E03264 ensuring that the bearing slots into the bearing housing and the drive belt 280027 is fitted around the pulley. Insert the Motor Assembly E02788 fitted with front and rear Motor Mounts E02502 and E02503 ensuring that the blue wire is uppermost, the motor sits snugly into the bottom of the retaining slot and the drive belt is engaged over the motor drive pulley. Check that the motor, belt and drive screw assembly move freely. Fit Bearing Clamp E02497 on two Nylon Spacers 200115, one on each screw 200137, into the case bottom and secure the bearing with the two screws. Refer to the diagram below and check that the belt tension is within +/- 3mm.

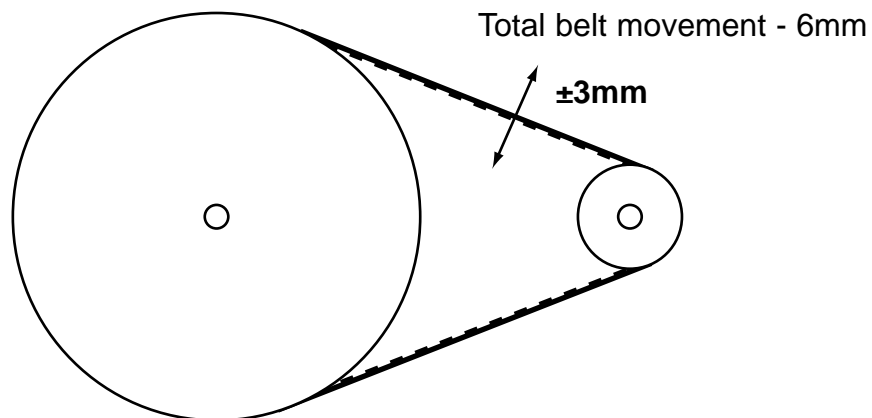

Fit the Tiller Connector E02607 into the end of the Push Rod E02522 and screw in, finger tight.

Hall Effect PCB, Fit the Hall effect PCB onto the 2 pillars using 2 nylon washers 200037 as spacers between the pillars and the PCB, and 2 screws 200139.

Main PCB. Feed the power, motor and feedback leads through the 2 grommets 190036 and the appropriate grommet in the PCB Assembly cover and solder the connections to the PCB. Refer to [drawing](#) and push PCB Assembly firmly onto the four bosses in the PCB Cover E02680. Clip the compass Assembly E02637 into the Drilled PCB Cover E02680, it can only be fitted one way round, ensuring that the lugs on the compass assembly line up with the 2 holes in the PCB cover and push in. Refer to drawing E02587 and ensuring that the wires from the compass to the connector lay over the PCB, insert plug into the socket on the PCB. Ensure all wires are clear of, and not fouling the PCB cover seal, and position the PCB Cover complete with the PCB and compass into the Case Top Assembly E02612. Screw down the PCB cover with 6 screws 200139 and fully tighten. Position the two grommets into case top, and push home into the two slots. Wrap the "Wits" fixing 200196 around the cable loom, and using a screw 200139 fix into the top cover.

Main Seal. Fit the pivot pin into the square section at the rear of the prepared bottom case ensuring that the pin hangs out of the case with the notch on the pivot facing towards the operating rod of the Tillerpilot. Fold the metal pin into its recess in the lower case. Position the Case Seal E02498 onto the case bottom ensuring it is pushed fully into the grooved housing. Carefully lift the case seal from around the area of the pivot pin and using a cotton bud apply Dow Corning 1205 Primer 260029 to the case. Fill a small hypodermic syringe with Dow Corning 3140 Silicone sealant 260001 and run a small bead of sealant completely around the case seal in the area of the square as shown below:

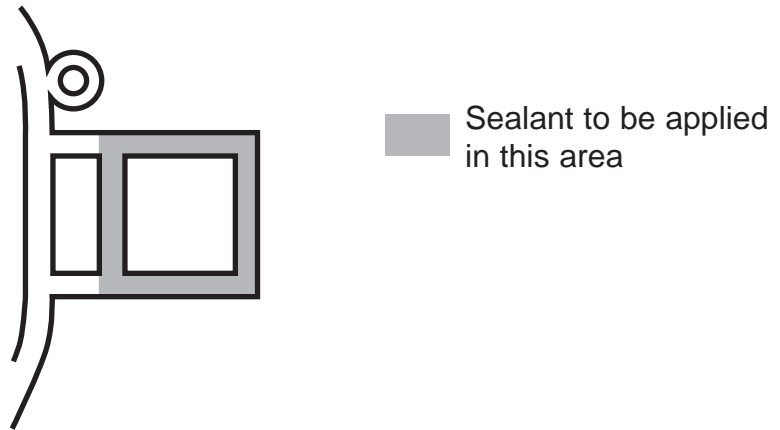

Refit the seal onto the case.

Final Assembly. Carefully position the case top onto the bottom ensuring that the case seal is correctly located all round, squeeze the top and bottom halves of the case together, and fit the 10 screws 200088. Tighten down evenly all round in the sequence shown below:

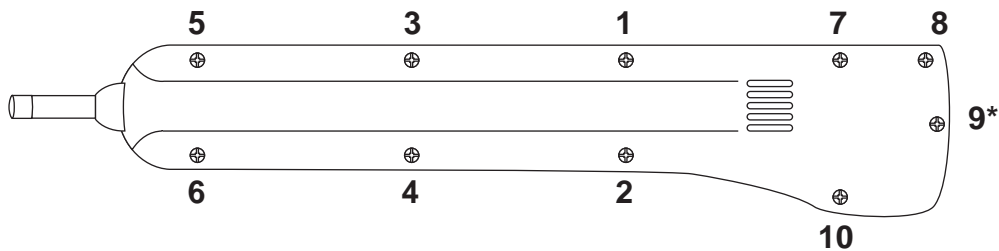

Tighten case screws in sequence 1 to 10

*** Note** - At screw No.9, stop and check lip on top case is correctly located into bottom case before fully tightening up.

Post Assembly Test. Remove the Tiller Connector E02607 and push the Tillerpilot Test Syringe Part No. **TP-SRY** over the end of the Push Rod E02522. Depress the syringe piston and release, the piston should return to its original position indicating that the integrity of the case seal has not been compromised during fitting. Remove the Test Syringe and refit the Tiller Connector.

3.2 General Assembly : TP20

Refer to Drawing No. **E03505**. Assembly is identical to the **TP10** with the following exceptions:

Main PCB E03718. The Main PCB is populated differently to facilitate the processing of NMEA data.

Case Bottom. The case bottom includes a third wiring (communications) loom to carry NMEA data.

PCB Cover E02681. The PCB Cover is drilled with a third access point and grommet to accept the NMEA data leads.

3.3 General Assembly : TP30

Refer to Drawing No. **E03506**. Assembly is identical to the **TP20** with the following exception:

Drive Assembly E02618. The Drive Assembly employs a re-circulating ball screw. The assembly is held in place by the metal mounting plate sitting in the mounting slots in both top and bottom cases and drive belt tension is adjusted by the inclusion of spacing shims **E02754** as required.



SIMRAD

A KONGSBERG Company

TP10, TP20 & TP30 Tillerpilot Mechanical Assembly Drawings

4 MECHANICAL ASSEMBLY DRAWINGS

4.1 General Assembly : TP10 (E03504)

4.2 General Assembly : TP20 (E03505)

4.3 General Assembly : TP30 (E03506)

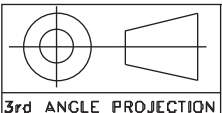

DRAWN IN ACCORDANCE WITH BS 308

DRG No.:
E03504
PRODUCT GROUP : 810
USED ON : TP10

3rd ANGLE PROJECTION

E03507 TP10 CASE TOP ASSEMBLY

E03181 WP/TP/10/100 PCB ASSEMBLY

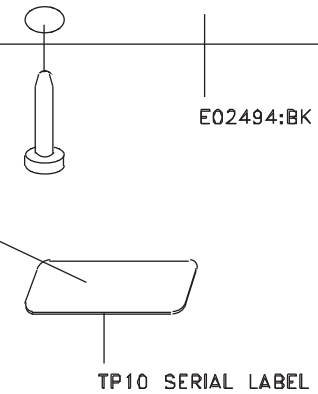
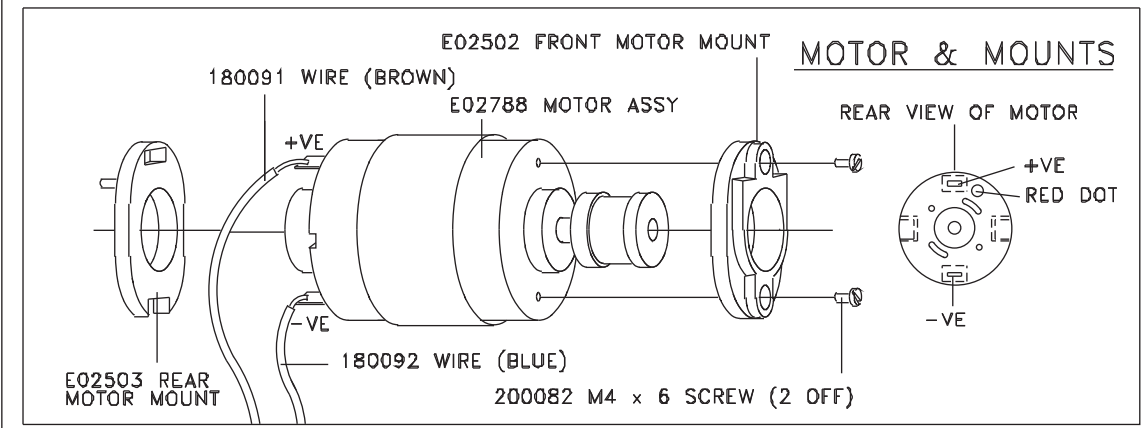
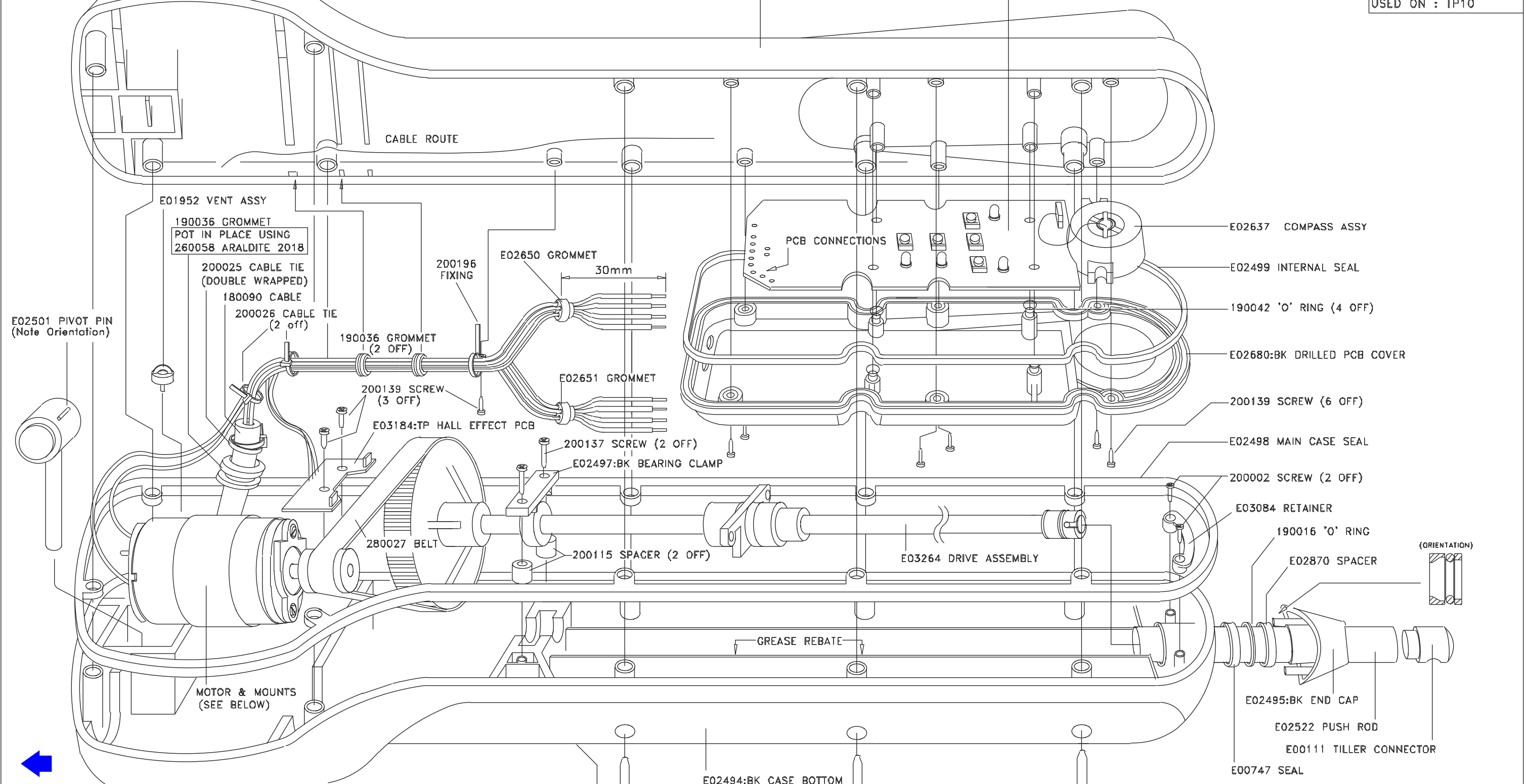

DO NOT SCALE		IF IN DOUBT ASK		1375	3	14/9/99	E03184:TP WAS E03184	
				1312	2	3/3/99	200281 (10 OFF) WERE 200088	
		Mod.No.	Iss.	Date:	Modifications			
SIMRAD A KONGSBERG Company	STAR LANE, MARGATE, KENT CT9 4NP TEL: 01843 290290 FAX: 01843 290471 +44 1843 290290		Drawn:	Checked:	Approved:		Tolerances	ALL DIMENSIONS
	Material:		Date: 3/3/98	Date:	Date:	+ & -		mm
Finish:		COMPUTER GENERATED DRAWING MANUAL MODIFICATION INVALIDATES CAD FILE.		Model:		0. = 0.50		SIMRAD NAVICO 1999
Date: 27/11/98		Original Scale: NTS		Title: GENERAL ASSEMBLY		0.0 = 0.25		
				Drg No.:		0.00 = 0.10		SHT. 1 OF 1
				Issue		ANG. = 0.5°		
				E03504		3		

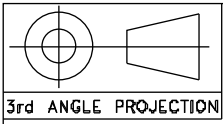

DRAWN IN ACCORDANCE WITH BS 308

DRG No.: **E03505**
 PRODUCT GROUP : 810
 USED ON : TP20

E03508 TP20 CASE TOP ASSEMBLY

E03178 WP/TP/20/30/200CX/300CX PCB ASSEMBLY

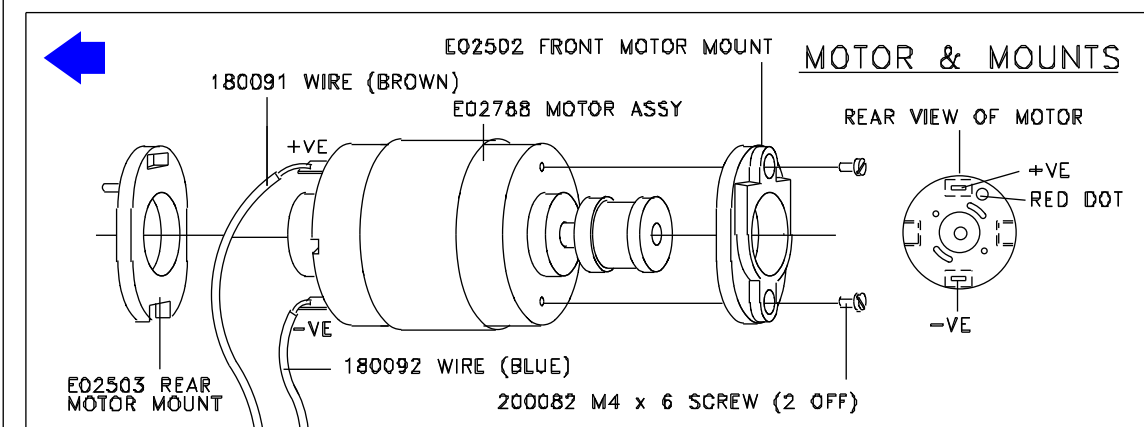
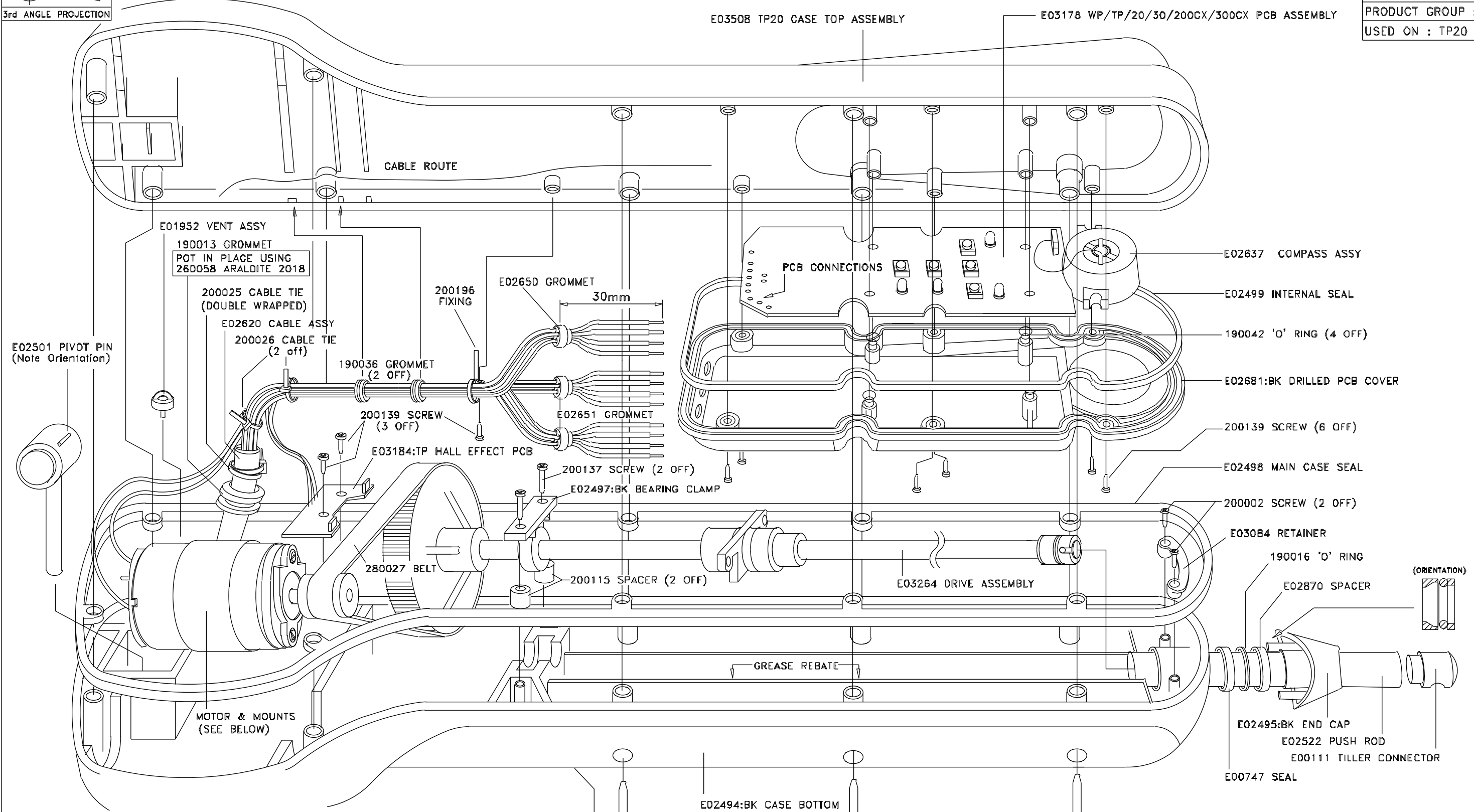

DO NOT SCALE IF IN DOUBT ASK		1375 3 14/9/99	E03184:TP WAS E03184
		1312 2 3/3/99	200281 (10 OFF) WERE 200088
		Mod.No. Iss. Date:	Modifications
SIMRAD A KONGSBERG Company	STAR LANE, MARGATE, KENT CT9 4NP TEL: 01843 290290 FAX: 01843 290471 +44 1843 290290		Drawn: BPL Checked: Approved: Tolerances + & - ALL DIMENSIONS mm
	Date: 27/11/98 Original Scale: NTS		Date: Date: Date: 0. = 0.50 0.0 = 0.25 0.00 = 0.10 ANG. = 0.5°
	Date: 27/11/98 Original Scale: NTS		Date: Date: Date: 0. = 0.50 0.0 = 0.25 0.00 = 0.10 ANG. = 0.5°
TP20		GENERAL ASSEMBLY	
		Title: GENERAL ASSEMBLY	
		Drg No.: E03505 Issue: 3	



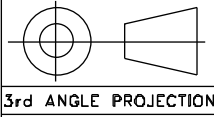

DRAWN IN ACCORDANCE WITH BS 308

E03509 TP30 CASE TOP ASSEMBLY

E03178 WP/TP/20/30/200CX/300CX PCB ASSEMBLY

DRG No.:
E03506

PRODUCT GROUP : 810

USED ON : TP30

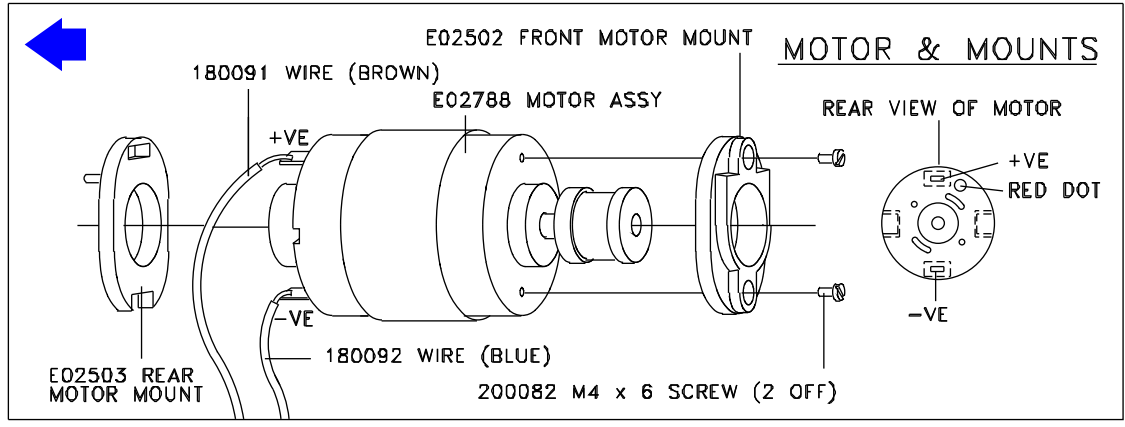
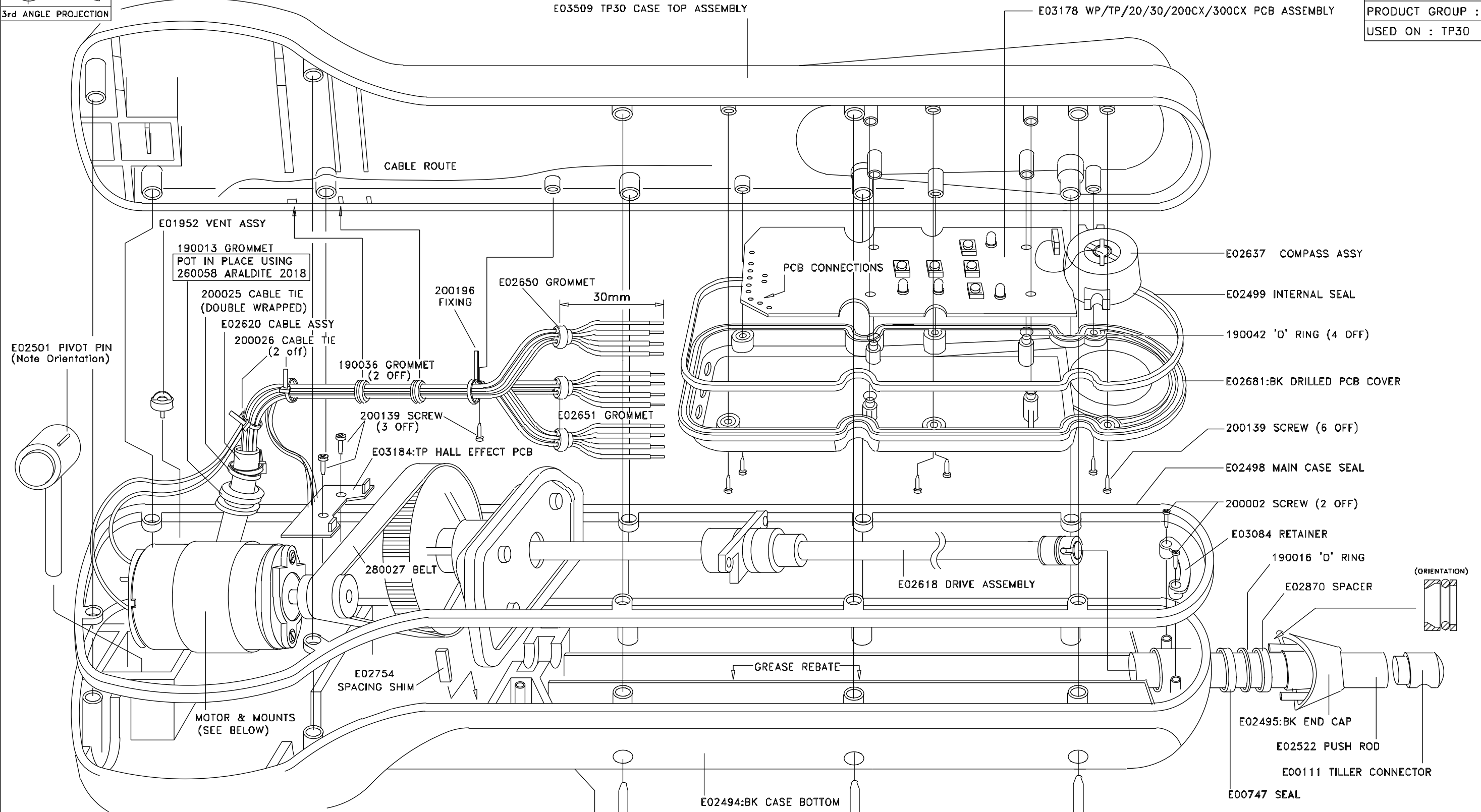

DO NOT SCALE IF IN DOUBT ASK		1375	3	14/9/99	E03184:TP WAS E03184
		1312	2	3/3/99	200281 (10 OFF) WERE 200088
		Mod.No.	Iss.	Date:	Modifications
SIMRAD A KONGSBERG Company	STAR LANE, MARGATE, KENT CT9 4NP TEL: 01843 290290 FAX: 01843 290471 +44 1843 290290		Drawn:	Checked:	Approved:
			Date: 3/3/99	Date:	Date:
	Material:		COMPUTER GENERATED DRAWING MANUAL MODIFICATION INVALIDATES CAD FILE.		
	Finish:		Model: TP30		
Date: 27/11/98		Original Scale: NTS		Title: GENERAL ASSEMBLY	
				Tolerances + & - 0. = 0.50 0.0 = 0.25 0.00= 0.10 ANG. = 0.5°	
				ALL DIMENSIONS mm SIMRAD NAVICO 1999 SHT. 1 OF 1	
				Drg No.: E03506	
				Issue 3	



SIMRAD

A KONGSBERG Company

TP10, TP20 & TP30 Tillerpilot Circuit Descriptions

5 CIRCUIT DESCRIPTIONS

5.1 Tillerpilot TP10 PCB Assembly

Introduction. The PCB Assembly is a generic item which can be used for Wheelpilots WP10 and WP30 and for Tillerpilots TP10, TP20 and TP30. The different versions are created by applying different components to the common PCB. The circuit diagram for the TP10 PCB is given in Drawing No. **E03371**.

Supply and Regulation. The TP10 is designed to work from a 12 V source. Protection against incorrect polarity is provided by D1 and D4. Capacitors C1 and C3 are used as reservoirs to hold up the supply voltage and reduce any supply dips. Protection against over-voltage spikes is provided by Resistor R2 and Zener Diode ZD1 and Regulator REG1 provides a 5V regulated supply. Transient Voltage Suppressor TVS1 protects the MOSFET drive transistors, TR10 to TR13, from voltage spikes greater than +16V.

Microprocessor. Light Emitting Diodes LED1 to LED4 are driven from the microprocessor IC2 Ports P0.0 and P0.2 to P0.4 and turn OFF when the line goes HIGH via the transistor switches TR2 to TR5. When the transistors are off, resistors R32, R34, R36 and R38 provide a low current path for the LEDs to provide low level night illumination. The Audio Resonator AR1 is self resonating and switches ON when Port P0.5 goes HIGH via the transistor switch TR1 and resistors R59 and R60. The control key lines on Ports P4.0 to P4.4 are normally pulled to +5V via resistors R7 to R11 and are “scanned” by the microprocessor to detect if any of the switches have been operated and pulled the line LOW.

The Links, L1, L2 and L3, are used to configure the Microprocessor to either Wheelpilot or Tillerpilot operation and to model versions 10, 20 or 30 in accordance with the table below:

Model	TP 10	WP 10	TP 20	TP 30	WP 30
Link 1	N / C	N / O	N / C	N / C	N / O
Link 2	N / C	N / C	N / C	N / O	N / O
Link 3	N / C	N / C	N / O	N / O	N / O

N / C - Normally Closed (soldered)

N / O - Normally Open (unsoldered)

Microprocessor Reset. Integrated Circuit IC6 is an integrated reset generator for the microprocessor which produces a reset LOW pulse of approximately 50mS duration at switch on and whenever a 5v supply failure occurs. In addition to the reset provided by IC6, the microprocessor has a built in watchdog timer which will create a reset if a software crash occurs for any reason.

Non-Volatile Memory (NVM). Integrated Circuit IC3 provides 1Kbit of E² memory for the retention of important data after power down.

Fluxgate (Compass). Two anti-phase signals are provided from microprocessor Ports P1.7 and P1.6. These signals are buffered by TR15 and TR16 to provide a higher current drive to the excitation coil of the fluxgate. A reference voltage level of +2 volts is provided by R46 and R53 decoupled by C53. The 2 coils, mounted at right angles, provide output signals proportional to the sine and cosine of the Earth's magnetic field. These signals are fed via the electronic switch IC9, to 2 dual slope integrating analogue to digital converters IC7 and IC 8 plus associated components. The outputs of the comparator IC7 are fed to the microprocessor Ports P1.4 and P1.5 which provide input capture facilities. Accurate timing of the conversion is kept by the microprocessor to provide simultaneous precision analogue to digital conversion of both sine and cosine signals to avoid errors created by multiplexing the inputs.

Motor Drive. The motor drive signals (MDRIVE_A and MDRIVE_B) are generated from the microprocessor at Ports P0.7 and P0.6, these lines being LOW when there is no drive and HIGH to drive. The drive outputs control IC10 and IC11 which are comparators set at threshold levels of +4V and +1V produced by the resistor network R71, R72 and R73. The comparators invert the signals and provide the current to switch the MOSFETs in stages which prevents both P and N channel MOSFETs on the same side of the "H-bridge" configuration, (i.e. TR10 and TR11 or TR12 and TR13), being partially switched on at the same time. When there is no drive, both N-channel MOSFETs TR11 and TR13 are switched on giving a direct short across the motor to the 0V line thus providing active braking

Feedback. Mechanical movement is sensed by 2 Hall Effect devices mounted on the Hall Effect PCB (Drawing [E03182](#) refers). The devices are triggered by rotating magnets mounted in the pulleywheel of the Tillerpilot drive assembly to produce quadrature style feedback. The 2 feedback signals, FB1 and FB2 which are at logic levels, are connected to microprocessor ports P1.1 and P1.2.

EMC. Capacitors with values of 100pF, 100nF and 1nF are extensively used to decouple noise from switched data lines. Two A.C. coupled connections labelled "CHASSIS", routed via capacitors C63 and C64, were provided for interconnection to the internal metalwork for EMC purposes. Tests have confirmed that connection is not required.

5.2 Tillerpilot 20 / 30 PCB Assembly

Introduction. The PCB Assembly is a generic item which can be used for Wheelpilots WP10 and WP30 and for Tillerpilots TP10, TP20 and TP30. The different versions are created by applying different components to the common PCB. The circuit diagram for the TP20 / 30 and WP30 PCB is given in Drawing No. **E03372**.

Supply and Regulation. The TP20 and TP30 are designed to work from a 12 V source. Protection against incorrect polarity is provided by D1 and D4. Capacitors C1 and C3 are used as reservoirs to hold up the supply voltage and reduce any supply dips. Protection against over-voltage spikes is provided by Resistor R2 and Zener Diode ZD1 and Regulator REG1 provides a 5V regulated supply. Transient Voltage Suppressor TVS1 protects the MOSFET drive transistors, TR10 to TR13, from voltage spikes greater than +16V.

Microprocessor. Light Emitting Diodes LED1 to LED4 are driven from the microprocessor IC2 Ports P0.0 and P0.2 to P0.4 and turn OFF when the line goes HIGH via the transistor switches TR2 to TR5. When the transistors are off, resistors R32, R34, R36 and R38 provide a low current path for the LEDs to provide low level night illumination. The Audio Resonator AR1 is self resonating and switches ON when Port P0.5 goes HIGH via the transistor switch TR1 and resistors R59 and R60. The control key lines on Ports P4.0 to P4.4, normally pulled to +5V via resistors R7 to R11, are "scanned" by the microprocessor to detect if any of the switches have been operated and pulled the line LOW.

NMEA data in is optically isolated by IC5 and then fed into Port P2.4 of the microprocessor. Transistors TR6, TR7 and TR8 and components D6, D7, D8, R17, R18 and R19 form a switch, protected from high voltages, driven from Port P0.1 of the microprocessor. The switch is used to apply the synchronisation pulse (HR200_SYNC) to the NMEA line for products employing a Hand (Remote) Controller.

The Links, L1, L2 and L3, are used to configure the Microprocessor to either Wheelpilot or Tillerpilot operation and to model versions 10, 20 or 30 in accordance with the table below:

Model	TP 10	WP 10	TP 20	TP 30	WP 30
Link 1	N / C	N / O	N / C	N / C	N / O
Link 2	N / C	N / C	N / C	N / O	N / O
Link 3	N / C	N / C	N / O	N / O	N / O

N / C - Normally Closed (soldered)

N / O - Normally Open (unsoldered)

Microprocessor Reset. Integrated Circuit IC6 is an integrated reset generator for the microprocessor which produces a reset LOW pulse of approximately 50mS duration at switch on and whenever a 5v supply failure occurs. In addition to the reset provided by IC6, the microprocessor has a built in watchdog timer which will create a reset if a software crash occurs for any reason.

Non-Volatile Memory (NVM). Integrated Circuit IC3 provides 1Kbit of E² memory for the retention of important data after power down.

Fluxgate (Compass). Two anti-phase signals are provided from microprocessor Ports P1.7 and P1.6. These signals are buffered by TR15 and TR16 to provide a higher current drive to the excitation coil of the fluxgate. A reference voltage level of +2 volts is provided by R46 and R53 decoupled by C53. The 2 coils, mounted at right angles, provide output signals proportional to the sine and cosine of the Earth's magnetic field. These signals are fed via the electronic switch IC9, to 2 dual slope integrating analogue to digital converters IC7 and IC 8 plus associated components. The outputs of the comparator IC7 are fed to the microprocessor Ports P1.4 and P1.5 which provide input capture facilities. Accurate timing of the conversion is kept by the microprocessor to provide simultaneous precision analogue to digital conversion of both sine and cosine signals to avoid errors created by multiplexing the inputs.

Motor Drive. The motor drive signals (MDRIVE_A and MDRIVE_B) are generated from the microprocessor at Ports P0.7 and P0.6, these lines being LOW when there is no drive and HIGH to drive. The drive outputs control IC10 and IC11 which are comparators set at threshold levels of +4V and +1V produced by the resistor network R71, R72 and R73. The comparators invert the signals and provide the current to switch the MOSFETs in stages which prevents both P and N channel MOSFETs on the same side of the "H-bridge" configuration, (i.e. TR10 and TR11 or TR12 and TR13), being partially switched on at the same time. When there is no drive, both N-channel MOSFETs TR11 and TR13 are switched on giving a direct short across the motor to the 0V line thus providing active braking

Feedback. Mechanical movement is sensed by 2 Hall Effect devices mounted on the Hall Effect PCB (Drawing [E03182](#) refers). The devices are triggered by rotating magnets mounted in the pulleywheel of the Tillerpilot drive assembly to produce quadrature style feedback. The 2 feedback signals, FB1 and FB2 which are at logic levels, are connected to microprocessor ports P1.1 and P1.2.

EMC. Capacitors with values of 100pF, 100nF and 1nF are extensively used to decouple noise from switched data lines. Two A.C. coupled connections labelled "CHASSIS" , routed via capacitors C63 and C64, were provided for interconnection to the internal metalwork for EMC purposes. Tests have confirmed that connection is not required.

5.3 Hall Effect PCB.

Introduction. The Hall Effect PCB is a generic item which can be used for both Tillerpilots TP10, TP20 and TP30 and Wheelpilots WP10 and WP30. For Tillerpilots, the Hall Effect devices are mounted vertically into the PCB and horizontally for Wheelpilots. The circuit diagram for the Hall Effect PCB is given in Drawing No. **E03182**.

Feedback. Two Hall Effect sensors HE1 and HE2 are mounted on the Hall Effect PCB and sense the rotation of 2 small bar magnets mounted 1800 apart in the pulley wheel. This produces a quadrature feedback output, at logic levels, FB1 and FB2. The PCB is powered from the host unit +5V regulated supply, the line being filtered by C1, and signals FB1 and FB2 are fed back to the microprocessor via pull-up resistors on the host unit PCB.



SIMRAD

A KONGSBERG Company

TP10, TP20 & TP30 Tillerpilot Circuit Diagrams

6 CIRCUIT DIAGRAMS

6.1 Circuit Schematics

TP10 / WP10 PCB Circuit Diagram	E03371
TP20 / 30 & WP30 PCB Circuit Diagram	E03372
Hall Effect PCB Circuit Diagram	E03182

6.2 Component Lists and Layouts

TP10 PCB Assembly Detail	E03181
TP20 / TP30 PCB Assembly Detail	E03178
Hall Effect PCB Assembly Detail	E03184

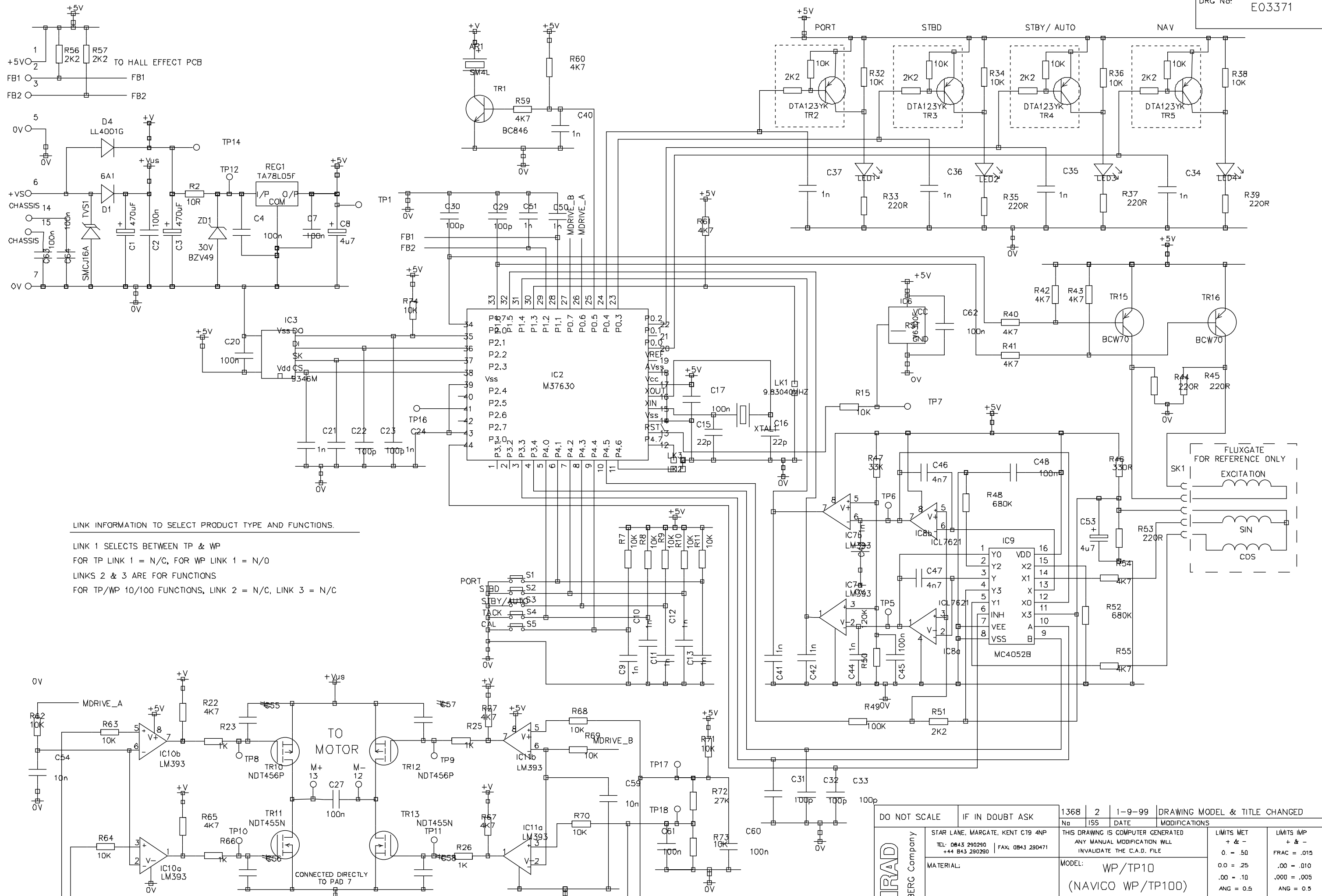

LINK INFORMATION TO SELECT PRODUCT TYPE AND FUNCTIONS.
 LINK 1 SELECTS BETWEEN TP & WP
 FOR TP LINK 1 = N/C, FOR WP LINK 1 = N/0
 LINKS 2 & 3 ARE FOR FUNCTIONS
 FOR TP/WP 10/100 FUNCTIONS, LINK 2 = N/C, LINK 3 = N/C

NOTE: - # PROVISION MADE FOR FITTING CAPACITORS FOR EM EMISSIONS

DO NOT SCALE		IF IN DOUBT ASK		1368	2	1-9-99	DRAWING MODEL & TITLE CHANGED	
STAR LANE, MARGATE, KENT CT9 4NP		THIS DRAWING IS COMPUTER GENERATED		LIMITS MET		LIMITS IMP		
TEL: 0843 290290		ANY MANUAL MODIFICATION WILL		0. = .50		FRAC = .015		
FAX: 0843 290290		INVALIDATE THE C.A.D. FILE		0.0 = .25		.00 = .010		
MATERIAL:		MODEL: WP/TP10		.00 = .10		.000 = .005		
DATE:		(NAVICO WP/TP100)		ANG = 0.5		ANG = 0.5		
SCALE:		TITLE: PCB CIRCUIT DIAGRAM		DRG No: E03371		ISSUE: 2		
DRAWN BY: R.F.		CHECKED:		APPROVED:				
DATE: 12-5-98		DATE:		DATE:				



LINK INFORMATION TO SELECT PRODUCT TYPE AND FUNCTIONS.

LINK 1 SELECTS BETWEEN TP & WP
 FOR TP LINK 1 = N/C, FOR WP LINK 1 = N/O
 LINKS 2 & 3 ARE FOR FUNCTIONS
 FOR TP/WP 20/200CX, LINK 2 = N/C, LINK 3 = N/O
 FOR TP/WP 30/300CX, LINK 2 = N/O, LINK 3 = N/O

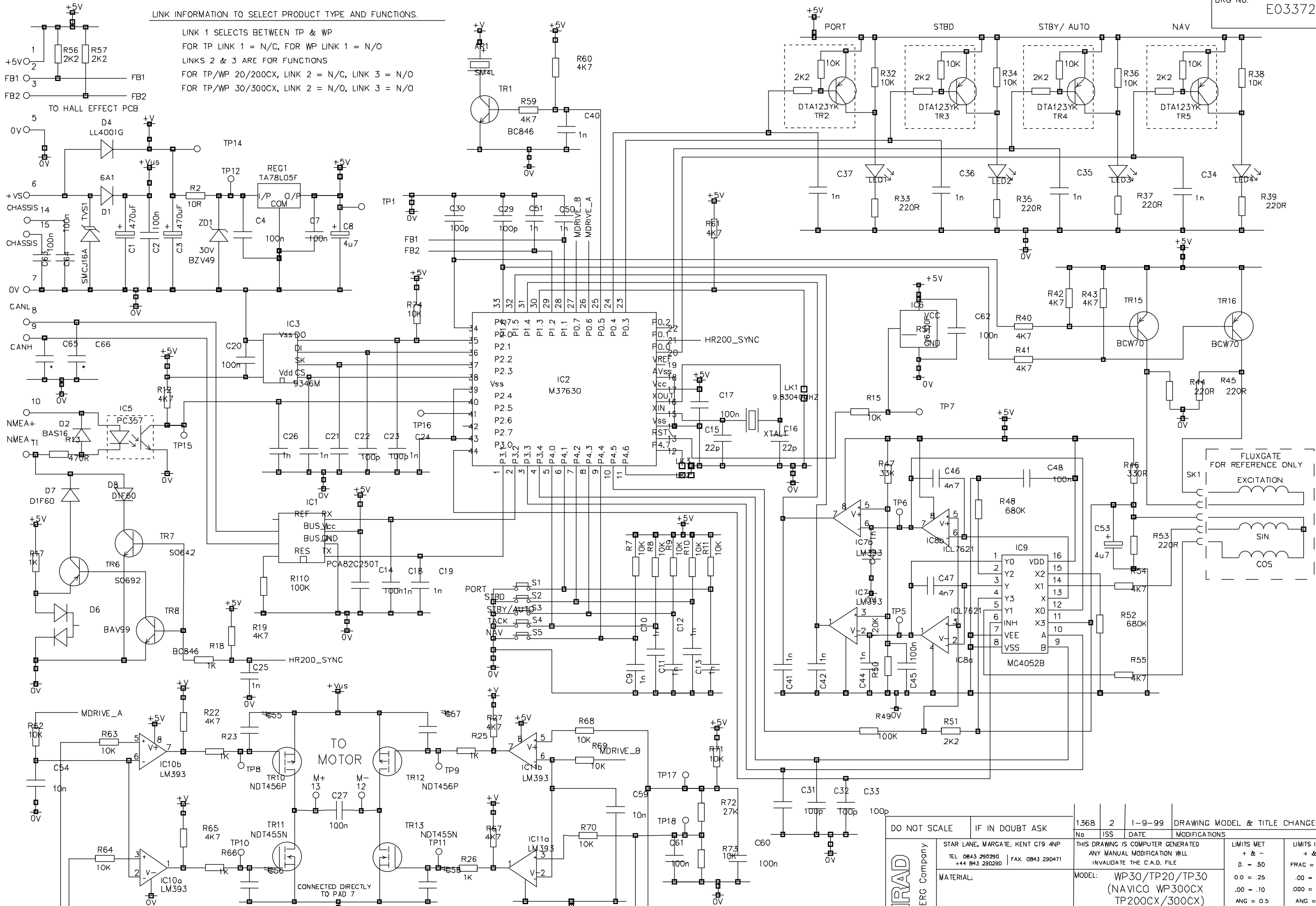

NOTE: - # PROVISION MADE FOR FITTING CAPACITORS FOR EM EMISSIONS

DO NOT SCALE		IF IN DOUBT ASK		136B	2	1-9-99	DRAWING MODEL & TITLE CHANGED		
STAR LANE, MARGATE, KENT CT9 4NP		TEL 0843 290290		THIS DRAWING IS COMPUTER GENERATED		LIMITS MET		LIMITS IMP	
TEL 0843 290290		FAX 0843 290471		ANY MANUAL MODIFICATION WILL		D. = .50		FRAC = .015	
MATERIAL:		MODEL: WP30/TP20/TP30		INVALIDATE THE C.A.D. FILE		0.0 = .25		.00 = .010	
		(NAVICO WP300CX				.00 = .10		.000 = .005	
		TP200CX/300CX)				ANG = 0.5		ANG = 0.5	
DATE:	SCALE:	TITLE:		DRG No:		ISSUE:			
1-9-99		PCB CIRCUIT DIAGRAM		E03372		2			

DRAWN BY: R.F.
 CHECKED: DATE:
 APPROVED: DATE:



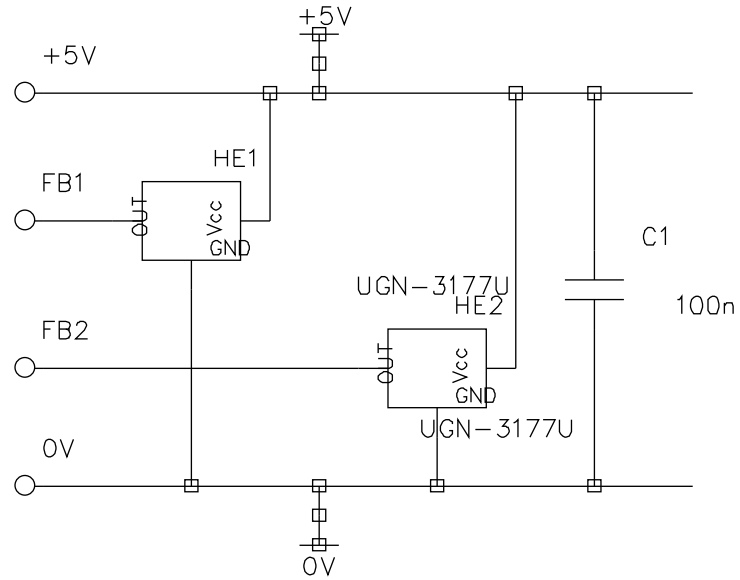

DRAWN BY: R.F.	CHECKED:	APPROVED:
DATE: 30-9-97	DATE:	DATE:

DO NOT SCALE		IF IN DOUBT ASK		1368	2	1-9-99	DRAWING MODEL & TITLE CHANGED		
				No	ISS	DATE	MODIFICATIONS		
SIMRAD A KONGSBERG Company	STAR LANE, MARGATE, KENT CT9 4NP TEL: 0843 290280 FAX: 0843 290471			THIS DRAWING IS COMPUTER GENERATED ANY MANUAL MODIFICATION WILL INVALIDATE THE C.A.D. FILE			LIMITS MET	LIMITS IMP	
	MATERIAL:			MODEL: WP/TP10/30 (NAVICO WP/TP300/100)			+ & - 0. = .50	+ & - FRAC = .015	
	DATE:			SCALE:			0.0 = .25	.00 = .010	
	1-9-99						.00 = .10	.000 = .005	
			TITLE:			ANG = 0.5		ANG = 0.5	
			1-9-99			HALL EFFECT PCB CIRCUIT DIAGRAM		DRG No: E03182	ISSUE: 2

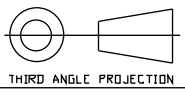

SURFACE MOUNT COMPONENTS

ITEM	QTY	PART No	COMP REF	DESCRIPTION
1	1	E03370	-	PCB DRILLED
2	1	100125	R2	1206 10R
3	4	100128	R23,R25,R26,R66	1206 1K
4	3	100129	R51,R56,R57	1206 2K2
5	13	100131	R22,R27,R40,R41,R42,R43,R54 R59,R60,R61,R65,R67	1206 4K7
6	19	100132	R7,R8,R9,R10,R11,R15,R32,R34 R36,R38 ,R62,R63,R64,R68,R69 R71,R73 ,R74	1206 10K
7	7	100133	R33,R35,R37,R39,R44,R45,R53	1206 220R
8	1	100136	R50	1206 120K
9	1	100140	R49	1206 100K
10	1	100141	R46	1206 330R
11	2	100142	R48,R52	1206 680K
12	1	100216	R47	1206 33K
13	1	100219	R72	1206 27K
14	1	110104	C53	4u7 SM ELECT
15	2	110109	C46,C47	1210 4n7
16	18	110115	C9,C10,C11,C12,C13,C21 ,C24,C34 C35,C36,C37,C40,C41,C42,C43 ,C44 C50,C51	0805 1n
17	2	110116	C15,C16	0805 22p
18	7	110118	C22,C23,C29,C30,C31,C32,C33	0805 100p
19	13	110128	C2,C4,C7,C17,C20,C27,C45,C48 C61 ,C62,C63,C64	0805 100n
20	2	110138	C54,C59	0805 10n
21	1	110169	C8	4u7 SM ELECT
22	1	120038	ZD1	BZV49 30V
23	1	120040	D4	LL4001G
24	1	120079	TVS1	SMCJ16A
25	2	130055	TR11,TR13	NDT455N
26	2	130056	TR10,TR12	NDT456P
27	1	130028	TR1	BC846
28	2	130029	TR15,TR16	BCW70
29	4	130053	TR2,TR3,TR4,TR5	DTA123YK
30	1	140068	IC8	7621
31	3	140069	IC7 ,IC10,IC11	LM393
32	1	140070	IC9	MC4052B
33	1	140077	IC3	NMC9346
34	1	140092	REG1	TA78L05F
35	1	140147	IC6	V6300F
36	1	160066	XTAL1	9.83040MHZ
37	5	210019	S1,S2,S3,S4,S5	SM_SWITCH
38	1	E03398	IC2	PROG'D MICRO UNPROGRAMMED PART No IS 140163

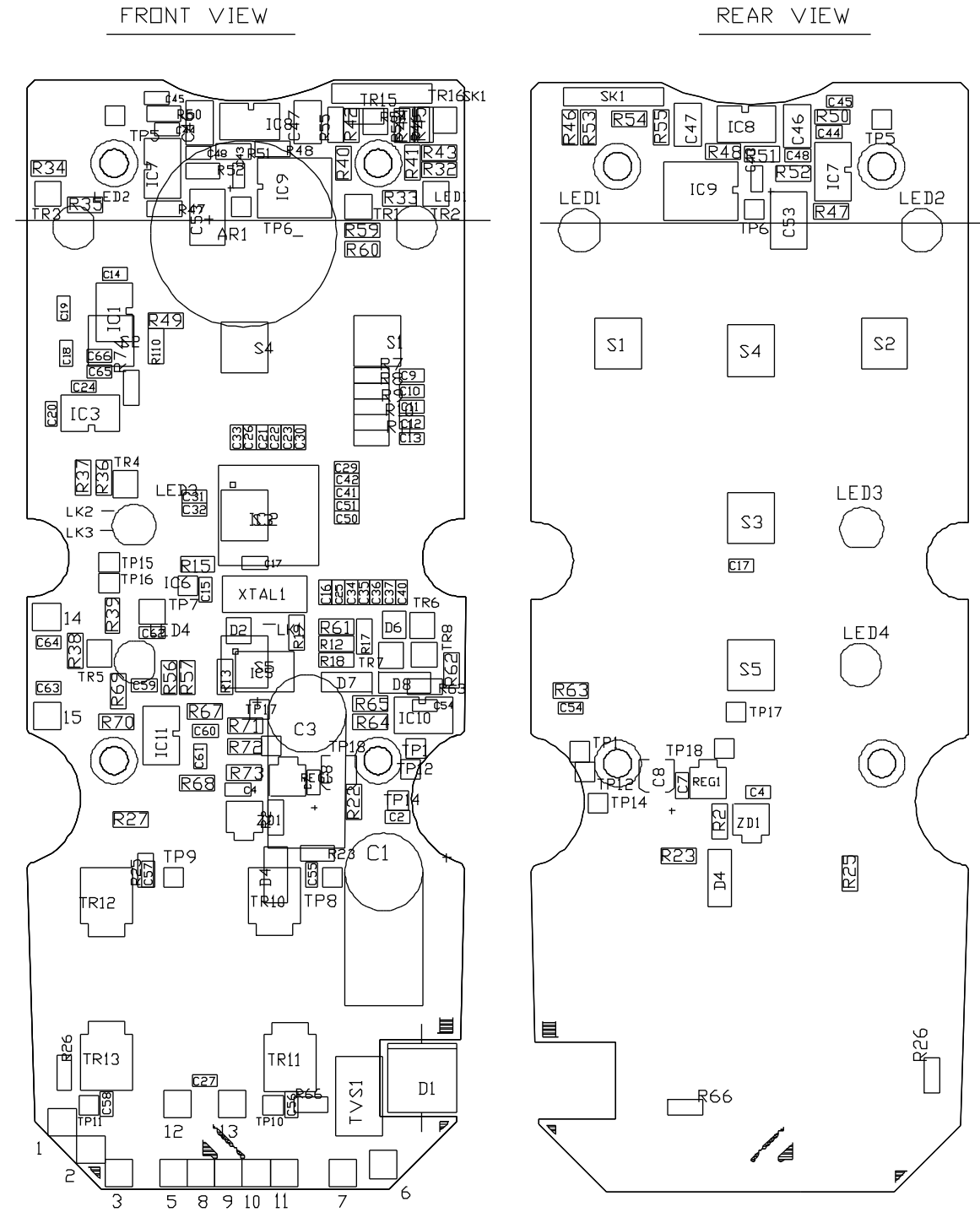

LINK INFORMATION TO SELECT PRODUCT TYPE AND FUNCTIONS.
 LINK 1 SELECTS BETWEEN TP & WP
 FOR TP LINK 1 = N/C, FOR WP LINK 1 = N/D
 LINKS 2 & 3 ARE FOR FUNCTIONS
 FOR TP/WP 10/100 FUNCTIONS, LINK 2 = N/C, LINK 3 = N/C

CONVENTIONAL MOUNT COMPONENTS

39	2	110110	C1,C3	470UF 25V ELECT
40	3	120010	LED1,LED3,LED4	L-53EC RED LED
41	1	120011	LED2	EBG5504S LED GREEN
42	1	120041	D1	6A1
43	1	160028	AR1	SM4L
44	0.25	170078	SK1	SKT STRIP 20 WAY

* C55,C56,C57,C58 NOT FITTED
 C65,C66 REFER TO CIRCUIT DIAGRAM E03371 FOR INTENDED PURPOSE.

	DO NOT SCALE	IF IN DOUBT ASK	1368 4 1-9-99	DRAWING MODEL & TITLE CHANGED
	STAR LANE, MARGATE, KENT CT9 4NP		1203 3 12-5-98	SEE MOD No. 1203
	TEL: 0843 290290 FAX: 0843 290471		1100 2 6-11-97	C25,26 REMOVED,C62,C63,C64 ADDED
	MATERIAL:		MODIFICATIONS	
DATE: 1-9-99		SCALE: N.T.S	THIS DRAWING IS COMPUTER GENERATED ANY MANUAL MODIFICATION WILL INVALIDATE THE C.A.D. FILE	
TITLE: PCB ASSEMBLY DETAIL		MODEL: WP/TP10 (NAVICD WP/TP100)		LIMITS MET + & - 0. = .50 0.0 = .25 .00 = .10 ANG = 0.5
DRAWN BY: R.F.		CHECKED:	APPROVED:	DRG No: E03181
DATE: 12-5-98		DATE:	DATE:	ISSUE: 4



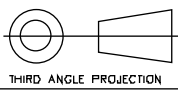

SURFACE MOUNT COMPONENTS

FRONT VIEW

REAR VIEW

DRG No: E03178

ITEM	QTY	PART No	COMP REF	DESCRIPTION
1	1	E03370	-	PCB DRILLED
2	1	100124	R13	1206 470R
3	1	100125	R2	1206 10R
4	6	100128	R17,R18 ,R23,R25,R26 ,R66	1206 1K
5	3	100129	R51,R56,R57	1206 2K2
6	15	100131	R12,R19,R22,R27,R40,R41 ,R42,R43 R54,R55,R59,R60,R61 ,R65,R67	1206 4K7
7	19	100132	R7,R8,R9,R10,R11,R15,R32,R34,R36 R38 ,R62,R63,R64,R68,R69 ,R70 ,R71 R73,R74	1206 10K
8	7	100133	R33,R35,R37,R39,R44,R45,R53	1206 220R
9	1	100136	R50	1206 120K
10	2	100140	R49,R110	1206 100K
11	1	100141	R46	1206 330R
12	2	100142	R48,R52	1206 680K
13	1	100216	R47	1206 33K
14	1	100219	R72	1206 27K
15	1	110104	C53	4u7 SM ELECT
16	2	110109	C46,C47	1210 4n7
17	20	110115	C9,C10,C11,C12,C13,C18,C19,C21 C24,C25,C26,C34,C35,C36,C37 C40,C41,C42,C50,C51	0805 1n
18	2	110116	C15,C16	0805 22p
19	7	110118	C22,C23,C29,C30,C31,C32,C33	0805 100p
20	2	110124	C43,C44	0805 150p
21	14	110128	C2,C4,C7,C14,C17,C20,C27,C45,C48 C60,C61,C62,C63,C64	0805 100n
22	2	110138	C54,C59	0805 10n
23	1	110169	C8	4u7 SM ELECT
24	1	120036	D2	BAS16T
25	1	120038	ZD1	BZV49 30V
26	1	120040	D4	LL4001G
27	1	120043	D6	BAV99
28	2	120070	D7,D8	D1F60
29	1	120079	TVS1	SMCJ16A
30	2	130055	TR11,TR13	NDT455N
31	2	130056	TR10,TR12	NDT456P
32	2	130028	TR1 ,TR8	BC846
33	2	130029	TR15,TR16	BCW70
34	1	130049	TR6	SO692
35	1	130050	TR7	SO642
36	4	130053	TR2,TR3,TR4,TR5	DTA123YK
37	1	140068	IC8	7621
38	3	140069	IC7 ,IC10,IC11	LM393
39	1	140070	IC9	MC4052B
40	1	140075	IC5	PC357
41	1	140077	IC3	NMC9346
42	1	140092	REC1	TA78L05F
43	1	140096	IC1	PCA82C250T
44	1	140147	IC6	V6300F
45	1	160066	XTAL1	9.83040MHZ
46	5	210019	S1,S2,S3,S4,S5	SM_SWITCH
47	1	E03398	IC2	PROG'D MICRO UNPROGRAMMED PART No. IS 140163

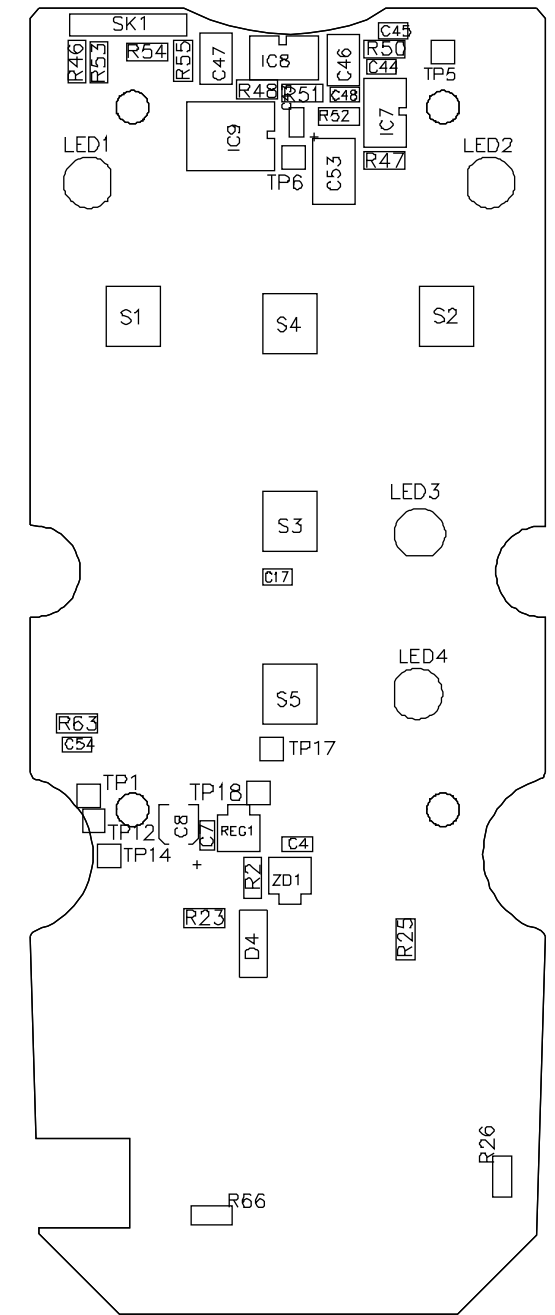
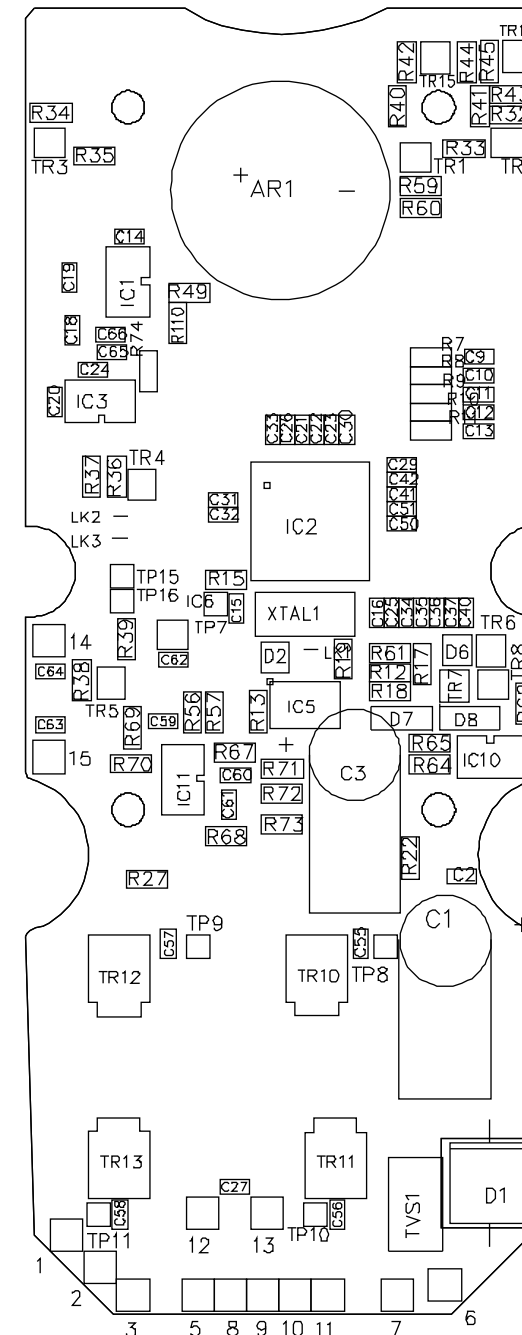

LINK INFORMATION TO SELECT PRODUCT TYPE AND FUNCTIONS.

LINK 1 SELECTS BETWEEN TP & WP
FOR TP LINK 1 = N/C, FOR WP LINK 1 = N/O
LINKS 2 & 3 ARE FOR FUNCTIONS
FOR TP/WP 20/200CX, LINK 2 = N/C, LINK 3 = N/O
FOR TP/WP 30/300CX, LINK 2 = N/O, LINK 3 = N/O

CONVENTIONAL MOUNT COMPONENTS

48	2	110110	C1,C3	470UF 25V ELECT
49	3	120010	LED1,LED3,LED4	L-53EC LED RED
50	1	120011	LED2	EBG5504S LED GREEN
51	1	120041	D1	6A1
52	1	160028	AR1	SM4L
53	0.25	170078	SK1	STRIP 20 WAY

C55,C56,C57,C58 NOT FITTED
C65,C66 REFER TO CIRCUIT DIAGRAM
E03372 FOR INTENDED PURPOSE.

DRAWN BY: R.F.	CHECKED:	APPROVED:
DATE: 30-3-98	DATE:	DATE:

DO NOT SCALE		IF IN DOUBT ASK	
STAR LANE, MARGATE, KENT CT9 4NP		THIS DRAWING IS COMPUTER GENERATED	
TEL 0843 290280		ANY MANUAL MODIFICATION WILL	
FAX 0843 290290		INVALIDATE THE C.A.D. FILE	
MATERIAL:		MODEL: WP30/TP20/TP30	
DATE: 7-1-00		(NAVICO WP300CX)	
SCALE:		(TP200CX/300CX)	
TITLE: PCB ASSEMBLY		LIMITS MET	
DETAIL		+ & -	
DRG No: E03178		0. = .50	
ISSUE: 4		.00 = .010	
		.00 = .005	
		ANG = 0.5	
		ANG = 0.5	



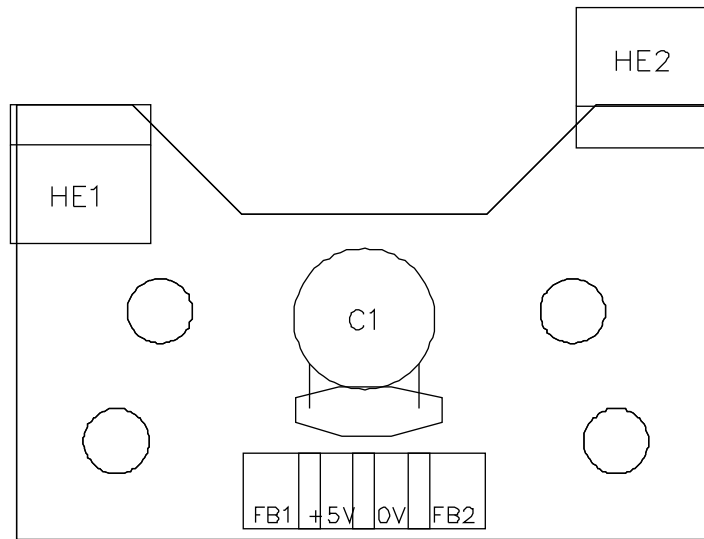

CONVENTIONAL MOUNT COMPONENTS

ITEM	QTY	PART No	COMP REF	DESCRIPTION
1	1	E03183	-	PCB DRILLED
2	1	110001	C1	100n CERAMIC DISC
3	2	140010	HE1,HE2	UGN3177U

NOTE: - PART No. E03184: TP. HE1,HE2 MOUNTED VERTICALLY.
 PART NO. E03184: WP. HE1,HE2 MOUNTED HORIZONTALLY.

1368	2	1-9-99	: TP,; WP DIFFERENCE NOTES ADDED DRAWING MODEL & TITLE CHANGED
No	ISS	DATE	MODIFICATIONS
 SIMRAD A KONGSBERG Company	STAR LANE, MARGATE, KENT CT9 4NP TEL 0843 290290 TELEX 965093 NAVICO G ++4 843 290290 FAX: 0843 290471		THIS DRAWING IS COMPUTER GENERATED ANY MANUAL MODIFICATION WILL INVALIDATE THE C.A.D. FILE
	MATERIAL:		MODEL: WP/TP10/30 (NAVICO WP/TP300/100)
DATE:	SCALE:	TITLE:	DRG No:
1-9-99		HALL EFFECT PCB ASSEMBLY DETAIL	E03184
APPROVED:			ISSUE:
			2

DRAWN BY:	CHECKED:	APPROVED:
R.F.		
DATE: 30-9-97	DATE:	DATE:





SIMRAD

A KONGSBERG Company

TP10, TP20 & TP30 Tillerpilot Programming & Configuration

7 PROGRAMMING AND CONFIGURATION

For further details of normal operation please refer to the appropriate user manual - [TP10](#) or [TP20/TP30](#).

3 Configuration

3.1 Porthand Mounting

Although the Tillerpilot is factory preset for Starboard side mounting, it is possible to reconfigure it for mounting on the Port side of the cockpit, to facilitate easy installation on most types of yacht.

With the power off, hold down the **CAL** and **TACK** keys and switch on the power. Either the Port or Starboard LED will illuminate, depending on the current mounting configuration. Press the **PORT** key to select Port side mounting. The Port LED only will remain illuminated to indicate selection. Confirm selection and exit to Standby Mode by pressing **CAL**. (Fig 3.2).

To select Starboard mounting, repeat the above procedure, but press the **Starboard** key instead of **Port**.

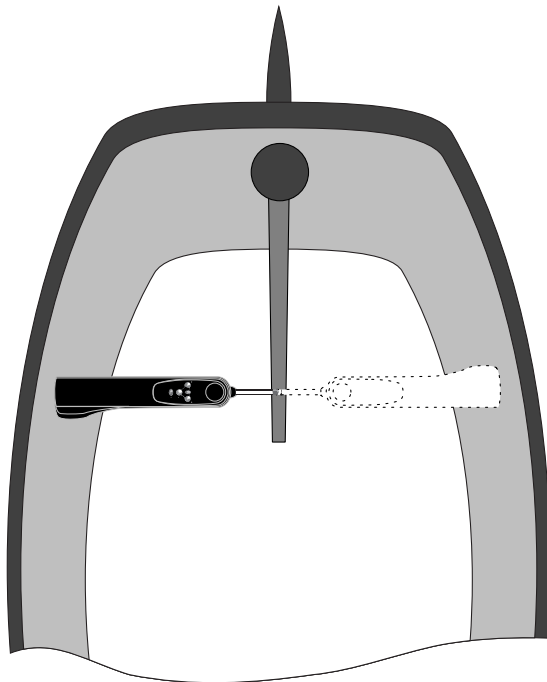

Fig 3.1 - Starboard and Port mounting options

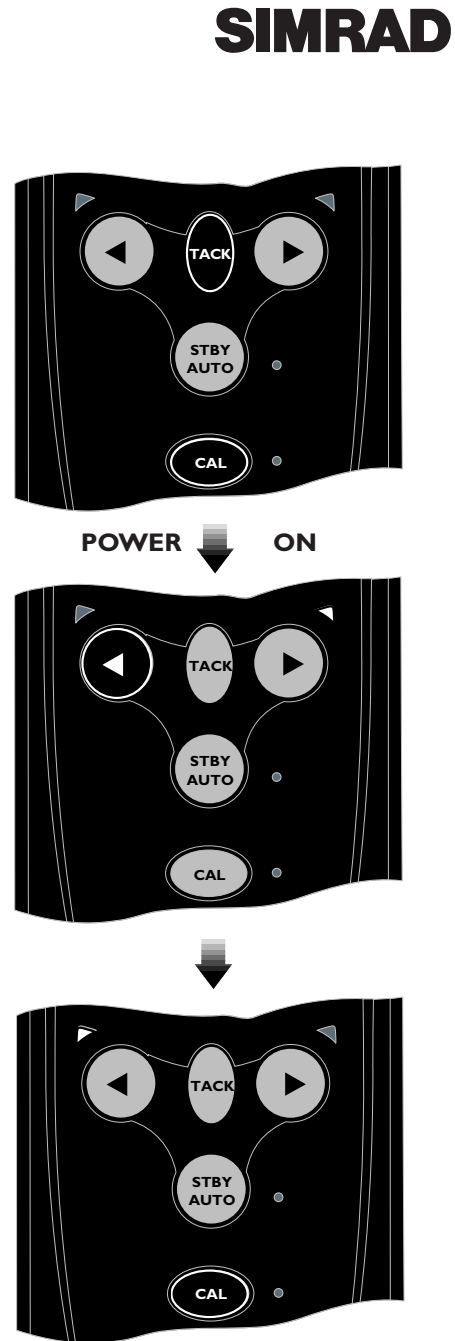

Fig 3.2 - Configuring for Port mounting



SIMRAD

A KONGSBERG Company

TP10, TP20 & TP30 Tillerpilot Fault Finding

8 FAULT FINDING

8.1 Common User Faults.

Excerpt from [TP10](#) manual -

5.3 Fault Finding		
Symptom	Probable Cause	Remedy
When engaged, the pilot immediately applies a large helm angle and increases course error.	* Tillerpilot is configured for Porthand setting but installed on Starboard side (or vice versa).	* Refer to section 3.1.
After functioning normally course is suddenly lost and the Tillerpilot goes into Standby Mode.	* Power interrupted briefly, or low voltage. * Cable from battery to socket too small. * Intermittent connection.	* Increase size of cable. * Check all connections. * Charge batteries. * Uprate batteries.
Helm is hard over and alarm is continuously on.	* Steerage way insufficient to control course, or sails are aback. Pulsing is a correct safety feature when tiller is at full travel.	* Reset the vessel on course and re-engage pilot.
Power supply is live, but pilot is not on.	* Pilot is wired incorrectly.	* Check wiring of pilot (see section 4.2).

Page 15

Common User Faults ctdExcerpt from [TP20/TP30](#) manual -**6.2 Fault Finding**

Symptom	Probable Cause	Remedy
When engaged, the pilot immediately applies a large helm angle and increases course error.	Tillerpilot is configured for Porthand setting but installed on Starboard side (or vice versa).	* Refer to section 4.1.
After functioning normally course is suddenly lost and the Tillerpilot goes into Standby Mode.	* Power interrupted briefly, or low voltage. * Cable used to socket too small. * Intermittent connection.	* Increase size of cable. * Check all connections. * Charge batteries. * Uprate batteries.
Helm is hard over and alarm is continuously on.	* Steerage way insufficient to control course, or sails are aback. Pulsing is a correct safety feature when tiller is at full travel.	* Reset the vessel on course and re-engage pilot
Power socket is live, but pilot is not on.	* Socket is wired incorrectly.	* Check wiring of socket (see section 5.2).
Loss of course under Sail To Wind Mode.	* Apparent wind has become too light to give a consistent direction.	* Change to Compass Mode.
Cannot select Sail To Wind Mode.	* Masthead unit is not connected. * Corus system is not switched on. * Required NMEA sentence not being transmitted.	* Fit ATM601 Masthead Unit. * Check Corus Monocable connections. * See section 5.5.
Cannot select NavLock Mode.	* Navigational receiver not connected. * No waypoints have been programmed. * Wrong NMEA format is being used.	* Check NMEA interface connections. * Check NMEA0183 format is being transmitted by navigational receiver.
Autotack function not working.	* Pilot is in NavLock Mode. * Pilot is in Steer To Wind Mode and a) apparent wind is >90° b) autotack being attempted is in the wrong direction.	* Exit NavLock. * Luff up until apparent wind is less than 90°.
Pilot exits NavLock before waypoint is reached.	* Cross Track Error has exceeded 1.21 Nm.	* Reset the vessel on course and re-engage NavLock.

8.2 Common Technical Faults.

None yet identified.



SIMRAD

A KONGSBERG Company

**TP10, TP20 & TP30 Tillerpilot
Spares Packs**

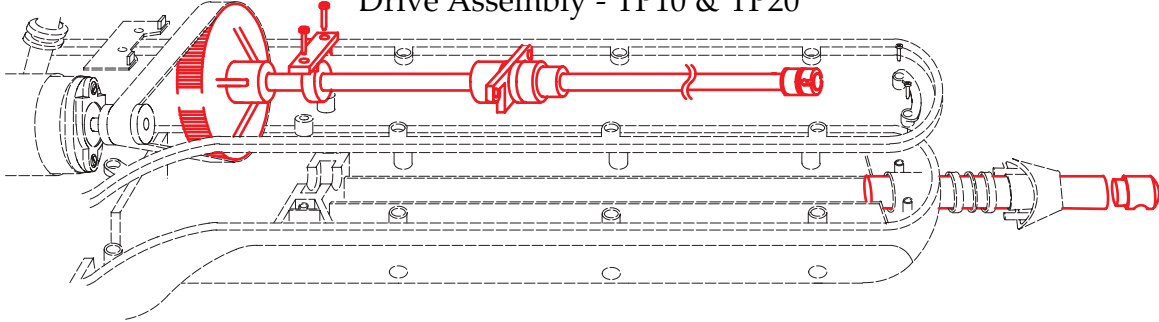
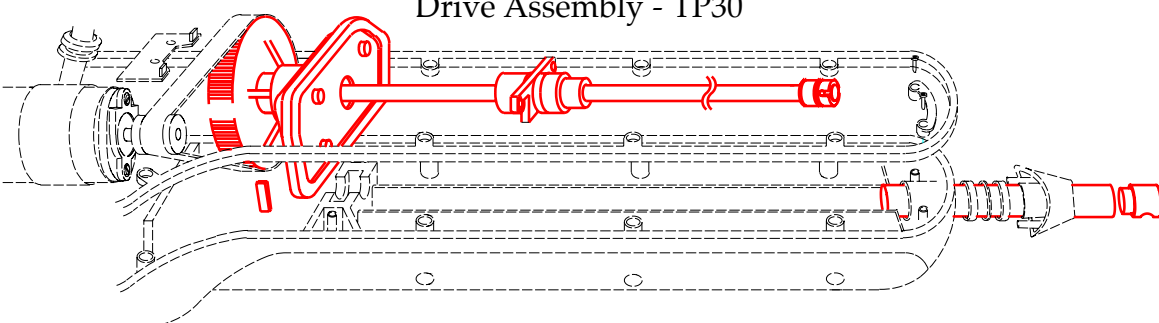
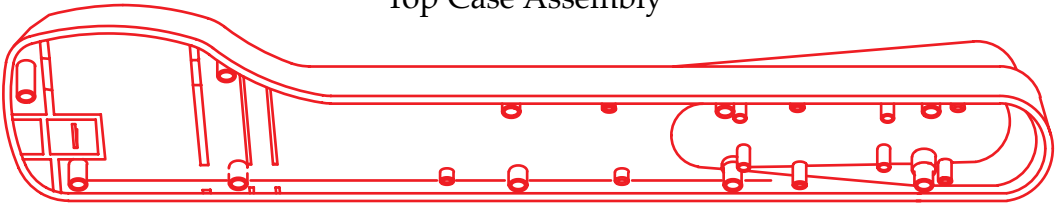
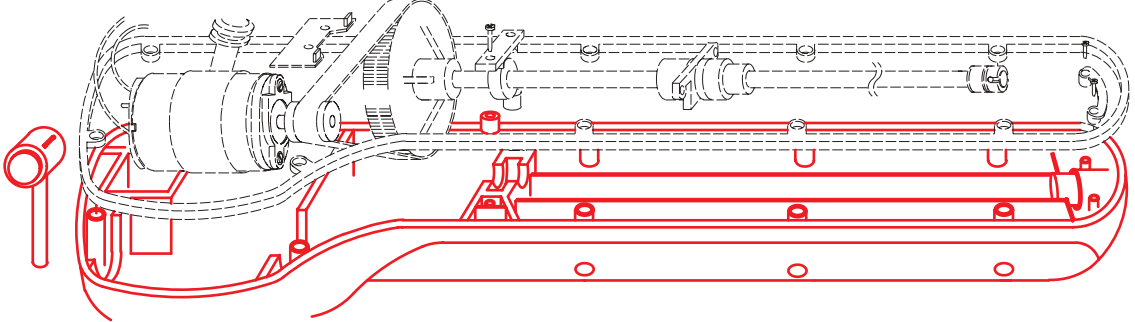
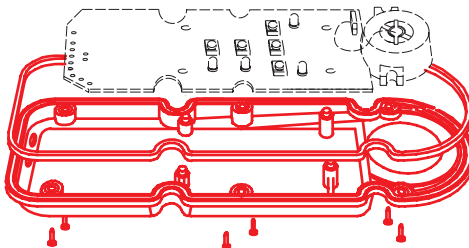

Simrad Navico Spares Packs **SIMRAD**

Product - Tillerpilots TP10, TP20, TP30

Part No.	Description
<p>TPPK1</p>	<p>Drive Assembly - TP10 & TP20</p> 
<p>TPPK22</p>	<p>Drive Assembly - TP30</p> 
<p>TP10 - TPPK2</p> <p>TP20 - TPPK16</p> <p>TP30 - TPPK20</p>	<p>Top Case Assembly</p> 
<p>TP10 - TPPK25</p> <p>TP20 & TP30 - TPPK3</p>	<p>Bottom Case Assembly, Cable Loom & Pivot Pin</p> 
<p>TP10 - TPPK4</p> <p>TP20 & TP30 - TPPK17</p>	<p>PCB Cover & Seal</p> 

Simrad Navico Spares Packs **SIMRAD**

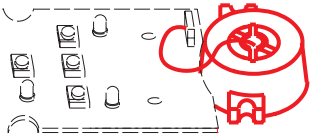
Product - Tillerpilots TP10, TP20, TP30

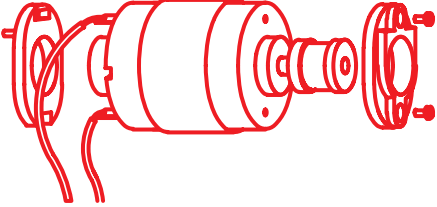
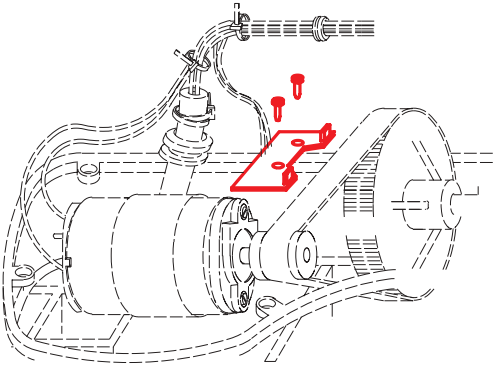
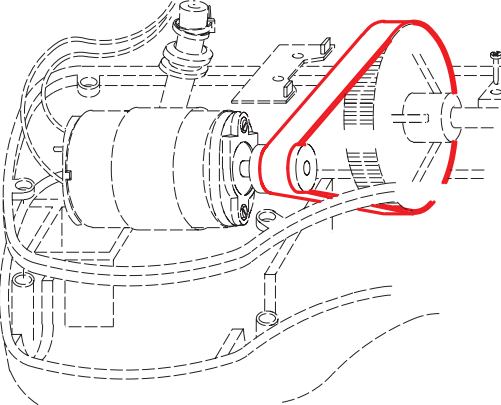
Part No.	Description
TPPK6	<p style="text-align: center;">Fluxgate Assembly</p> 
TPPK7	<p style="text-align: center;">Mounting Pin, Cup & Connector</p> 
TPPK8	<p style="text-align: center;">Motor Assembly</p> 
TPPK9	<p style="text-align: center;">Feedback Kit</p> 
TPPK10	<p style="text-align: center;">Drive Belt</p> 

Simrad Navico Spares Packs **SIMRAD**

Product - Tillerpilots TP10, TP20, TP30

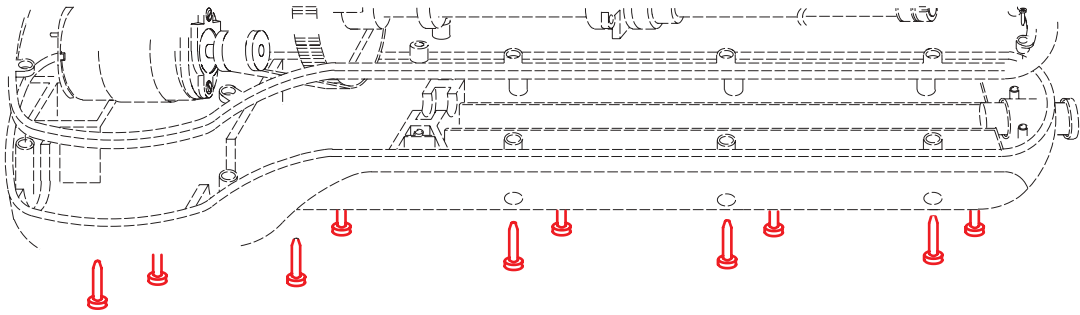
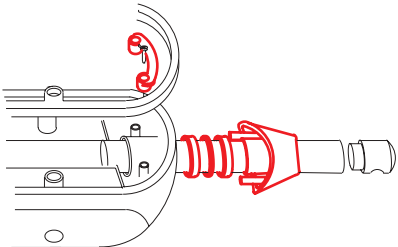
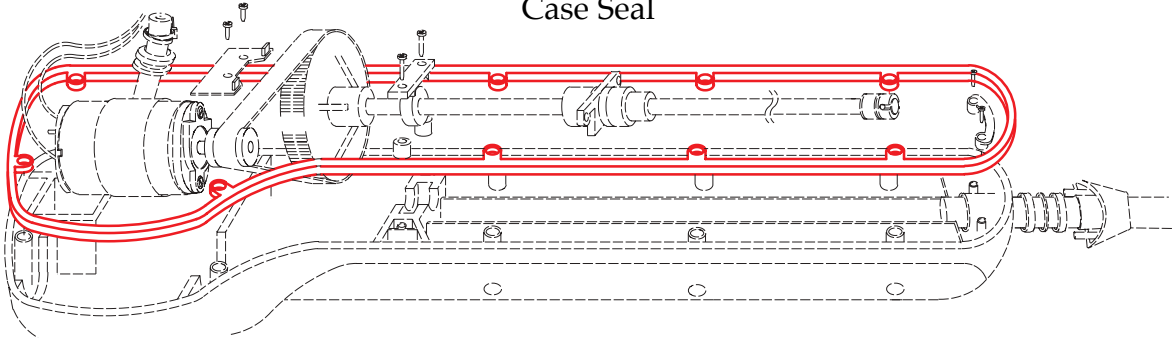
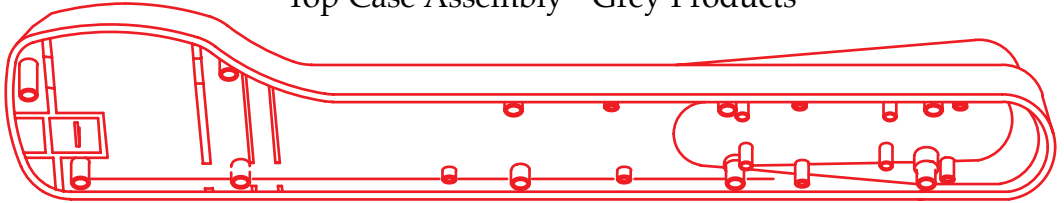
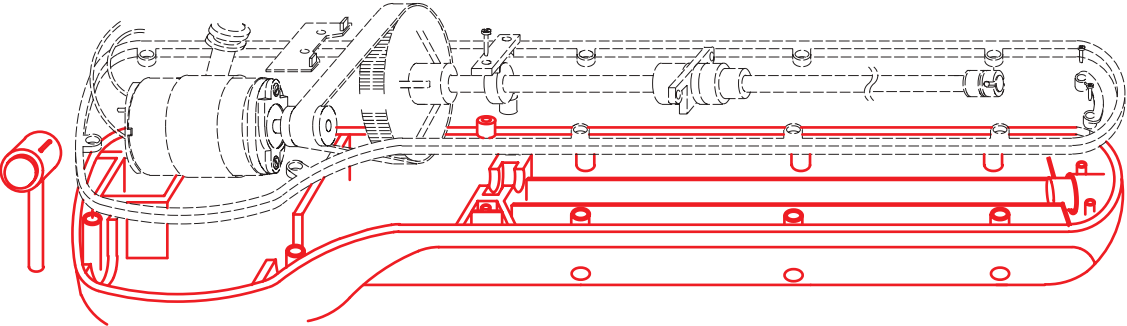
Part No.	Description
TPPK11	<p>Case Screws</p> 
TPPK12	<p>End Cap, Retainer & Seals</p> 
TPPK13	<p>Case Seal</p> 
TP100 - TPPK14 TP200CX - TPPK24 TP300CX - TPPK23	<p>Top Case Assembly - Grey Products</p> 
TPPK15	<p>Bottom Case Assembly & Pivot Pin - Grey Products</p> 

Simrad Navico Spares List **SIMRAD**

Product - Tillerpilots TP10, TP20, TP30

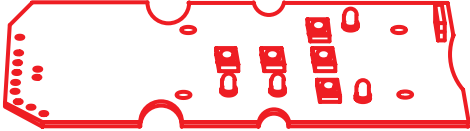
Part No.	Description
See below	<p style="text-align: center;">PCB Assembly</p> 

Tillerpilot PCB Assembly Variants

The Tillerpilot PCB assembly variants can be divided into 3 groups -

1. Feedback produced from the motor back emf
2. Feedback produced from a Hall Effect sensor PCB assembly
3. Introduction of Surface Mount microprocessor

Pilot Version	TP100 Back emf	TP200CX Back emf	TP300C Back emf	TP300CX Back emf	TP100 Hall Effect	TP200CX Hall Effect	TP300CX Hall Effect
PCB Assy	E02549	E02550	E02550	E02550	E03181	E03178	E03178
General Assy Drawing No.	E02587	Not Issued	E02616	E02616	E03299	E03262	E03300
Circuit Diag Drawing No.	E02549	E02550	E02550	E02550	E03179	E03176	E03176
Serial Numbers	to PE8817	to PB1483	to MI2954	MK3143- OD6414	PE8818-	PB1484-	OD6415-

Pilot Version	TP10 SMD Micro	TP20 SMD Micro	TP30 SMD Micro
PCB Assy	E03181	E03178	E03178
General Assy Drawing No.	E03504	E03505	E03506
Circuit Diag Drawing No.	E03371	E03372	E03372
Serial Numbers	OL7653-	OL1384-	OL7190-