

e lektor

Let the Internet of Things Commence



● **ATmega on the Internet** | High-End Amp for Active Speakers

2-amp MPP Tracking Charger | UART Module for ECC | Mini Modules for Breadboarding

DDS RF Signal Generator | AC-AC & AC-DC Power Adapter Tester | **One Protocol for IoT**

● **Intel Galileo-Arduino** | PCB Transformer

● WIZnet 5500 Challenge | **HP Model 200AB Audio Oscillator**

US \$9.00 - Canada \$10.00



7 25274 24965 7

APEC[®] 2014

March 16–20, 2014

Fort Worth Convention Center

Fort Worth, TX

THE PREMIER GLOBAL EVENT IN POWER ELECTRONICS[™]

Visit the APEC 2014
web site for the latest
information!

www.apec-conf.org

SPONSORED BY



Looking to speed your analog development time?

PIC® MCUs with Intelligent Analog make designs easier

Microchip's first PIC® MCUs with 16-bit ADC and 10 Msps 12-bit ADC



With a powerful combination of rich analog integration and low power consumption, the PIC24FJ128GC010 family enables a significant cost reduction over a multi-chip design as well as enabling lower noise, faster throughput, smaller PCB size and a faster time to market.

In addition to Microchip's first 16-bit ADC and a 10 Msps 12-bit ADC, the PIC24FJ128GC010 integrates a DAC and dual op amps to simplify precision analog design. The on-chip LCD driver provides the ability to drive displays with up to 472 segments for information-rich user displays; whilst mTouch™ capacitive touch sensing adds advanced touch capabilities.

The PIC24FJ128GC010 family helps to reduce noise to deliver more consistent analog performance in a very small form factor. Simply add sensors to the low-cost starter kit for easy prototyping.

GET STARTED IN 3 EASY STEPS:

1. Begin with the low-cost PIC24F Starter Kit for Intelligent Analog (DM240015)
2. Add custom sensors to the clean analog header to create a prototype
3. Re-use and modify the demo code to speed development



PIC24F Starter Kit for Intelligent Analog
(DM240015)

For more information, go to: www.microchip.com/get/euGC010



Microcontrollers • Digital Signal Controllers • Analog • Memory • Wireless

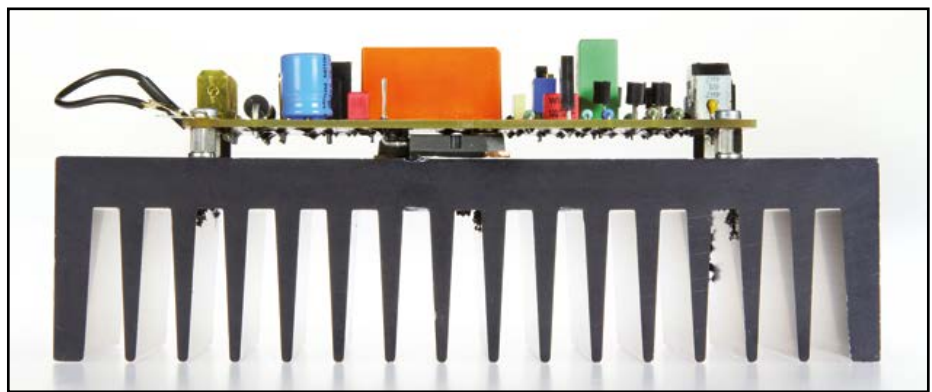
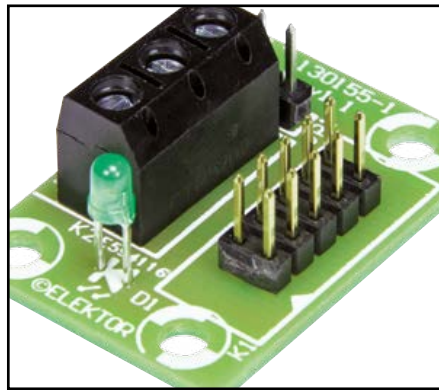

● Community

8 Connect the Magic Join the Challenge

Here are the basics to implementing the WIZ55io smart Ethernet board you get free by signing up to the Challenge jointly brought to you by Elektor, Circuit Cellar and WIZnet.

14 Elektor World

- Who's looking in your fridge?
- Don't touch—just wave
- Raspberry to the rescue
- The space-time existence of the zero-ohm resistor

● Industry

74 News & New Products

A selection of news items received from the electronics industry, labs and organizations.

● Projects

16 ATmega on the Internet (1)

A router, an RPi and some clever programming are all you need to put the ubiquitous ATmega microcontroller on the web. This month we cover the preliminaries.

22 High-End Amplifier for Active Speakers

This project underscores and proves some advantages of active filtering of loudspeaker signals.

30 2-amp Maximum Power Tracking Charger

Here we follow Anders Gustafsson again on his sailboat, this time enjoying the thought of having the batteries charged optimally through a solar panel. Anders' project is also suitable for RVs and anything else electric moving under the sun.

36 UART Module for ECC

Meet the Embedded Communica-

tion Connector, ECC. Here it's used on a module designed for RS-485 serial communication.

42 Mini Modules for Breadboarding

Don't build the same circuits like LCD, PIC MPU, LEDs, and power supply over and over again when you throw a new project on your breadboard. Be smart, follow Jennifer's modular approach.

50 DDS RF Signal Generator

A rough-n-ready, no frills way of getting the AD913 DDS chip to work for you.

Warning: Ugly Board Ahead!

56 AC-AC & AC-DC Power Adapter Tester

It's time we deal with solid testing of that ton of wall warts in our households, and possibly grab a few that make a power supply for your experiments.

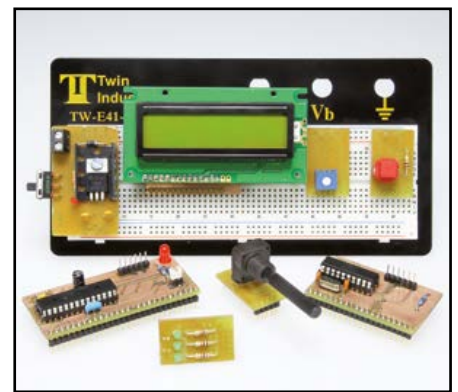
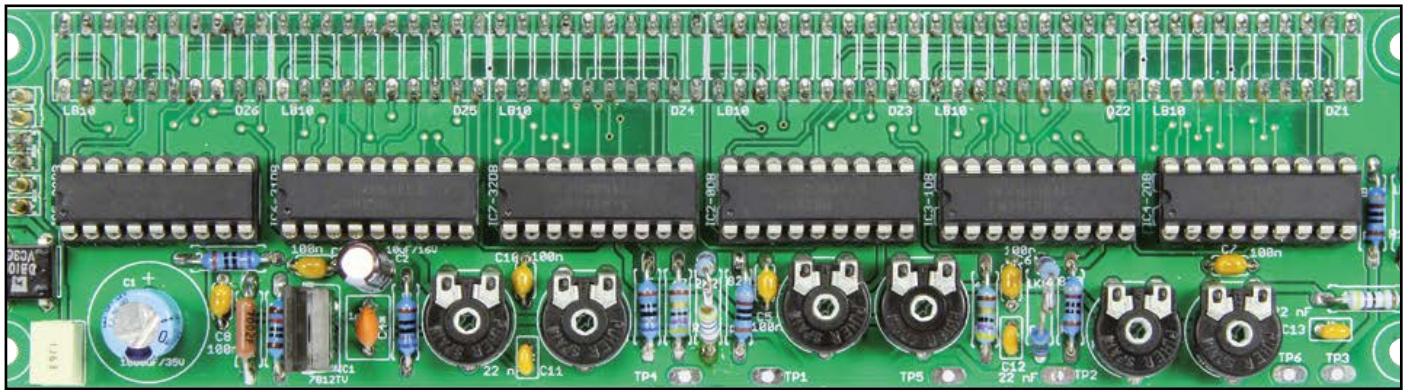

58 One Protocol for the Internet of Things

Here Elektor and Embedded Projects Journal jointly call on you to participate in a steering group of specialists aiming to develop a solid protocol for IoT.

to post-engineer a proposal for a Wattmeter project towards publication. What do you think?



Labs

64 Intel Galileo-Arduino Free Poster Download!
It seems we have to get used to Arduino boards with more muscular (and complex) processors than Atmel AVR's. Here's Intel's two cents.

66 A Tough One
Labs need advice whether or not

DesignSpark

68 DesignSpark Tips & Tricks
Day #8: Custom Board Outlines
A step by step description of shaping a board to make it fit perfectly in an enclosure—and it's not rectangular.

72 PTC Fuses
Weird Components— the series.

Regulars

- 78 Retronics**
Hewlett Packard's Model 200AB is a worthy descendant of the legendary 200A. Series Editor: Jan Buiting.
- 84 Hexadoku**
The Original Elektorized Sudoku.
- 85 Gerard's Columns: Being Accurate**
A column or two from our columnist Gerard Fonte.
- 90 Next Month in Elektor**
A sneak preview of articles on the Elektor publication schedule.

Volume 40, No. 447
March 2014

ISSN 1947-3753 (USA / Canada distribution)
ISSN 1757-0875 (UK / ROW distribution)
www.elektor.com

Elektor Magazine is published 10 times a year including double issues in January/February and July/August, concurrently by

Elektor International Media
111 Founders Plaza, Suite 300
East Hartford, CT 06108, USA
Phone: 1.860.289.0800
Fax: 1.860.461.0450

and

Elektor International Media
78 York Street
London W1H 1DP, UK
Phone: (+44) (0)20 7692 8344

Head Office:

Elektor International Media b.v.
PO Box 11
NL-6114-ZG Susteren
The Netherlands
Phone: (+31) 46 4389444
Fax: (+31) 46 4370161

USA / Canada Memberships:

Elektor USA
P.O. Box 462228
Escondido, CA 92046
Phone: 800-269-6301
E-mail: elektor@pcspublink.com
Internet: www.elektor.com/members

UK / ROW Memberships:

Please use London address
E-mail: service@elektor.com
Internet: www.elektor.com/member

USA / Canada Advertising:

Peter Wostrel
Phone: 1.978.281.7708
E-mail: peter@smmarketing.us

UK / ROW Advertising:

Johan Dijk
Phone: +31 6 15894245
E-mail: j.dijk@elektor.com

www.elektor.com/advertising

Advertising rates and terms available on request.

Copyright Notice

The circuits described in this magazine are for domestic and educational use only. All drawings, photographs, printed circuit board layouts, programmed integrated circuits, disks, CD-ROMs, DVDs, software carriers, and article texts published in our books and magazines (other than third-party advertisements) are copyright Elektor International Media b.v. and may not be reproduced or transmitted in any form or by any means, including photocopying, scanning and recording, in whole or in part without prior written permission from the Publisher. Such written permission must also be obtained before any part of this publication is stored in a retrieval system of any nature. Patent protection may exist in respect of circuits, devices, components etc. described in this magazine. The Publisher does not accept responsibility for failing to identify such patent(s) or other protection. The Publisher disclaims any responsibility for the safe and proper function of reader-assembled projects based upon or from schematics, descriptions or information published in or in relation with Elektor magazine.

© Elektor International Media b.v. 2014
Printed in the USA Printed in the Netherlands



The Thing with the Internet of Things

It's hard to not see the Internet of Things as it (IT?) grabs a firm hold of electronics and embedded technology all round. Where once the Internet was a vehicle allowing vast amounts of data, information and prattle to be exchanged between people, the trend is now towards bidirectional man-machine communication, which I am sure will be followed soon by machine-machine communication—inherently bidirectional or even closed loop—meaning the people who created the Internet and the machines are increasingly excluded from the conversation. If to you the IoT appears to be the next wave of innovation based on brand new concepts and marketable insights from SiVal, do browse the previous five or so year volumes of Elektor and discover that you and I have been designing and connecting stuff to the Net for ages, controlling hardware and measuring data thousands of miles away or just around the corner, from our PC keyboards, eating pizza. The thing is, it was nerdy and complex. We were early adopters though.

It's hard to not see a strong presence of IoT in this edition: Connect the Magic (p. 8), ATMega on the Net (p. 16), and One Protocol for IoT (p. 58). In all articles, I've strived to concentrate on the engineering aspects of IoT, aiming to keep you in the forefront of technology where challenges are real and not reduced to do-I-buy-product-X-or-Y.

For balancing purposes this edition again has a weighty proportion of micro-controller-free projects, including a peppy amp for active speakers (p. 22), a solar-cell MPP tracker (p. 30) and a \$10 go/non-go wall wart tester (p. 56). Not a project per se but putting all this IoT stuff in a wonderful time perspective, the HP 200AB Audio Oscillator hails from the past on page 78. It is a Thing—some say a boatanchor—and its schematics are on the Internet for sure, but IoT? No. Happy reading,

Jan Buiting, Editor-in-Chief

The Team

Editor-in-Chief:	Jan Buiting
Publisher / President:	Carlo van Nistelrooy
Membership Managers:	Shannon Barraclough (USA / Canada), Raoul Morreau (UK / ROW)
International Editorial Staff:	Harry Baggen, Jaime Gonzalez Arintero, Denis Meyer, Jens Nickel
Laboratory Staff:	Thijs Beckers, Ton Giesberts, Wisse Hettinga, Luc Lemmens, Mart Schroijsen, Clemens Valens, Jan Visser, Patrick Wielders
Graphic Design & Prepress:	Giel Dols
Online Manager:	Daniëlle Mertens
Managing Director:	Don Akkermans



USA
Carlo van Nistelrooy
+1 860-289-0800
c.vannistelrooy@elektor.com



United Kingdom
Carlo van Nistelrooy
+44 20 7692 8344
c.vannistelrooy@elektor.com



Germany
Ferdinand te Walvaart
+49 241 88 909-17
f.tewalvaart@elektor.de



France
Denis Meyer
+31 46 4389435
d.meyer@elektor.fr



Netherlands
Ferdinand te Walvaart
+31 46 43 89 444
f.tewalvaart@elektor.nl



Spain
Jaime González-Arintero
+34 6 16 99 74 86
j.glez.arintero@elektor.es



Italy
Maurizio del Corso
+39 2.66504755
m.delcorso@inware.it



Sweden
Carlo van Nistelrooy
+31 46 43 89 418
c.vannistelrooy@elektor.com



Brazil
João Martins
+31 46 4389444
j.martins@elektor.com



Portugal
João Martins
+31 46 4389444
j.martins@elektor.com



India
Sunil D. Malekar
+91 9833168815
ts@elektor.in



Russia
Nataliya Melnikova
+7 (965) 395 33 36
Elektor.Russia@gmail.com



Turkey
Zeynep Köksal
+90 532 277 48 26
zkoksal@beti.com.tr



South Africa
Johan Dijk
+31 6 1589 4245
j.dijk@elektor.com



China
Cees Baay
+86 21 6445 2811
CeesBaay@gmail.com



Connects You To

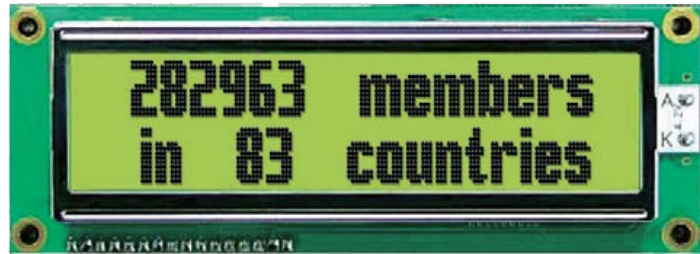

Supporting Companies

	APEC 2014 www.apec-conf.org 2
	Cadsoft www.cadsoftusa.com 92
	Cleverscope www.cleverscope.com 61
	DLP Design www.dlpdesign.com 13
	EMAC www.emacinc.com 13
	ESC (EE Live!) www.eeliveshow.com 54
	Eurocircuits www.elektorpcbservice.com 62
	Express PCB www.expresspcb.com 75
	Front Panel Express www.frontpanelexpress.com 49

	Maxbotix www.maxbotix.com/elektor 49
	Microchip www.microchip.com/get/euGC010 3
	Pico www.picotech.com/ps240 19, 21
	Pololu www.pololu.com 49
	Reichelt www.reichelt.com 35
	Saelig www.saelig.com 73
	Schaeffer AG www.schaeffer-ag.de 61
	Singex Exhibition (IoTAsia) www.internetofthingsasia.com 67
	WIZnet www.circuitcellar.com/wiznet2014 55

Not a supporting company yet?

Contact Peter Wostrel (peter@smmarketing.us, Phone 1 978 281 7708, to reserve your own space in Elektor Magazine, Elektor•POST or Elektor.com

Connect the Magic

An introduction to the WIZnet W5500

By Tom Cantrell (USA)

Are you ready to join the Internet of Things (IoT) revolution? You can start by building an innovative Net-enabled design to enter in the WIZnet “Connect the Magic” Challenge. Before you begin, read through this comprehensive introduction to WIZnet’s W5500 ‘smart’ Ethernet chip and the WIZ550io integrated module.

The microelectronics revolution is entering a new phase of mass market acceptance and application. I’m talking about the proliferation

of popular low-cost SBCs (single-board computers) that let anyone craft their own embedded application. Like magic, these platforms turn mere ‘users’ into ‘makers.’ These magic microcontrollers all share certain characteristics. The hardware itself is low cost with a range of products and add-ons, the tools (i.e. compiler and IDE) are free and easy to use and, most importantly, there’s a self-sustaining ‘community’ leveraging shared knowledge for the benefit of all.

I’ve had the pleasure of working with popular platforms such as Arduino, Texas Instruments’

LaunchPad, ARM mbed, Parallax, and others (**Figure 1**). All of them make it quick and easy, and dare I say fun, to whip out surprisingly sophisticated applications. And all have vibrant user groups with plenty of useful resources (tools, examples, advice) to share.

Now it’s time to connect all these gadgets to the ‘Internet of Things.’ Enter WIZnet and their latest and greatest ‘Smart’ Ethernet chip. The W5500 (**Figure 2**) starts with a standard 10/100 Ethernet interface (i.e. MAC and PHY) but then goes further with large RAM buffers (16-KB transmit and 16-KB receive) and hardware TCP/IP protocol processing [9].

I discovered WIZnet’s first chip, the W3100, way back in 2001 [1]. Of course by now, as with all things silicon, the new W5500 is better, faster, and lower cost. But the concept is still exactly the same: ‘Internet-enable’ applications by handling the network chores in hardware so the application microcontroller doesn’t have to do it in software. The large RAM buffers help decouple the microcontroller from network activity. In a recent project [2] I used the RAM to receive an entire 10-KB+ webpage, completely eliminating the need for the microcontroller to juggle data at network speed. And any of the 32-KB on-chip RAM that isn’t needed for network buffering is free for general-purpose use, a big plus for typically RAM-constrained microcontrollers.

The other major WIZnet hardware assist is TCP/IP processing using IP addresses, sockets, and familiar commands including OPEN, CONNECT,



WIZnet Connect the Magic Challenge

March 3, 2014 – August 3, 2014.

Visit CircuitCellar.com/wiznet2014:

- Request free WIZ550io modules
- Learn how to register and enter the Challenge
- Read the rules and regulations
- Find out about prize information
- And more



Sponsored by WIZnet — circuitcellar.com/wiznet2014

SEND, RECEIVE, DISCONNECT. The high-level interface to the network frees up microcontroller cycles and code space that would otherwise be needed for a software TCP/IP stack.

Disappearing Act

The WIZ550io pictured in **Figure 3** is an integrated module that includes everything you need to get online.

Connecting the WIZ550io to your favorite micro-controller is easy. There's just an SPI (MISO, MOSI, SCLK, SCSn), three status/control lines (RESETn, RDY, INTn) and power and ground. Note 'n' suffixed to signal names indicates Active Low. The WIZ550io power supply is 3.3 V, but the module inputs are all 5-V tolerant.

Ideally your processor has a hardware SPI port that can take advantage of the WIZnet modules high-speed (up to 80 MHz) SPI. But if not, bit banging is fine since the W5500 RAM buffers will take up the slack for a slow microcontroller connection.

As for the three control lines, you can connect them or not, depending on the particulars of your application.

RESETn does a hardware reset of the module, but the automatic power on reset will typically suffice. Alternatively, you can do a little house-keeping (save the current network parameters) and issue a software reset.

After hardware reset (i.e. power on or RESETn), the RDY output will assert after a delay (50 ms) for internal module initialization. Instead of dedicating a pin to monitor RDY, it's easy to just insert a software delay when the application starts.

The INTn pin is there if you want to implement an interrupt driven interface. Software can define which particular event(s) (e.g. data transfer, socket disconnect, link loss, etc.) trigger an interrupt request. But with the W5500 handling most network activity, there's no need to interrupt the microcontroller in normal operation. The network can be dealt with in the background leaving interrupts free for real-time tasks that truly need them.

How many times have you gotten near the end of a project and discovered you really need one more I/O line? The W5500 offers an optional fixed transfer length SPI mode that works with the chip select (SCSn) input grounded. However, fixed mode only supports short transfers (1, 2, or 4 bytes), not the arbitrarily large block transfers

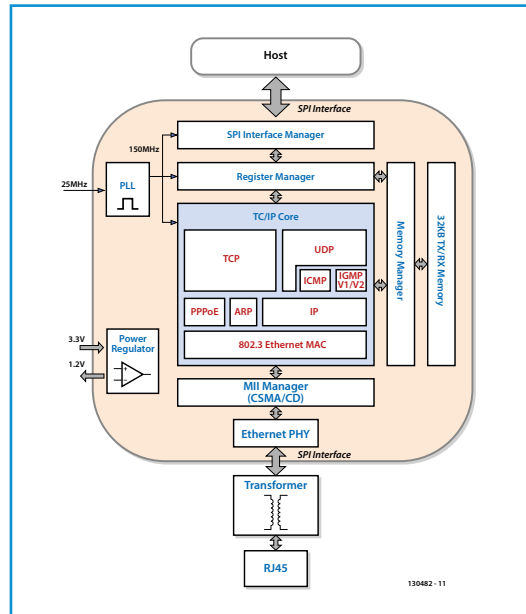

Figure 1. The WIZnet W5500 is an Ethernet chip with a difference: large RAM buffers and hardware TCP/IP protocol processing make it easy for any microcontroller to go online.

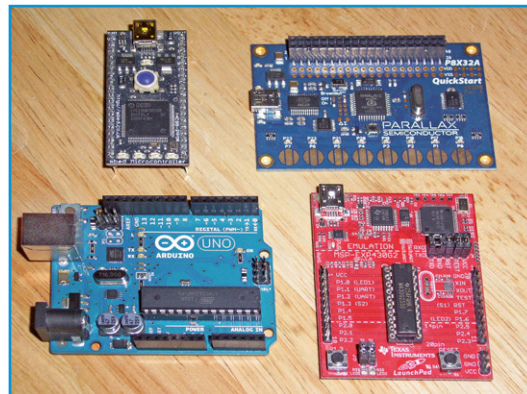

Figure 2. Magic tricks are easy when you've got the right Cards up your sleeve.

possible using SCSn, so only consider it as a last resort if you're really desperate to free up a pin.

Hidden Wires

Blasting data fast and far is Ethernet's claim to fame, but that requires a lot of power (e.g. 100+ mA) just to maintain the link (i.e. PHY enabled). Fortunately, the W5500 has a standby mode that drops the link (i.e. disables the PHY) reducing the W5500 power consumption by a factor of 10, as well as that of the un-linked partner. Having an AC outlet nearby gives you the option of piggybacking your Ethernet data onto the power lines. That's exactly what I do with my

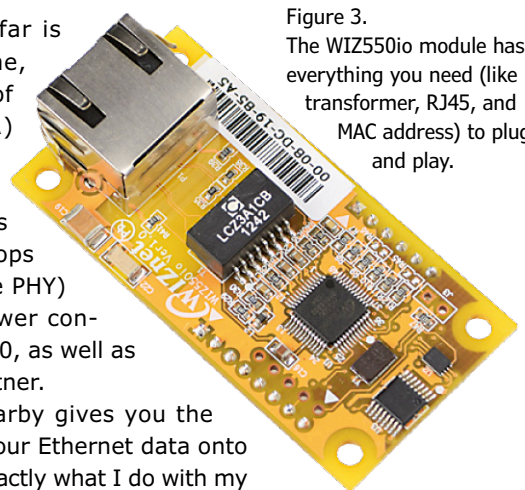

Figure 3. The WIZ550io module has everything you need (like transformer, RJ45, and MAC address) to plug and play.

Figure 4.
My garage door monitoring 'Thing' uses a powerline adapter to connect with the household LAN.

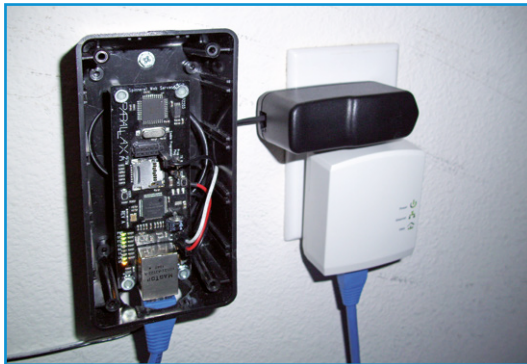

Figure 5.
All you need are some cheap 'cheater g' cables (splitter and injector) and a variable power supply to homebrew your own Passive PoE solution.



Figure 6.
Low-cost Mobile Hot Spots like this TP-Link NanoRouter make it easy to convert Ethernet to Wi-Fi without any software changes.

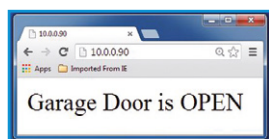

Figure 7.
My garage door 'Thing' doing its thing.

own garage door monitoring 'Thing' appearing in **Figure 4**). Shop around and you'll find there are powerline communication (PLC) 'starter kits' that come with a pair of adapters (like my Rosewill RPLC-201KIT) in the \$20 to \$40 price range. If you're recalling the shaky early days of power line communication, be advised the latest generation of gear works a lot better. There can still be situations where particular AC outlets are hard to reach, but usually you can find a nearby one with a decent connection. Since these new adapters are designed to handle streaming AV, I've found that even marginal connections (as indicated by the adapters signal quality LED) work fine with my low-bandwidth apps. Presumably the powerline adapter and/or W5500 are working their own magic handling any issues (e.g. automatic retry

of corrupted/lost packets,) which is fine by me. If there isn't AC nearby and you're faced with stringing wire, Power-over-Ethernet (PoE) is the way to go. It's perfect for things like security webcams and VoIP phones, and now the popularity of those applications has fueled the market with new suppliers and lower prices (sub \$100 routers; sub \$10 modules) for IEEE standard 802.3af PoE gear.

An even simpler roll-your-own option is 'Passive PoE' that use the four spare wires in a standard Ethernet cable for power transmission (see **Figure 5**). Note that this hack doesn't work with Gigabit Ethernet (which uses all eight wires) or 'Active PoE' (i.e. IEEE standard 802.3af) gear—just plain vanilla 10/100.

You may have to consider voltage drop, especially for long cable runs (up to 300 ft. / 100 m) and/or high-current loads. Use a 'PoE Calculator,' such as the one available from Stephen Foskett's PoE Blog [3] to estimate the voltage drop depending on your cable length and current requirements. Or just wire everything up and dial it in using a variable power supply while measuring the actual voltage at the far end. Make sure your device is attached and fully active (i.e. pulling maximum expected current, not sleeping, etc.) to get an accurate voltage reading.

Mindreader

If your heart is set on wireless you can always add a low-cost Wi-Fi adapter. The TP-Link NanoRouter I've been using (**Figure 6**) is quite versatile with five different configuration options: Router, Access Point, Bridge, Repeater, and Client. Your attached Ethernet device can either join an existing wireless network or you can create an additional network with its own SSID.

Thanks to the march of technology, the dual Ethernet + Wi-Fi approach is getting more affordable. The WIZnet online store has the WIZ550io for \$18 (the W5500 chip is just \$2.62) and you can find TP-Links online for \$20 or so. By comparison, if you Google 'embedded Wi-Fi module' or 'Wi-Fi shield' you'll see a variety of different products ranging from around \$20 for a bare Wi-Fi module (no PCB) to \$80 for an official Arduino Wi-Fi Shield. Indeed, the large variety of Wi-Fi solutions does have a downside. There are more than a few embedded Wi-Fi chipsets in popular use (e.g. Broadcom, Gainspan, Microchip, Texas Instruments, no doubt more on the way), each with their own capabilities and unique commands. The

prospect of trying to write and support drivers for all the Wi-Fi chipsets across all the popular platforms gives me a headache. With the dual approach, it's easy to move Ethernet apps (any app, any platform) to Wi-Fi. Just plug into the TP-Link and you're done without changing a line of code—that's the kind of magic trick I like!

Server Up My Sleeve

Everyone wants to be *Master of the IoT Universe* from their browser screen. With assistance from WIZnet, even tiny microcontrollers are capable of running a simple web server. Checkout **Figure 7** showing the webpage served up by my garage door 'Thing'.

But you can see the problem; or rather you can't see it. Where are the high-resolution graphics that a pixel-jaded populace demands? No way to cram more than a bit of HTML/JavaScript/JPG eye candy into the microcontroller itself, so you'll have to conjure up some external memory if you want to spice things up.

The most popular add-on is a MicroSD card which, like the W5500, uses a SPI bus so you just need one extra pin for chip select. Using a standard file system driver (like FAT) you can actually do much of the development and testing of your 'website' on a PC, then when you're finished, just plug the SD card into your IoT gadget.

For prototyping, check out the WIZnet ioShield pictured in **Figure 8**, which is a baseboard for the WIZ550io that includes an SD card socket. There are ioShields for different platforms (e.g. Arduino, LaunchPad, mbed, etc.) and with 0.1" headers they are breadboard friendly.

Presto Change-O

Since your browser is a 'client' it makes sense that every IoT gadget should be a 'server'—right? Not necessarily. Being a server typically implies being open for service 24/7, but many IoT applications (e.g. my garage 'Thing') are characterized by intermittent low duty-cycle activity. And while running on a LAN works fine, there may be issues reaching an in-house server from the WAN due to firewalls, ISP restrictions, changing IP addresses, and the like. Besides, do you really want to let the outside world anywhere near your LAN? Maybe it makes more sense for IoT gadgets to be clients.

But how do you get two clients (i.e. IoT device and browser) to talk to each other? The answer is you stick a server in between them courtesy

of a 'Device Cloud' provider such as Xively (was Pachube), Exosite, DeviceHub, ThingSpeak, Nimbits, XOBXOB, the list goes on and on. (Postscapes provides an extensive list) [4].

Much as the WIZnet chip offloads network chores, these services handle data storage and visualization to make life easy for the IoT application. Just send your raw data and the service will archive it, present it to a browser as a graphical chart, and send an e-mail, text, or tweet alert if you like. Better yet, you don't need any specialized web programming tools or know-how to get something useful working quickly.

The technical capabilities and look and feel of each device cloud service differ, as do their business models, everything from for-profit and pay-to-play to free and open source. But from 50,000 feet all work in a similar way. To send data to the cloud, the IoT client hits the cloud server with a request that carries the data (e.g. variable name and value) in the URL or the request body. To get data from the cloud, the IoT device sends a request specifying a variable and then retrieves the data from the server response.

I decided to get my head in the clouds by prototyping a client version of my garage door "Thing" (**Figure 9**) using an Arduino a WIZ550io [5]

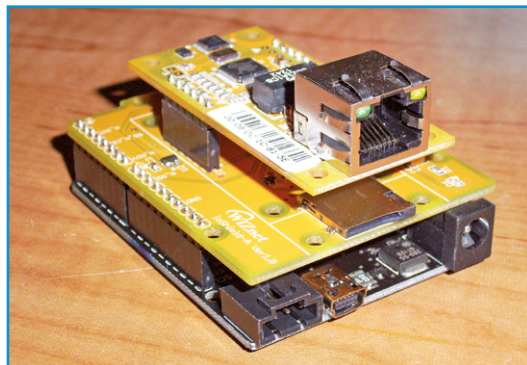

Figure 8. If you want a fancy server with lots of eye candy, a MicroSD card is the way to go. The WIZnet ioShields' include the card socket and are available for various platforms. The Arduino version is shown here.

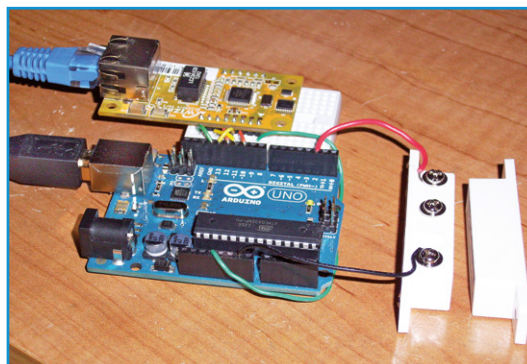

Figure 9. Prototype of the client version of my garage "Thing".

```

void loop() {
  static unsigned long sendPrevTime = 0;
  static unsigned int prevPos, currPos; // door previous & current position
  currPos = digitalRead(2); // pin d2 = 0/1 = door is closed/open
  if ((currPos != prevPos) || ((millis() - sendPrevTime) > HEARTBEAT)) {
    prevPos = currPos;
    W5100.setPHYCFGR(0x3C); // power-up Wiz (phy enable)
    W5100.setPHYCFGR(0xDC); // power-up Wiz (phy enable)
    String writeParam = "Fin D2="; // Exosite variable to write
    writeParam += String(currPos); // append write data as string
    String readParam = ""; // no read data for this app
    String returnString = ""; // Exosite response
    if (exosite.writeRead(writeParam, readParam, returnString)) {
      sendPrevTime = millis(); // reset heartbeat timer
    }
  } else {
    sendPrevTime = millis() - HEARTBEAT + 5000; // error, retry in 5 seconds
  }
  W5100.setPHYCFGR(0xF0); // power-down Wiz (phy disable)
  W5100.setPHYCFGR(0x70); // power-down Wiz (phy disable)
}

```

Figure 10. There's an Exosite library for Arduino that makes accessing the cloud easy as can be.

connected to Exosite.

Note I'm powering the WIZ550io from the Arduino 3.3-V supply. That works for newer Arduinos (e.g. my UNO R3) that have a 150-mA, 3.3-V regulator. To work with earlier Arduino or clones that only specify 50 mA, a real 'shield' (e.g. the WIZnet ioShield) will include a 3.3-V regulator running off the 5-V supply.

The Arduino code (**Figure 10**) just sits in a loop checking to see if the door state changes or it's time to send a heartbeat. Then it takes little more than a single function call (`exosite.writeRead`) to fire the door state off into the Exosite cloud. Over on the Exosite website [6], after signing up for a free 'Developer' account it was a quick and easy mainly point-and-click exercise to configure my 'Device,' 'Data,' 'Events,' and 'Alerts' (**Figure 11**).

As a client, there's no need to keep the Thing's Ethernet link powered all the time. Data only needs to be sent when the garage door opens or closes, but I also recommend sending a periodic heartbeat just in case. My garage door monitor will only generate a minute or two of network activity (i.e. door state changes and hourly heartbeats) per day, so there's opportunity for significant energy savings compared to a 24/7 server.

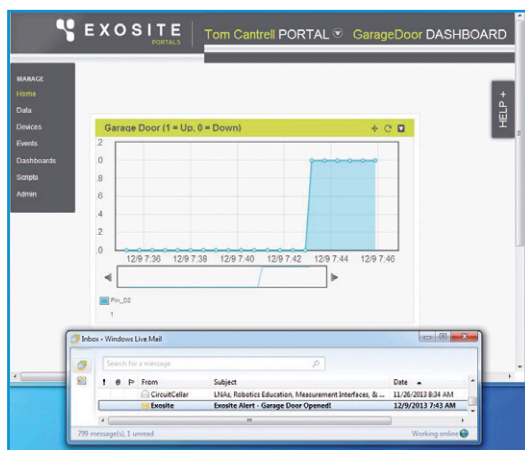

Figure 11. It only takes a few minutes to set up a simple Exosite Dashboard including an e-mail alert. I can 'see' my garage door without getting off the couch and now, via Exosite, from the farthest reaches of the web.

Learn Some Tricks

At WIZnet's 'Connect the Magic' web page you can find the props for your own Magic show. There's support for the WIZnet hardware (i.e. W5500, WIZ550io, and ioShields) as well as links to W5500 drivers and demos for third party and

References and Web Links

- [1] I-Way the Hard Way, T. Cantrell, *Circuit Cellar* 135, 2001.
- [2] Weatherize Your Embedded App, T. Cantrell, *Circuit Cellar* 273, 2013.
- [3] Power Over Ethernet Calculator, Blog, S. Foskett, <http://blog.fosketts.net/toolbox/power-ethernet-calculator>
- [4] IoT Data Broker and Cloud Service Providers, <http://postscapes.com/companies/iot-cloud-services>.
- [5] WIZnet, 'Connect the Magic' Resources, <http://wizwiki.net/wiki/doku.php?id=connectthemagic>.
- [6] Exosite Device Cloud: www.exosite.com

Hardware Sources

- RPLC-201KIT AV adapter starter kit: www.rosewill.com
- TL-WR702N 150 Mbps Wireless N NanoRouter: www.tp-link.us
- W5500 Ethernet controller: wizwiki.net

The Author

Tom Cantrell (microfuture@att.net) has been working on chip, board, and systems design and marketing for several years.

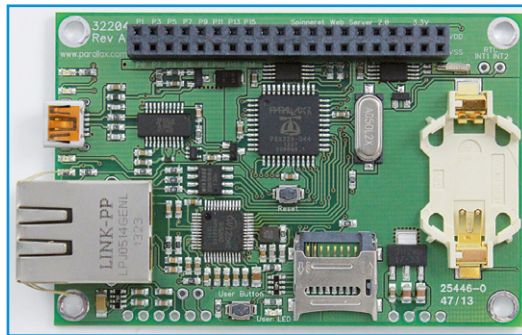

Figure 12. The Parallax Spinneret Web Server 2.0 is one of the first platforms available featuring the W5500.

open-source hardware including Arduino, Launch-Pad, mbed, and Parallax (Figure 12). The W5500 also works with some interesting platforms I haven't used before. Cookie and chipKIT are Arduino form-factor SBCs that uses ARM Cortex and Microchip PIC32 microcontrollers, respectively. GR-KURUMI is a Japanese variation on the mbed theme (i.e. web-based tools) using a Renesas microcontroller. If you want to leverage existing big iron network software, there's even

a BSD Sockets library based on the UC Berkeley open-source UNIX derivative. The combination of magic micros with the W5500 and all the new device cloud services makes a compelling case for connection. Put 'em all in your hat, wave your magic wand, and amaze your friends with the cool 'thing' you pull out. (130482)

Advertisement

USB Add USB to your next project. It's easier than you might think!

DLP-USB1232H: USB 2.0 UART/FIFO

HIGH-SPEED

480Mb/s



Only \$28.95!

- Multipurpose: 7 interfaces
- Royalty-free, robust USB drivers
- No in-depth knowledge of USB required
- Standard 18-pin DIP interface; 0.6x1.26-inch footprint

DLP-IO8-G

8-Channel Data Acquisition

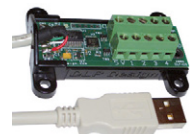

Only \$29.95!

- 8 I/Os: Digital I/O
- Analog In
- Temperature
- USB Port Powered
- Single-Byte Commands

DLP-IOR4

4-Channel Relay Cable

DLP-TH1b

Temp/Humidity Cable

DLP-RFID1

HF RFID Reader/Writer

DLP-FPGA

USB-to-Xilinx FPGA Module



www.dlpdesign.com

Ultra Small Panel PC

PPC-E4+

- ARM9 400Mhz Fanless Processor
- Up to 1 GB Flash & 256 MB RAM
- 4.3" WQVGA 480 x 272 TFT LCD
- Analog Resistive Touchscreen
- 10/100 Base-T Ethernet
- 3 RS232 & 1 RS232/422/485 Port
- 1 USB 2.0 (High Speed) Host port
- 1 USB 2.0 (High Speed) OTG port
- 2 Micro SD Flash Card Sockets
- SPI & I2C, 4 ADC, Audio Beeper
- Battery Backed Real Time Clock
- Operating Voltage: 5V DC or 8 to 35V DC
- Optional Power Over Ethernet (POE)
- Optional Audio with Line-in/out



Designed and Manufactured in the USA the PPC-E4+ is an ultra compact Panel PC that comes ready to run with the Operating System installed on Flash. The dimensions of the PPC-E4+ are 4.8" by 3.0", about the same as that of popular touch cell phones. The PPC-E4+ is small enough to fit in a 2U rack enclosure. Apply power and watch either the Linux X Windows or the Windows CE User Interface appear on a vivid 4.3" color LCD. Interact with the PPC-E4+ using the responsive integrated touch-screen. Everything works out of the box, allowing you to concentrate on your application rather than building and configuring device drivers. Just Write-It and Run-It. Pricing starts at \$375 for Qty 1.

www.emacinc.com/sales/elektor14

Since 1985
OVER
29
YEARS OF
SINGLE BOARD
SOLUTIONS

EMAC, inc.
EQUIPMENT MONITOR AND CONTROL

Phone: (618) 529-4525 • Fax: (618) 457-0110 • Web: www.emacinc.com

Elektor World

Compiled by
Wisse Hettinga

Every day, every hour, every minute, at every given moment designers and enthusiasts are thinking up, tweaking, reverse-engineering and developing new electronics. Chiefly for fun, but occasionally fun turns into serious business. Elektor World connects some of these events and activities — for fun and business.

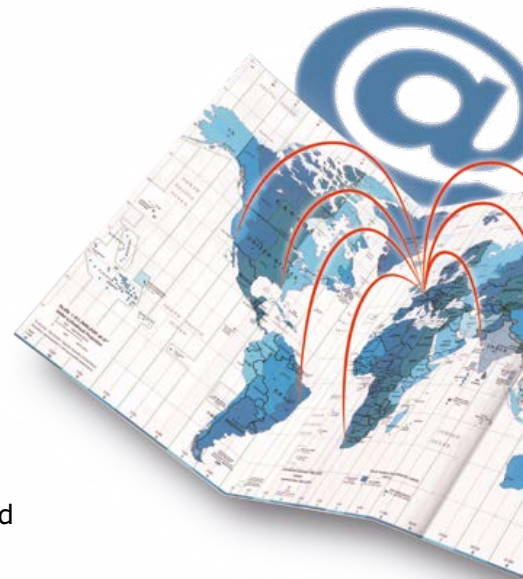

Who's looking in your fridge?

If we are to believe the predictions the year 2014 will see the dawn of the Internet of Things—all things. Your fridge, your car, your audio equipment, all and everything will be able to start communicating in a smart way. That will ask for drastic security measures. Writing this article I am just reading in the news that hackers used a fridge to get access to a home automation system.

Elektor joined forces with Spanish company Intelligent SOC to launch the Secure Internet Chip. It can be used to secure all your internet communications. Pictured here are Carlos Ponce de León with Maria and Jaime from Elektor signing the contract. At Elektor we are busy with the tech preparation of this unique project and the production of the boards. Tentatively in the April 2014 editions Elektor will run a challenge to launch the product—there will be \$25,000 prize money for the first code breaker!



Don't touch—just wave

Jean-Noel Lefebvre drove more than 450 miles from Lyon in France to Limbricht in The Netherlands. In his car was a box—and in that box another box to demonstrate the Ooutsidebox.

Jean-Noel is a lifetime Elektor reader. He is also an 'out-of-the-box thinker' and as a result of that he comes up with the most interesting projects and ideas. One of them is the Ooutsidebox project, a capacitive sensing frame that can be fitted around your Tablet PC. It detects and calculates the movement of your hand and allows complete control of the system with easy gestures—you just have to wave! This means you can start playing games without touching the screen—you can use your hand like special small bat to play Pong like you have never done before or, if you are a programmer, you can think up a thousand other applications ranging from hygienic control systems to ice-cold situations when you cannot take off your gloves to control a tablet. We have agreed to team up with Jean-Noel and embark on a new project that will show you how to implement gesture control on your own projects and systems. Later this year hopefully we will develop some new initiatives to launch the Ooutsidebox project.

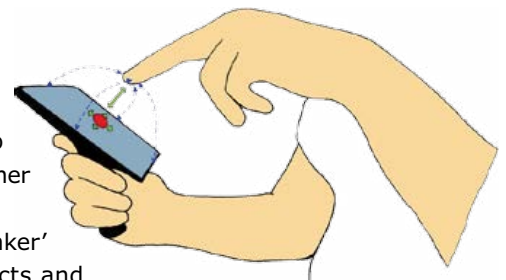

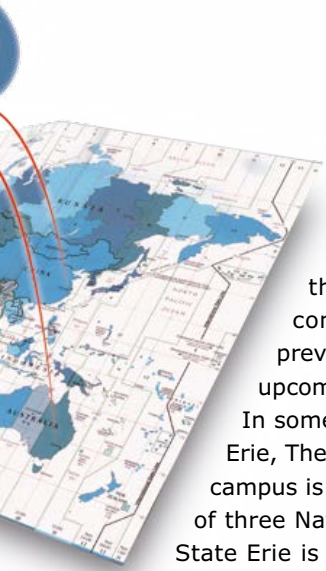

Raspberry to the rescue

Enterprising employees at two very different US schools have at least one thing in common: They devised Raspberry Pi-based solutions for vexing communication issues their students were faced with. Both projects are previewed online in *Circuit Cellar* (bit.ly/LHjmHD) and will be fully described in upcoming issues of the magazine.

In some ways, Salish Kootenai College (SKC) based in Pablo, MT, and Penn State Erie, The Behrend College in Erie, PA, couldn't be more different. SKC, whose main campus is on the Flathead Reservation, primarily serves students who are members of three Native American tribes. It has an enrollment of approximately 1,400. Penn State Erie is a fast-growing campus with roughly 4,300 students just outside one of Pennsylvania's larger cities.

Each campus had a problem. At SKC, dorm residents had poor access to the Internet. At Penn State Erie, students weren't riding the newly introduced campus shuttle bus to class because of its unpredictable schedule. SKC IT Director Al Anderson and his team direct-wired the dorms to provide students better Ethernet service and built a Raspberry Pi-based system to monitor potentially damaging temperatures inside the dorms' sun-exposed utility boxes. Meanwhile, Penn State Erie Professor Chris Coulston and his group built an automated vehicle locator (AVL) that tracks their campus shuttle bus on a web page that students download to their smartphones. The system's base station consists of a wireless modem connected to a Raspberry Pi, which runs a web server to handle smartphone requests (pictured here).

The base station for the Penn State Erie mobile tracker sandwiches a Raspberry Pi, an interface board, and a wireless modem.



The space-time existence of the zero-ohm resistor

Every month we run a short article on the lives of Weird Components. We do this together with the DesignSpark initiative from RS Components. In the January & February 2014 edition I discussed the existence of the 0-ohm resistor. Thomas Scherer, regular contributor and electronics designer from Germany was triggered and took the free thinking to the next level—towards infinity. If you start philosophizing about a 0-ohm resistor the next thing to conclude is that there must be an infinite capacitance and a 0-H inductance concurrently. In fact, you virtually created a new 3-in-1



component which I would venture to call the *Zerfinite*. It has all the zero and infinite values and acts like a resistor, a capacitor and inductor in one. Using components like these will help you create filters with infinite bandwidth in a time/space moment of zero/everywhere! New and exciting products can be designed using this new component. Great stuff, a new technology is born! I will contact RS Components directly and propose they add the novel 'component' to their stock line so you can order it and play around with it. (if you ever might wonder how we spend our valuable time ... here's one answer.)

ATmega on the Internet (1)

Using Raspberry Pi as a network gateway

By **Dieter Holzhäuser**
(Germany)

Communicating with a microcontroller over the Internet is easy. All you need is a networked PC or smartphone, a local area network (LAN), and another computer connected to the ATmega32 over a serial link. The basis for this series of articles is a system in which a Fritz!Box router provides the LAN, and a Raspberry Pi is used as a network gateway. In the first instalment we present the basic concept and describe some typical hardware.



Figure 1.
A Raspberry Pi in practical use.

The Raspberry Pi, which is roughly the size of a credit card, is a simple Linux PC. The “Model B” version, with 512 MB of RAM and an Ethernet port (see **Figure 1**), costs about 40 dollars. A monitor can be connected to its HDMI output, and its two USB 2.0 ports are used for a keyboard and a mouse. Power is supplied to the Raspberry Pi through a Micro USB connector. With a power consumption of less than 3 watts, it’s no power glutton, so it can be left on all the time. After all, there wouldn’t be much point in using a computer that is only occasionally powered up as an access point for the Internet.

OS aspects

The current OS, Raspbian wheezy, can be downloaded free of charge from the Internet as a disk image [2]. However, it can also be obtained as a pre-installed version on an 8-GB MicroSD card

with SD adapter, with about 6 GB unused. It’s really amazing that a computer this small can support a graphical user interface. However, in this project we use the command line interface instead. The software behind this is called a shell. You can access the command line interface of the shell by launching *LXTerminal* or by exiting the graphical user interface. If you don’t want to use the graphical user interface at all, you can alter the configuration settings with the *raspi-config* utility to prevent the GUI from autostarting after a system boot. To run this utility using the command line interface, enter:

```
sudo raspi-config
```

The prefix *sudo* allows regular users to use system calls normally reserved for the root user (Superuser).

The procedure is largely self-explanatory. In the line:

```
boot_behaviour      Start desktop on boot?
```

use the Tab key to set the focus on <Select>, press Enter, and then give the appropriate answer to the subsequent question:

```
Should we boot straight to desktop?  
<Yes>      <No>
```

If you say <Yes>, the graphical user interface will appear every time after booting (without login); if you say <No>, the command line interface will appear (with login). If for some reason you want to use the graphical user interface later on, you

can launch it manually with *startx*. Communication between the shell and the user's terminal device, which is also called the console, consists of sending characters or character strings back and forth. It doesn't matter where the terminal device is located or how it is connected to the computer.

The abbreviation commonly used in Linux for a character-oriented terminal device is *tty*, which is short for "teletypewriter"). In Linux this means not only the terminal itself, but also the computer port to which the terminal can be connected.

Serial interface

The local terminal, consisting of the keyboard and monitor connected to the Raspberry Pi, does not need a physically accessible interface. However, the Raspberry Pi does provide a simple serial interface. It is brought out to the two-row pin header and configured such that after booting, a user can log in to a shell using a terminal connected to the serial port.

However, this is not what we want. Instead, we want to use this interface to allow an ATmega32

to communicate with a terminal. Two things are necessary for this. The first is to eliminate the configuration of the serial interface as the console. The second is to convert the Raspberry Pi into a terminal that uses this interface. This means that all keyboard inputs to the Raspberry Pi are passed on directly over the interface and all received characters are output to the monitor. To get rid of the existing configuration of the serial interface, you have to edit two text files. Open the first file by calling the command line editor *nano*:

```
sudo nano /etc/inittab
```

At the end of the displayed text there is a line with the following (or similar) content:

```
T0:23:respawn:/sbin/getty -L ttyAMA0
115200 vt100
```

Place a hash mark (#) at the start of this line to change it into a comment. After this change, the serial interface (the internal device *ttyAMA0*) will ignore console input and output. Save the edited file and exit the editor.

Even with this change, the boot-up data is still

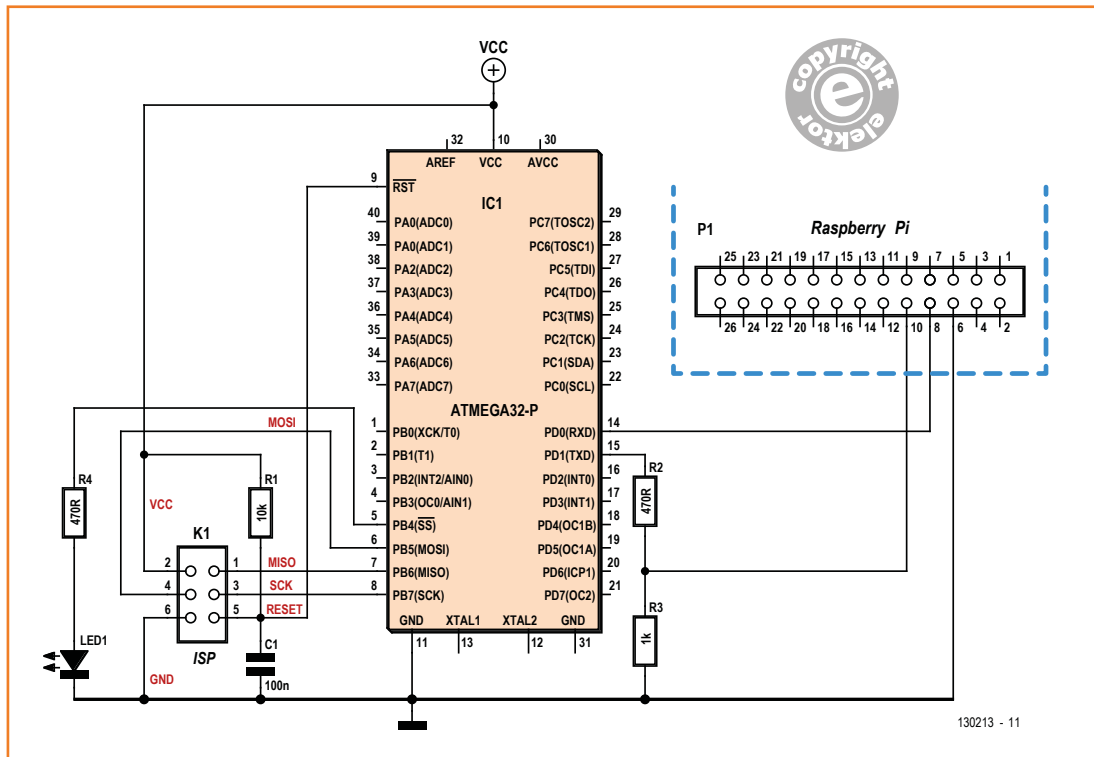

Figure 2. The serial link between the ATmega32 and the Raspberry Pi.

Listing 1: suidemo1.c

```
1 #include <avr/interrupt.h>
2 #include <avr/io.h>
3
4 #define BAUDCODE      12                // 4.800 Baud @ 1 MHz
5 #define INITLED      DDRB = DDRB | 1<<4;
6 #define TOGGLELED    PORTB = PORTB ^ 1<<4;
7 #define ISLEDON      PORTB & 1<<4
8
9 unsigned int cycle = 500;
10 unsigned long clock = 0;
11 unsigned long old = 0;
12 unsigned char chr;
13 unsigned char ontxt [] = "\r1|5 *** ";
14 unsigned char offtxt [] = "\r1|5      ";
15 unsigned char * ptxt;
16
17 ISR ( TIMER0_COMP_vect ){                //Interrupt Service Routine Timer
18     if ( !(clock++ % cycle) ) {
19         TOGGLELED
20         if (ISLEDON) ptxt = ontxt; else ptxt = offtxt;
21         UDR = *ptxt ;
22     }
23 }
24
25 ISR ( USART_TXC_vect ) {                 //Interrupt Service Routine Transmit
26     ptxt++;
27     if (*ptxt != 0) UDR = *ptxt;
28 }
29
30 ISR ( USART_RXC_vect ) {                 //Interrupt Service Routine Receive
31     chr = UDR;
32     if (clock - old > 50) {
33         old = clock;
34         if (chr == '5') cycle = 500;
35         else if (chr == '1') cycle = 100;
36     }
37 }
38
39 int main(void) {
40     TCCR0 = 0x08;                        // Init Timer CTC-Mode
41     TCCR0 = TCCR0 | 0x02;                //Prescaler: 1 MHz: 8 = 125 kHz, 0x02; 16 MHz: 64 = 250 kHz, 0x03
42     OCR0 = 124;                          //Compare 1 MHz: 124; 16 MHz: 249
43     TCNT0 = 0;                            //TimerCounter on 0
44     TIMSK |= 1<<OCIE0;                    //enable CTC-Interrupt Timer0
45     UBRRH = (unsigned char) (BAUDCODE >> 8); //Init USART
46     UBRRL = (unsigned char) BAUDCODE;
47     UCSRB = UCSRB | (1<<RXEN) | (1<<RXCIE) | (1<<TXEN) | (1<<TXCIE) ;
48     sei();                                  //Enable Interrupts
49     INITLED
50     while (1) ;
51     return 0;
52 }
```

sent to the serial interface, To prevent this, call the editor again with the second file:

```
sudo nano /boot/cmdline.txt
```

In the displayed text

```
dwc_otg.lpm_enable=0 console=ttyAMA0,115200
kgdboc=ttyAMA0,115200 console=tty1 root=/dev/
mmcblk0p2 rootfstype=ext4 elevator=deadline
rootwait
```

delete the two references to *ttyAMA0*. The modified text is:

```
dwc_otg.lpm_enable=0 console=tty1 root=/dev/
mmcblk0p2 rootfstype=ext4 elevator=deadline
rootwait
```

Save the edited file and then restart.

The Raspberry Pi needs a terminal emulator program in order to act as a terminal. One option for this is the program *picocom*. First you have to download and install the program. The command for installing the program is:

```
sudo apt-get install picocom
```

The installation process is automatic. You don't have to do anything else. To launch the program, type:

```
picocom -b 4800 /dev/ttyAMA0
```

Here *-b 4800* sets the baud rate and */dev/ttyAMA0* is the device file for the serial interface. You don't have to type this command again every time you need it. Instead, you can use the Up and Down arrow keys to scroll through previously entered commands and retrieve them to the command line.

For your first test, connect pin 8 (TxD) and pin 10 (RxD) together on pin header P1 (see **Figure 2**). Now the characters you type on the keyboard will appear on the monitor. To exit the terminal emulator program *picocom*, press the key combination Ctrl-A-X.

ATmega32

In order for two devices to communicate over a serial interface, they must have the same transmission parameter settings. The only configurable parameter for the simple serial interface of the Raspberry Pi is the baud rate. The frame format and the mode bits are permanently set to eight data bits, no parity, one stop bit and no handshaking. The *picocom* program and the serial interface of the ATmega32 are preconfigured with these settings. The only parameter you need to set in software is the baud rate, and pins 14 (RxD) and 15 (TxD) of the ATmega32 must be configured for the serial interface.

7-in-1eders of Picoscope

1. Oscilloscope
2. Spectrum analyzer
3. Function generator

And for the

8th...

4. AWG
5. Logic analyzer
6. Serial protocol analyzer
7. Automatic waveform test

www.picotech.com/PS240

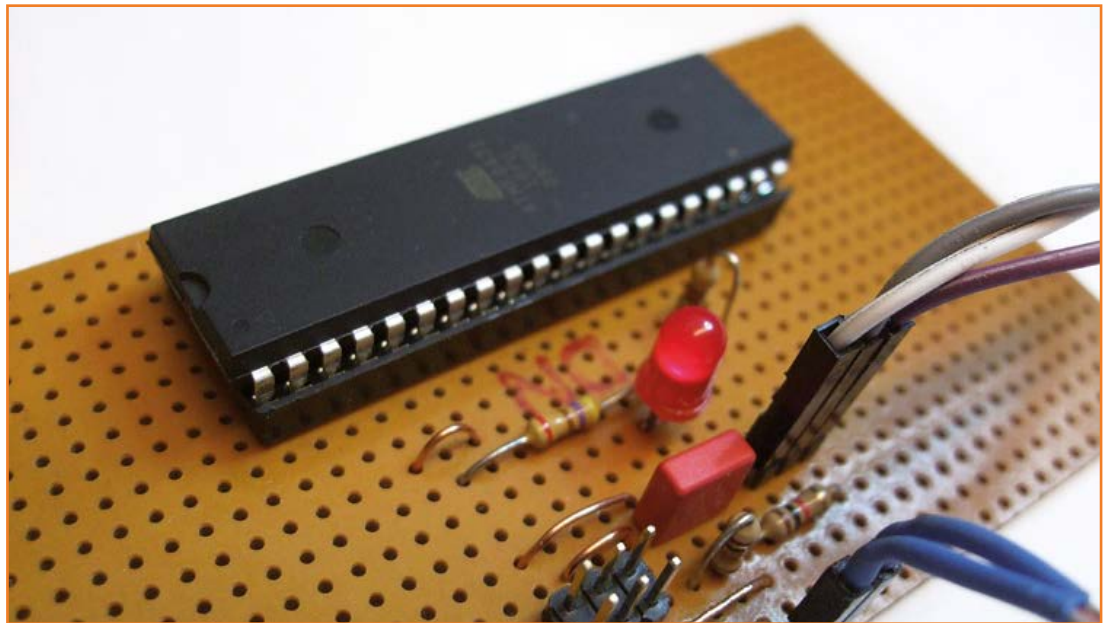

Figure 3.
The ATmega32 on a piece of prototyping board.

For experimenting, it's helpful to mount the ATmega32 on a piece of prototyping board (see **Figure 3**). It's ready to run after an external circuit or signal is connected to the reset input. The device is factory-configured to operate from its internal clock source, which runs at 1 MHz. A programming device, such as the AVRISP mkII, can be connected to the 6-pin pin header K1. Information about setting up a development environment can be found on the Internet [3]. Connect R1 and C1 to the Reset input.

Connect the TX and RX pins of the microcontroller to the corresponding pins of the 26-pin pin header P1 on the Raspberry Pi board. The voltage divider formed by R2 and R3 ensures compliance with the 3.3-V signal level requirement of the Raspberry Pi board. Check carefully to ensure that you have made the right connections, since the Raspberry Pi can be permanently damaged by incorrect connections.

Connect an LED to pin 5 (PB4) of the ATmega32

to allow program activity to be observed (e.g. the activity of the simple C program described below).

Demo program *suidemo1.c*

The *suidemo1.c* program shown in **Listing 1** is intended to be used as a demo and for experimenting. It consists of the *main* function, which contains the main loop, and three interrupt service routines (ISRs).

The program causes the LED to blink at two different rates. A simple user interface is implemented in the form of characters that are output and displayed on the Raspberry Pi monitor. They show the state of the LED. You can change the blink rate by pressing a key on the keyboard.

In lines 40 to 44 *Timer0* is initialized to cause the *ISR_TIMER0_COMP_vect* to be called at a frequency of 1 kHz. The ISR increments the variable *clock*, which acts as an internal clock. In lines 18 and 19, the variable *cycle* is used to derive the LED blink rate from the value of *clock*. On each state change the pointer *ptxt* is set to the text

Web Links

- [1] Author's website: www.system-maker.de (in German)
- [2] Raspian wheezy download: www.raspberrypi.org/downloads
- [3] Information about IDEs and programmers: www.system-maker.de/avr.html (in German)
- [4] ATmega32 data sheets: www.atmel.com/devices/atmega32.aspx
- [5] Elektor web page for this project: www.elektor-magazine.com/130213

string to be transmitted over the serial interface (line 20) in order to display the new state of the LED on the monitor. Transmission is initiated by writing the first character of the text string to the register *UDR* (line 21).

The ISR *USART_TXC_vect* is responsible for sending the rest of the characters. It is called each time the transmit shift register becomes empty. That is why this ISR can only transmit the second and subsequent characters. The ISR stops transmitting when the null character marking the end of the string is detected (line 27).

The ISR *USART_RXC_vect* is called each time a character from the terminal keyboard has been received completely. First the register *UDR* must be read out (line 31). Key-strokes that send more than one character can be recognized from the arrival rate of the characters. However, character sequences of this sort are not used in this program. For this reason, if the time since the last ISR call when a new character arrives is distinctly less than the usual time between keystrokes, the character is discarded (line 32). Only keys 1 and 5 are significant. They change the LED blink rate by altering the value of the variable *cycle* in lines 34 and 35. The serial interface must be initialized before it can be used; this is done in lines 46 to 48. The baud rate is set by writing a number that depends on the clock frequency (see the ATmega32 data sheet [4]) to the registers *UBRRH* and *UBRRL*. The maximum supported baud rate with a clock frequency of 1 MHz is 4,800. The interrupt enable bits for the transmit and receive functions must also be set. The bits of the Status and Control register *UCSRC* are initialized automatically after a reset to correspond to the frame format.

The endless loop in line 50 keeps the program active. The program is controlled exclusively by the *Timer0* events and the terminal keyboard.

The serial user interface only responds to keys 1 and 5. It also shows the current LED state in a single line on the terminal monitor. When the LED is lit, the line reads:

```
1|5   ***
```

Now we have effectively implemented a remote control mechanism that allows the ATmega32 to be controlled over a serial interface.

In the next instalment of this mini-series, we show you how to use this combination of a Raspberry Pi computer and an ATmega32 in a local area network and how it can be controlled over the Internet from anywhere in the world.

(130213-I)

pico[®]
Technology

8 CHANNEL PC Oscilloscope for just £1395

- High resolution • USB powered
- Deep memory



... 8th

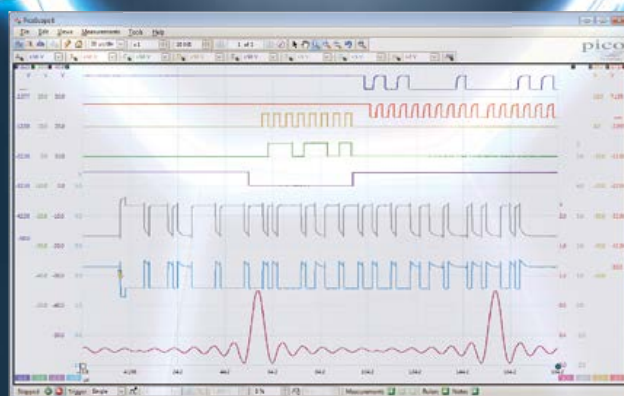

INCLUDES AUTOMATIC MEASUREMENTS,
SPECTRUM ANALYZER, SDK, ADVANCED TRIGGERS,
COLOR PERSISTENCE, SERIAL DECODING (CAN, LIN,
RS232, I²C, I²S, FLEXRAY, SPI), MASKS,
MATH CHANNELS, ALL AS STANDARD,
WITH FREE UPDATES

12 bit • 20 MHz • 80 MS/s
256 MS buffer • 14 bit AWG
www.picotech.com/PS240

High-End Amplifier for Active Speakers

Max-out your loudspeakers with this compact amplifier module



By
Alfred Rosenkränzer
(Germany)

Although active loudspeakers are more complex and more costly than passive loudspeakers, they have clear advantages in terms of audio technology and the resulting sound. To keep the complexity and cost within limits, we have developed a simple power amplifier module. Along with a suitable active crossover, you can install two, three or four of them in a speaker cabinet (depending on whether it is a two-way, three-way or four-way loudspeaker) and power them from a single supply.

Loudspeakers equipped with more than one speaker unit usually contain passive crossovers, which (in good-quality units) are made with hefty air-core coils and fairly expensive film capacitors. Their job is to divide the audio power between the woofer, midrange and tweeter units (assuming a conventional three-way loudspeaker) according to their respective frequency ranges. For stereo sound, you therefore need two power amplifiers (or output stages) in a passive system. By contrast, in an active loudspeaker each speaker unit is connected to its own amplifier and the crossover is active, which means that it is built

with transistors or opamps and is located ahead of the power amplifiers.

Pros and cons

The main drawback of active loudspeakers is the complexity: with three-way loudspeakers, you need six power amplifiers for the active version instead of the usual two. This additional circuitry makes active loudspeakers more expensive, so they are significantly less common. Even in the high-end sector, active loudspeakers are relatively rare. The complexity is more than offset by the technical and audible advantages of active loudspeakers.

To start with, the fact that each speaker unit is connected to the output of its power amplifier by a short cable is an enormous advantage. Among other things, this eliminates the need for hefty and correspondingly expensive cables, which can also be difficult to install. Eliminating the crossover network between the output stage and the speaker unit results in optimal damping of the speaker and avoids the distortion that can be caused by high currents flowing through passive components. This is particularly the case with low-cost crossovers, which are made with inexpensive ferrite-core coils and bipolar electrolytic capacitors instead of high-quality and correspondingly expensive air-core coils and film capacitors.

Another advantage of active loudspeakers is that frequency curves with steeper skirts (which means better separation of the frequency bands) can be achieved with active crossovers, and they also enable special features such as phase correction. In 2.1 speaker systems the subwoofer does not require a special speaker with two voice coils, since an active crossover can easily add the low-frequency signals from the two stereo channels to generate a signal for a channel with one power amplifier. If you search the web or the Elektor website for crossovers, you can find a lot of different crossover designs for every imaginable application. To avoid any misunderstanding, it must be said that there are passive loudspeakers available with excellent sound and active loudspeakers are not necessarily better than passive ones just because they are active. However, it's always possible to tune a passive loudspeaker by replacing the

passive crossover with an active crossover and adding suitable power amplifiers to convert it into an active loudspeaker. The difference is more than just measurable.

Power stage designs

Compared with passive loudspeakers, active loudspeakers contain a lot of electronics. Placing the active elements outside the loudspeaker cabinet would increase the cable length between the power amplifier and the speaker unit and thereby reduce the high damping factor, which is one of the advantages of an active speaker. With a three-way loudspeaker, the three thick cables required for connection to the speaker units would also create an unsightly cable jungle. There's thus no alternative: the electronics must be housed in the loudspeaker cabinet along with the speaker units, and the space available for this is usually limited.

Space is also limited in another regard: power amplifiers in the "killerwatt" range and the associated power supplies are bulky. This means that for home listening you should go for class instead of mass and avoid getting caught up in the power mania. For living-room loudspeaker applications you therefore need fairly simple, compact power amplifiers with excellent specs and relatively low to moderate power.

It is also important to be able to operate several power amplifiers from a single power supply without mutual interference. In this regard you should bear in mind that strong bass signals draw corresponding currents from the power sup-

Tech Data and Performance

Compact high-end power amplifier for active loudspeakers	
Maximum input voltage:	0.62 V for 23 W / 8 Ω
Output power (at ±25 V):	34 W / 4 Ω; 23 W / 8 Ω
Supply voltage:	±25 V for 4 Ω; ±42 V for 8 Ω
Bandwidth (1 W / 8 Ω):	16.4 Hz to 230 kHz (-3 dB)
SNR (signal to noise ratio):	>100 dB (22 Hz to 22 kHz)
SNR (1 W / 8 Ω):	>103 dB(A)
THD (distortion):	<0.1% (34 W / 4 Ω; 23 W / 8 Ω)
THD+N (with noise):	0.0023% (1 kHz; 1 W / 8 Ω)
THD+N (B = 22 kHz):	0.006% (11 W / 8 Ω)
	0.006% (1 W / 4 Ω)
	0.015% (17 W / 4 Ω)
Damping factor:	>600 (1 kHz)
Damping factor (1 W / 8 Ω):	>400 (20 kHz)
Output offset voltage:	54 mV

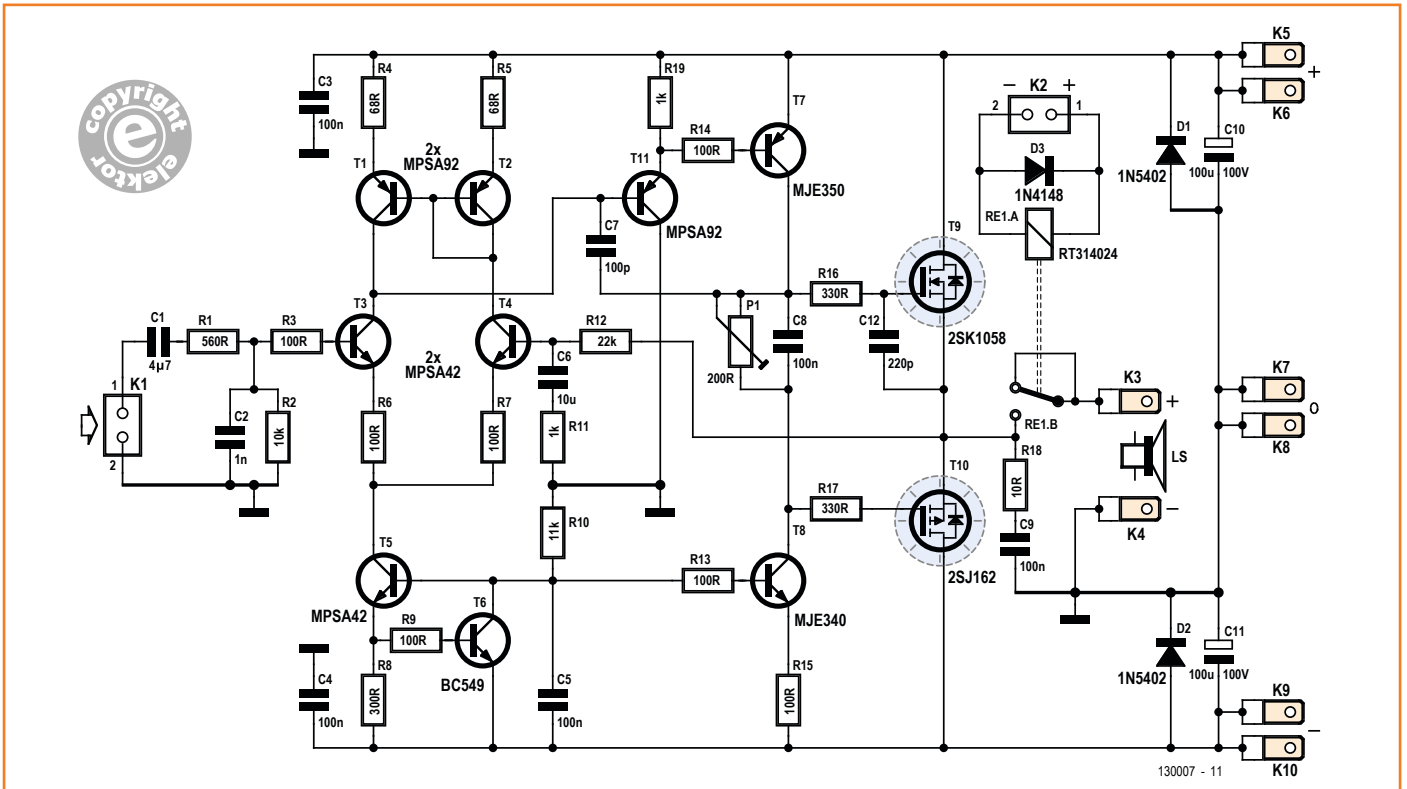

Figure 1. Schematic diagram of the complete high-end amplifier.

Figure 2. The relay control circuit is very simple.

ply, and this can easily cause voltage variations. These should not impair the midrange or tweeter channels. Otherwise you would need a separate power supply for each power amplifier, which is too much of a good thing.

In line with these requirements, the author designed a modular power amplifier that is very suitable for use in active loudspeakers. In the

circuit design the author was guided by the ideas of Douglas Self [1]. Along with other audio circuit designs, Self previously published an especially good preamplifier design in Elektor [2] that is ideal for driving active loudspeakers.

Amplifier circuit

As usual with modern power amplifiers, this amplifier is powered by a balanced supply. This eliminates the need for an output capacitor, which is particularly undesirable in active loudspeakers. The first thing you notice in the schematic diagram shown in **Figure 1** is that complementary power MOSFETs are used as output transistors. These are not the same types as those used in switch-mode power supplies or similar applications, but instead Hitachi MOSFETs with fairly low transconductance and relatively high on resistance. They have often been used in power amplifier circuits published in Elektor. There is a good reason for this: although the relatively high drain-source resistance causes higher power dissipation and therefore lower output power at a given supply voltage, you get better sound because their limiting behavior at drive levels approaching maximum output power are softer (very similar to tubes, by the way).

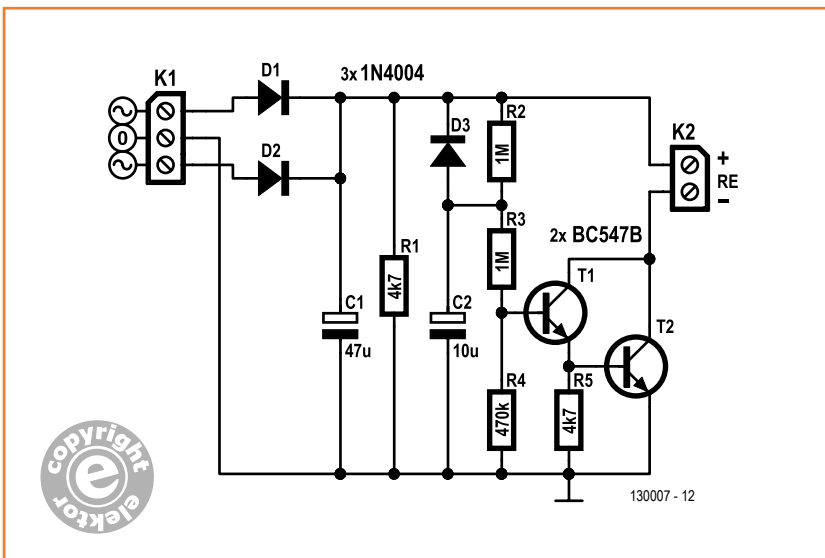

The Hitachi devices also have very low gate-source capacitance compared with MOSFETs with lower on resistance. The input capacitance of the N-type device (T9) is just 600 pF, while that of the P-type device (T10) is 900 pF. C12 largely neutralizes this difference. These low capacitance values allow relatively simple, high-impedance drive at audio frequencies with correspondingly low driver current. They also reduce the high-frequency attenuation due to resistors R16 and R17 (330 Ω). Another benefit is that driver transistors T7 and T8 do not have to supply high drive power and therefore stay reasonably cool even without heat sinks. A simple trimpot (P1) is all that is necessary for adjusting the quiescent current; there is no need for stabilization circuitry. This is because the temperature characteristics of T9 and T10 are the opposite of the temperature characteristics of bipolar transistors, so the quiescent current is self-limiting and does not rise with increasing temperature.

The driver stage works as follows. The quasi-Darlington common-emitter stage formed by T11 and T7 has a constant-current source (built around T8) in the collector lead instead of a resistor. The current through T7 and T8 is determined by the voltage across R15. This voltage is in turn determined by voltage on the collector of T6, which consists of the base-emitter voltage of T6 plus the collector-emitter voltage of T5 minus the base-emitter voltage of T8. The resulting voltage across R15 is approximately 0.67 V, which yields a current slightly less than 7 mA. The power dissipation of T7 or T8 is therefore only 170 mW with supply voltages of ± 25 V, so heat sinks are not necessary. Even at supply voltages of ± 42 V, the driver transistors do not become alarmingly hot. Now let's look at the input stage. Transistors T3 and T4 form a nearly classic differential amplifier. The collectors are connected to a current mirror consisting of T1 and T2, which is an elegant way to boost the relatively low open-loop gain of the transistors in the input stage. The emitter currents are fed through R6 and R7 from a current source built around T5 and T6, whose current is determined by the value of R8 and the base-emitter voltage of T6. The resulting current through each of T3 and T4 is about 1.1 mA. A lowpass network formed by R1 and C2 is located ahead of the base of T3, which is the non-inverting input. It blocks RFI on the input and restricts the slope of the input signal, which effectively limits the bandwidth of the amplifier. Capacitor C1 blocks

DC voltages on the input. The corner frequency of the high-pass network formed by R2 (plus R1) is about 3.5 Hz, which is low enough to allow the lower corner frequency of the amplifier (16 Hz) to be largely determined by the lowpass network formed by R11 and C6. The overall gain is determined by the ratio of R12 to R11, which is approximately 22 (corresponding to 27 dB). The current mirror and constant current source decouple the input stage from the supply voltage and thereby make the entire amplifier largely insensitive to supply voltage variations. This is what makes it possible to operate several of these power amplifiers from the same power supply, which may even be unregulated, despite their apparently simple circuitry.

Relay connection

When you switch on an amplifier, it takes a little while (like any circuit with negative feedback) to settle down to a steady operating state. An offset at the input or some other phenomenon can generate a transient at the output, which results in a clearly audible popping noise. In the case of a woofer with a large voice coil, this may only result in unpleasant noise, but for a directly connected tweeter it can be the kiss of death. This is because active loudspeakers do not have a protective capacitor in series with the tweeter to limit the transferred energy. Tweeters are sensitive because they are not designed for high continuous power, but instead for the average high-frequency audio power of typical music signals, which is rather low.

It is therefore advisable to use a time-delay relay with heavy-duty contacts to connect the speaker, instead of connecting it directly to the amplifier. Delayed relay actuation prevents any sort of switch-on pop. Ideally the speaker is also disconnected more quickly when the supply voltage drops out. This also prevents untoward events when the power is switched off. That is why relay RE1 is included in the circuit. Each power amplifier has its own relay.

It is driven by the circuit shown in **Figure 2**. Connector K1 is simply wired in parallel to the secondary of the power transformer. When the power is switched on, C1 is charged quickly and C2 is charged slowly through R2. This delays the pull-in of the relay connected to K2 by several seconds. When the power is switched off, the energy stored in the relatively small capacitor C1 is quickly used up by the relay, causing the volt-

About the Author

Alfred Rosenkränzer has been working as a design engineer for 29 years, initially in the professional television field. He has been developing and testing high-speed digital circuits and analog circuits for IC testers since the late 1990s. Audio is his personal passion.

age on the base of T1 to drop quickly because D3 provides a direct discharge path for C2. Although T2 (a BC547B) may appear to be a bit light for the job, the relay shown in Figure 1 needs only 18 mA at 25 V. The control circuit can therefore easily handle three relays of this type. The entire circuit is so simple that it can easily be built on a small piece of prototyping board and fitted in a suitable location.

Construction

A PCB layout has been designed for this nice amplifier module, with the component layout shown in **Figure 3**. If you use the PCB Prototyper [3] or your own choice of tools to make this double-sided board [4] yourself, the through-hole

plating will be missing. This means that you have to solder component leads on both sides of the board where necessary and possible. For example, there are extra holes provided for ceramic capacitors with different lead spacings. You can solder short lengths of wire on both sides in the unused holes to connect the upper and lower surfaces. You can also mount the electrolytic capacitors spaced above the board so you can solder their leads on both sides. With a ready-made board you do not have this problem, and board assembly is fairly relaxed thanks to the use of leaded components (see **Figure 4**).

Fitting T9 and T10 is a bit more complicated. They come last in the process and are mounted directly on the heat sink (see **Figure 5**). The PCB

Component List

Resistors

Default: 0.25W 1%

R1 = 560Ω

R2 = 10kΩ

R3,R6,R7,R9,R13,R14,R15 = 100Ω, .4W

R4,R5 = 68Ω

R8 = 300Ω

R10 = 11kΩ

R11,R19 = 1kΩ

R12 = 22kΩ*

R16,R17 = 330Ω

R18 = 10Ω 1W 5%

P1 = 200Ω multiterm, vertical mounting

Capacitors

C1 = 4.7μF 63V, 5/7.5mm pitch

C2 = 1nF 63V 2.5/5mm pitch

C3,C4 = 100nF 100V, X7R, 2.5/5mm pitch

C5 = 100nF 63V, MKT, 2.5/5mm pitch

C6 = 10μF 63V, MKT, 5/7.5/10/15mm pitch

C7 = 100pF 1000V, MKP, 5mm pitch

C8 = 100nF 63V MKT, 2.5/5mm pitch

C9 = 100nF 63VAC, MKT, 2.5/5mm pitch

C10,C11 = 100μF 100V, electrolytic, max. diam. 13.5mm, 5mm pitch

C12 = 220pF 1000V, 5%, MKP, 5mm pitch

Semiconductors

D1,D2 = 1N5402

D3 = 1N4148

T1,T2,T11 = MPSA92

T3,T4,T5 = MPSA42

T6 = BC549C

T7 = MJE350

T8 = MJE340

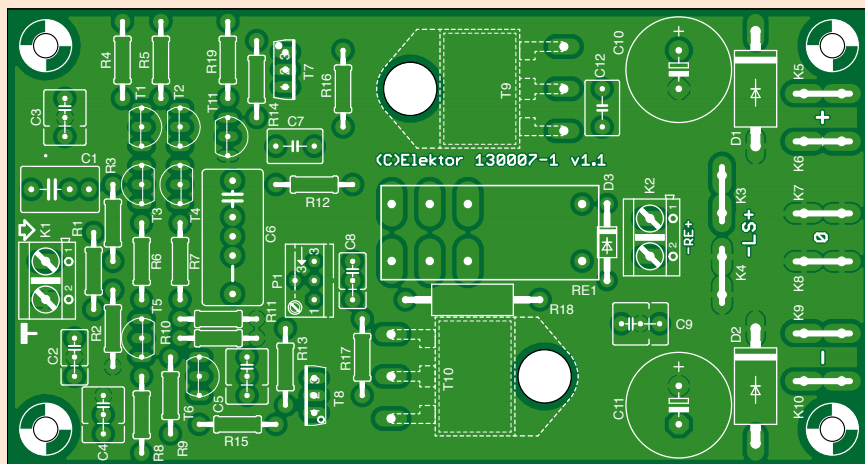

Figure 3. The PCB component layout of the high-end amplifier.

T9 = 2SK1058

T10 = 2SJ162

Miscellaneous

K1,K2 = 2-way PCB mount screw terminal block, 5mm pitch

RE1 = Relay, RT314024, PCB mount, 24V 1440 Ω, 1x c/o, 250VAC 16A

K3-K10 = Faston terminal, vertical, 0.2" pitch

T9,T10 = TO-3P style isolating washer, e.g. Kapton MT Film .15mm

Heatsink, 1.2K/W, e.g. SK 85/75 SA (Fischer Elektronik)

PCB # 130007-1 v1.1*

* see text



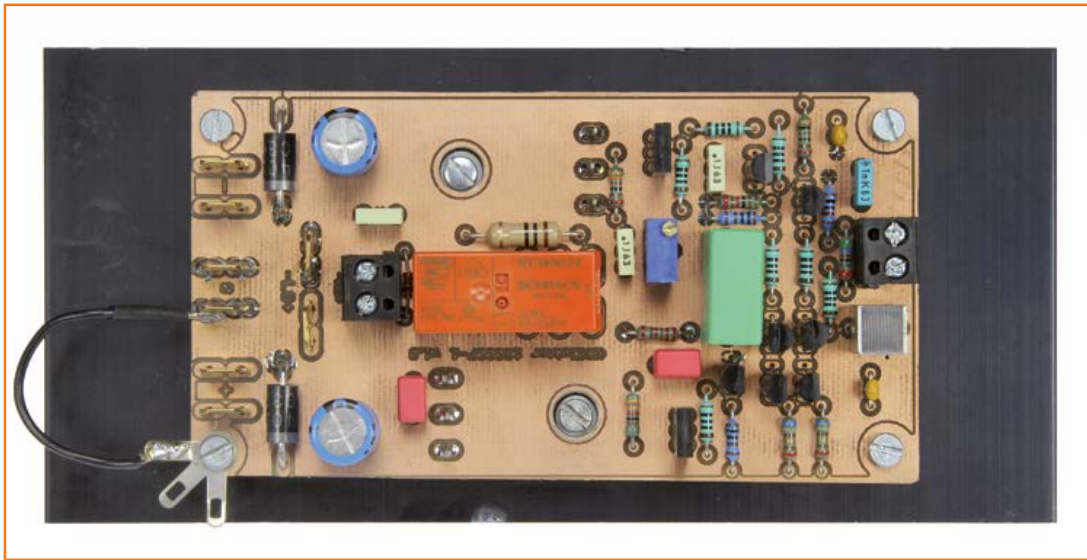

Figure 4. Top view of the fully assembled prototype circuit board.

has matching holes for the screws that secure the transistors. It can be used as template for marking the positions of the holes to be drilled in the heat sink. The board should be mounted at least 6 mm above the heat sink. This can be achieved by using 5-mm metal standoffs and split washers or suitable studs. T9 and T10 together with their insulation pads stand a bit less than 5 mm above the heat sink, so there is no direct thermal contact between them and the PCB. After drilling the holes in the heat sink, screw T9 and T10 together with their insulation pads to the heat sink with light pressure. After bending up the leads appropriately, you can slide the board over them and solder the leads on the top. After

removing the fastening screws for T9 and T10 (which is easy because the holes in the board have a diameter of 7 mm), you can then lift up board together with the transistors and solder the leads on the bottom. After this, screw the board back onto the heat sink, and don't forget the screws for T9 and T10. M3 washers also fit through the 7-mm holes.

Initial operation

The amplifier modules are designed to operate from ± 25 V supply voltages. The easiest way to provide these is to use a power transformer with two 18-V secondaries rated at 1.2 A (for 8-ohm loudspeakers). You also need a B40C2200 bridge

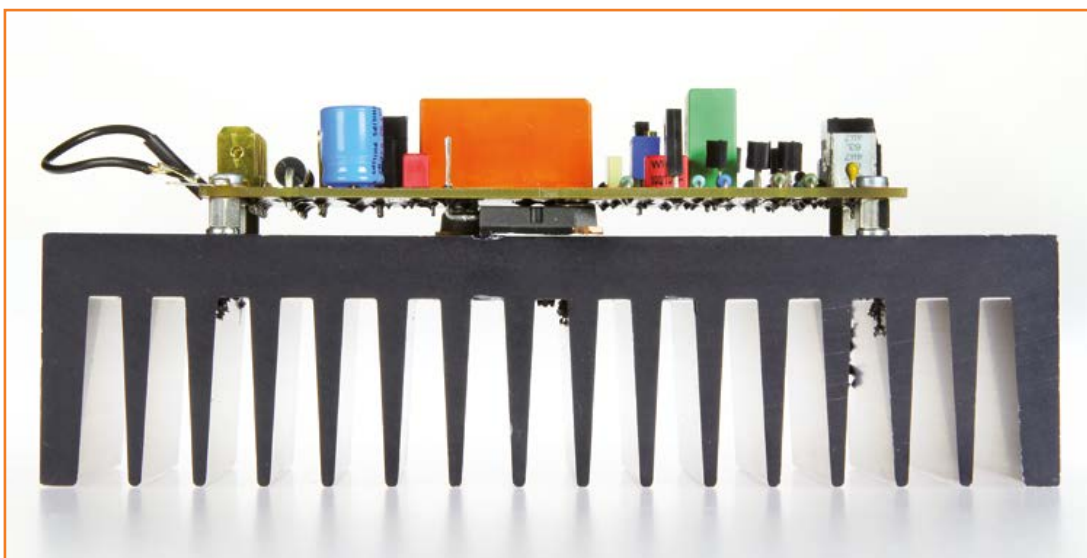
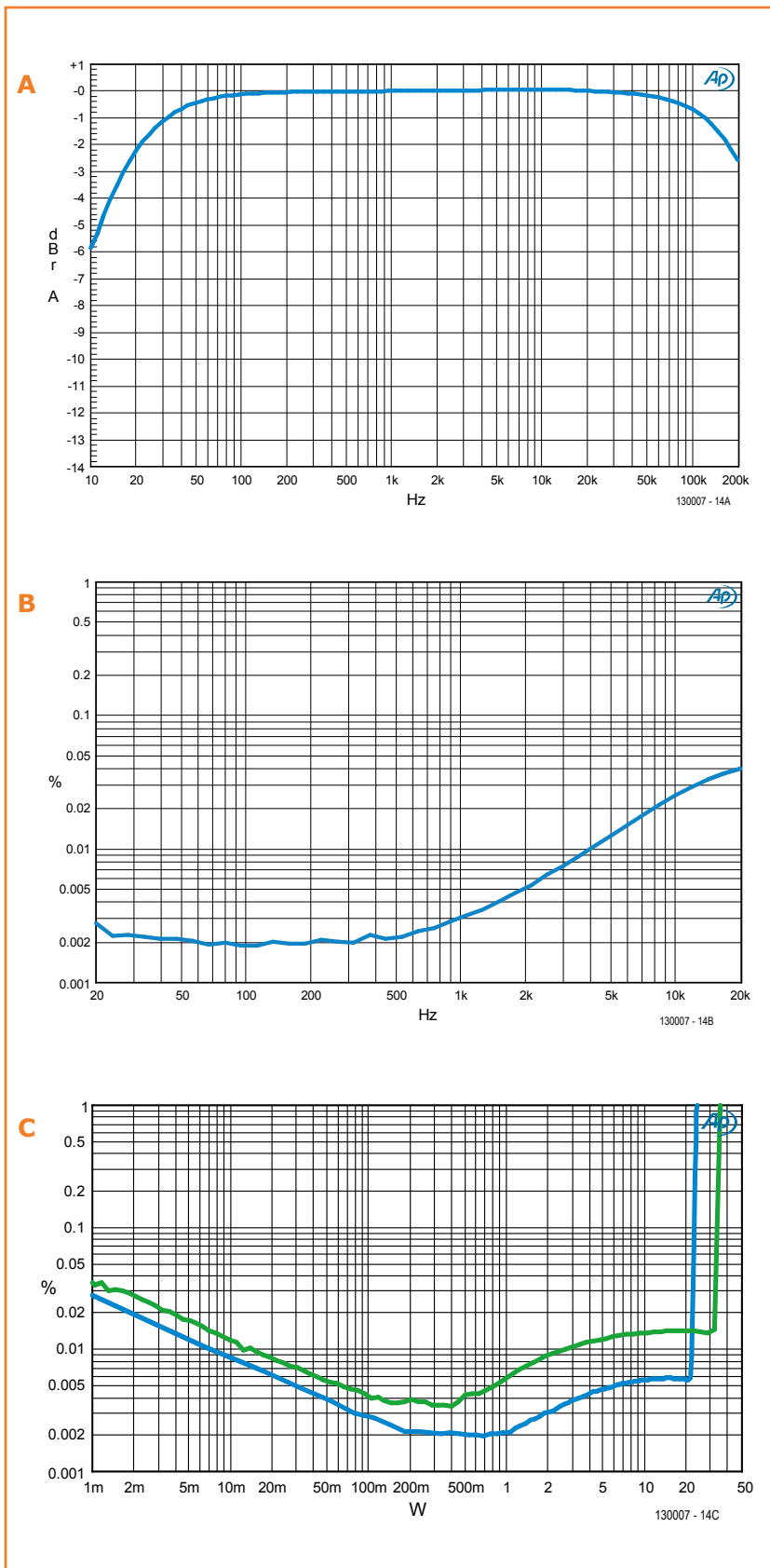

Figure 5. Here you can clearly see how the output transistors are mounted.



rectifier and two filter capacitors each rated at 4,700 μF / 35 V. That's more than enough for three high-end amplifier modules. With 4-ohm loudspeakers and correspondingly higher power, the transformer should be rated at 2 A.

Before connecting an amplifier module, you should set P1 to minimum resistance. As a precaution, it is advisable to initially connect the module to a suitable laboratory power supply or to connect a pair of high-wattage 12-V car light bulbs in series with the supply leads. That way if something goes wrong, your bench will only get bright instead of smoky. With the input shorted, set the quiescent current to 90 mA. To do this, adjust the circuit without any loudspeaker connected for a current of 99 mA in the positive supply lead (which corresponds to a current of 101 mA in the negative lead). If that works and the DC voltage on the output with the relay engaged is within the range of ± 50 mV, everything is okay and you can connect a loudspeaker and an input signal source for testing.

If instead you see a higher DC voltage on the output, you can try fitting another transistor of the same type for T3 or T4, since the DC output voltage depends on the difference between their current gains, or try adjusting the value of R2. Increasing the value reduces the voltage, and vice versa. Values in the range of 4.7 k Ω to 33 k Ω are acceptable for R2.

Curves

The high-end amplifier was extensively tested and measured by Elektor Labs. The measurements yielded the nice curves shown in **Figure 6**, which testify to the high quality of this amplifier. The top curve (A) shows the power bandwidth at 1 W into 8 Ω . It extends from 16 Hz to more than 200 kHz (-3 dB). The transfer function is considerably flatter than what you get with any loudspeaker or listening room.

The middle curve (B) shows the percentage THD+N versus frequency at 1 W into 8 Ω . The distortion and noise components are minimal at low frequencies. The distortion rises slowly above

Figure 6.

The three measurement plots show the bandwidth (A), distortion plus noise versus frequency (B), and distortion versus power (C) with 4-ohm (green) and 8-ohm (blue) loads.

Web Links

- [1] Audio Power Amplifier Design by Douglas Self: www.douglas-self.com/ampins/books/apad.htm
- [2] Preamp 2012: A DIY high-end preamplifier – www.elektor-magazine.com/110650
- [3] PCB Prototyper: www.elektor.com/PCBprototyper
- [4] Elektor website with downloads for this project: www.elektor-magazine.com/130007

1 kHz. However, 0.04% at 20 kHz is unquestionably excellent.

The two curves on the bottom chart (C) show the distortion versus power with a 4-ohm or 8-ohm load, respectively. With 8 ohms the distortion rises above 1 watt. With 4 ohms the rise starts at the same current level, and therefore at half the power level. The distortion quickly rises to more than 1% when signal limiting occurs.

Miscellaneous

If you want to get more power from the amplifier modules, you can raise the operating voltage to a maximum of 42 V. This gives you a good 60 W at 8 Ω with slightly higher distortion. With this voltage a 1 k Ω / 1 W resistor must be connected in series with each relay. A transformer with two 30 V / 2 A secondaries is a suitable choice in this case. The filter capacitors need to have a rated voltage of 63 V.

The author even drove 4-ohm speakers with ± 42 V supply voltages, yielding a good 100 W of output power. The transformer must be able to supply 3 A in this case. Even with the specified heat sink this does not cause any problems for listening to music in a home setting, since the average output power is much less than the peak power. However, this is not true in some other applications, such as a guitar amplifier. The higher peak power mainly increases the dynamic range and raises the level at which signal limiting occurs.

The circuit board has two blade connectors for each supply voltage. This simplifies daisy-chaining the supply leads. Obviously the woofer module should be the first in the chain, since it draws the most current.

(130007-1)



2-amp Maximum Power Tracking Charger Solar Power To The Max.

Using photovoltaic (PV) panels ("solar panels") is an attractive way to keep batteries charged in boats and recreational vehicles. While RVs have ample space on the roof for panels, boats, sailboats in particular have limited space. You also have

to mount the panels so that they face the sun and are not shaded partially as that badly affects their performance. The question thus becomes: How do you extract the maximum power from a PV panel? Find some answers here.



By
Anders Gustafsson
(Finland)



Photovoltaic cells can be modelled as a current source in parallel with a diode. When loaded they exhibit a V - I response like the red curve in **Figure 1**. If you calculate and plot the corresponding power, P , you quickly see that maximum power for this particular panel is delivered in the 16-volts ballpark (blue curve). This is quite typical for commercial PV panels sold as "12 volts" types. These often exhibit an open-circuit (no load; n/l) voltage of 20–25 V and peak at around 16–17 V in terms of power yield. This point is called the

Maximum Power Point or MPP for short. The activity of a circuit or system to adjust itself for MPP electronically and/or mechanically is called Maximum Point Tracking, or MPPT for short.

MPP with a trick

To safely charge a 12-V lead-acid battery, the PV voltage needs to be lowered to 12–14.4 V depending on the charge of the battery. In the past this was often done with a series regulating element, which essentially wastes power. To get

maximum power from our panel, we need to use a switching converter to lower the voltage, ideally in a loss-free manner (increasing the current) and regulate it so that we keep the panel voltage at the maximum power point. Doing so will squeeze 10-30% more charge from the same PV panel. MPP optimized chargers exist commercially—they constantly measure the output power and adjust their operation accordingly. Sadly they are quite expensive. There is an easier way, however. The MPP for most panels varies just lightly with light intensity. This design employs exactly that feature. We only need to establish our panel's MPP once—either from the manufacturer or simply by measuring—and then design our charger's behavior to match.

LT3652: battery babysitting

The design uses an LT3652 integrated circuit from Linear Technology [1]. The IC lets us build quite a sophisticated charger with a minimum of external components. You are looking at a three-stage charger capable of accepting voltages up to 32 V and charging a battery at up to 2 amps. The LT3652 fast-charges at 2 amps max. with a CC/CV characteristic up to 14.4 V, then switches to 13.5 V float charge. It also adjusts the float charge voltage, based on battery temperature. The graph in **Figure 2** shows battery voltage sampled at 30-second intervals over a period of an hour. Initially a load is connected to the battery and the voltage drops to under 12.5 volts. After about five minutes the load is removed and the battery voltage jumps to 14.4 V. At that point the charge current peaks at 1.8 A. After just over 20 minutes, the battery is fully charged, the charge current drops below 200 mA and float charging is maintained at just over 13.5 V.

The circuit

Looking at the schematic in **Figure 3**, the solar panel's + and - cables are connected to input terminal block K2. With no help, reverse voltage blocking diode D1's forward drop easily wastes approximately 1.2 watts at 2 amps hence it requires bypassing with a P-channel MOSFET, T1. When the LT3652 (IC1) charges, it pulls its $\overline{\text{CHRG}}$ output (pin 4) low, causing T1 to conduct hard and effectively short D1. Preset P1 is the part of the voltage divider that allows the MPP to be set for your panel. Adjust it so that the VIN_{REG} pin of the LT3652 sees a voltage of 2.7 V at the desired V_{MPP} . When the output voltage

Features

- For 12-V (nominal) solar panel ($V_{(n/I)}$ 20–25 V)
- 2 A max. charging current
- Efficiency 87–90%
- Adjustable for individual PV MPP voltage
- 12-V Gel / Non-Gel battery type selector
- LT3652 switching regulator especially for battery charging
- Thermal and RFI optimized PCB
- FAULT and CHARGE LED indicators
- No microcontroller
- External NTC for temperature monitoring

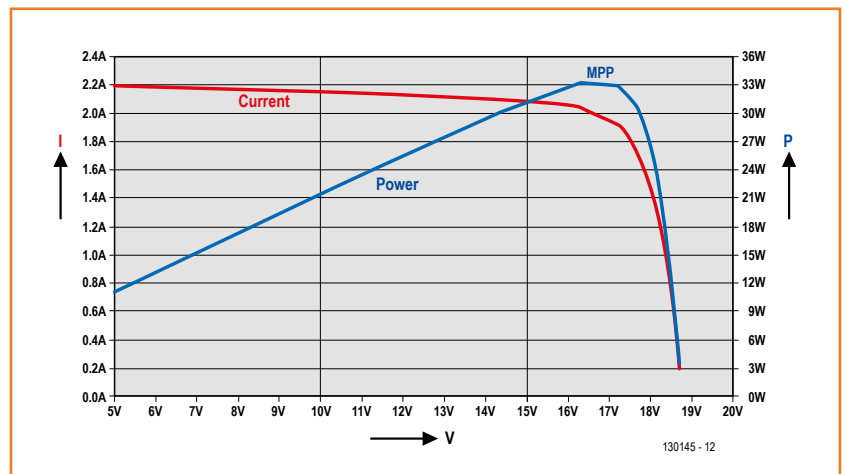

Figure 1. Graphing the voltage-current response of a solar panel is a simple method to find that "sweet spot" called MPP (maximum power point).

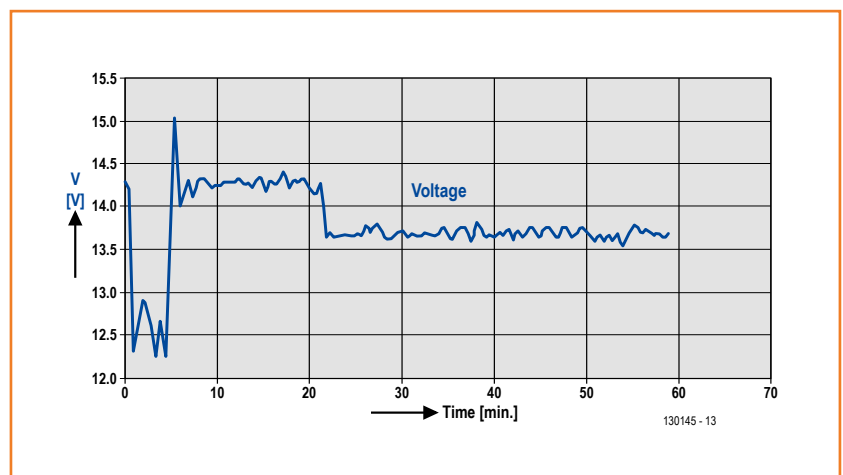
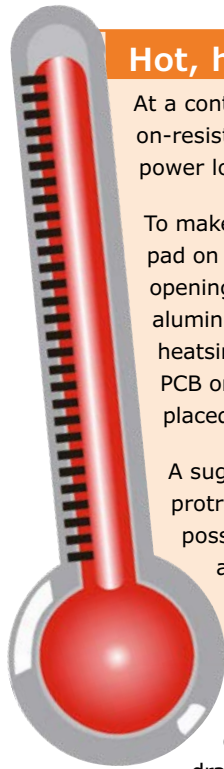

Figure 2. Voltage graph for a 12-V lead-acid RV battery recorded over a period of 60 minutes covering loading, full charging and float charging.



Hot, hot, hot

At a continuous 2 A output current the circuit and even the whole PCB gets hot. The effective on-resistance of the switch transistor in the LT3652 is 0.175Ω which causes a large part of the power loss of the circuit.

To make sure the integrated circuit has enough cooling it has an exposed pad. Vias in the pad on the PCB conduct the extra heat to the copper plane on the bottom side. Here a larger opening in the solder mask makes it possible to add extra cooling. One way is to place a small aluminum bar between PCB and the aluminum case. The case then acts as an additional heatsink for IC1. Without it we measured the temperature of IC1 at just shy of 75°C , with the PCB on our table @ room temperature. The junction of IC1 will be even hotter. If the PCB is placed inside a case at higher surrounding temperatures then more cooling is a must.

A suggested size of the aluminum bar is 5 by 10 mm. The thickness depends on the protruding through-hole components at the bottom side. Keep these lead ends as short as possible and make sure the little aluminum bar doesn't form a short circuit to connections alongside of it (especially the solder pad of TP2), and the TH components don't make contact with the aluminum case. Use thermal glue to fix the little bar to the PCB or thermal compound between it and the PCB, and glue in the corners.

drops, because too much current is drawn, the LT3652 responds by reducing its output current, thus servoing the voltage—i.e. striving to maintain it stable at V_{MPP} .

The 13.5-V float charge voltage is determined by the divider formed by R9, R10, R11, R12 and the

NTC (negative temperature resistor) connected to K1. The NTC is the variable element—the hotter it gets, the lower its resistance. For a typical lead-acid battery, the float charge varies from 14.6 V at -10°C to 13.2 V at 40°C . The NTC takes care of that, keeping the battery fully charged, without overcharging. In case no temperature com-

Sunny Considerations @ Elektor Labs

Senior Designer Ton Giesberts of Elektor Labs kind of grilled the MPP Charger in terms of design philosophy and theoretical (claimed) performance. Among his concerns are core losses in L1.

Using a fixed switching frequency of 1 MHz losses are higher with a larger core. However, efficiency measurements gave satisfactory results.

Ton used a solar panel simulator to test the circuit. There are many ways to do this—the simplest one is a beefy current source driving a large number of power diodes connected in series. The voltage across the diodes mimics that supplied by a real solar panel. A more intelligent and compact circuit was set up though with a number of 1N4148 diodes in series and the voltage across them amplified to make a series regulator to reduce the dissipated power at no-load conditions.

Usually the datasheet of a solar panel specifies the open circuit voltage, short-circuit current and the maximum power point voltage and current at 1000 W/m^2 irradiance. The n/l voltage can be set with P1. What Linear Technology call power tracking is in fact regulation of the charger's output power to maintain the user adjusted input voltage at (too) high loads. Reformulating, the output current is reduced if the solar panel is not able to deliver the necessary power. If the output power is less than the solar panel can deliver the input voltage rises above the set maximum power point level. This makes you wonder if this is really power tracking—after all, what happens to the maximum power point voltage of the panel if the irradiation is much lower (or higher) than the level specified in the datasheet?

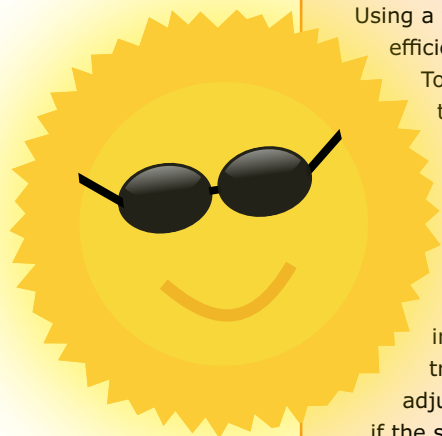

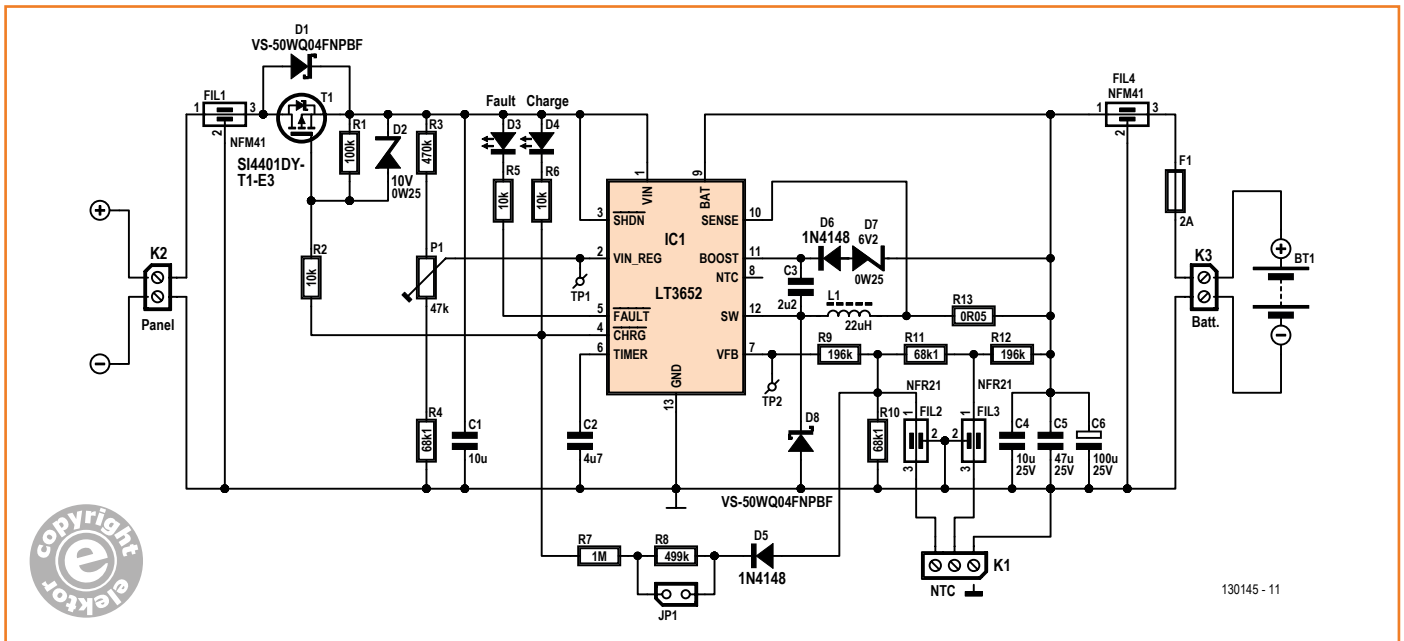

compensation is needed, simply substitute a 22-kΩ 1% fixed resistor for the NTC. For a proper V_{float} vs. temperature curve a 22-kΩ NTC with a B of 3380 is needed. Those are very hard to find, so consider using two 10-kΩ Murata type NTSD0XH103FE1B0 NTCs in series, plus a 2-kΩ 1% resistor.

Figure 3. Schematic of the Maximum Power Point Charger. At the heart of the circuit sits an LT3652 switcher IC from Linear Technology. Note the ferrite beads (FILx) at critical points in the circuit—they serve to keep RFI to a minimum.

Figure 4. The circuit board designed by Elektor Labs takes into account compactness, high current, RFI you can expect from an SMPSU, and thermal issues. Properly built and encased the charger should emit a minimum of radio interference.

Component List

Resistors

R1 = 100kΩ 5% 0.125W, SMD 0805
 R2,R5,R6 = 10kΩ 5% 0.125W, SMD 0805
 R3 = 470 kΩ, 1% 0.1W, SMD 0805
 R4,R10,R11 = 68.1kΩ 1%, 0.125W, SMD 0805
 R7 = 1MΩ 5% 0.125W, SMD 0805
 R8 = 499kΩ, 1%, 0.125W, SMD 0805
 R9,R12 = 196kΩ 1% 0.125W, SMD 0805
 R13 = 0.05Ω 1%, 1W, SMD 1206
 P1 = 47kΩ 20% 0.15W, trimpot, top adjust

Capacitors

C1 = 10µF 50V, +80%/−20%, SMD 1210, Y5V
 C2 = 4.7µF 25V, 10%, SMD 1210, X7R
 C3 = 2.2µF 25V, 10%, SMD 0603, X5R
 C4 = 10µF 25V, 10%, SMD 1206, X5R
 C5 = 47µF 25V 20%, SMD 2220, X7R
 C6 = 100µF 25V 20%, Radial Can SMD

Inductor/Filters

FIL1,FIL4 = NFM41PC204F1H3L (Murata)
 FIL2,FIL3 = NFR21GD4702202L (Murata)
 L1 = 22µH 11A, 20%, 14.6mΩ (Würth Elektronik 74435572200)

Semiconductors

D1,D8 = VS-50WQ04FNPBF, SMD D-PAK

D2 = BZX84-B10,215, SMD SOT-23

D3 = LED, red, 3mm, through hole

D4 = LED, green, 3mm, through hole

D5,D6 = 1N4148, SMD SOD-123F

D7 = BZX84-B6V2, SMD SOT-23

IC1 = LT3652EMSE#PBF, SMD 12MSOP

T1 = SI4401DY-T1-E3, SMD SO-8

Miscellaneous

F1 = 2A antisurge (T), 5x20mm, with PCB mount holder and cap JP1 = 2-pin pinheader, 0.1" pitch
 JP1 = jumper, 0.1"
 K1 = 3-way PCB screw terminal block, 5mm pitch
 K2,K3 = 2-way PCB terminal block, 5mm pitch
 TP1,TP2 = solder pin
 Case: Teko 2/A.1, aluminum, size 57.5x72x28mm
 PCB # 130145-1 v1.1 [1]

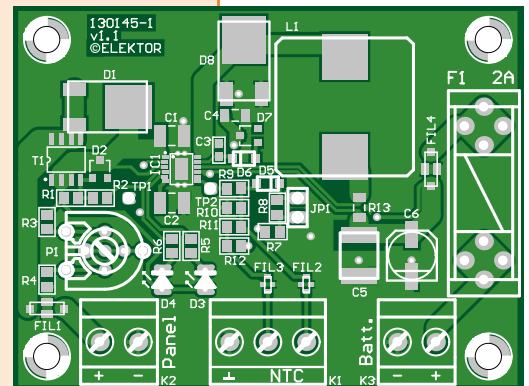



Figure 5. Less than perfect in appearance, sure, but the author's own charger does a good job on his sailboat.

Table 1. Measured Performance @ E-Labs (with 22 kΩ resistor for NTC)

$V_{in}[V]$	$I_{in}[A]$	$V_{out}[V]$	$I_{out}[A]$	$P_{in}[W]$	$P_{out}[W]$	Efficiency (%)
16	1.004	9.8	1.466	16.064	14.469	90.07
16	1.004	10.77	1.35	16.064	14.54	90.51
16	1.002	11.60	1.25	16.032	14.5	90.44
16.97	0.903	13.95	1.00	15.323	13.95	91.03
18.3	0.64	13.97	0.75	11.712	10.478	89.46
18.95	0.4	13.99	0.47	7.58	6.617	87.30

When the LT3652 is charging and assuming jumper JP1 is fitted, R10 is paralleled with R7, effectively setting the voltage at 14.4V. With jumper JP1 not in place, the maximum charge voltage is 14.1 V as required by some batteries, mostly of the gel variety. Check the manufacturer's specifications.

The LT3652 has a fixed switching frequency of 1 MHz, making it an extremely effective jamming transmitter. The prototype managed to block all VHF FM broadcast reception in our boat! The finished charger is much quieter because of a better PCB, shielding and Murata RFI filters (FILx) on the input, output and NTC connections.

The PCB

Since this is a switcher, PCB layout is critical. The PCB design produced by Elektor Labs [2] (Figure 4) follows the guidelines in the LT3652 datasheet and also uses "fat" traces whenever necessary. The LT3652 has an exposed pad that needs to be soldered to the PCB, and that area is connected to the reverse side of the PCB for cooling, via a cluster of vias, see also the considerations in the inset "Hot, hot". The PCB has

to be mounted in such a way that its underside is in thermal contact with the metal enclosure. In the author's charger (Figure 5) the PCB is mounted on plastic standoffs, with an aluminum slab directly underneath the PCB. Note that the LT3652 has a built in thermometer that will lower the charge current in case of overheating. Need more power? Just add panels, have one charger per panel and parallel the outputs!

Notes on efficiency

Losses in this circuit are caused by several factors. Some are within our control; others, not—or not easily. We have the loss caused by R_{Dson} in T1—in this case, around 40 mW, little we can do about that. Likewise, the forward drop of the LT3652 and the loss in D8—both are difficult to control let alone avoid.

Happily there are two factors well within our tech governance. One is the resistive losses in L1—the inductor chosen here is good for a whopping 11 amps and that might seem overkill. A much smaller 2.1-A inductor would work just fine, but then it has a series resistance of 170 mΩ—compare that to the 14.6 mΩ of the 11-A inductor. So the smaller inductor, if chosen, would dissipate close to 0.7 watts at 2 amps where the larger one only dissipates 46 mW. The other factor is resistive losses in C4, C5, C6—yes, the output capacitor(s). They should be selected for high current-carrying capacity and low ESR.

Happy Sailing — RV'ing — Chilling — Outdoor'ing!
(130145)

Other measurements

Jumper (JP1) not fitted:

- charging stops at 14 V (14.35 V if PCB hot);
- Charging resumes when voltage drops to 13.9 V;
- After switch-on, with pure resistive load on output: 2 V at output (0.3 A) until voltage rises to 9.5 V (0.28 A at 9.0 V), then voltage and current rise to 9.8 V; 1.44 A.

Jumper JP1 fitted:

- charging stops at 14.2 V (14.56 V if PCB hot);
- charging resumes when voltage drops to 13.9 V;
- After switch-on, with pure resistive load on output: 2 V at output (0.3 A) until voltage rises to 9.7 V (0.28 A at 8.6 V), then voltage and current rise to 9.88 V; 1.43 A.

Web Links

- [1] www.linear.com/product/LT3652
- [2] www.elektor-magazine.com/130145

HERE I FIND
EVERYTHING - FROM
OFFICE EQUIPMENT
TO COMPONENT
PARTS

ALL ITEMS
IN SMALL
QUANTITIES AT
BEST PRICES!

Everything I need for my project!

www.reichelt.com

- ✓ more than 45,000 products in stock
- ✓ no surcharge for quantities below minimum
- ✓ fast international delivery service
- ✓ insured dispatch
- ✓ 97 % customer satisfaction

(Source: www.shopauskunft.de)



www.reichelt.com

**DISCOVER
NOW**



Website content and customer service
is in German and English.

UART Module for ECC

Interchangeable interfaces using the Embedded Communications Connector

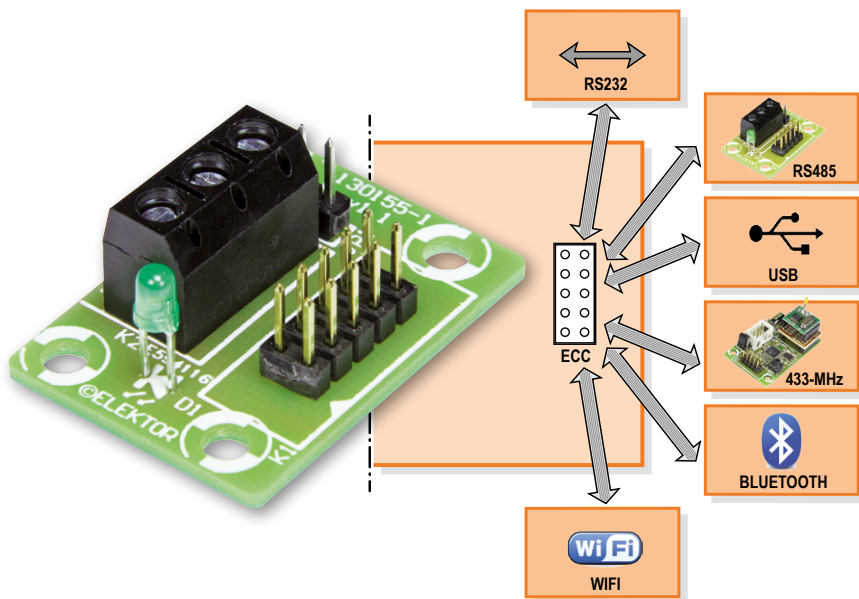

Very often a project will demand an external interface such as RS-232, USB or Bluetooth, and using a small ready-made module can reduce development time and gain flexibility. The use of a standard header to carry serial data to and from the module means that they can be interchangeable: in this article we propose a connector specification and present our first module, designed for robust RS-485 communication. More modules will be presented in the future.

By **Jens Nickel**
(Elektor Germany)

When designing an evaluation or prototyping board for a microcontroller consideration must be given to the number and type of peripherals that will be included. If too few are provided, some developers might find functions that they need are missing; if too many, the board becomes large and expensive. A good solution is to design a board that includes only the essential features (perhaps a couple of LEDs for testing), but also to provide expansion connectors that are wired to the microcontroller's interfaces: SPI, I²C and UART for example. Then the developer can plug in whatever expansion boards he needs for his application.

Of course it would be possible to design a range of expansion boards for each microcontroller board. But a better idea is to adopt an existing specification for the expansion connector: then it is just a question of ensuring that the pin in each position matches the original in terms of function and electrical characteristics (signal levels, current limits and so on). As a result developers will be

able to choose from a wide range of expansion boards already available on the market. A popular example of this philosophy is the Arduino system. There is a wide range of microcontroller boards from various manufacturers with connectors arranged in the same pattern as the Arduino. A so-called 'shield' can be plugged into any of these boards, and around a hundred different shields are available.

When prototyping it is often helpful to be able to connect an expansion board to the motherboard via a ribbon cable rather than plugging it in directly. This is particularly the case for expansion boards that include user interface elements such as LEDs, buttons or displays, but also if the board carries an external physical interface, such as USB, Ethernet or RS-485. A few months ago we described the GnuBlin Embedded Extension Connector (EEC), which carries SPI, I²C, analog and digital signals on a 14-way DIP (2x7) header [1]. Standardizing on this connector meant that the various expansion boards [2]

designed for the GnuBLIN Elektor Linux Board could also be used with the Xmega web server described recently [3]. More microcontroller boards like this will appear in the future.

Headers for RX and TX

The ECC lacks pins carrying UART signals. An asynchronous serial interface, using just two data lines for bits to be transmitted and received (there is no clock signal) is popular for communications between boards and between devices. It is relatively robust, does not impose any special requirements on the circuit board layout or on the connectors used, and is simple to use in software. Every microcontroller manufacturer provides libraries to drive the serial interface peripherals built in to their microcontrollers, and often complete ready-made examples are available. Many programming languages, such as C for the Arduino or BASCOM, include special commands to sending and receiving characters using the UART.

What's more, there are many peripheral devices available that accept UART-style communications on one side and provide communications in a different format on the other. Examples include RS-485 and RS-232 drivers and popular USB-to-serial converter chips such as the FT232 series. Devices and modules providing Bluetooth, WLAN and other interfaces are also available on the market. By putting these devices on an expansion board with a standardized connector carrying the UART signals we open up the possibility of using

any of them with any compatible microcontroller development board.

Power supply

Figure 1 shows our proposal for such a connector specification, which we have dubbed the 'Embedded Communication Connector', or ECC. The microcontroller board and the expansion board each carry a two-by-five connector, and they can be connected using a ribbon cable. For serial communication we require as a minimum the RX (receive) and TX (transmit) signals, plus ground. Two further pins, called GPIOA and GPIOB, carry digital signals that can be used for controlling the peripheral module. These can be used, for example, for flow control in an RS-232 application or to control half-duplex operation in an RS-485 application. So that expansion boards can be powered from the mother board we add a power supply pin (VCON, for $V_{CONTROLLER}$) at 5 V. Although the trend in electronics is towards 3.3 V operation rather than 5 V operation, we have opted here for 5 V power and 5 V compatibility for the data and control signals: note that this is different from the ECC/GnuBLIN connector mentioned above. The case of USB demonstrates that this voltage is still in wide use in communications, and many RS-232 and RS-485 driver devices require a 5 V supply.

In the opposite corner of the connector is the VIN (V_{IN}) pin, through which the microcontroller board can be powered from a daughter board. This is useful for 'gateways', expansion boards

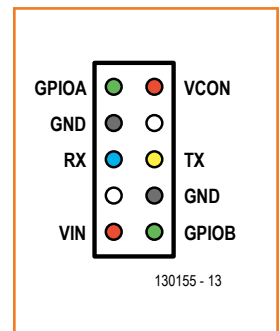
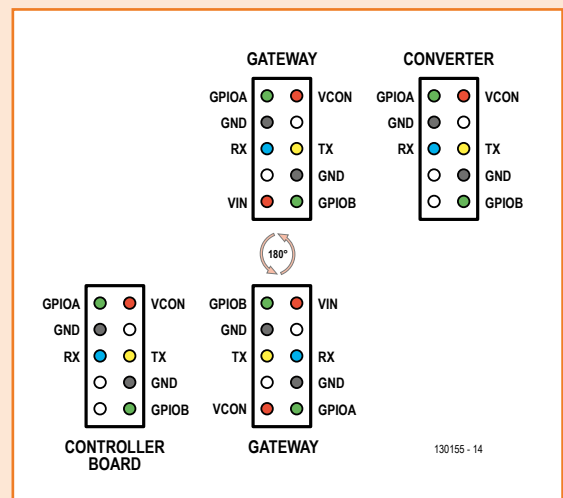

Figure 1. The ECC carries the RX and TX signals, as well as two digital signals that can be used to control the interface module.

Inter-Microcontroller Communication

A gateway, such as the bridge between UART signals and a 433 MHz (LPR band) wireless link that will be described in the next issue, differs from a 'dumb' converter in that it contains its own microcontroller and software. The ECC makes it possible to connect a peripheral module, such as our RS-485 driver, to such a gateway. And likewise the gateway can be connected to a microcontroller board as a peripheral. The gateway can supply a peripheral module with power over the VCON pin, or it can be supplied with power from a microcontroller board over the VIN pin. If a ribbon cable is used to connect the boards the connector on the gateway must simply be rotated by 180 degrees, which will connect the VCON pin on the microcontroller board to the VIN pin on the gateway. Conveniently this also exchanges the RX and TX signals, so that the microcontroller on the motherboard and the gateway can communicate with one another.



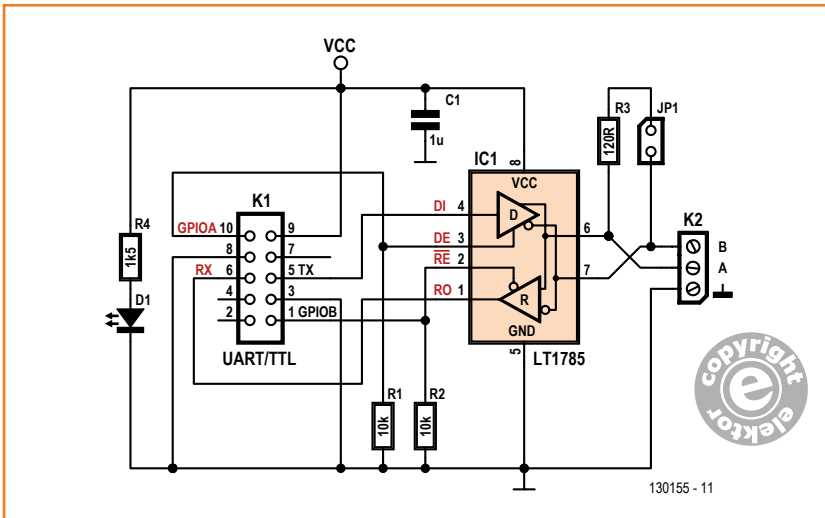

Figure 2. The circuit of the first ECC module is built around the familiar LT1785 RS-485 driver.

that themselves include a microcontroller: more on this in the text box. Finally there are two uncommitted pins that can be used for any purpose required by a given project.

RS-485 driver

The first expansion board we have developed using the ECC is a simple RS-485 driver. This allows a microcontroller board to be equipped with an RS-485 interface that can be used to provide reliable communications over long distances. RS-485 is ideal for creating bus structures, where multiple bus participants are connected to the same pair of wires A and B that carry messages.

In such a structure only one bus participant is allowed to 'speak' at any time.

The circuit of the module is shown in **Figure 2**. At its heart is a Linear Technology LT1785 [4], which has already been used successfully on the ElektorBus boards [5]. Its job is to convert the TTL-level UART signal TX to an RS-485-compatible differential signal on the A-B signal pair; and to output bits received on the bus on the RO pin at TTL levels. The \overline{RE} and DE inputs to the device, both fitted with pull-down resistors, control half-duplex communication. A high level on DE means that bits to be transmitted will be driven onto the bus lines, and a low level on \overline{RE} means that data can be received. Before transmitting data, therefore, the \overline{RE} and DE inputs should both be taken High; after the message has been sent the \overline{RE} and DE inputs should be taken Low again so that the device can listen to what another bus participant has to say. In our circuit we have connected GPIOA on the ECC header to DE and GPIOB to \overline{RE} . Jumper JP1 allows resistor R3, nominally 120 Ω , to be connected across the RS-485 bus to terminate it. The jumper should be fitted on the first and on the last device in the RS-485 chain. Screw terminals are provided for the A and B lines. As discussed in an ElektorBus article [6], it is essential to have a common ground connection to prevent communications errors. LED D1 allows you to check that the expansion board has been correctly connected.

To make the module as compact as possible, the Elektor-designed printed circuit board uses mainly surface-mount assembly (SMA) components on the underside of the board. Populating the board should not present great difficulty, but in any case ready-assembled boards are available from the Elektor Store [7].

Microcontroller board

Gradually we will build up a small menagerie of ECC-compatible expansion boards. At the moment we are working on a 433-MHz (LPR band) gateway in the Elektor Labs that outputs characters received on the serial port over the air and vice versa. Further modules are planned.

So far we are missing a widely-available microcontroller board that comes with an ECC. Since there are, as we mentioned earlier, so many Arduino boards on the market, why not combine the best of both worlds? In the Elektor Labs we

Component List

Resistors (SMD 0805, .125W)
R1,R2 = 10k Ω 5%
R3 = 120 Ω 5%
R4 = 1.5k Ω 5%

Capacitors (SMD 0805)
C1 = 1 μ F 10V 10%, X7R

Semiconductors
D1 = LED, green, 3mm, low current, through hole
IC1 = LT1785CS8#PBF (SO-8)

Miscellaneous
K1 = 10-pin (2x5) pinheader, 0.1" pitch
K2 = 3-way PCB mount screw terminal block, 0.2" pitch
JP1 = 2-pin pinheader with jumper, 0.1" pitch
PCB # 130155-1 v1.2
or
PCB, ready assembled and tested, Elektor Store # 130155-91

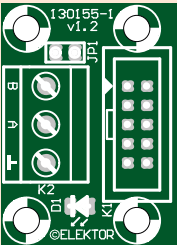
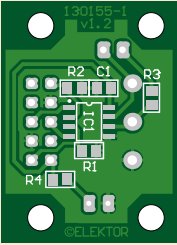
have created a shield that allows prototyping and experimentation with Arduino-compatible micro-controller boards, whether operating at 3.3 V or 5 V. The shield includes two LEDs, two buttons, a potentiometer, an EEC header and of course an ECC header.

We have not yet made the printed circuit board (**Figure 3**) for this design, but it is easy enough to make a shield for the Arduino Uno using a piece of prototyping board. Headers are fitted to the underside of the board to match the positions of the sockets on the Arduino. Note, however, that the spacing between the top left socket and the top right socket is not exactly a multiple of the 0.1 inch grid, but we do not require digital signals 8 to 13. **Figure 4** shows how the various components (the two-by-five header, the two buttons and the potentiometer) should be connected to the Arduino's pins on the shield.

Demonstration software

For a simple test we can use an Arduino Uno and our prototype shield. No programming hardware is needed if we use the Arduino development environment [8] and its pre-programmed bootloader: we just connect the Arduino board to the PC using USB and download our code into the microcontroller. The USB connection also provides power. The RS-485 expansion board is connected to the ECC header on the shield using a ten-way ribbon cable: the Arduino Uno is now equipped with an RS-485 interface. To test the interface properly we need another device on the RS-485 bus: for this we can use the *Elektor* USB-to-RS-485 converter [5] connected to a PC. The three wires of the ECC RS-485 module (the signal wires A and B plus ground) are connected to the corresponding pins on the converter: the whole arrangement is shown in **Figure 5**. We can now send characters from the Arduino to the PC: they can be viewed using, for example, the serial monitor in the Arduino development environment.

To make things easy for our initial testing we will use the 'AnalogReadSerial' example program supplied with the Arduino development environment. This program continuously samples the voltage level on analog pin A0 and sends out readings on the serial port. However, the potentiometer in our circuit is connected to pin A3, not A0. Furthermore, we need to make sure that the DE input to the RS-485 driver is held high; and

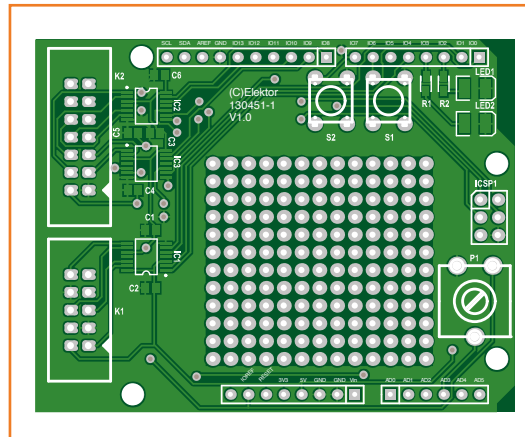

Figure 3. In the near future we will publish an experimental shield for Arduino-compatible boards. Of course it will include an ECC header.

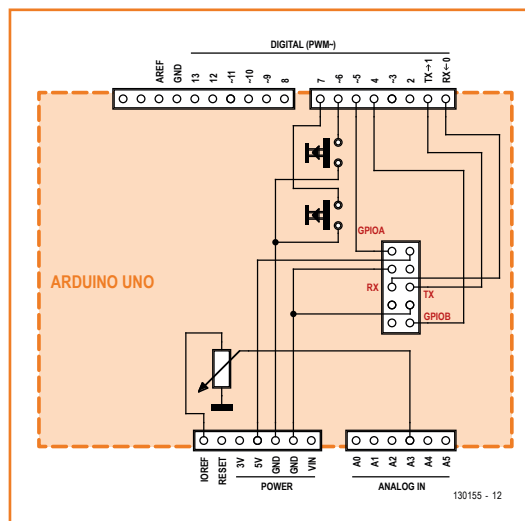
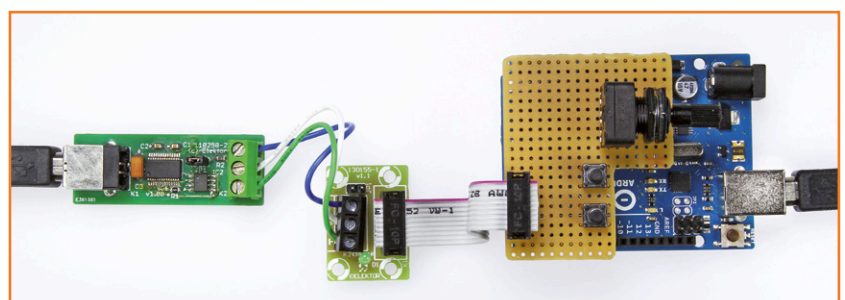

Figure 4. For our first experiments we constructed a simple shield for the Arduino Uno.

because we do not want to receive data while transmitting, we need to keep the /RE input high as well. These two inputs are connected to the GPIOA and GPIOB pins on the ECC, and these connections are in turn taken to digital pins 5 and 4 on the Arduino. The necessary changes are brought together in **Listing 1**, and the code is of course included in the software download available from the Elektor website [7].

Figure 5. The Arduino Uno (plus prototype shield) equipped with an RS-485 interface. To test the arrangement we connect it to a PC via our USB-to-RS-485 converter.



When uploading the program to the Arduino it is necessary to disconnect the RS-485 board as the bootloader uses the microcontroller's UART during the process. When programming is complete the RS-485 board can be connected to the Arduino: don't forget to change the COM port setting in the development environment to match the one used by the USB-to-RS-485 converter. In the serial monitor you should now see numbers varying from 0 to 1023 as you adjust the potentiometer: see **Figure 6**.

Control and measurement

We have also developed some slightly more refined software using the Embedded Firmware Library (EFL), and have made the source code available in the download [7]. For this EFL project we have integrated all the files directly and so there is no need to download the entire EFL codebase and it is easier to gain an overview of the project. A click on the file ArduinoRS485.atstn opens the project in Atmel Studio 6.

We encountered the microcontroller file (ControllerEFL.c, in the Hardware directory) for the ATmega328 used on the Arduino Uno board in the first EFL article [9]. We have developed a new board file BoardEFL.c for the 'bare' Arduino board.

The file is very short: on the Arduino board itself we only have the expansion connectors and an LED. When the board is initialized the relevant pins are added to the block and board pin tables, and the pin for the LED block (just one in this case) is configured as an output.

The code in the extension file (Extension.c) is more interesting, as it represents the wiring on the shield and our small RS-485 interface board. The code initializes the digital inputs for the buttons, the ADC to read the potentiometer voltage, and the UART interface. Of course, the code is arranged to refer to pins on the expansion header rather than directly to the port pins on the microcontroller. This means that we can reuse the code for our prototype shield without modification if we replace the microcontroller board with a different Arduino-compatible microcontroller board. In the higher software layers we deal with the various peripheral blocks only via the libraries UARTInterfaceEFL, ADCSimpleEFL and LEDButtonEFL. The BlockProtocolEFL library, extensively described in a previous article [10], uses a simple ASCII-based protocol to control the Arduino from the PC. It listens for commands sent from a terminal emulator program running on the PC, and then initiates the appropriate action. The

Listing 1: AnalogReadSerial over RS-485 (excerpt)

```
// the setup routine runs once when you press reset:
void setup() {
  // initialize serial communication at 9600 bits per second:
  Serial.begin(9600);

  pinMode(5, OUTPUT);      // set the pin 5 = ECC-GPIOA = RS485-DE to Output
  pinMode(4, OUTPUT);      // set the pin 4 = ECC-GPIOB = RS485-/RE to Output
  digitalWrite(5, HIGH);   // set the pin 5 = ECC-GPIOA = RS485-DE to HIGH-level
  digitalWrite(4, HIGH);   // set the pin 4 = ECC-GPIOB = RS485-/RE to HIGH-level
}

// the loop routine runs over and over again forever:
void loop() {
  // read the input on analog pin 3:
  int sensorValue = analogRead(A3);
  // print out the value you read:
  Serial.println(sensorValue);
  delay(1);               // delay in between reads for stability
}
```

library makes implementing this very straightforward and so the main program is, as usual, very short and easy to follow. And, of course, it is independent of the underlying hardware. For test purposes we have arranged the code to toggle the state of the LED when one of the buttons is pressed.

The compiled EFL program has to be uploaded to the Arduino using a programmer in conjunction with Atmel Studio 6: the bootloader mentioned above will be overwritten by the EFL code, but it can be rewritten using the Arduino development environment and a programmer.

Next, set up the terminal emulator program as shown in **Figure 7**. The commands L 0 0 + <Enter> and L 0 0 - <Enter> will turn the LED on the Arduino board on and off. The command B 0 0 ? <Enter> interrogates the status of the first button on the shield and the command A 0 0 # <Enter> reads a value from the ADC (which corresponds to the potentiometer position). Pressing <Enter> on its own repeats the last command. The program can easily be used with any shield that takes analog readings and switches digital outputs. Thanks to the RS-485 interface the microcontroller board can easily be located 100 feet (30 m) or more away from the PC.

(130155)

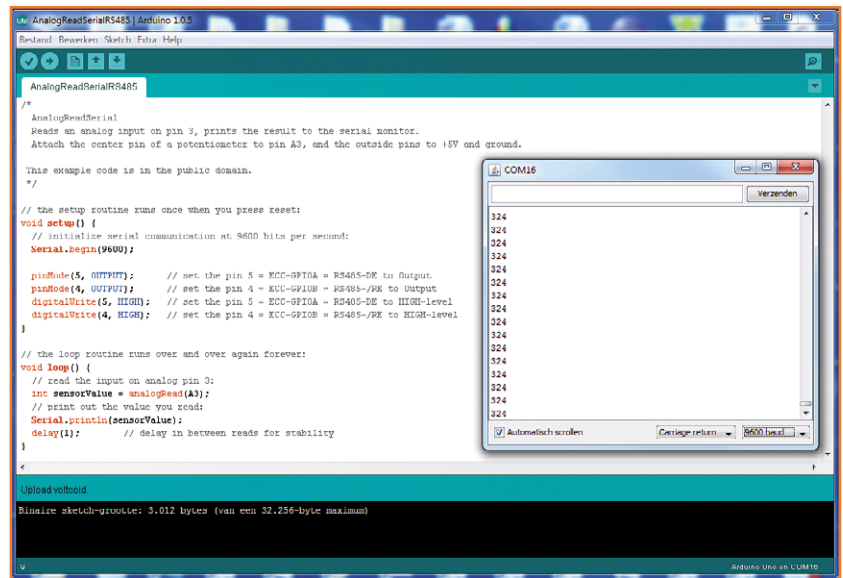
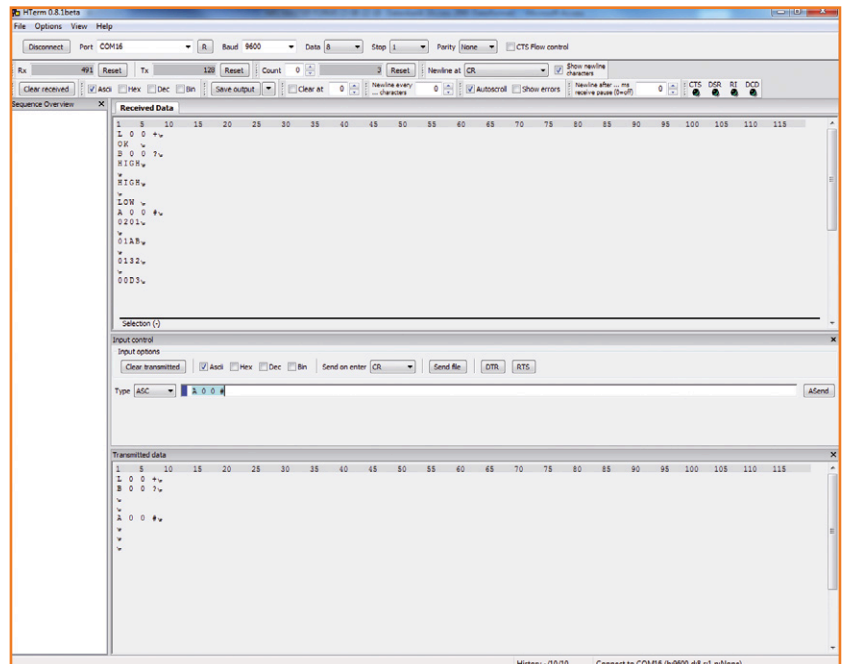

Figure 6. All we need for our first demonstration is to modify the 'AnalogReadSerial' Arduino example slightly.

Figure 7. A terminal emulator program such as HTerm is all that is needed to obtain readings over the RS-485 bus using the 'BlockProtocol'.



Web Links

- [1] www.elektor-magazine.com/130212
- [2] www.elektor.com/gnublin
- [3] www.elektor-magazine.com/120126
- [4] www.linear.com/product/LT1785
- [5] www.elektor-magazine.com/110258
- [6] www.elektor-magazine.com/110225
- [7] www.elektor-magazine.com/130155
- [8] www.arduino.cc
- [9] www.elektor-magazine.com/120668
- [10] www.elektor-magazine.com/130154

Mini Modules for Breadboarding

PSU, LED, pushbutton, PIC or LCD, etc.

By Jennifer Aubinais
(France) [1]

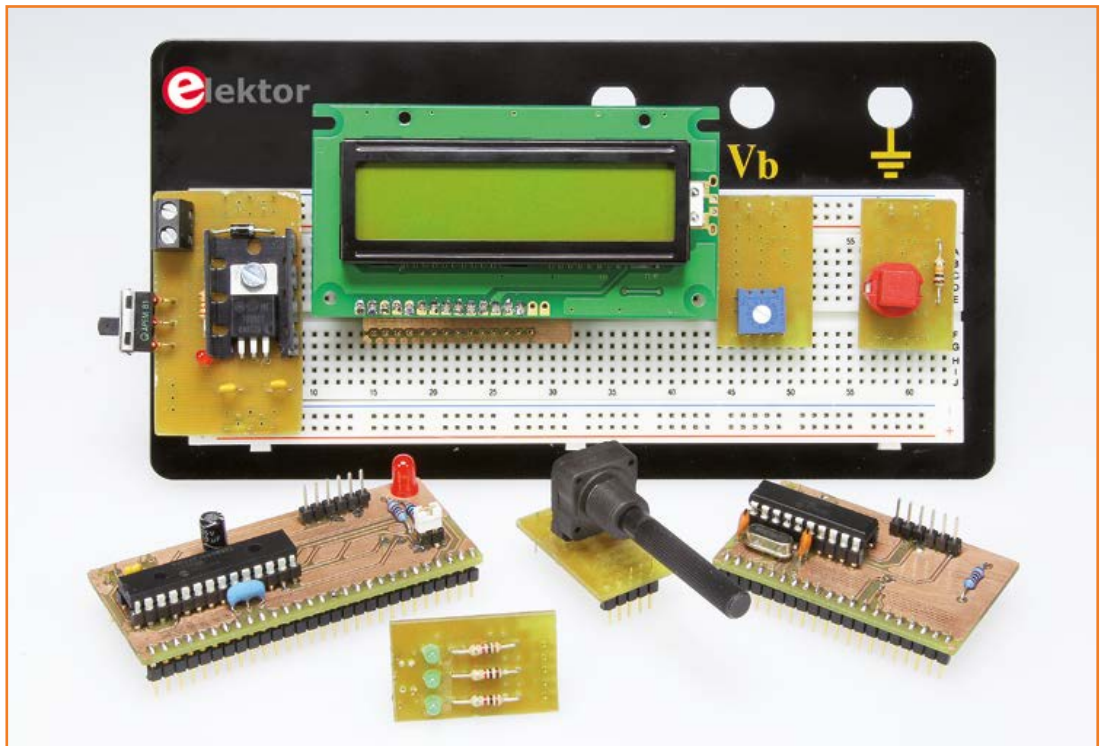

I like using solderless breadboards, except when you have to build the same circuit element for the umpteenth time—for example, a 5-V supply complete with decoupling, or a drop-in microcontroller. So I've made these into modules that can be plugged directly into the board. Now I only need nine wires to build a PIC voltmeter and LCD display!

A power supply block using a time-honored 78xx with its capacitors and LED indicators is something that's always cropping up in our experiments. What a relief to have at hand a ready-made block you only have to plug in. And all those components with pins too fat for the holes that risk damaging the board, like push-buttons; or the potentiometer with flying leads that's going to dangle miserably beside the prototype. So solder them once and for all onto the PCB of a purpose-designed mini module, to which you will

fit pins on the required spacing.

Let's talk about this pin spacing! You doubtless thought it would be standard for all boards? So did we. Well, get that idea right out of your head! While preparing these modules and carrying out tests with various boards, we were surprised to find that they exhibited troublesome differences, depending on where they came from. We'll come back to this later when we discuss building the modules, but for the moment let's start with some introductions.

I'm suggesting five modules here, just to start off with, but there will undoubtedly be others coming soon. Above all, the interest *you* show in these tools intended to make experimentation easier will determine where we go after this article. Here's the most indispensable module.

Power module (single-sided)

Do you need 5, 6, 8, 9, 10, 12 volts or more on your breadboard? Choose the right plug-in module (**Figure 1**), fitted with a 78xx regulator in a TO-220 package of the appropriate voltage. It already has the two 100 nF capacitors for stability plus a 1N4004 diode to avoid polarity reversal. On the prototype, I added a switch and an LED indicator so I can tell when it's on.

This module doesn't have a reservoir capacitor (electrolytic). As a source, it's best to use a stabilized PSU, as in any well-equipped workshop. With an ordinary supply-line PSU block, you don't usually get proper DC, but a pulsed voltage, so you need to fit a reservoir capacitor in parallel that will maintain the minimum voltage required at the regulator input at all times. The last place you can fit this is on the K1 terminal block, but it is often possible to "divert" two rows in the board area to insert an electrolytic capacitor of at least 10 μ F, at a working voltage suitable for the source being used, and observing the polarity carefully. We connect the source to this, and from there, we go off to the K1 terminal block. Pads are provided for a socket K2 after the switch for supplying power to another module. We might want to connect if required, say, a 3.3-V regulator with the center pin grounded, like the LF33 from STMicroelectronics.

Multi-purpose module (single-sided)

Inserting a resistor or an LED into the breadboard is not complicated, but it's so much handier to connect up and power everything together in a single circuit (**Figure 2**) with three LEDs and their series resistors, a potentiometer, or a push-button with pull-up resistor. This is a PCB to suit everyone—you can fit your choice of:

- 3 LEDs connected to ground—something you're always needing; the 1-k Ω resistor is fine for a low-current LED powered from 5 V;
- a preset potentiometer already connected to the power rail; you can always choose another value, but 10 k Ω is almost universal;
- a real potentiometer with a shaft, for carry-

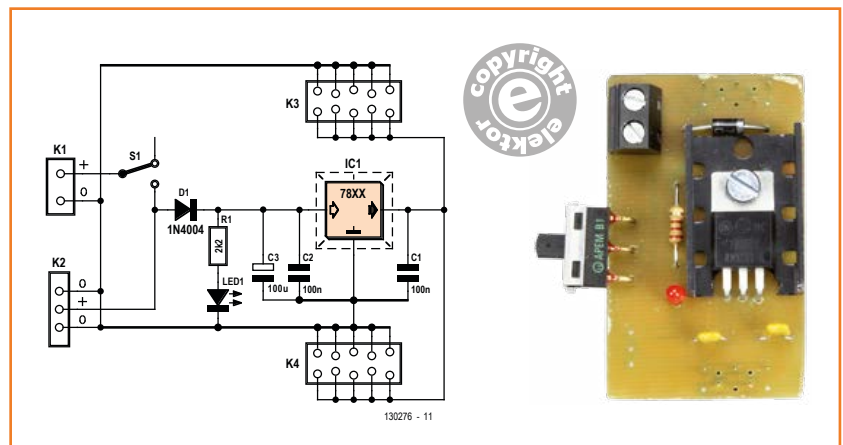

Figure 1. Power module circuit diagram.

- ing out adjustments with one hand;
- a pushbutton, because this type of component often has fat or ill-placed pins, difficult to install directly on the board; here, with a pull-up resistor to 'High' and going 'Low' when pressed;
- and there are still a few holes for fitting other components according to your needs, and the possibility of producing other useful assemblies.

LCD display module (single-sided)

On a liquid crystal display, a number of pins aren't used for controlling it (**Figure 3**): inputs D0–D3 are grounded; three resistors are needed for the E, R/W, and RS inputs, plus a potentiometer for adjusting the contrast. Ultimately, only

Figure 2. The circuit with six accessories: pushbutton, LED, and potentiometers.

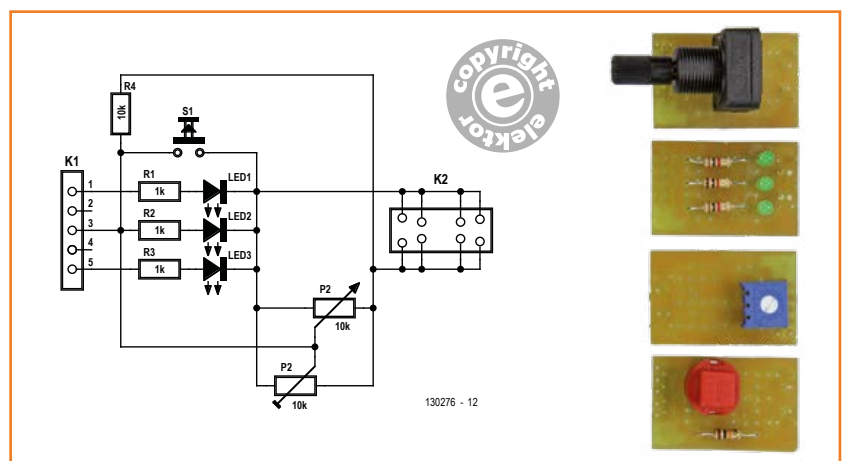

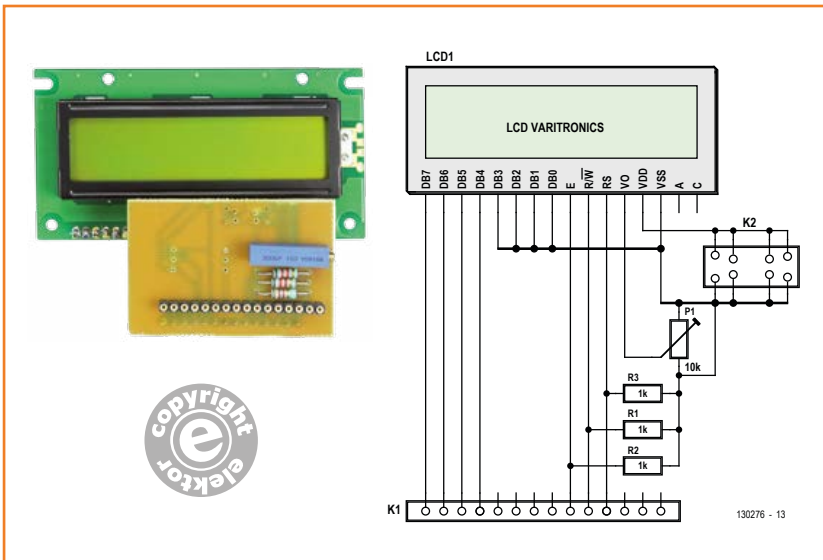
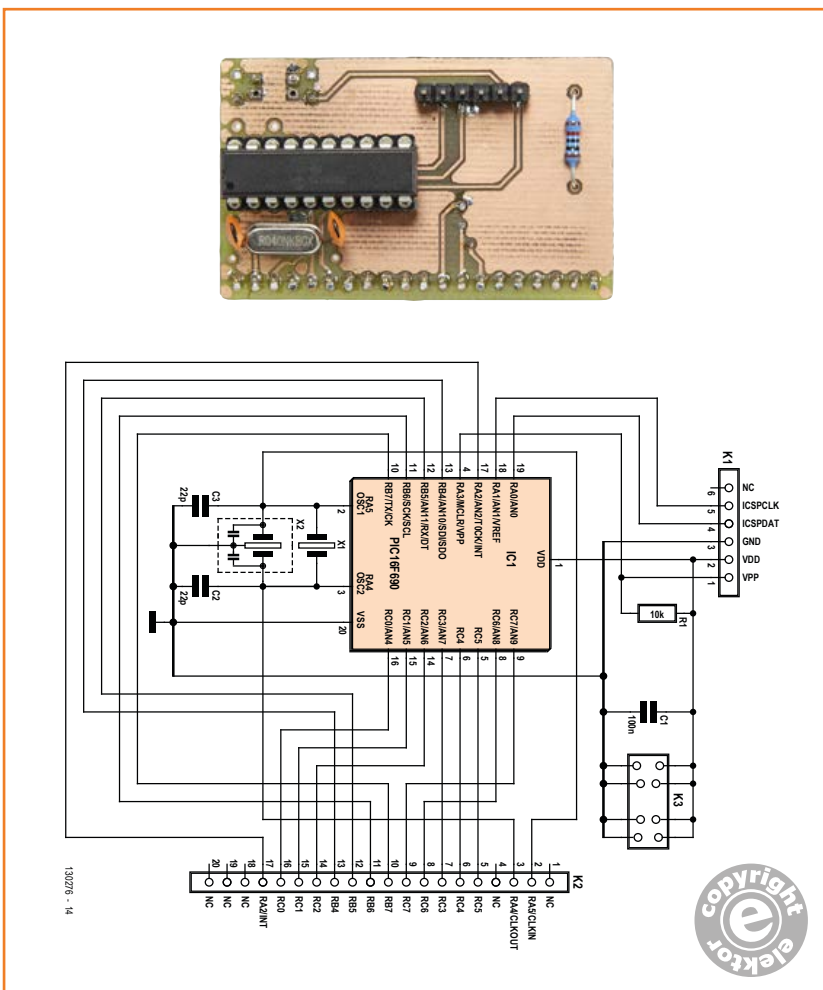

Figure 3. The liquid crystal display circuit is fitted piggy-back onto this mini module, which only has four components. The display module (single-sided) acts as an interface between the breadboard and the LCD circuitry originally mounted on its own PCB.



seven connections are useful: E, RS, R/W, and D4–D7, apart from the anode (+) and cathode if you want the backlight.

In this configuration, there are only four data bits to be provided, the display is in write mode – it is only able to receive data, so we save ourselves one command line.

The PCB is very simple and the display connects up using a single clip. Yet the module covers all the functions.

PIC16F690 and PIC24HJ64GP502 modules (double-sided)

With a great many of the test circuits I build, I often use microcontrollers, and wiring them on the board is always a chore, even when you're used to it. That's why I'm suggesting two mini modules (**Figures 4 & 5**) to cover the 16F690 and 24HJ64GP502 series PICs, which have similar connections:

- supply voltage and ground
- a small 100 nF decoupling capacitor on the PIC supply
- the right-angle connector K1 for the link to the Microchip PICKit 3 debugger, ICE with adaptor—this connector alone already makes these modules worthwhile
- the 20-pin or 28-pin connector is accessible for wiring to the test board; it will not clutter you up with unnecessary lines or ones that are already wired
- on the PIC16F module, there's room for a crystal or a ceramic resonator
- on the PIC24HJ64GP502 module, there's room for a ceramic resonator; there's also an LED connected via a jumper to the RA0 output on the PIC.

For many applications where clock frequency precision is not critical, you can do without the resonator and just use the internal oscillator.

Construction

Let's come back now to the variations in spacing between boards from different sources.

Figure 4.

The 16F690 PIC, accompanied here by a quartz crystal flanked by its usual capacitors.

In between the rails intended for the power supply, in the working area that often consists of two lots of five rows of holes either side of a central groove, everything's OK, the pitch is standard. But the edges are where you need to watch out. For the power rails, every manufacturer has their own standard.

To widen the compatibility of my modules, in collaboration with the Elektor Labs, we've adopted two types of board that are easy to source: the first type (**Figure 6a**), with holes on a pitch of whole multiples of 0.1 inch*, i.e. 2.54 mm, is sold by Selectronic (France), Farnell/Newark (global), and others.

On the second type (**Figure 6b**), offered by Velleman, the spacing between the power rails and the central working area differs by 0.025 inch (0.635 mm). The last outer row (power rail) is located 3/8 inch (9.53 mm) from the first hole in the central area, instead of 4 inches (10.16 mm) if we had the standard .1 inch spacing.

**This is not
ready-to-wear but
ready-to-fit**

As a result, so as to suit both models of board and have the pins properly in line with the holes in the board you are using (single- or double-sided), the PCB for each module has **two positions** for fixing the power connector pins, offset by a 1/4 grid unit. When you build a module, choose the appropriate configuration by first checking the board you're going to be using: on **Figure 6c**, you use either the bottom holes (marked in violet) if you have a Velleman board, or the top holes (marked in yellow) if it's a board with standard spacing. In so doing, you will correct the difference of 25 mils for fitting your headers. It's a pain, but Elektor thinks of everything!

Mechanics, symmetry, and polarity

To give the module good mechanical stability, you'll connect two rows of pins on the power rails and a certain number in the test area. The power connections will be made using SIL (single in line) pin headers, one with five pins, the other three, depending on the lines to be connected:

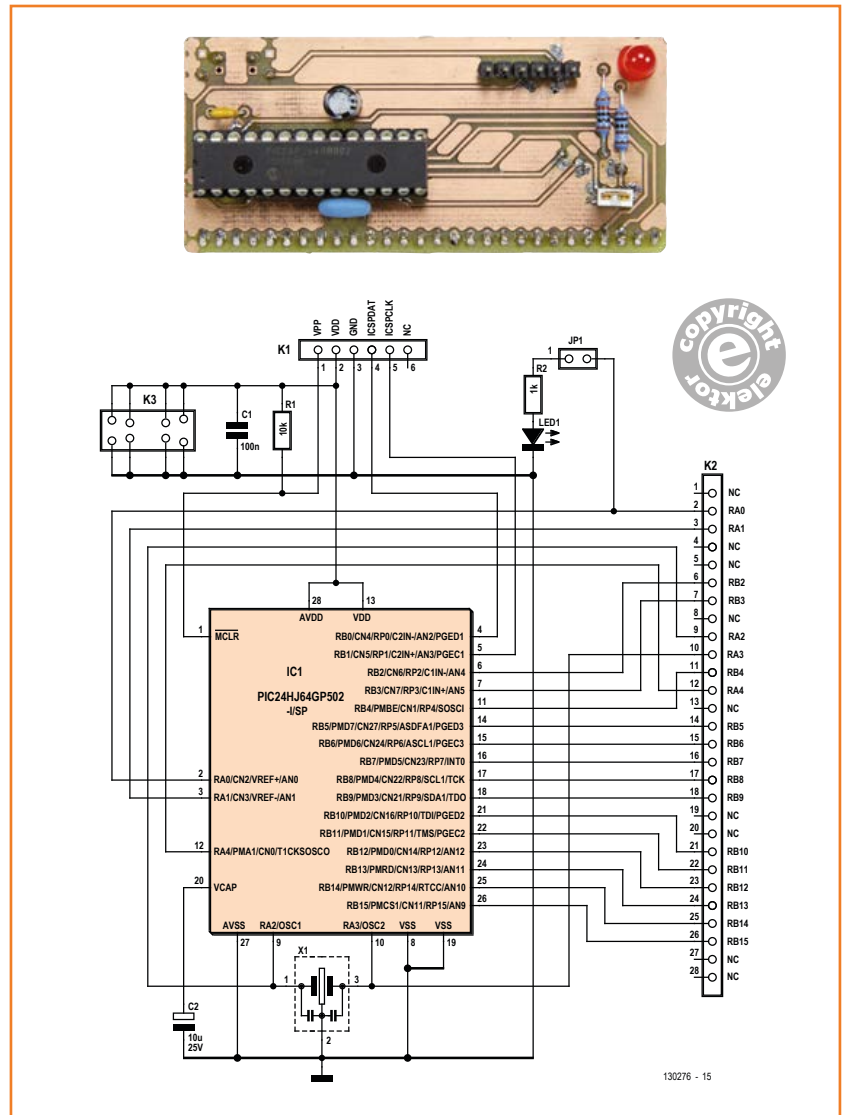

Figure 5. The PIC 24 mini module.

one must connect the outer holes together, so five pins; the other only the two inner ones. To make insertion easier, you can cut off the unused pins.

Some boards have polarity marking on their supply rails on the outer lines. If this polarity is positioned in the same sense (asymmetric) on both sides, and if you want to adhere to this polarity, it will only be possible to connect the modules on one side of the board!

NB Use only SIL pinheaders with fine, turned pins like the D01-9923246 by Harwin (Farnell/Newark # 1022218). Square pins damage the

* equal to 100 'mils' or 'thous'.

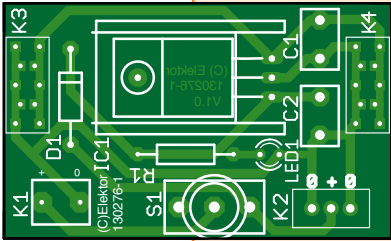

1. Supply Module, 130276-1

Resistors

R1 = 2.2k Ω

Capacitors

C1, C2 = 100nF (.2")
C3 = 100 μ F 25V, radial (3.5mm)

Semiconductors

D1 = 1N4004

IC1 = 7805

LED1 = LED, 3mm, low current

Miscellaneous

S1 = PCB mount switch, e.g. C&K Components
1101M2S3AQE2 (1437701)

Heatsink, 18K/W, for IC1, ML26AAG, Aavid Thermal-
loy, RS Components # 712-4260

K1 = 2-way screw terminal block, .2" pitch

K2 = 3-pin pinheader, .1" pitch

K3, K4 = 5-pin pinheader, user modified (see text)
Harwin D01-9923246 (1022218) (see text)

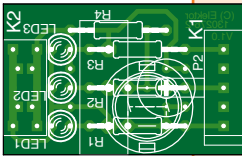

2. Multi-Purpose Module, 130276-2

Resistors

R1, R2, R3 = 1k Ω

R4 = 10k Ω

P1 = 10k Ω trimpot, alt. with spindle

Semiconductor

3 pcs LED, low current

Miscellaneous

K1 = 5-pin pinheader, Harwin D01-9923246 (1022218)

K2 = 5-pin pinheader, user modified, Harwin D01-
9923246 (1022218)

S1 = pushbutton D6C30LFS, C & K Components
(1201368)

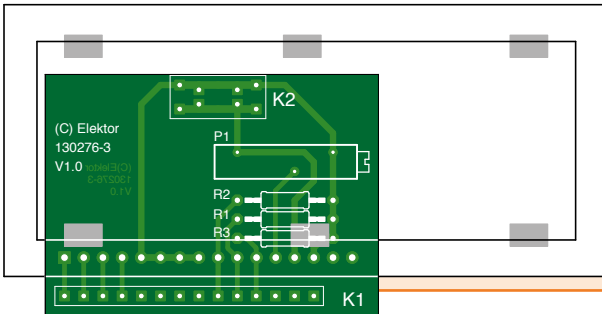

3. LCD Display Module, 130276-3

Resistors

R1, R2, R3 = 1k Ω

P1 = 10k Ω multi-
turn, Bourns 3006P
(9352295)

Divers :

K1 = 14-pin pinheader, Harwin D01-9923246
(1022218)

K2 = 5-pin pinheader, user modified, Harwin D01-
9923246 (1022218)

LCD1 = LCD, 2x16 characters, Vatronix TC1602C (Ele-
ktor Store)

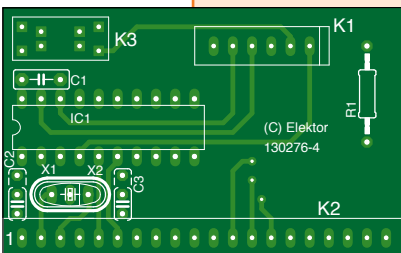

4a. PIC16F690 Module, 130276-5

Resistor

R1 = 10k Ω

Capacitors

C1 = 100nF
C2, C3 = 22pF (only with xtal X1)

Semiconductors

IC1 = PIC16F690-I/P

Miscellaneous

K1 = 6-pin pinheader, .1" pitch (e.g. 1822166)

K2 = 20-pin pinheader, Harwin D01-9923246
(1022218)

K3 = 5-pin pinheader, user modified, Harwin D01-
9923246 (1022218)

X1 = 20MHz quartz crystal (max.), or ceramic resona-
tor (no C2, C3)

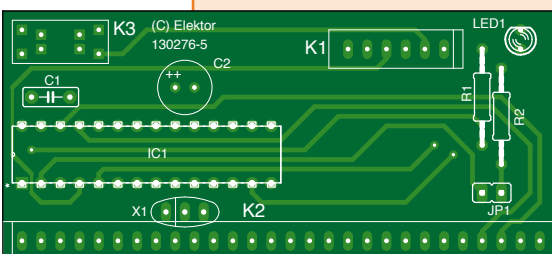

4b. PIC24HJ64GP-502 Module, 130276-5

Resistors

R1 = 10k Ω

R2 = 1k Ω

Capacitors

C1 = 100nF

C2 = 10 μ F 25V, radial

Semiconductors

D1 = LED, 3mm, low current

IC1 = PIC24HJ64GP502-I/SP

Miscellaneous

K1 = 6-pin pinheader, .1" pitch (1822166)

K2 = 5-pin pinheader, user modified, Harwin D01-
9923246 (1022218)

X1 = 20MHz (ceramic resonator)

JP1 = jumper



As this article—originally intended for the January/February 2014 double edition—was being prepared, it became clear that to reduce production costs, it would be necessary to group these little modules together onto a single board (panel), instead of producing them individually. And since in any case it seems only logical to use several at once or in turn, depending on the requirements of the applications envisaged, we might as well produce a set that would bring together on the same PCB several copies of the multi-purpose module and one copy of each of the other modules. This production technique is exactly what PCB manufacturers have been over the last few years, allowing them to rationalize their production by combining orders from several different customers onto larger boards and fabricating them all at the same time. After a little experimentation, it appeared that the optimum combination would be eight multi-purpose modules plus a single example of each of the four modules with a specific function, as shown in the **illustration here**, i.e. a set of 12 PCBs in a panel for around \$40 (tentative price). This panel is available online from **elektorPCBservice**. It would be a shame to miss out on these very handy accessories.

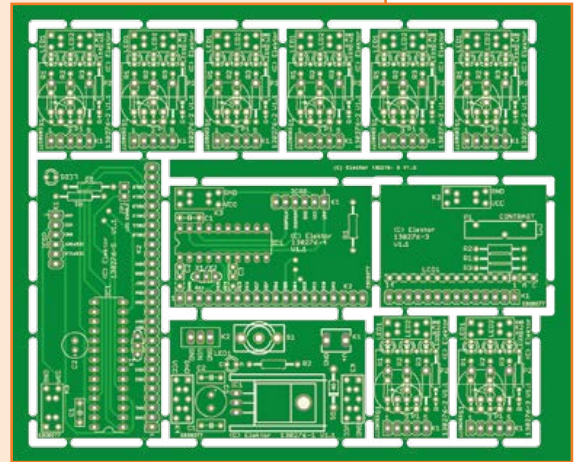

50% of real size

In conclusion, here's a glimpse of other modules Elektor will be offering you shortly. Jennifer is still working on them right now, but she's been kind enough to photograph some of her prototypes as an advance preview to illustrate this article.

Module	Description
-5V PSU	Small unregulated inverting -5 V PSU, 100 mA or 200 mA using 1 or 2 LTC660.
Arduino	Interface between breadboard and Arduino shields. Delivers 3.3 V and V_{in} (10 V) from the 5 V on the breadboard.
1 relay	3 types of relay possible. Simple transistor drive.
RS232	Ready-to-use RS232 Interface (RX, TX, CTS, and RTS). Plug the board into the Elektor BOB module. Select 3.3 V or 5 V by jumper.
ATmega	For using the ATmega328 with or without an ARDUINO bootloader. All its inputs/outputs are available on the breadboard. The ATmega328 is programmed using a standard programmer, but the Arduino bootloader is programmed via the Elektor BOB interface or the Arduino USB/Serial interface

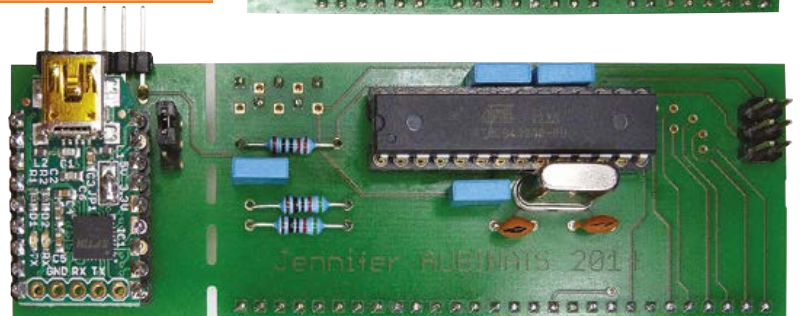
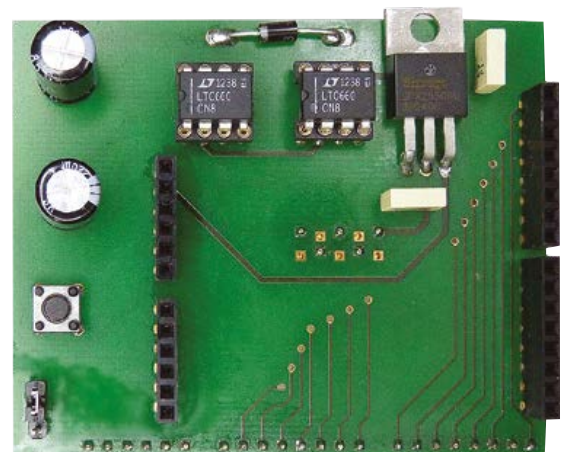

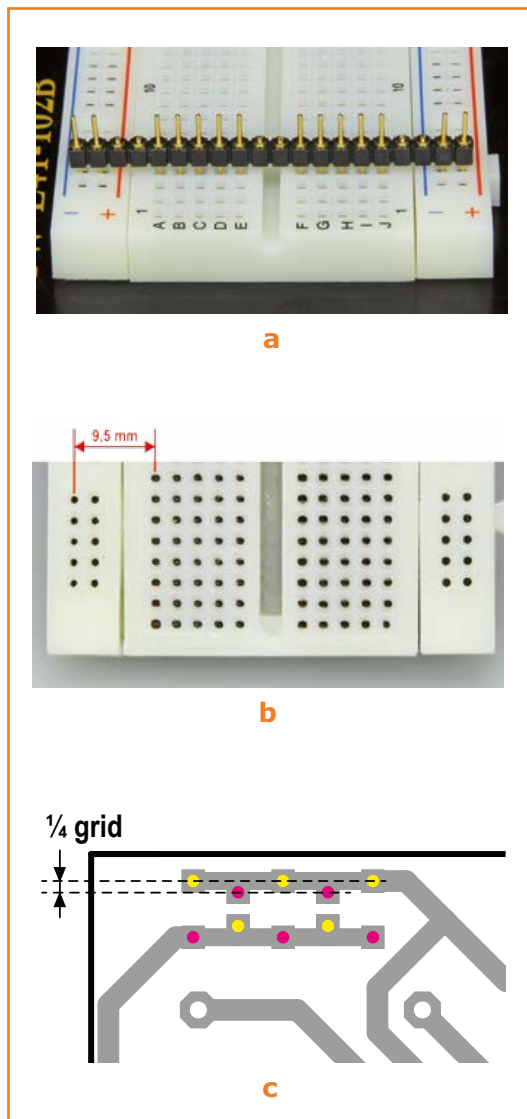
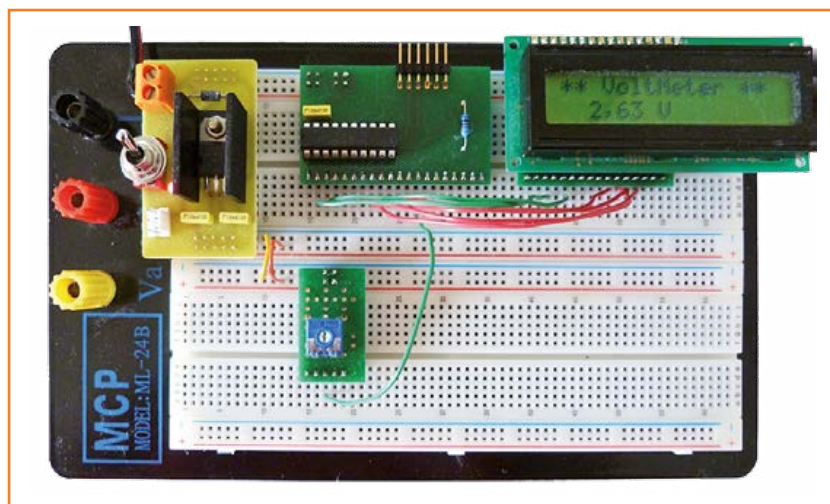

Figure 6. Depending on the types of breadboard, the spacing between the power lines and the working area may differ. Thanks to the clever way their power connectors have been offset, the mini modules can easily be adapted to both types.



board contacts! However, on the PIC modules, for programming and also for the power, you'll note we are using square pins for the PICkit programmer interface, as the turned pins would be too fine for this!

The pins are soldered on the copper side, allowing enough space to slip the iron tip under the plastic strip. For better alignment, keep the headers whole instead of separating the pins individually. On the power connectors, two of the pins in the row of five (2nd and 4th) and one of the pins in the row of three (the center one) have their heads cut off, as there is no hole at that point in the PCB.

PIC voltmeter and LCD display

As a construction example, I'm suggesting a PIC16F690 voltmeter and its LCD display on breadboards (Figure 7). It is of course made up of a 5 V power module, a PIC16, an LCD display, and a multi-purpose mini-module with preset potentiometer to provide a voltage to measure and display on the screen. All the track layouts (single- and double-sided) and the component overlays for the PCBs for these mini modules are available from our website [2].

Wiring up the power unit is simple. With the circuit diagrams for the microcontroller and LCD modules, you won't have any trouble finding your way around. In the case of data bit one, things depend on the PIC software used [2]. Fortunately, for the command lines, it's child's play. Want to give it a go?

I said at the start that there were only nine wires to fit—was I right?

Thanks to Marion, Thomas (selectronic.fr), and Jean-Luc (130276)

Web Links

- [1] www.aubinais.net
- [2] www.elektor-magazine.com/130276
- [3] www.elektorPCBservice.com

Figure 7.

Example of application for mini modules: an LCD PIC voltmeter with just nine wires to fit. If you have any other ideas for mini modules you feel might be useful to us, don't hesitate to suggest them (editor@elektor.com).

The Convenient All-in-One Solution for Custom-Designed Front Panels & Enclosures



FREE
Software



ONLY \$90.24
with custom
logo engraving

You design it

to your specifications using
our FREE CAD software,
Front Panel Designer

We machine it

and ship to you a
professionally finished product,
no minimum quantity required

- Cost effective prototypes and production runs with no setup charges
- Powder-coated and anodized finishes in various colors
- Select from aluminum, acrylic or provide your own material
- Standard lead time in 5 days or express manufacturing in 3 or 1 days

**FRONT PANEL
EXPRESS**

FrontPanelExpress.com
1(800)FPE-9060

Pololu

Robotics & Electronics

Pololu 4-Channel RC Servo Multiplexer

ITEM #2806

\$9⁹⁵



Allows for easy switching between
two independent RC signal sources.

Power HD Continuous Rotation Servo

ITEM #2149

\$14⁹⁵



- 40 g
- Specs at 6 V:
 - 71 RPM
 - 93 oz-in

Many other
servos
available

Micro Maestro USB Servo Controller

ITEM #1350

\$19⁹⁵



Conduct a symphony
of servos!

- USB, serial, and internal scripting control
- 6-, 12-, 18-, and 24-channel versions available

Pololu RC Switch with Relay

ITEM #2804

\$9⁹⁵



Enables easy control of large,
electrically isolated loads in radio
control systems.

Jrk 21v3 USB Motor Controller

ITEM #1392

\$49⁹⁵

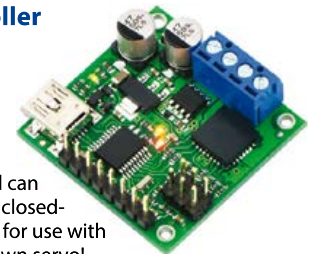

Highly configurable motor controller
that offers four control interfaces and can
optionally be used with feedback for closed-
loop speed or position control. Great for use with
our linear actuators or making your own servo!

USB Micro-B and Mini-B Breakout Boards

\$1⁷⁵

ITEM #2592



ITEM #2593

Linear Actuators

STARTING AT

\$66⁹⁵



- 2" to 12" stroke lengths
- Multiple speeds available
- Potentiometer feedback option

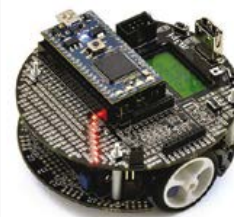

m3pi Robot

ITEM #2153

\$189⁹⁵

3pi upgrade
kit available

Enhanced version of our popular 3pi robot.
Uses the 32-bit mbed development board
to offer more processing power and free I/O
lines.

MaxBotix[®] Inc.

High Performance Ultrasonic Rangefinders

Phone #: 218-454-0766

Email: sales@maxbotix.com

Outdoor Sensor:



HRWRC Line
WRC Line
HRWR Line
WR Line

Indoor Sensor:



HRLV Line
LV Line
XL Line
USB Line

Save 10% NOW

Enter Code: EZSENSOR

Code valid thru April 2, 2014
One time use per customer

Order today at:

www.maxbotix.com/elektor

Common Applications:

- Security
- Antonyms Navigation
- Robots
- Tank Monitoring
- Industrial Applications
- Liquid, Water, Snow Level Measurement
- Proximity & People Detection
- Store Displays, Booths & Kiosks

Take your design from idea to reality.

Find out more at: www.pololu.com

DDS RF Signal Generator

An alternative approach

This is not a DIY project as you may have come to expect from Elektor, with a perfectly designed and extensively tested circuit board. Rather, in this article we show the ropes to building an RF circuit that functions well, using only common household resources and a good deal of skill. In this case it's a DDS RF Signal Generator, with output signals up to several hundreds of megahertz.

By **Wim Knoeff**, PA3EHN (Netherlands)

In Elektor we frequently publish articles about projects submitted by our readers. Often these are circuits that appeal to us, either because of their unusual design or the novel solution, but nevertheless are not sufficiently significant or detailed to warrant a complete redesign by Elektor Labs. The generator described here also falls into this category, but for completely different reasons.

When we first looked at the circuit for this DDS Function Generator, we found it hard to believe that it actually worked. The author has set about building the circuit using entirely his own methods, doing without the usual schematic and PCB CAD software that is common today. Everything is done by hand—a PC is only used for program-

ming the microcontroller.

Perhaps modern electronics designers will consider this approach old-fashioned, but in this case we prefer to think of it as 'unconventional' or even 'innovative'. In this article we describe the design and construction of a DDS-based RF signal generator with an output range to 100 MHz and various additional features, such as amplitude modulation, split frequency, 10 or 50 kHz back-and-forth scanning and automatic selection

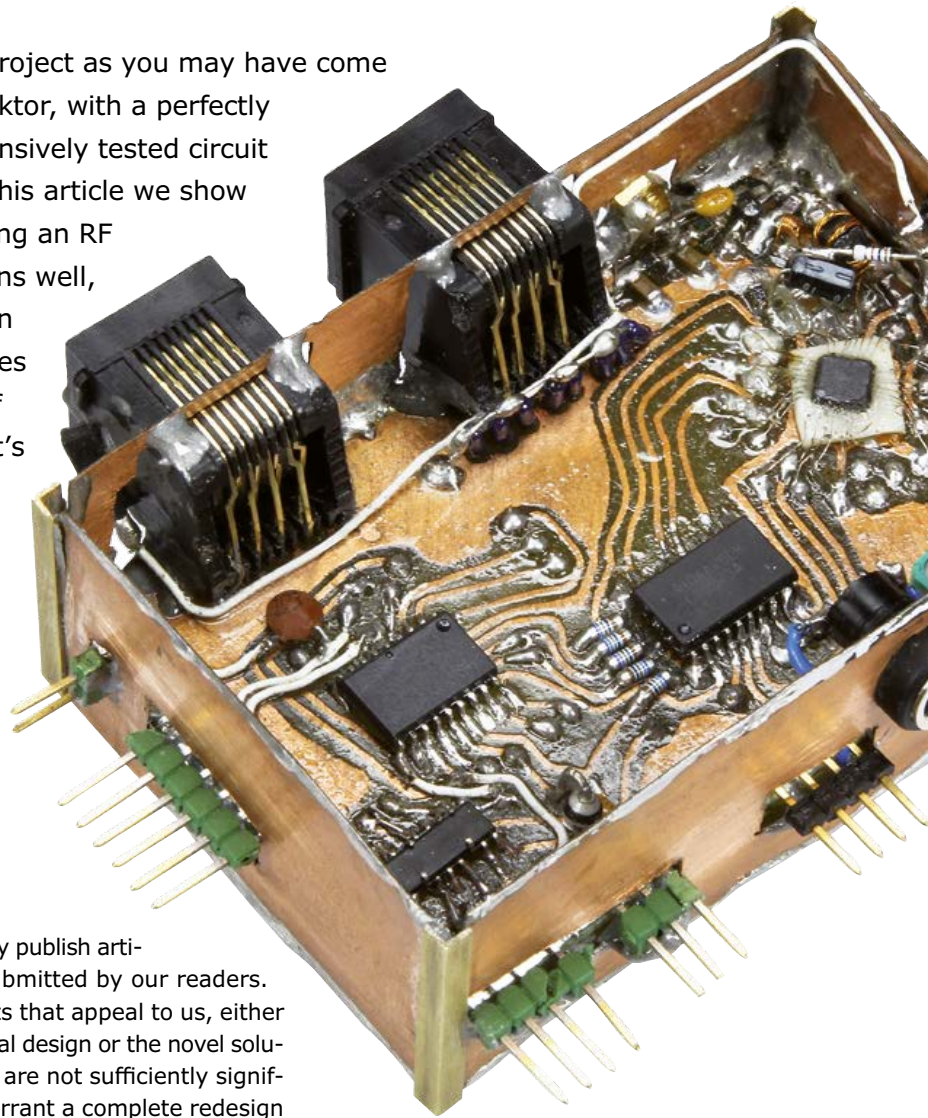

of band filters. The project in its present state is not intended as a circuit that anyone can replicate without much thought, but serves as an inspiration of how you can work with modern electronics in a different way!

Schematic

The AD9913 [1] used here is a direct digital synthesizer (DDS) with a low power consumption suitable for use in portable equipment. It has a 10-bit D/A converter with a sampling rate of 250 Msamples/s. The AD9913 can generate sine wave signals up to 100 MHz at its analog output, thanks to its fast DAC and high internal operating speed. The AD9913 also offers fast frequency hopping and fine tuning, as well as an accurate phase offset adjustment.

The oscillator signal for the AD9913—the reference clock frequency—is generated by a 25-MHz crystal connected to DDS pins 13 and 14. The oscillator circuitry itself is inside the DDS chip;

frequency calibration is done with a trimmer connected to the crystal, see **Figure 1**. This oscillator signal is subsequently multiplied by the DDS PLL to the system clock frequency that is used internally by the DDS IC.

The operating buttons S1 to S7, via a priority encoder with eight inputs (IC1), together with a rotary encoder connected to pins 17 and 18 of the microcontroller IC2 (a 16F648A) set the desired operating mode; this supplies not only the required digital bit stream for configuring the DDS-IC, but also the data for the two-line LCD. The data for the DDS IC goes via IC4 (74LVC373A, an 8-way latch with 5-V compatible inputs) to the AD9913. By doing so the 5-V signals from IC2 are adapted to the DDS-inputs, which operate at 1.8 V.

One signal from this bit stream (RA7 from the PIC, CS for the DDS) also takes care of reading the band filter data in IC3 (a 4-bit latch 74LS375). The power supply is split between a 5-V part for the microcontroller and surrounding components and a 1.8-V part for the DDS. The 1.8-V supply is further divided into an analog part and a digital part, using 2 separate regulators.

Figure 1. The basic schematic for the DDS generator, redrawn for this article in Elektor style. The additional AM circuit is not shown here.

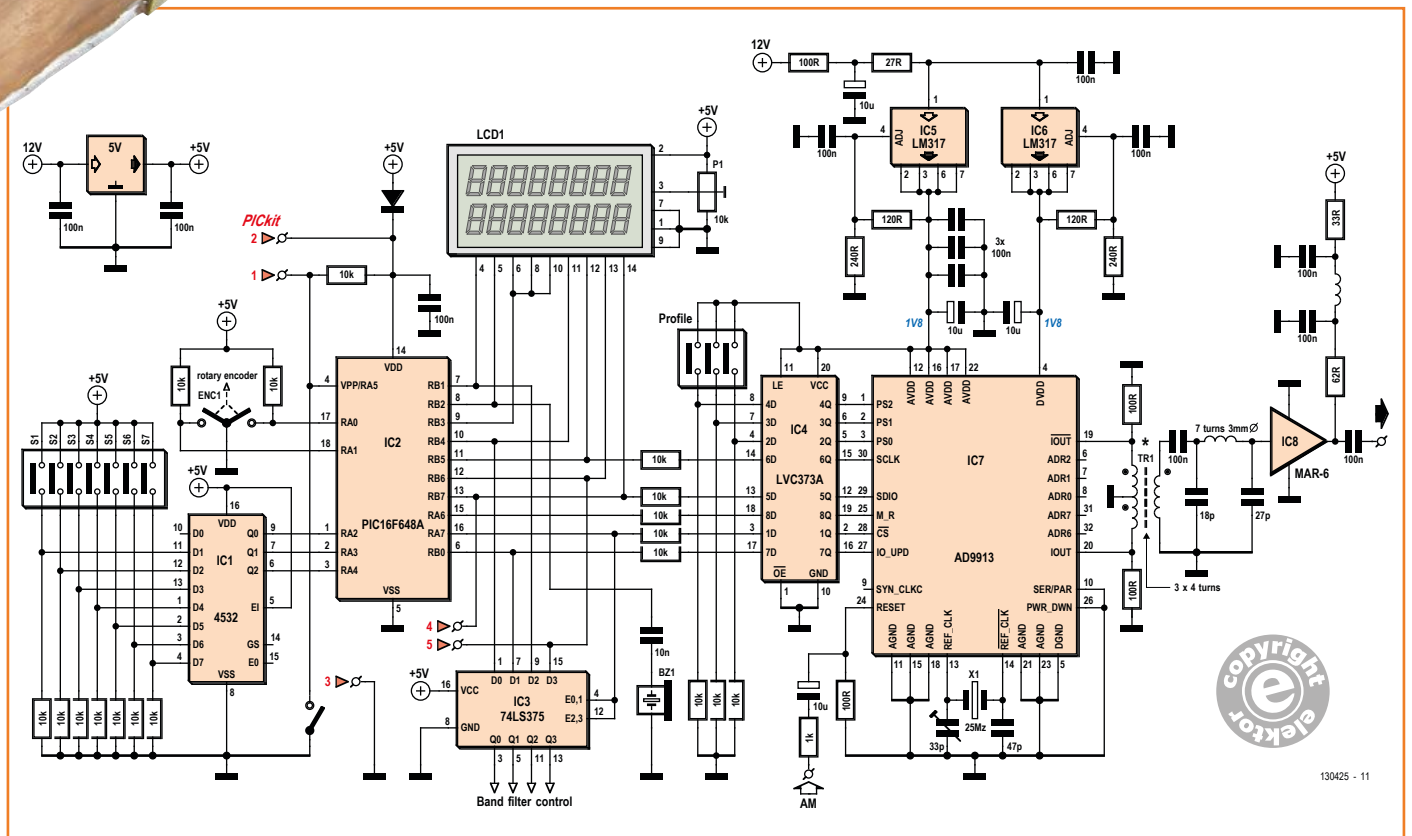

130425 - 11

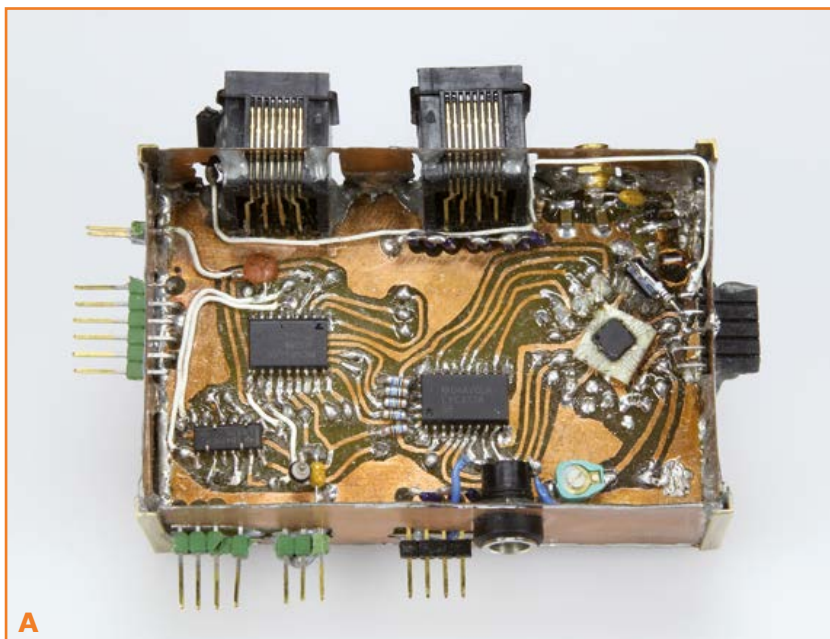

A

Figure 2.
Top side (A) and bottom side (B) of the circuit built by the author.

The two complementary DDS output signals (pins 19 and 20) are combined in a small transformer which has a toroidal core with a trifilar winding (for the suppression of even harmonics, among other reasons, refer to the application note from Analog Devices AN-912 [2]) and arrive via a pi-filter at the input of output buffer IC8 (MAR6). The output buffer then connects to the output connector.

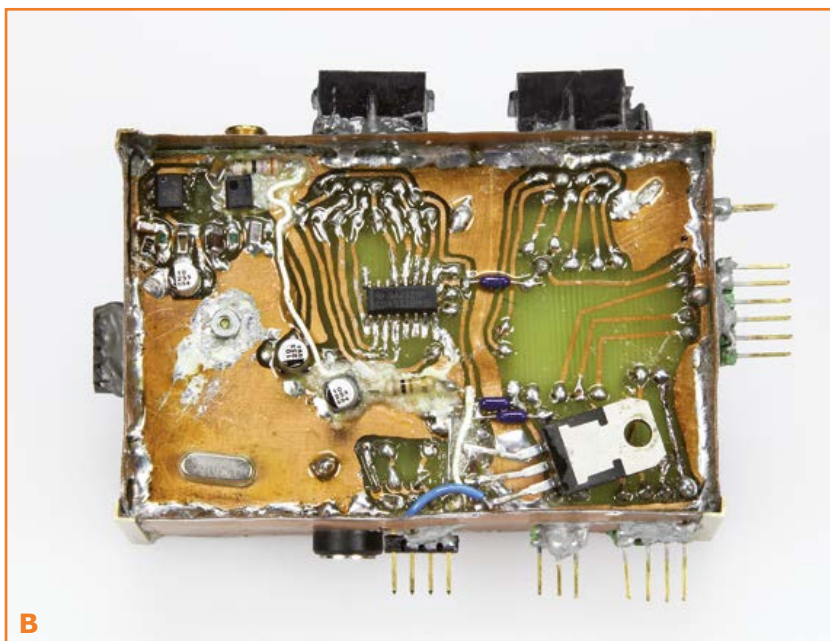

B

The construction

The author designed a double-sided circuit board, drawn by hand, for this circuit (see photos in **Figures 2** and **3**) and so shows that it is possible to build complex circuits (even those containing SMD components) reasonably easily and which are still reliable. In the article *Soldering LFCSP ICs by Hand* [3] in last month's issue we already described how you can solder the DDS-IC to the circuit board using individual wires.

For the enthusiasts, the complete printed circuit board layout for this project can be downloaded from the project page at the magazine website [4]. Here we only show the final result. While it is very different from a normal Elektor project it nevertheless works very well, even at high frequencies.

We will briefly describe the order of construction to illustrate the work method. Firstly the through-board connections between the top and bottom side of the circuit board are made. This is followed by the power supply ICs and everything related to those (the 5-V regulator is mounted upside down), the connectors, the HEF4538 on the bottom side of the board and the 74LS375 and 16F648A on the top, the MAR6 and all its accompanying parts and all parts around the DDS and a few wire links. All ICs are in SMD packages, the other parts are not very critical.

The author chose two 8-way data cables with RJ45 connectors for the connections to the LCD and the 7 (make-) switches to simplify disconnecting and making changes. The +5-V power supply wire to the LCD is a separate wire with a miniature plug and socket connection, which is next to the RJ45 for the LCD. The download [4] that belongs with this article, in addition to the layout for the top and bottom of the circuit board, also contains the connection diagrams that show all of the wiring.

After this the HEX file, also available from [4], can be programmed into the 16F648A to check everything (refer to the heading 'Software'). Following this check the 74LVC373 is soldered onto the circuit board and the control signals to the DDS and its connections can be verified.

Mounting of the AD9913

The final step is to mount the prepared DDS IC with its new connecting wires and ground

stud [3] on the circuit board. First connect the ground planes on the top and bottom side of the circuit board together by soldering a small piece of copper strip, which is passed through the (3-mm) hole for the ground stud, on the top and bottom. After this, the ground stud on the DDS IC is pushed through the hole with the copper strip, with the connecting wires aligned as much as is possible with their respective circuit board connections. Now screw on the nut on the DDS ground stud on the bottom side of the board. Tightening lightly will suffice. Note: after this never turn this nut again! Before assembling, apply heatsink paste to the ground stud, copper strip and circuit board.

Finally the DDS wires are cut to length and soldered in place; use an illuminated magnifier and an earthed soldering iron! DDS pins 6, 7, 8, 9, 31 and 32 remain unconnected.

After connecting the 12-V power supply and switching-on there is of course a moment of tension as to whether everything has been built and connected correctly; the author's 3 prototypes all worked first time! These prototypes were finally sprayed with so-called colorless automotive underbody protection, which provides durable protection against corrosion and some robustness to the SMDs on the board.

Software

The source code (.ASM) for this generator has been worked on for many years by various authors. It is the intention to keep this code as clear as is possible, so that it can be used as a springboard for further additions. The file can be opened in Notepad. It is then, for example, possible to change the IF frequency (preference: DDS frequency higher than LCD frequency), or adjust the maximum output frequency.

Every (modified) source code then has to be converted into a HEX file using MPASM [5]. This HEX file is subsequently loaded into the 16F648A using a programmer (for example a PICKit2) connected to the 'PICKit' connector on the side. This requires disconnecting the power supply and the LCD cable.

After the power supply is switched on, the LCD first shows the PLL factor and the maximum output frequency of the programmed software, while

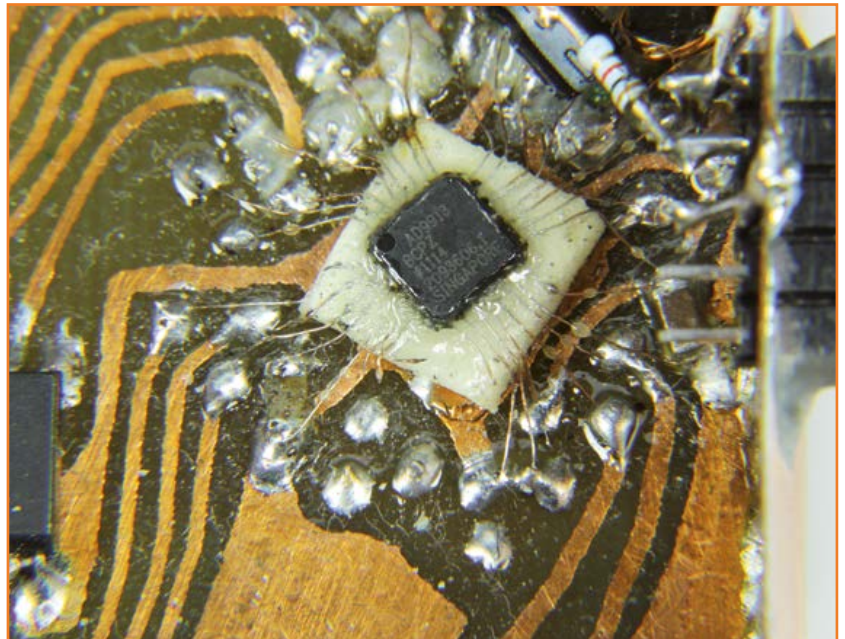

the buzzer sounds a few welcome beeps. After this, the initial frequency (28.5 MHz) is shown on LCD line 1, after turning the encoder it also appears on LCD line 2.

In the download file for this article [4] you will find several software variants. These (source code and HEX files) are named according to their PLL factor and maximum output frequency (for example: '10x_120mc').

(130425-1)

Figure 3. The mounting of the DDS chip on the board. The @ home procedure of how to prepare this IC was described last month [3].

Web Links

- [1] www.analog.com/static/imported-files/data_sheets/AD9913.pdf
- [2] www.analog.com/static/imported-files/application_notes/AN_912.pdf
- [3] www.elektor-magazine.com/120246
- [4] www.elektor-magazine.com/130425
- [5] www.microchip.com/mplab

EE Live!

Join us at the Industry's Leading Embedded Systems Event – EE Live!

With cutting edge product demonstrations, visionary keynotes, 200+ exhibitors and hundreds of essential training classes, EE Live! is the annual event for the embedded design community to learn, collaborate, and recognize excellence.

ESC

More to see, do and learn than ever before.

EMBEDDED SYSTEMS
CONFERENCE

MARCH 31 – APRIL 3, 2014 | SAN JOSE, CA | EELIVESHOW.COM

Engineering Summits



INTERNET OF THINGS
ENGINEERING SUMMIT



HARDWARE STARTUP
ENGINEERING SUMMIT



BLACK HAT EMBEDDED
SECURITY SUMMIT

Two-Day Intensives



ANDROID ENGINEERING
CERTIFICATE PROGRAM



SUPER C++ TUTORIAL
STROUSTRUP & SUTTER



FPGA ENGINEERING
BOOT CAMP

Keynote Speakers



Michael Barr
CTO and Co-Founder
Barr Group
Tuesday, April 1st
9:30 – 10:30 AM



Andrew "Bunnie" Huang
PhD EE and Hardware Hacker,
Author - *Hacking the Xbox*
Wednesday, April 2nd
9:30 – 10:30 AM

REGISTER NOW AND SAVE 20% OFF AN ALL ACCESS
PASS WITH PROMO CODE: IEEE20

SPONSORS

Diamond



Silver



UBM
Tech

WIZnet

CONNECT THE MAGIC 2014 DESIGN CHALLENGE

LAUNCH: MARCH 3 / DEADLINE: AUGUST 3

Your mission?

Join the IoT revolution by designing an innovative 'Net-enabled electronics system using WIZnet's WIZ550io Ethernet module or W5500 chip.

Your reward? **A share of \$15,000 in cash prizes** and worldwide recognition from WIZnet, Circuit Cellar, and Elektor!

Anyone with a WIZ550io Ethernet module or W5500 smart Ethernet chip is encouraged to participate. WIZnet is providing 2,000 complimentary WIZ550io Ethernet modules for all those who qualify! Requests are served on a first come, first served basis while supplies last. The competition starts on March 3, 2014 at 12:00 PM EST and ends on August 3, 2014 at 12:00 PM EST. Get started today!

www.circuitcellar.com/wiznet2014

WIZnet's WIZ550io module is a complete Ethernet solution that includes the W5500 smart Ethernet chip (10/100 MAC/PHY, hardware TCP/IP, 32KB RAM buffer) and network interface (transformer and RJ-45) along with built-in MAC and default IP addresses.

For technical support: wizwiki.net/forum

To purchase: shopwiznet.com or shop.wiznet.eu

POWERED BY



circuit cellar



Sign up for CC.Post to receive announcements and notifications!



AC-AC & AC-DC Power Adapter Tester

Check 'm out!



Sure, that 50-cents non-returnable AC power adapter you found in the Unlabeled/NoWarranty/NoNothing bin the local thrift shop is a bargain and defeats any effort at building your own small power supply, but R U sure it's the right voltage-out? And what's the plug polarity, and the spec on current-out? Who knows it may even be AC-out.

By **Charles (Chuck) Hansen (USA)**

The finished board (duh, K1 is missing) and the plastic case with the "user manual" on the front panel.

A while back, along with a bunch of yard sale electronic components, I received a box of AC power adapters—which also go by the names of "wall warts" and "battery eliminators" to mention but a few. The voltage and current ratings were identified on some of them, whereas others

had their ID tags damaged or missing entirely. In order to sort through and test them I made a small test fixture box that allows me to connect adapters with standard 2.5 x 5.5 mm and 2.1 x 5.5 mm "coaxial" (barrel) plugs, and 3.5-mm mini-phone "jack" (ring & tip) style plugs. Let's say you plug a 14 V DC power adapter into the 2.5 mm jack socket of the Tester. The LEDs show it is a DC unit with +polarity (red LED) on the Pin/Tip and -polarity (green LED) on the Ring.

How it works

The extremely simple schematic diagram for the AC & DC Power Adapter Tester is shown in **Figure 1**. The power adapter is plugged into the appropriate matching jack K1, K2 or K3. The center parts of K1/K2 and the tip connection of K3 are connected to the anode of the red LED and the cathode of the green LED, both contained in bicolor LED LED1. Likewise the outer sleeves of K1 and K2, and the ring of K3 are connected to the second bicolor LED, LED2. LED1 and LED2

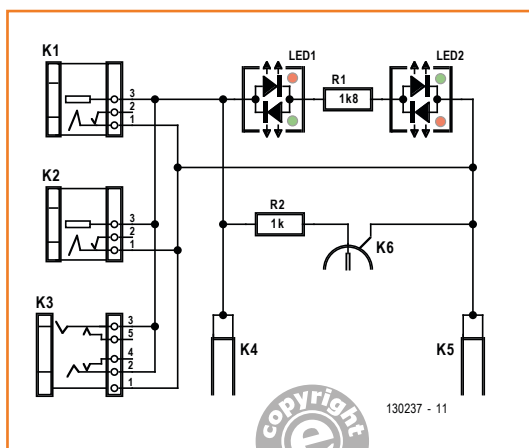

Figure 1. Two bicolor LEDs should end all worries and confusion about El Cheapo, ex Thrift Shop, AC power adapters.



are interconnected through R1, which limits the LED currents. If AC is applied, both LEDs light bright orange/yellowish.

PCB-mount banana sockets K4 and K5 are available to connect a resistive load to ascertain the load rating of the wall wart under test. Generally speaking, the rated full-load voltage is about 95% of the open-circuit no-load voltage, but be prepared to see wide deviations here.

You can monitor the output voltage with a voltmeter connected to BNC socket K6. Series resistor R2 was added to limit the current to safe levels because users may forget to select the voltage range on the digital multimeter (DMM), thereby giving occasion to search for a new protection fuse for the ohms or current range previously selected. This resistor is not required for faithful readers of *Retronics* and all others who are careful enough to make sure the proper voltage range is set for the adapter you are testing. As always, unless you have an auto-ranging meter, it is best to start with a high voltmeter range and work down to the actual voltage. If fitted externally the banana jacks should be spaced ¼ inch apart to allow for connecting dual-banana test lead connectors with this standard U.S. spacing.

Build it

A printed circuit board (**Figure 2**) was designed for the circuit, it's dimensioned to fit in a small, hard-plastic (ABS) enclosure. The header illustration shows the built up board and the case. K1 is missing on the prototype board—at the time of photography Elektor Labs were out of stock of 2.5-mm adaptor sockets for PCB mounting. Total parts cost of the author's prototype (built using point-to-point wiring) was about \$14 based on components purchased from Mouser.

A suggested front panel layout is shown in **Figure 3**—the symbols and colors used should prove helpful to make the Tester as easy to use as possible. Using the free download file at [2] you should be able to laser copy the artwork to adhesive-backed transparent drafting applique' film. Then apply the lettered film to the (painted) top of the tester case in the proper locations. Cut through the film at the holes drilled for the LEDs, and then if necessary spray it with two coats of clear polyurethane for protection.

Adapters allsorts

AC power adapters are available in voltages as high as 56 V_{DC} or 24 V_{AC}, and currents in excess

Component List

Resistors

R1 = 1.8kΩ
R2 = 1kΩ

Semiconductors

LED1, LED2 = LED, bicolor light red/green, 5mm (2112114)

Miscellaneous

K1 = adaptor socket, barrel type, 2.5mm, PCB mount (1608726)
K2 = adaptor socket, barrel type, 2.1mm, PCB mount (1608727)
K3 = adaptor socket, ring/tip type, 3.5mm, PCB mount (1243244)
K4 = banana socket, PCB mount, black (497344)
K5 = banana socket, PCB mount, black (497332)
K6 = BNC socket, bulkhead, right angled, PCB mount (2293737)
PCB # 130237 [2]

(numbers in round brackets are Newark/Farnell order codes)

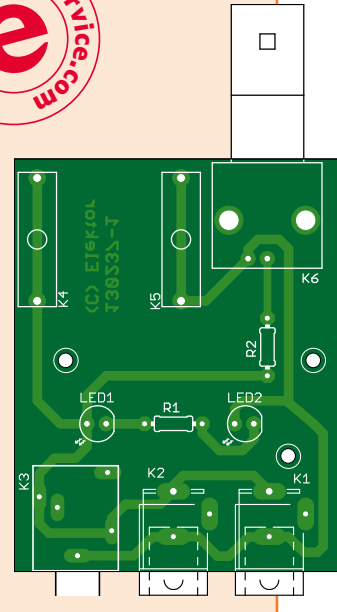

of 12 amps. This tester was designed for, and tested with, the more commonly available power adapters whose outputs are rated from 5 V_{DC} to 24 V_{DC}, and up to 18 V_{AC}. Don't be surprised to find adapters with the uncommon negative polarity on the Pin or Tip. Or adapters humming away and getting hot only.

(130237)

Figure 2. The simple and spacious circuit board designed for the AC & DC Power Adapter Tester.

Web Link

[1] www.elektor-magazine.com/130237

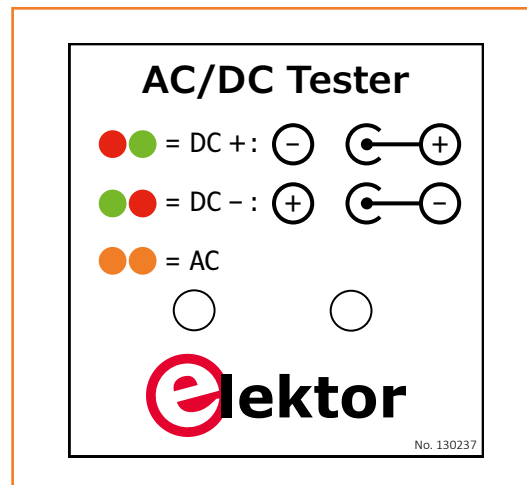

Figure 3. Example of lettering and signage on the front panel. Download the artwork and adapt the layout and size to your needs and preferences.

One Protocol for the Internet of

By **Jens Nickel** and **Benedikt Sauter**

The Internet of Things (IoT) is set to change our lives. Once every 'thing' is connected to a net we need a common language, so far there has only been agreement that net protocols such as TCP/IP will be used. What's missing is a universal application-layer to allow sensors and actuators from different manufacturers to inter-operate successfully. From our perspective this would seem to be an ideal job for the community! The call goes out to all interested engineers, designers and makers to send us your ideas and solutions.

The Internet of Things (IoT) is without doubt the flavor of the month. It's hardly surprising; once computers, smartphones, utility meters, environmental sensors, lighting, heating, household appliances and every 'thing' are hooked up to a network the possibilities become truly mind-boggling. The IoT has the potential to make our lives more secure and comfortable and help us in the future to manage energy usage and resources more efficiently. The two pivotal factors that make this 'fourth industrial revolution' possible are firstly the arrival of small, low-cost, powerful yet low-energy microcontrollers. These allow a growing number of devices to be given sufficient processing power to communicate with one another over a network. The second factor is the arrival of IPv6, the latest version of the 'Internet Protocol' (IP) which now accommodates a staggeringly large address space of 340 trillion trillion trillion. Every light switch, LED lighting unit, temperature sensor and so forth can now be assigned a unique global address.

Existing protocols of the IP suite including TCP and HTTP are used to ensure reliable error-free communication at the transport layer and request-response exchange at the application layer respectively for the IoT. These protocols only define the framework for message exchanges (which typically will consist of measurement values and control commands). To ensure that devices from different manufacturers can successfully inter-operate it is necessary to define an additional application-orientated protocol. This would then define, for example the format of sensor measurements (which may consist of a number representing the measured value, the units of measurement and a time stamp) and how it should all be coded into a message.

@ Protocol Zoo

Unfortunately at the moment there are already a large number of different protocols developed to accommodate different IoT application environments.



Things!

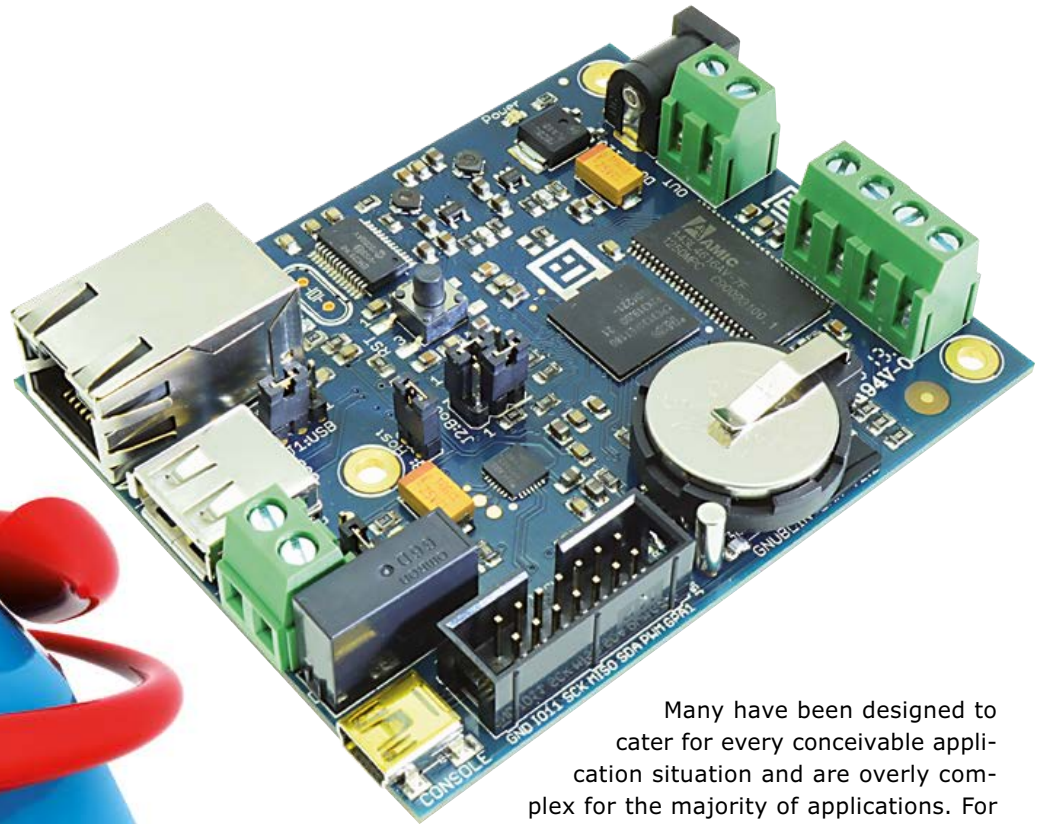

Many have been designed to cater for every conceivable application situation and are overly complex for the majority of applications. For small companies, start-ups and development labs bringing IoT products to the market place the choice of a suitable protocol can be confusing.

Elektor and the *Embedded Projects Journal* make an appeal to the Community, to develop a single general solution for the IoT protocol. We are looking for a simple solution which can be incorporated into a project with minimum effort and will install and run on a small microcontroller. It goes without saying that the final protocol will be completely free to use.

A few constraints

The Internet of things is by definition, all encompassing. The potential is enormous, for this initiative we have deliberately focused on just a few example application scenarios relevant to small businesses, engineering departments, High school teams and Open-Source-Initiatives who are likely to develop products and solutions for the IoT.

The finished protocol should comply with the following constraints:

- For test purposes it will be necessary to communicate with the devices using a standard browser (input using the address field and output in an HTML window).
- The protocol should be based around ASCII characters and not binary.
- All data frames should conform to a known standard i.e. JSON, XML etc. which are already widely supported in many programming languages.
- Implementation on an Internet server (PC, Tablet) must be possible.
- It should be possible to encrypt communications.

Seeking partners!

To establish a general-purpose protocol is a big undertaking – we will only be successful when uptake of the protocol (both in hardware and software) occurs as quickly as possible. To this purpose we already have partners on board and we are looking for more. It goes without saying that partners can also send in their own suggestions for the protocol!

To be a partner it will be necessary for companies, Start-Ups und Open-Source-Initiatives to fulfill a few conditions

(see www.iot-contest.com/index.php?content=partners).

Participation in this initiative is otherwise completely free.

Our partners to date on this initiative include:

Embedded Projects (www.embedded-projects.net)

WIZnet (www.wiznet.eu)

TinkerForge (www.tinkerforge.com)

NetIO (<http://netio.davideickhoff.de>)

XTRONIC (www.appicals.de)



We have suggested three application scenarios where the protocol is used to provide communication. These 'user cases' include a laboratory environment for measurement and testing, home automation and general communication between appliances. (see www.iot-contest.com/index.php?content=infos).

Your suggestions and solutions can reference these 'user case' examples but they are only provided as guidelines. We welcome other application examples and new ideas that you want to share with the rest of the community. The same applies to the environment; our suggestions are only intended to provoke debate and brainstorming.

An existing protocol may fit the bill, if you know of one that is suitable, we welcome this suggestion also!

The roadmap

All interested parties have until the 1st August 2014 to send in their solutions and ideas using the web site www.iot-contest.com. After this

we start the evaluation phase where we discuss and evaluate the merits of the submitted protocols. Any interested party wishing to participate in this phase should register for the Newsletter on the web site which will keep them up to date.

In the evaluation phase it is important to extract a common protocol from the (hopefully) wide palette of suggestions we receive. It is important that the details and description of the final protocol can be presented in the form of a poster which we will then make available as a free download for everyone.

Shortly after this phase we will start to see hardware and software products appearing which support the IoT protocol. The project partners will take care of this activity. (see box).

We will keep you up to date on this initiative in our next edition. Stay tuned and join in!

(130447)



FRONT PANELS & HOUSINGS

Cost-effective single units and small production runs

Customized front panels can be designed effortlessly with the Front Panel Designer. The Front Panel Designer is available free on the Internet or on CD.

- automatic price calculation
- delivery in 5-8 days
- 24-Hour-Service if required



Sample price: 34,93€ plus VAT/shipping

Schaeffer AG · Nahmitzer Damm 32 · D-12277 Berlin · Tel +49 (0)30 8058695-0 Fax +49 (0)30 8058695-33 · Web info@schaeffer-ag.de · www.schaeffer-ag.de

LCR + Stability Measurement

Use the Cleverscope FRA panel to easily auto plot Gain/Phase, Impedance, Capacitance or Inductance vs Frequency. Display the Gain and Phase Margin. Check for instability.

See our FRA tutorial video to show you how to verify your operating power supply or amplifier design. Check the impedance of your DC buses. Verify magnetics you have wound. 80 dB dynamic range! 0 - 65 MHz isolated Sig Gen.

Easy As, with Cleverscope.



100uH toroid

Streaming 100 G samples to disk ♦ Frequency Response Analysis ♦ Protocol Analysis ♦ Symbolic Math ♦ Matlab Interface ♦ 80 dB dynamic range ♦ 100 MHz Bandwidth ♦ Tracking Zoom ♦ 0-65MHz isolated sig gen ♦ Video Tutorials



CS328A-FRA
14 Bit MSO



www.cleverscope.com

Take out a FREE membership to Elektor.POST

- The latest on electronics and information technology
- Videos, hints, tips, offers and more
- Exclusive bi-weekly project for GREEN and GOLD members only
- Elektor behind the scenes
- In your email inbox each Friday



Register today at www.elektor.com/newsletter

Professional Quality
Trusted Service
Secure Ordering



Elektor PCB Service at a glance:

- 4 Targeted pooling services and 1 non-pooling service
- Free online PCB data verification service
- Online price calculator available
- No minimum order value
- No film charges or start-up charges

Delivery
from 2
working
days

Join the Elektor Community

Take out a GOLD Membership now!



Your GOLD Membership contains:

- 8 Regular editions of Elektor magazine in print and digital
- 2 Jumbo editions of Elektor magazine in print and digital (January/February and July/August double issues)
- Elektor annual DVD-ROM
- A minimum of 10% DISCOUNT on all products in Elektor.STORE
- Direct access to Elektor.LABS
- Direct access to Elektor.MAGAZINE; our online archive for members
- Elektor.POST sent to your email account (incl. 25 extra projects per year)
- An Elektor Binder to store these 25 extra projects
- Exclusive GOLD Membership card



ALSO AVAILABLE:

The all-paperless GREEN Membership, which delivers all products and services, including Elektor.MAGAZINE, online only.



Take out your Membership now at www.elektor.com/member

Intel Galileo-Arduino

Engineering sample hits E-Labs desk

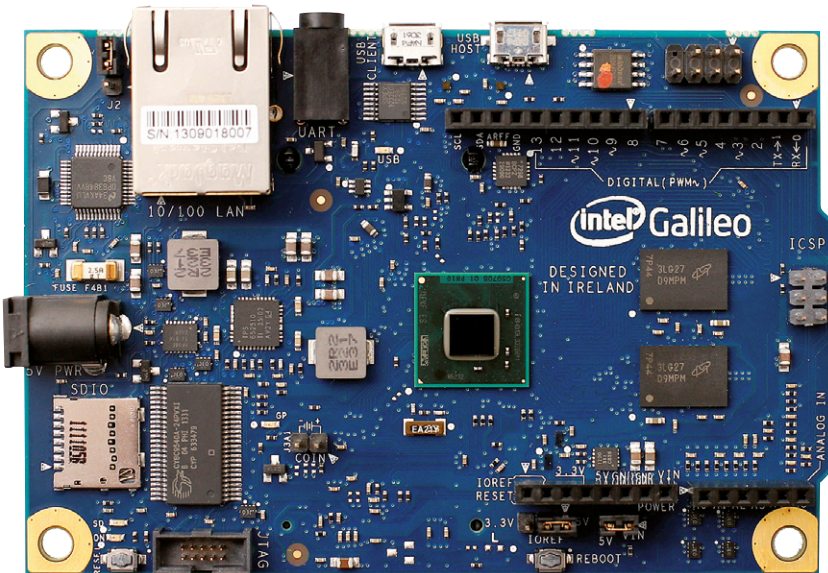

By **Thijs Beckers** (Elektor Labs)

One of the privileges of working at a publishing house is that you get sneak previews of things in manufacturers' pipelines. Recently we were delighted to have a look at the new Galileo-Arduino. Here's some *intel* on a new board.

The Intel Galileo is a co-production between Ivrea, Italy-based Arduino and big-gun chipmaker Intel Corporation. Arduino's new *Arduino Certified* family starts off with the Intel Galileo board and is supposed to address beginners and *next level* developers. With a 400-MHz 32-bit Intel Pentium® instruction set architecture compatible processor, the latter group seems to identify the target market better than the former. But let's have a quick look at the engineering sample on our desk.

Looking at the type, appearance and sheer amount of electronic components, this Arduino family member sure looks like the Big Daddy of them all. Compared to the Uno it plays in a far higher league and even the Yún doesn't seem to come close. Besides the standard Arduino pin-header configuration, we see a lot of other I/O, like a JTAG interface, an ICSP header, RS-232, and a USB client as well as a USB host interface. And of course an RJ-45 network port.

The prominent Intel chip is flanked by two Micron MT41K128M8JP-125:G 1-Gbit DDR3L memory chips. The ample amount of 0402-shaped capacitors and resistors are all accounted for in the fairly large schematic circuit, which—as customary with all Arduino boards—is available for downloading [1] and comprises a whopping 27 pages! BTW, the 3.5-mm audio connector is not used for audio, but rather represents the legacy RS-232 interface.

After unpacking, reading the Quick Start Guide and downloading the development tools from Intel [2]—we used Intel Galileo Arduino SW v1.5.3 for Windows v07.5—we unzipped the software and copied it to the root of our hard drive, as suggested in said guide. Using a different location could result in errors due to path length problems. And it did after we tried to run it from a different location.

The power supply must be connected prior to the USB cable. Otherwise the board might get damaged. The included wall wart is rated at a hefty 5 V, 1.5 amps, which suggests this Arduino matriarch is quite power hungry. After the client USB port on the Galileo is connected to your PC or Mac, the driver installation process begins. Following the instructions from the Getting Started

[1] <http://arduino.cc/en/ArduinoCertified/IntelGalileo>

[2] <https://communities.intel.com/community/makers/software/drivers>

Guide ensures the correct installation of the drivers. Now the Intel Galileo pops up as an extra port in the computer management. We need to remember the COM port number, as we'll have to enter it in the Arduino IDE.

Now we can run the Arduino IDE, load an Arduino Sketch and start what we set out to accomplish with this new Arduino Galileo board. The Getting Started Guide starts off with the *Blink* sketch. Following this suggestion produces the well-known, straightforward way to program an Arduino board. First select the Board and Serial Port from the *Tools* menu. Then, after hitting the Upload button, the little green LED marked GP (General Purpose?) starts blinking every second. It's not too bright though, as it is only a 0603 shape LED, but it suits its purpose. That was easy!

The Getting Started Guide suggests updating the board's firmware using the release-specific firmware included in the IDE, which shouldn't take longer than 15 minutes. So make sure your board is up to date before you start developing. The Galileo is able to boot from an SD card. In the short time available for this review we didn't try this, but we did try the *ReadAnalogVoltage* sketch, which seems to work well, faithfully returning the measured voltage on analog input A0 via USB to the built-in Serial Monitor (available under the *Tools* tab in Arduino IDE).

Using Wi-Fi capabilities of the board mandates booting from an SD card, as there is too little storage available in the on-board SPI flash to incorporate the Wi-Fi driver. Hence we didn't get to test that, but the Wi-Fi adapter socket on the back of the board wasn't populated anyway. The Release Notes state that the Integrated Wi-Fi functionality was validated with an Intel Centrino Wireless-N 135 adapter—an optional module that can be acquired separately.

Our final thoughts? It is natural for electronics to evolve and become more sophisticated with every new generation, but the Arduino Certified Intel Galileo sure is a giant leap ahead of the 'familiar' Arduino products. Will it play as big a role in Arduino's (r)evolution as its namesake Galileo Galilei did for the Scientific Revolution? Who knows. Maybe it evolved past its current target audience and will prove to be too difficult for the Arduino community? That's something we'll probably find out over the course of this year, when the board gets released officially.

(130449)

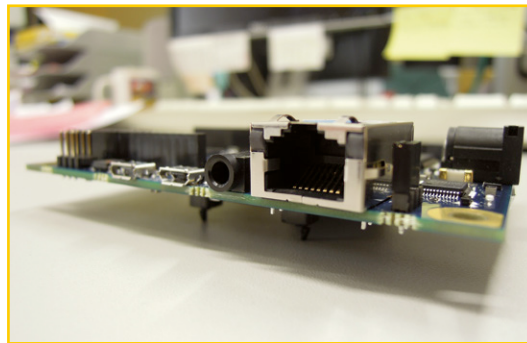

Download the free Galileo-Arduino Poster, exclusive for Elektor Post and Elektor Magazine readers, courtesy of Mouser & Elektor! Limited period: February 21 – March 5, 2014. Get it at: www.elektor.com/galileo-arduino

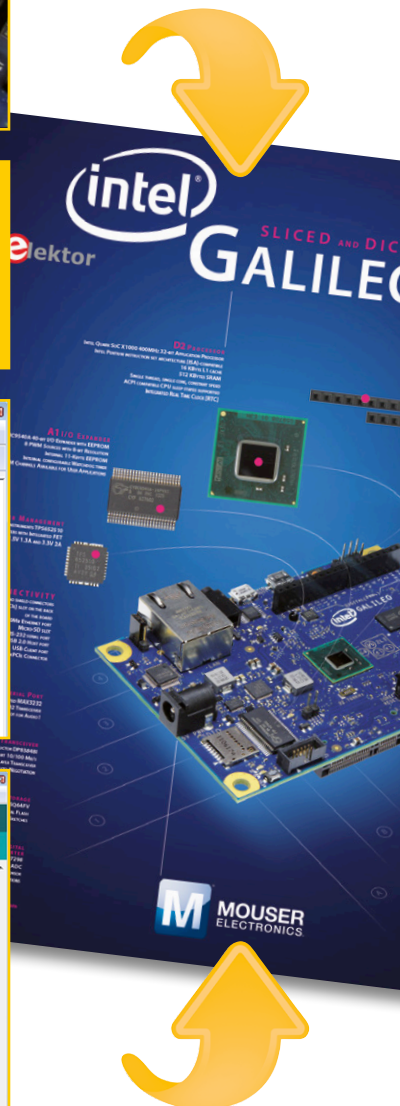
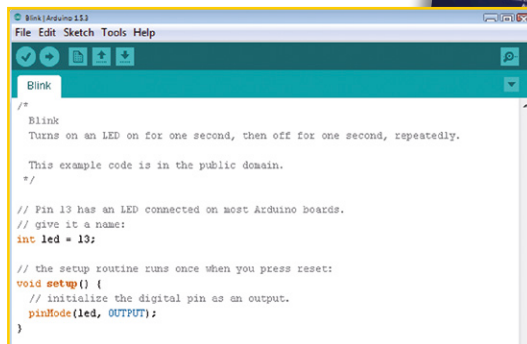
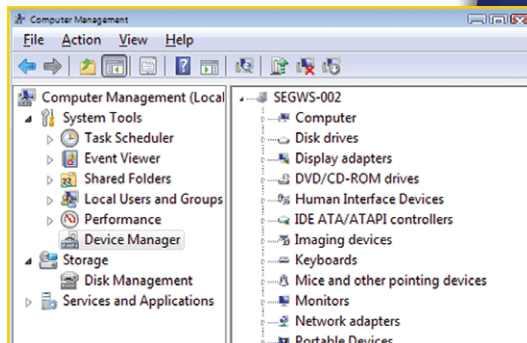

PCB real estate 'transformed'

By **Thijs Beckers**
(Elektor Labs)

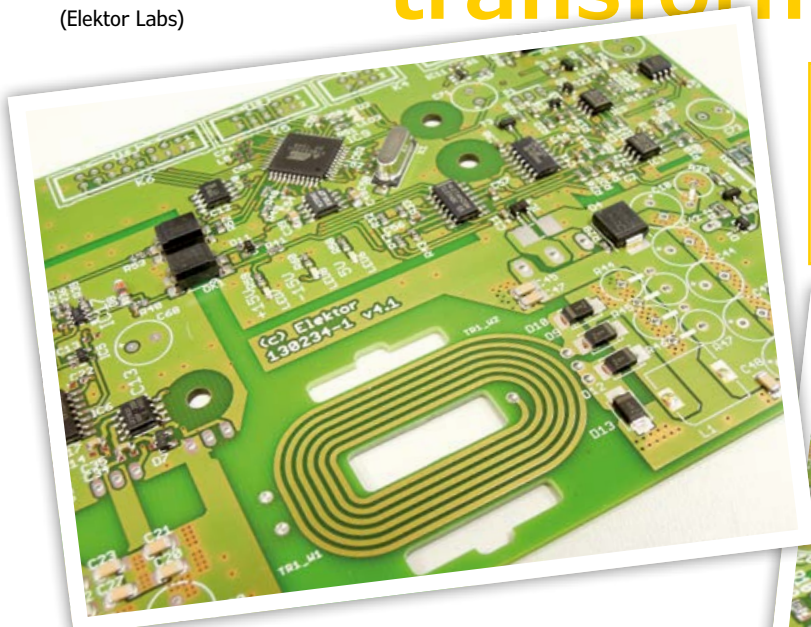

Preliminary, Tentative Specifications:

- PC PSU supplies raw 12-V input
- Output voltage adjustable from 0 to 30 V
- Power output 30 watts max.

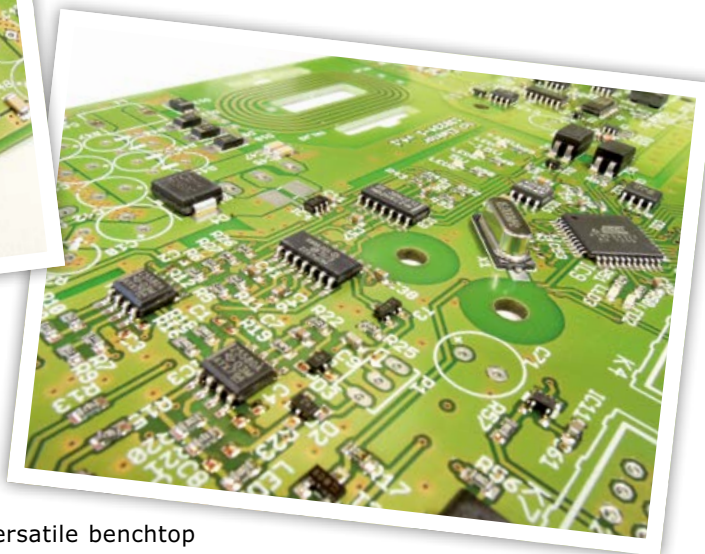

A power supply was born at Elektor Labs. Arne Hinz has spent his time as an Elektor Labs trainee well, designing a versatile benchtop power supply with the output electrically isolated from the AC power outlet based on a design by Martin Christoph at ISEA, RWTH Aachen, Germany.



His design incorporates an interesting implementation where the essential step-up transformer is designed 'in-board' as proposed by Christoph. The input voltage is stepped up using a switch-mode regulator and this 'PCB transformer' to supply a voltage for the output circuit.

Two 7-segment displays show voltage and current, which are set using two encoders. We cannot reveal all the details for the circuit at this point, but we do have some photographs to show you and whet your appetite.

(130363)



IoT ASIA 21-22
APRIL 2014

ASIA'S PREMIER
INTERNET OF THINGS & M2M
CONFERENCE & EXHIBITION

Singapore Expo Convention & Exhibition Centre

**Showcase Your Products And
Solutions To Asian End-Businesses Ready
To Adopt IoT/M2M**



For more information:

www.internetofthingsasia.com | info@internetofthingsasia.com

Organised By



Founding Members



Nikkei Business Publications, Inc.



Supported By



Co-Located Conference



Silver Sponsors



Supporting Partner



Association Partners



Knowledge Partner

Strategic Partner



Supporting Media Partner





DesignSpark Tips & Tricks

Day #8: Custom Board Outlines

By Neil Gruending (Canada)

In the previous *DesignSpark T&T* articles I used a square board outline because it was easy to draw. Today we will create a board outline for a Hammond Manufacturing 1551N enclosure using DesignSpark Mechanical and then import it into DesignSpark PCB.

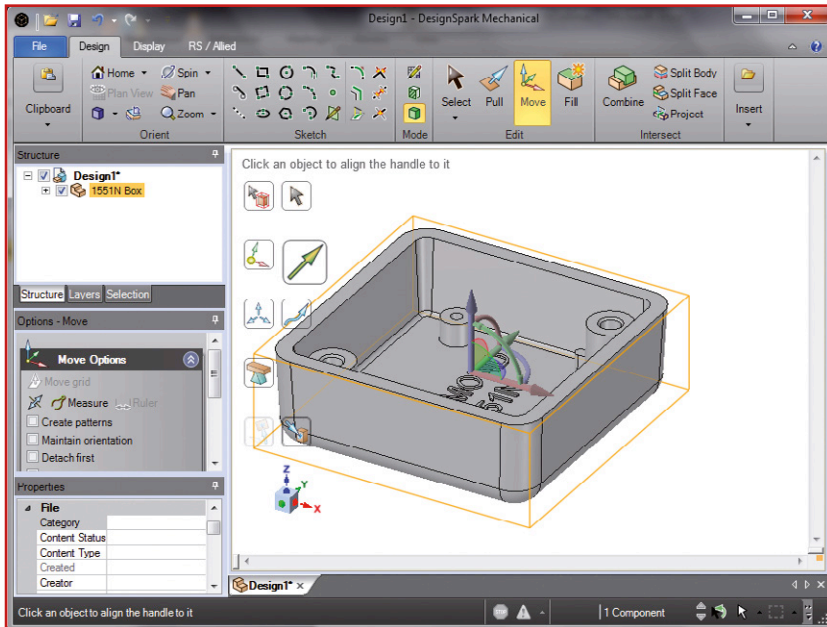

Figure 1. Finished importing the STEP files for the Hammond 1551N case into DesignSpark.

The 1551N PDF design file from Hammond includes a board outline drawing already [1] but we'll use the STEP files to make our own outline instead using the DesignSpark Mechanical PCB outline tutorial [2].

Creating the PCB Outline

The first step is to import the enclosure STEP files into your DesignSpark Mechanical project by clicking the Design→Insert→File toolbar icon. The File Open dialog window will open which will let you select the file you want to import into the design. By default the dialog will only show DesignSpark Mechanical Design files (*.rsdoc) so select STEP files (*.step) to display our enclosure model files. This is what the enclosure model will look like after importing it—see **Figure 1**. After following the cross section instructions in the DesignSpark tutorial the enclosure should look like the one you see in **Figure 2**.

Figure 2. DesignSpark Mechanical creates a cross-sectional view of the enclosure.

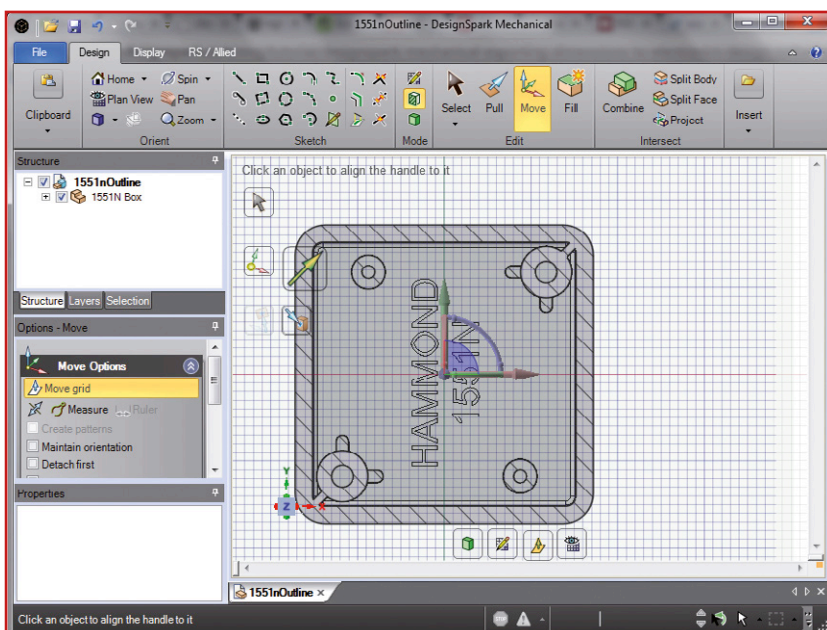

The small mounting bosses are used to attach the circuit board and the larger ones are used for the lid. The next step is to create a 2D drawing of the enclosure at the mounting boss height. The DesignSpark tutorial tells you how to create a new component for the PCB outline and then tells you to block select the PCB area while in “Project to sketch” mode. It's very important that after you

create the PCB outline component that you make the project (in this case 1551nOutline) the active component by right clicking on it and selecting "Activate Component". The selection process in the next step will only select edges and faces in the active component hierarchy so if you forget to make the entire design active you won't be able to select anything in subsequent steps.

When the DesignSpark tutorial tells you to block select the PCB area it means that you should click and drag a box that will enclose the entire interior of the enclosure where the PCB will fit. I did this by clicking in the middle of the upper left edge corner wall and dragging to the middle of the lower right corner wall. This will select all of the edges and points from the design and make them available in the sketch plane which in this case is where our PCB will touch the mounting bosses. Do this step in "Plan View" because DesignSpark Mechanical will give you different results if you select the plane in a 3D view. Once the area is selected you'll see a "Curves" component added to the design which you can then click on and drag to the PCB outline component as explained in the tutorial.

At this point you should be able to open the PCB outline component by right clicking on it and selecting "Open Component". You might have to save and reopen the design file if the "Open Component" option is greyed out. When you open the PCB outline it will be a 2D representation of the PCB area but it will also include all of the edges and faces from the top to the bottom of the enclosure which adds many more lines that you might expect. One good trick is to open the 3D model and find where the PCB area view intersects with the enclosure walls and double click that line to change its color to something obvious. Fortunately changing the color in the 3D view will also change the line color in the PCB outline model like in **Figure 3**.

Here the green line shows the actual PCB outline plane and it makes it easy to distinguish it from the other lines in the PCB outline view.

Now we have to edit the outline view to only include the PCB outline area which means deleting most of the non-green lines. You do this by using the "Trim Away" tool and by deleting unneeded lines. Use the trim tool to modify lines (if you hover

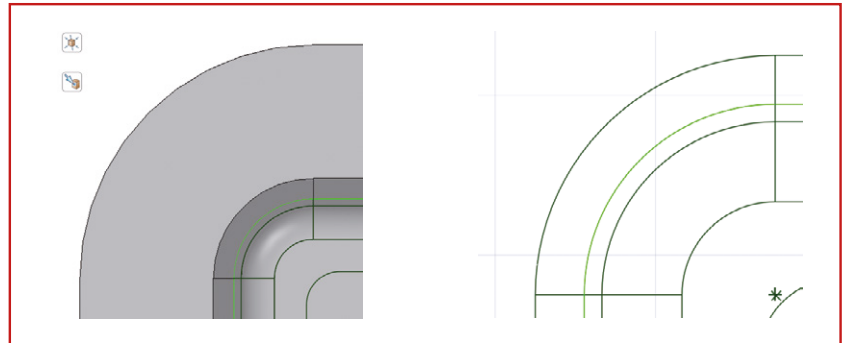

Figure 3. The green helper line conveniently marks the PCB outline.

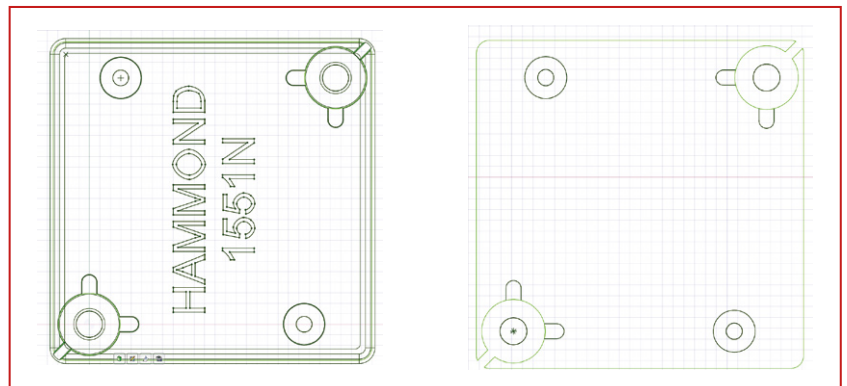

Figure 4. The raw image (left) is trimmed and eventually yields the 'net' version of the case bottom (right).

over a line it will highlight the segment it would delete if you click). Otherwise you can block select areas and delete them. I personally found that block selecting areas worked better in 3D mode than in "Plan View". The right image in **Figure 4** shows the edited version of the left image.

Note that I left all of the bosses and mounting tabs in place because we still need to edit the outline to an appropriate shape to avoid the large lid mounting bosses and to allow for manufacturing tolerances between the enclosure wall and PCB. I chose to use 0.4445 mm between the PCB and enclosure wall to give an overall board dimension of 29.5 mm square. First I made the PCB square by using the "Create Corner" tool and then deleted all of the rounded corners. This makes it easier to modify the outline because DesignSpark doesn't have to try and keep the curved corners connected. I then used the move tool to move each side of the PCB 0.4445 mm

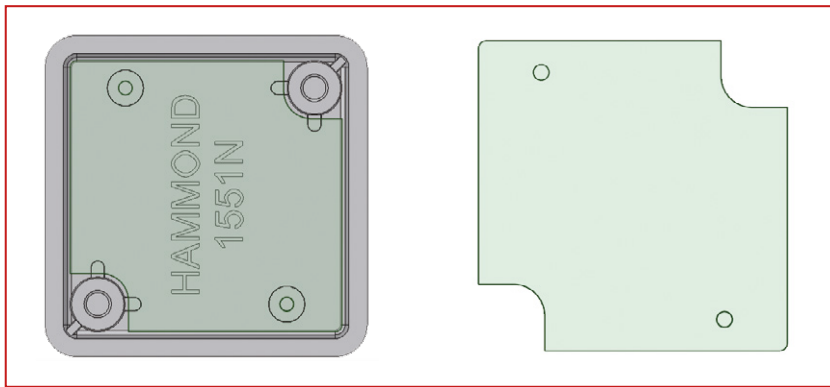

Figure 5. Creating rounded PCB corners is a walk in the park.

inwards by using the space bar while moving the line to let me enter the exact dimension I wanted. Next I drew 6.34 mm squares in the lower left and upper right corners around the lid mounting bosses. Once that was done I used the trim tool to remove all of the extra lines I didn't want and then used the "Create Rounded Corner" tool to create the rounded corners. **Figure 5** shows my end result (in and out of the enclosure).

Now we need to save the PCB outline as a DXF file so that we can import into DesignSpark PCB. You do this by going into "File→Save As" menu from the PCB outline component window and selecting DXF format.

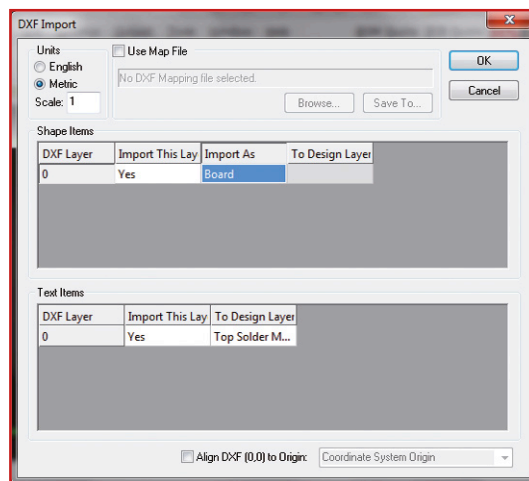

Figure 6. The PCB outline gets imported back into DesignSpark PCB.

Import outline

Now that we've created our PCB outline let's import it into DesignSpark PCB. Create a new PCB file and then go into the File→Import menu. After you choose the DXF file you will see the DXF Import window (**Figure 6**). Select metric units and change the "Import As" field to "Board". After you press ok you will get the board outline with the mounting holes in the wrong places but we'll fix that next time. It will look as pictured in **Figure 7**.

Conclusion

So far we've managed to create a custom PCB outline in DesignSpark PCB even though the mounting holes didn't import correctly. Next time we'll fix the mounting holes and add keepout areas for the mounting bosses.

(130360)

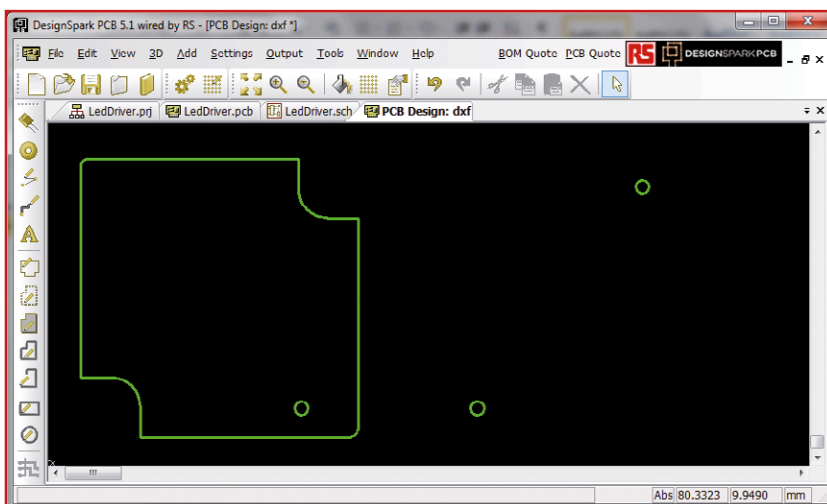

Figure 7. Board outline with rounded corners ready for further design work in DesignSpark PCB. Don't worry, the two orphan holes will be moved to the correct positions inside the board next time.

Web Links

- [1] Hammond 1551N case design data: www.hammondmfg.com/dwg9.htm
- [2] DesignSpark Mechanical exporting tutorial: www.designspark.com/eng/tutorial/designspark-mechanical-exporting-dimensions-to-electronics-design-software.

engineering electronics
 DISCUSS **embedded**
 design tips tutorial software
 engage **engineering** tools
 contests system **audio** business
 data **networking** **media**
 COMMUNITY **mobile**
social media talk
 information product news
 projects

Want to talk to us directly?
 Share your interests and opinions!
 Check out our New Social Media
 Outlets for direct engagement!



CIRCUIT CELLAR / AUDIOXPRESS / ELEKTOR



PTC Fuses

Weird Component # 3

By
Neil Gruending
(Canada)

It's very common to see fuses used for overcurrent protection in electronics but they can only protect a circuit once and then they need to be replaced. That works well when the overcurrent event is rare but what if the event could happen often enough that replacing the fuse isn't practical?

What you really need is a resettable fuse like a Positive Temperature Coefficient (PTC) fuse. But what makes PTC fuses really interesting is that

they automatically reset themselves once the overcurrent condition is removed.

But how can a PTC fuse reset itself? A PTC fuse uses a polymer that will act as a low value resistor under normal operating conditions but an overcurrent condition will heat up the polymer and make it go into a high resistance state. When the load returns to a normal state the polymer cools down which resets the fuse. The polymer element is what defines the PTC fuse voltage and current ratings.

Because a PTC fuse can reset itself it can do more than behave like fuse. One example is protecting a power supply from line transients when used with a transient voltage suppressor (TVS) diode. The PTC fuse will be in its low impedance state as long as the input voltage is less than the TVS clamp voltage. But when the input voltage goes high enough for the TVS to conduct then the PTC fuse will trip and go high impedance which disconnects the power supply from the input line until the input voltage returns to normal. The TVS will usually conduct for the entire voltage transient because the PTC fuse has a small leakage current while it's in its high impedance state. This type of circuit is common in automotive applications.

Another example is protecting an amplifier output from being overloaded. For this type of protection you would use a PTC fuse in parallel with a high value power resistor like 10 kΩ. Under normal conditions the PTC fuse shorts out the power resistor so that the total resistance is several ohms. If the output load increases to the point that makes the PTC trip then power resistor will be active and reduce the output power applied to

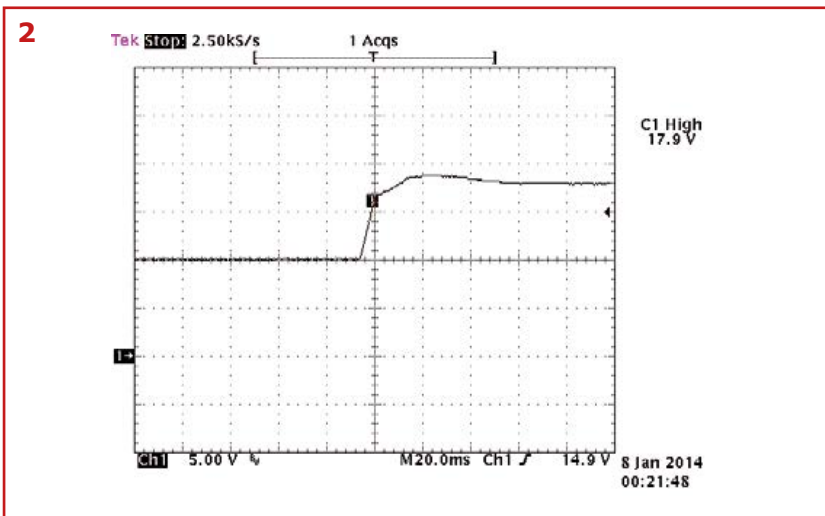

the load. Here again the small PTC fuse leakage current will keep it in equilibrium until the fault is removed. This type of circuit is typically used in audio amplifier speaker outputs.

PTC fuses are also pretty easy to use. The key parameters to worry about are the holding and trip current. The holding current is the recommended maximum operating current at a specific ambient temperature. Higher currents may cause the PTC to start increase its resistance. The trip current is the overload current that will trip the PTC fuse in a specified amount of time. If the current is between the holding current and the trip current the fuse may still trip but it could take a long time before the fuse will trip just like a conventional fuse. It's also important to remember that the hold and trip currents can vary a lot over ambient temperature because they are heat sensitive. For example a typical PTC fuse can have a tol-

erance of $\pm 50\%$ over the temperature rate of -40°C to $+70^{\circ}\text{C}$.

Figure 1 shows an example of a power line transient protection circuit I tried on my bench. I wired up a 300-mA PTC fuse to a 16-V TVS so that we can see what happens when the input voltage changes from 10 V to 30 V. The oscilloscope shows a peak voltage of about 18 V and then the voltage remains clamped to 16 V as expected (**Figure 2**). But the really cool part is that the current consumption at 30 V was about 30 mA whereas without the PTC fuse the TVS diode would've overheated and failed. Returning the input voltage to 10 V resets the PTC fuse. Hopefully I've convinced you to add PTC fuses to your circuit protection arsenal. They are some of the most versatile protection devices around!

(130476)

Advertisement

Retronics 80 tales of electronics bygone

This book is a compilation of about 80 Retronics installments published in Elektor magazine between 2004 and 2012. The stories cover vintage test equipment, prehistoric computers, long forgotten components, and Elektor blockbuster projects, all aiming to make engineers smile, sit up, object, drool, or experience a whiff of nostalgia.

193 pages • ISBN 978-1-907920-18-9
£24.80 • €29.95 • US \$40.00

NOSTALGIA



Further information and ordering at www.elektor.com/retronics

SCOPE DEALS

6-IN-1 SCOPE

2-ch 2MSa/s 200kHz 11-bit oscilloscope, 2-ch spectrum analyzer, 2MSa/s 8-bit arbitrary waveform generator, function gen, network analyzer, PWM/Digital I/O. - CGM-101 **\$99.95**



PASSPORT-SIZE PC SCOPES

Great scopes for field use with laptops. Up to 200MHz bandwidth with 1GSa/s, high speed data streaming to 1MSa/s, built-in 1GSa/s AWG/wfm gen. - PS2200A **\$239+**



30MHz SCOPE

Remarkable 30MHz, 2-ch 250MS/s sample rate oscilloscope. 8-in color TFT-LCD and AutoScale function. Includes FREE carry case + 3 yr warranty! - SDS5032E **\$289**



60MHz SCOPE

Best selling 60MHz 2-ch scope with 500MSa/s rate • huge 10MSa memory! 8" color TFT-LCD. Includes FREE carry case! - SDS6062 **\$349**



100MHz SCOPE

High-end 100MHz 2-ch 1GSa/s benchscope with 1MSa memory and USB port • FREE scope carry case. New super low price! - DS1102E **\$399**



INCREDIBLE LOW PRICES, FREE TECHNICAL SUPPORT
EXCELLENT CUSTOMER SERVICE WWW.SAELIG.COM

Accelerate Firmware Development Time for Linear Technology ICs with the Linduino Platform

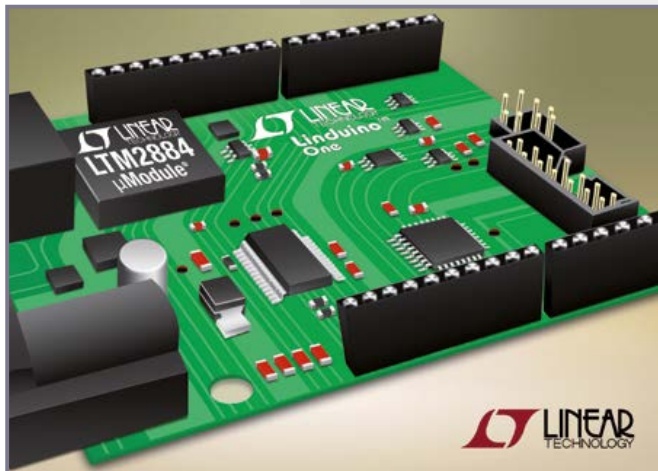

Linear Technology Corporation announces their Linduino™ One development tool, an Arduino-compatible platform for developing and distributing firmware libraries and code for Linear Technology's SPI and I²C-compatible integrated circuits. The Linduino One board interfaces to more than 300 QuikEval™ demonstration cards, supporting a variety of product types including analog-to-digital converters (ADCs), digital-to-analog converters (DACs), power monitors, intelligent Hot Swap™ controllers, temperature sensors, LED drivers, and battery management systems.

Firmware libraries for individual devices are written in C and designed to be portable to a wide variety of processors and microcontrollers. Each library has a demonstration program that can be uploaded to the Linduino One platform to allow the circuit and software to be quickly and easily verified. The free and open-source Arduino integrated development environment (IDE) compiles and loads the code into the Linduino

One platform, with no additional programming hardware required.

The Linduino One tool is galvanically isolated from the host PC by an LTM2884 USB transceiver with isolated power. This provides an added measure of safety in high voltage applications such as telecom power monitoring and battery monitoring, and breaks ground loops in precision, low-noise ADC and DAC applications.

The DC2026A Linduino One board is available as a stand-alone product or can be purchased as a DC2026A-kit, in combination with the DC934A, LTC2607 dual 16-bit I²C DAC and LTC2422 20-bit SPI ADC demonstration board. These demo kits can be purchased via Linear Technology's website or via our authorized Digi-Key, Newark, Farnell or Element14 distributors. Pricing begins at \$75.00 each for the DC2026A and \$125.00 each for the DC2026A kit.

www.linear.com/Linduino (130364-VIII)

Imaging Technology Helps Visually Impaired



STMicroelectronics announced that its 5.1 mega-pixel camera module and low-power digital image processor are being used in the revolutionary OrCam camera, a small device that clips on to eyeglasses and dramatically improves the mobility and ability of visually-impaired people to "read" signs, packaging and publications.

By pointing to an object, the wearer tells the OrCam camera what they need interpreted. The ST VX6953 camera module and STV0987 image processor work together to analyze and interpret the scene before the eye-glass-mounted device aurally describes it to the user. Using the ST technology and its own algorithms, the OrCam camera quickly reads a scene or text in different lighting conditions and on a variety of surfaces, including newspapers and signs. Moreover, while the camera comes with a pre-stored library of objects, the wearer can continue to teach OrCam new objects as they use it. OrCam can be ordered through the company's website.

www.orcam.com www.st.com (130364-IX)

M140 Mini Handheld Solar Power Meter



Anaheim Scientific recently introduced the fourth model in its M-Series of mini-handheld environmental meters: The M140 Mini Solar Power Meter.

The M-Series are small handheld meters that make taking measurements out in the field easy and convenient.

M140 Mini Solar Power Meter main technical features

- Units: W/m² or [BTU/(ft²*h)]
- Range: 1999 W/m² or 634 [BTU/(ft²*h)]
- Resolution: 0.1 W/m² or 0.1 [BTU/(ft²*h)]
- Accuracy: Typically within ±10 W/m² [±3 BTU/(ft²*h)] or ±5%, whichever is greater in sunlight

The M140 is priced at \$115.00.

Advertisement

\$51^{For 3} PCBs

FREE Layout Software!
FREE Schematic Software!

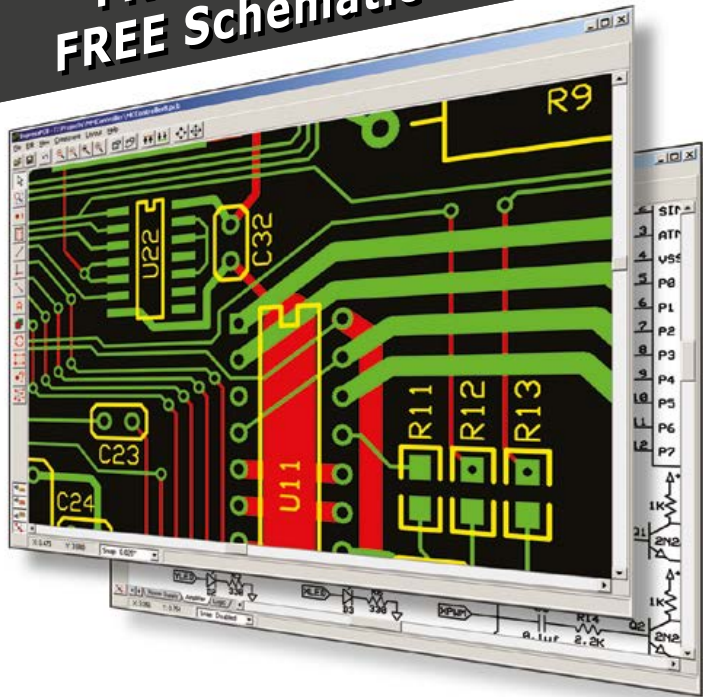

- 01 DOWNLOAD our free CAD software
- 02 DESIGN your two or four layer PC board
- 03 SEND us your design with just a click
- 04 RECEIVE top quality boards in just days

expresspcb.com

The M-Series meters have the following features in common: large 3¾ digit display; small 5.3 x 1.9 x 0.2 inch weighing only 2.8 oz (80 grams); Data hold; Maximum/Average/Minimum Hold; Zero adjustment; Low battery indicator; Auto power off and disable function; Light weight (less than 9 oz.); Powered by 2 x AAA batteries; Limited two-year warranty.

anaheimscientific.com/products (130364-III)

TrueTouch® Capacitive Touchscreen Controllers Support Fujifilm Metal Mesh Sensors

Cypress Semiconductor Corp. claims their metal mesh sensors deliver better scanning performance than traditional indium tin oxide (ITO) sensors, and they are easier to manufacture, cutting cost and design time. Unlike ITO, metal mesh sensors are bendable, allowing designers to use capacitive touch capability with flexible displays and curved surfaces. Cypress offers the CY3290-TMA500 and CYTK58 TrueTouch Evaluation Kits that enable customers



to design with Fujifilm metal mesh sensors and to leverage the industry-leading features of the TrueTouch portfolio.

Smartphone touchscreens are constantly evolving in terms of size, surface, shape, and performance. Manufacturing with metal mesh sensors enables lower cost phones to integrate capacitive touch technology. The technology improves touchscreen sensitivity and delivers robust noise immunity. Cypress has partnered with Fujifilm and other leading metal mesh vendors to make the technology accessible to its customers.

"Our metal mesh sensors provide the compelling alternative to ITO modules the market has been seeking," said Jun Ozawa, Senior Operations Manager, Industrial Products Division at Fujifilm. "We are working closely with Cypress and also other leading touch controller vendors, to help them bring the design flexibility, cost efficiency, and fast, precise scanning of our sensors to smartphones, tablets and other portable touchscreen devices."

"Supporting metal mesh sensors and working with innovative partners such as Fujifilm is a perfect example of how the TrueTouch team looks for new ways to provide more value and more design options to our OEM customers," said John Carey, Senior Director of TrueTouch Marketing at Cypress. "We are excited to see the unique, next-generation products our customers will bring to market with the combination of metal mesh sensors and the best-in-class features of our TrueTouch portfolio, especially our leading-edge Gen5 family."

www.cypress.com (130448-I)

8-Port RS-422/485 Serial Interface for PCI Express

Sealevel Systems announces the 7802e, a new PCI Express serial interface adapter that provides eight serial ports individually configurable for RS-422 or RS-485 communications. For error-free operation in high-speed serial applications, the board's high-performance 16C950 UART includes 128-byte FIFOs, eight times larger than those found on standard 16550 UARTs. Additionally, the 16C950 UART supports 9-bit framing and is fully software compatible with legacy UART applications. The 7802e is ideal for a variety of applications including test and measurement, security systems, and broadcast.

The 7802e derives a 62.5 MHz clock from the PCI Express link. This ultra-high speed clock is divided by a flexible 8-bit clock prescaler with 1/8 steps to provide support for the widest range of standard and non-standard baud rates. In RS-485 mode, the transmitter is automatically enabled in hardware, eliminating the need

for application software control. This allows the 7802e to be used with standard serial applications while removing the risk of bus contention and data corruption.

All Sealevel PCI Express serial adapters include SeaCOM software for Windows and Linux operating systems. As an added value, customers also receive WinSSD, a full-featured application for testing and diagnostics including BERT (Bit Error Rate Testing), throughput monitoring, loopback tests, and test pattern message transmissions. The 7802e is available immediately from stock priced at \$469 for low profile (Item# 7802e) and standard size (Item# 7802eS) PCI Express slots. Both items ship with a 36 inch cable that terminates to eight DB9M connectors. Standard operating temperature range for is 0 to +70°C (extended temperature versions operating from -40°C to +85°C are available). Like all Sealevel I/O products, the 7802e is backed by a lifetime warranty.

www.sealevel.com (130448-V)

Arduino

Now Available @ Elektor!

10% OFF for
GREEN and
GOLD Members

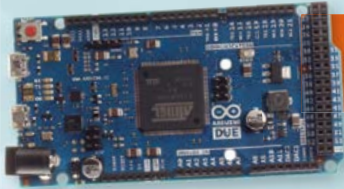

ARDUINO DUE

32-bit power thanks to an ARM processor

Features	
Microcontroller	AT91SAM3X8E
Operating Voltage	3.3V
Input Voltage (recommended)	7-12V
Input Voltage (limits)	6-20V
Digital I/O Pins	54 (of which 12 provide PWM output)
PWM Channels	12
Analog Input Pins	12
Analog Outputs Pins	2 (DAC)
DC Current per I/O Pin	130 mA
DC Current for 3.3V Pin	800 mA
DC Current for 5V Pin	800 mA
Flash Memory	512 KB (all available for the user applications)
SRAM	96 KB (two banks: 64KB and 32KB)
Clock Speed	84 MHz

£47.00 • € 52.77 • US \$76.50



ARDUINO MEGA

Like the Uno but with more memory and I/O

Features	
Microcontroller	ATmega2560
Operating Voltage	5V
Input Voltage (recommended)	7-12V
Input Voltage (limits)	6-20V
Digital I/O Pins	54 (of which 15 provide PWM output)
Analog Input Pins	16
DC Current per I/O Pin	40 mA
DC Current for 3.3V Pin	50 mA
Flash Memory	256 KB (of which 8 KB used by bootloader)
SRAM	8 KB
EEPROM	4 KB
Clock Speed	16 MHz

£47.00 • € 52.77 • US \$76.50



ARDUINO LEONARDO

Especially good for USB applications

Features	
Microcontroller	ATmega32u4
Operating Voltage	5V
Input Voltage (recommended)	7-12V
Input Voltage (limits)	6-20V
Digital I/O Pins	20 (of which 7 provide PWM output)
PWM Channels	7
Analog Input Pins	12
DC Current per I/O Pin	40 mA
DC Current for 3.3V Pin	50 mA
Flash Memory	32 KB (of which 4 KB used by bootloader)
SRAM	2.5 KB
EEPROM	1 KB
Clock Speed	16 MHz

£22.10 • € 24.81 • US \$36.00



ARDUINO UNO

The most popular board with its ATmega328 MCU

Features	
Microcontroller	ATmega328
Operating Voltage	5V
Input Voltage (recommended)	7-12V
Input Voltage (limits)	6-20V
Digital I/O Pins	14 (of which 6 provide PWM output)
PWM Channels	6
Analog Input Pins	6
DC Current per I/O Pin	40 mA
DC Current for 3.3V Pin	50 mA
Flash Memory	32 KB (of which 0.5 KB used by bootloader)
SRAM	2 KB
EEPROM	1 KB
Clock Speed	16 MHz

£24.40 • € 27.35 • US \$39.70



ARDUINO ETHERNET

Networking has never been easier

Features	
Microcontroller	ATmega328
Operating Voltage	5V
Input Voltage (recommended)	7-12V
Input Voltage (limits)	6-20V
Digital I/O Pins	14 (of which 4 provide PWM output)
Arduino Pins reserved	10 to 13 used for SPI 4 used for SD card 2 W5100 interrupt (when bridged)
Analog Input Pins	6
DC Current per I/O Pin	40 mA
DC Current for 3.3V Pin	50 mA
Flash Memory	32 KB (of which 0.5 KB used by bootloader)
SRAM	2 KB
EEPROM	1 KB
Clock Speed	16 MHz

£48.10 • € 53.98 • US \$78.30



ARDUINO YÚN

Two processors

Features AVR Arduino microcontroller	
Microcontroller	ATmega32u4
Operating Voltage	5V
Input Voltage	5V
Digital I/O Pins	20
PWM Channels	7
Analog Input Channels	12
DC Current per I/O Pin	40 mA
DC Current for 3.3V Pin	50 mA
Flash Memory	32 KB (of which 4 KB used by bootloader)
SRAM	2.5 KB
EEPROM	1 KB
Clock Speed	16 MHz
Features Linux microprocessor	
Processor	Atheros AR9331
Architecture	MIPS @400 MHz
Operating Voltage	3.3V
Ethernet	IEEE 802.3 10/100Mbit/s
WiFi	IEEE 802.11b/g/n
USB Type-A	2.0 Host/Device
Card Reader	Micro-SD only
RAM	64 MB DDR2
Flash Memory	16 MB
PoE compatible 802.3af card support	

£62.30 • € 69.95 • US \$101.40



Further Information and Ordering at www.elektor.com/arduino

Hewlett Packard Model 200AB Audio Oscillator

A worthy descendant of the 200A

By
Chuck Hansen
(USA)

The story of the Hewlett-Packard Corporation began back in 1939, when William Hewlett used a tungsten filament lamp in a vacuum tube Wien Bridge oscillator circuit. The light bulb provided the variable temperature coefficient resistance needed to keep the oscillator output voltage sta-

ble, while not adversely affecting the distortion. Hewlett partnered with David Packard to produce their first commercial product, the 200A Audio Oscillator (**Figure 1**). The HP 100A through 100E were crystal-controlled frequency standards, and were targeted towards calibration and scientific laboratories, so I guess they weren't considered "commercial" products. The HP 20x-series was assigned to variable frequency oscillators.

The Model 200A produced 1 watt ($22.4 V_{\text{rms}}$) into 500Ω over a frequency range of 35 to 35,000 cps (cycles per second; Hz). The sheet metal chassis measured 267 mm W \times 178 mm H \times 254 mm D. You can read more about the history of Hewlett-Packard at the HP Virtual Museum web site at [1].

Walt Disney Studios asked H-P to make some design modifications to the Model 200 in order to test the audio systems in specially-equipped theaters that would show the Disney movie *Fantasia* in 1940. This modification became the HP 200B. It produced 1 watt into 500Ω over a frequency range of 20 to 20,000 cps.

The HP 200C was similar to Model 200A but its audio amplifier uses two R-C coupled tube stages instead of the output transformer used in Models 200A and 200B. The Model 200C had an extended upper frequency range of 200 kcps but its output was only 100 milliwatts into 1000 Ω .

The Model 200I was a spread-band oscillator with a range of 6 cps to 6 kcps, and an R-C coupled output of $10 V_{\text{rms}}$ into 1000 Ω . The "I" in the model number meant Interpolation, since the frequency dial had 750 calibrated points over 300 degrees.

The Model 200AB and Model 200CD were introduced together in 1952. The cabinets for these models were also redesigned from low and wide to tall and narrow (191 mm W \times 292 mm H \times 318 mm D) to reduce their lab bench footprint. The frequency tuning dial was increased from about 5 inches to 6 inches diameter (**Figure 2**). The Model 200AB had a better output transformer with a frequency range of 20 to 40 kcps, and an output of 1 W ($24.5 V_{\text{rms}}$) into 600 Ω , superseded-



Figure 1.
HP 200A Audio Oscillator.
If you have one, call your
insurance company.



Figure 2.
HP 200AB Sine Oscillator
(ca. 1952).

EST^d 2004

Retronics is a monthly section covering vintage electronics including legendary Elektor designs. Contributions, suggestions and requests are welcome; please telegraph editor@elektor.com

ing both the Model 200A and 200B for the same price. THD was listed as <1% up to 20 kcps and <2% from 20 kcps – 40 kcps.

The Model 200CD had a much wider frequency range, 5 to 600 kcps, but a more limited output of 160 mW (9.8 V_{rms}) into 600 Ω.

The Model 201C had a frequency range of 20 to 20 kcps, and an increased output of 3 W (42.4 V_{rms}) into 600 Ω. THD was listed as <0.5% at 1 W and <1% maximum at 3 W. It also had a 0 to 40 dB stepped attenuator with 10 dB steps, and coarse and fine amplitude controls. The 200AB and 200CD models had a chassis ground jack (black) with a removable ground link to the low side output jack. This jack and link were deleted from the 201C.

The first HP solid-state oscillators

The next iteration of HP sine oscillators was the all-solid-state Models 204C and 204D. The chassis was reduced in size to 130 mm W × 155 mm H × 203 mm D (**Figure 3**). The 204C had a frequency range of 5 Hz to 1.2 MHz, with an output of 10 mW (2.5 V_{rms} into 600 Ω). A JFET was used for the stability dynamic resistance instead of the filament lamp used in the 200 series. THD was 0.5% from 100 Hz to 300 kHz, and 1% from 300 kHz to 1.2 MHz. Two battery power options were also available; a mercury battery pack or a NiCd rechargeable battery pack.

There were two ranges of low-frequency distortion from 5 Hz to 100 Hz, selected by means of a slide switch on the rear panel. The Low Distortion mode THD was 1%, while the Normal mode THD was up to 5%, but settled into a stable output much faster. Whenever I try to adjust the frequency too fast in Low Distortion mode of my 204C, the output becomes unstable.

The 204D was identical to the 204C except the amplitude output pot was replaced by a 0 – 80 dB stepped attenuator along with a >10 dB output vernier pot. A separate 0 – 110 dB passive 600-Ω stepped attenuator became available in the same sized chassis as the HP 350D. It could handle 5 watts of power (55 V_{rms}).

The HP 209A simultaneously provided both sine and square wave outputs, and had an extended frequency range of 4 Hz to 2 MHz. Sine wave THD was identical to the 204C/D up to 1 MHz. Above 1 MHz it increased to 5%.

HP 200AB—a closer look

Just remove two Phillips head screws above the rear panel power cord opening and you can slide

off the chassis cover. My 200AB is very clean inside and appears to have all its original tubes. The top view (**Figure 4**) shows the four-gang frequency tuning capacitor, which has an integral reduction gear to make precise tuning easier. **Figure 5** shows the oscillator section in the left

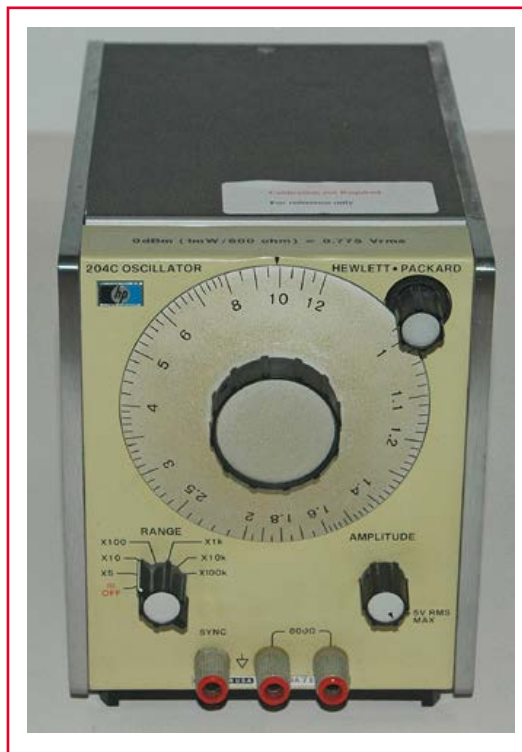

Figure 3. HP 204C Sine Oscillator.

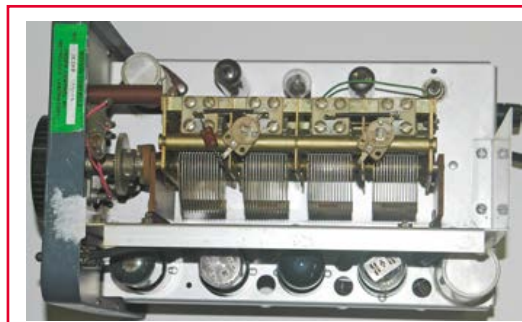

Figure 4. Top interior view of HP 200AB.

HP 200AB Electrical Tests

I use my HP 200AB audio oscillator when I need a higher output sine wave than my op amp-based oscillators and HP 339A distortion test set can give me. It still works really well. I ran some audio measurements on my HP 200AB oscillator.

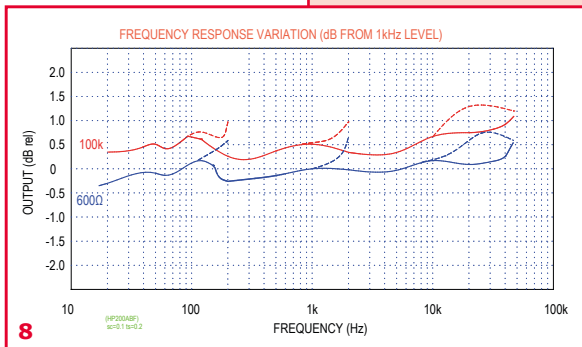
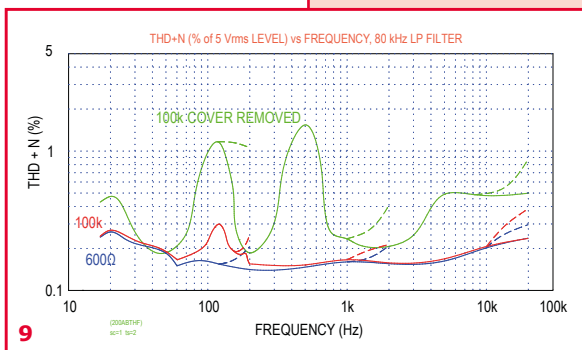

Figure 8 shows the frequency response with 100-k Ω and 600- Ω loads at 5 V_{rms} output (about 20 on the 0-100 AMPLITUDE control). The 20 and 200 frequency values overlap in the sense that you can set the same frequency at the extreme ends of the dial by changing the RANGE switch, i.e. 2 kHz can be set with 20 \times 100, or 200 \times 10. The rising dashed curves at 200 Hz, 2 kHz and 20 kHz represent where the 200 end of the frequency dial was used. You can see that in every case the output voltage increase at the 200 end of the dial, but stayed reasonably flat at the 20 end of the dial for the same frequency. The 200AB easily meets its specified ± 1 dB frequency response referenced to 1 kHz at rated output.



The output load affects the amplitude as expected. The specified output impedance is 75 Ω minimum. Using the 600- Ω and 100-k Ω output voltage values I calculated the internal impedance of my HP 200AB to be 38.5 Ω at 1 kHz, and it varies just ± 1 Ω over the entire frequency range. Over all the load, frequency and output testing I performed, I did not see R11 lamp illuminate at any time. The output sine wave showed no signs of clipping at any amplitude setting.

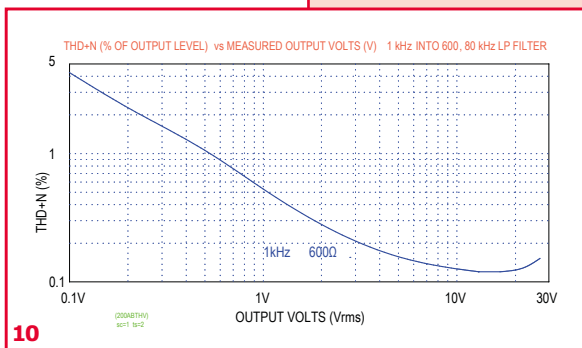

Figure 9 shows the THD+N vs. frequency for 100-k Ω and 600- Ω loads, again at 5 V_{rms} output. The 600- Ω graph is commendably flat, with a slight dip at 60 Hz where the HP 339A distortion test set notch filter removes the AC line component as well as the oscillator fundamental. I used my oscilloscope to review the Monitor output, after the distortion test set notch filter. It shows predominantly the 3rd harmonic over the entire frequency range. When the output is open-circuit except for the 100-k Ω distortion test set input load, the distortion shows a couple of peaks at 120 Hz and 180 Hz. While I was doing my initial testing on the HP 200AB, I removed the aluminum cover in order to access the R10 oscillator amplitude trim pot. Clearly, the cover is an integral part of the shielding system. The THD+N increased beyond the specified ± 1 dB limit with the cover removed. The HP 200AB uses megohms and picofarads in the Wien bridge section of the oscillator, so it does not take much extraneous interference to disrupt the oscillator.

The rising dashed curves again show the test points where I used the 200 end of the frequency dial. The increase in amplitude (Figure 8) is accompanied by a corresponding increase in distortion.

In **Figure 10** the test range is 100 mV to 27.7 V_{rms} , the maximum output of my HP 200AB at 1 kHz. The noise portion of THD+N decreases linearly from the lowest output voltage to 13 to 16.9 V_{rms} where the THD+N is just 0.12%. Above 17 V_{rms} it begins to rise again where the distortion products exceed the fixed noise level.

The amplifier output noise level with the AMPLITUDE control at zero is 4.62 mV $_{rms}$, or 74.5 dB below the rated 1 W output (24.5 V_{rms} into 600 Ω). This is quite impressive given the age of this HP 200AB, since the specified limit is 66 dB min. below rated output.

interior view. Tubes V1 (6AU6A) and V2 (6AQ5) have the small "hp" logo and MADE BY GENERAL ELECTRIC notation on the glass envelopes. Earlier units used octal tubes, 6SJ7 for V1 and another 6K6 as V2. Unlike the passive parts, the *Table of Replaceable Parts* in Section V of the HP 200AB manual does not require any specific tube vendor. The manufacturer designation is "ZZ", meaning any brand tube meeting RETMA standards [2]. A G.E. 10-W 240-V filament lamp (called "R11" on the schematic) is located between the two tubes. I've seen other 200-series oscillators with two 3-W 120-V filament lamps connected in series. The THD adjust pot is inside, at the rear of the chassis, and a Sprague 20- μ F 450-VDC coupling cap can (C8) is at the front. The Range rotary switch is located at the lower front of the unit, with large 1% tolerance Electra EKC carbon film resistors on the front wafer and smaller carbon composition trimming resistors on the rear wafer. The power cord and fuse holder are on the rear.

Figure 6 shows the amplifier and power supply sections in the right inside view. The second tube from the front is V3, a 6SN7-GTB again with the *hp* logo and *GE* notation on the glass envelopes. Surrounding V3 are V4 and V5, the two 6K6-GT/G output tubes, with the United Electron brand. The V6 5Y3-GT rectifier is an RCA tube, although a 5AR4 is also permitted according to the printing above the tube. The *Table of Replaceable Parts* in the earlier manual lists only the 5Y3. The *AMPLITUDE* pot is located at the front panel beneath the tube shelf. The 600- Ω output transformer is in the bottom-center and the power transformer is at the rear. The two transformer cores are at right angles to each other to limit any flux coupling between them.

Circuit description

The schematic (Figure 4-3 in the HP 200AB manual that came with my HP 200AB) is shown in **Figure 7**. Manuals for this and other vintage HP equipment are readily available for free PDF download on the internet. As I mentioned earlier, the oscillator section tubes in my unit are 6AU6A for V1 and 6AQ5 for V2. The schematic I have shows V1 as 6SJ7 and V2 as another 6K6. Both are octal tubes, while my HP 200AB has miniature tubes for V1 and V2. My unit is S/N 17527 which is above the S/N range in this particular manual. The oscillator is a lamp-stabilized Wien bridge circuit sine oscillator. A four-section variable air capacitor is connected to the frequency dial via a

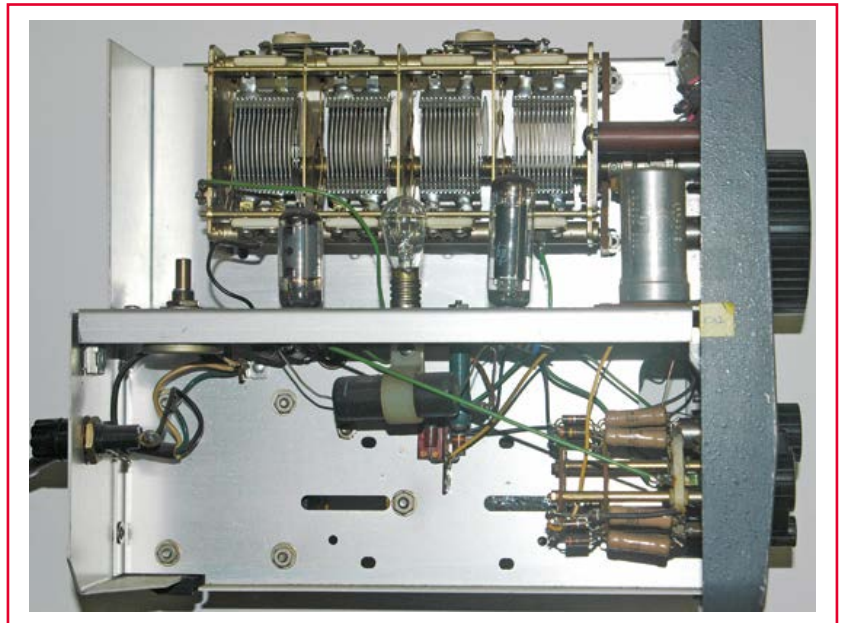

Figure 5.
HP 200AB oscillator section with the light bulb not meant to illuminate anything.

reduction gear, and fixed resistors are used on the RANGE switch. Positive feedback needed to sustain oscillation is taken from V2 output coupling cap C8 back to the R-C Wien bridge section of the oscillator. Negative feedback, needed to minimize distortion and amplitude changes over the entire frequency range, consists of R9, oscillator amplitude trimmer pot R10, and filament lamp R11. The lamp resistance will increase in proportion to the oscillator voltage, which increases the amount of negative feedback, returning the oscillator to its normal operating voltage.

Figure 6.
HP 200AB Amplifier and Power Supply sections.



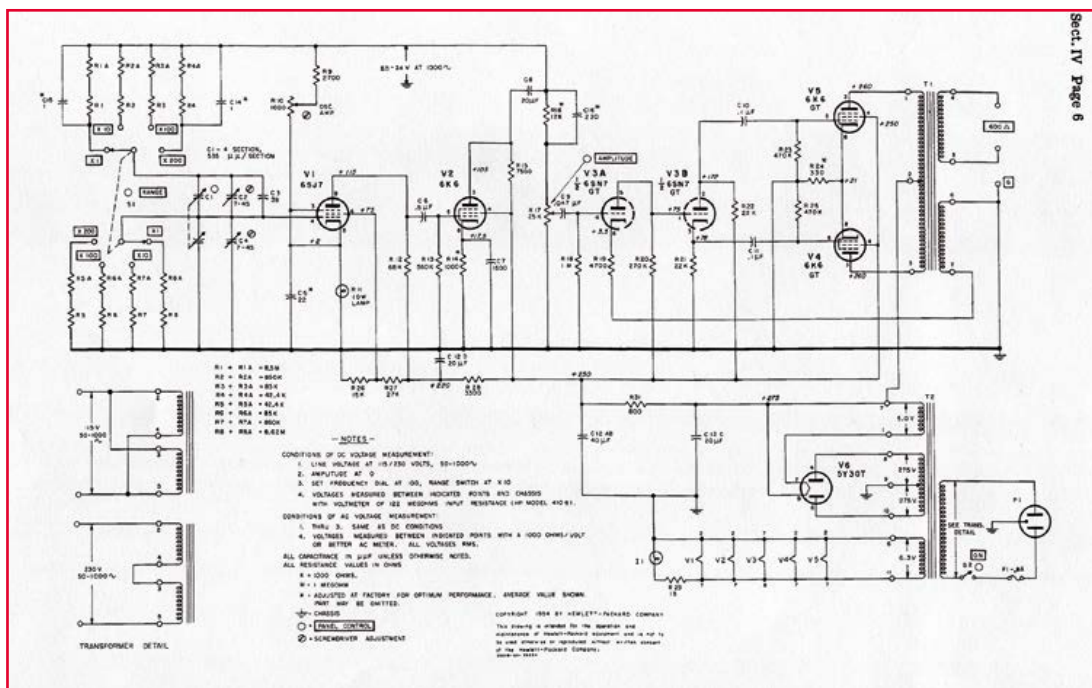

Figure 7.
HP 200AB Audio Oscillator
Schematic.

The stable oscillator range is shown as 20-24 V_{rms} at 1 kHz on the schematic. The oscillator amplitude of my HP 200AB was 28.7 V_{rms} . This is reduced by R16 to 15.3 V_{rms} at the top of R17 AMPLITUDE control to prevent the amplifier output voltage from clipping at any range of frequency and amplitude. There is a slight $\pm 0.05 V_{rms}$ variation in oscillator voltage as the AMPLITUDE control is adjusted from zero to 100. The amplifier section is a conventional push-pull output stage (V4, V5), with V3A as the input amplifier and V3B as the phase splitter. Since the oscillator voltage is so high, the voltage gain

from the AMPLITUDE control to the 600- Ω output winding is just 2 (1.26 dB). A tertiary winding on the output transformer provides about 30 dB of overall negative feedback. V3A provides some local feedback since the cathode resistor R19 is not bypassed.

The power supply is typical of tube amplifiers. Tube V6 provides full wave rectification, followed by R-C pi filters for the tube plate and screen grid supplies.

(130423)

Weblinks, References

- [1] www.hp.com/hpinfo/about/hp/histnfacts/museum/index.html
- [2] RETMA was the Radio Electronics Television Manufacturer's Association (formed in 1953), which was superseded by the Joint Electron Device Engineering Council (JEDEC) in 1958. The early manufacturer letter codes used by HP and others were later replaced by unique five digit CAGE (Commercial and Government Entity) codes that identify a given facility at a specific location. Agilent (formerly Hewlett-Packard test equipment group) currently has twenty CAGE codes registered throughout the world. As the number of registered CAGE facilities grew, the first digit was replaced by a letter.

HP 200x, The Series

HP produced additional solid-state test equipment units with 200-series numbers:

- 202H FM/AM Signal Generator
- 203A Variable Phase Generator
- 207H Universal RF Frequency Converter (Univerter)
- 214A/B Pulse Generator
- 226A Time Mark Generator (for oscilloscope time-base calibration)
- 230B Tuned RF Amplifier
- 236A Telephone Test Oscillator
- 250B RX Meter (RF impedance)
- Several other 200-series waveguide adapters

Original images requested—pls send to editor@elektor.com



We're celebrating a new look — and the next 25 years.



MCU-BASED COLOR DATA ACQUISITION

Our robot's MCU captures and processes camera images of cube facets



+ robot control + search algorithm execution = solution

IN THIS ISSUE

- Weekly Code Challenge | Q&A: Pro Electronics Entrepreneur
- Rubik's Cube-Solving Robot | R-Pi I/O Board | Robotic Neural Networks
- Battery Basics for Engineers | LED Characterization | Cooling Servers
- | Tips for Using BMP Files ■ Electronics Beyond Silicon

25% OFF CIRCUIT CELLAR

Whether it's **programming advice** or **design applications**, you can rely on *Circuit Cellar* for solutions to all your electronics challenges. **Raspberry Pi**, **embedded Linux**, **low-power design**, **memory footprint reduction** and more! Become a member, and see how the hottest new technologies are put to the test.

JOIN TODAY!

www.circuitcellar.com/sepN13

Hexadoku The Original Elektorized Sudoku

Here's a fresh episode of the renowned Elektor Hexadoku conundrum. Even though your hexadecimal may be a bit rusty, straightforward logical thinking should permit 'cracking the code'. Find the solution in the gray boxes, submit it to us by email, and you automatically enter the prize draw for one of five Elektor book vouchers.

The Hexadoku puzzle employs numbers in the hexadecimal range 0 through F. In the diagram composed of 16 × 16 boxes, enter numbers such that **all** hexadecimal numbers 0 through F (that's 0-9 and A-F) occur once only in each row, once in each column and in each of the 4×4 boxes (marked by the thicker black lines).

A number of clues are given in the puzzle and these determine the start situation.

Correct entries received enter a prize draw. All you need to do is send us **the numbers in the gray boxes**.

Solve Hexadoku and win!

Correct solutions received from the entire Elektor readership automatically enter a prize draw for five Elektor Book Vouchers worth **\$70.00 (£40.00 / €50.00)** each, which should encourage all Elektor readers to participate.

Participate!

Before April 1, 2014, supply your name, street address and the solution (the numbers in the gray boxes) by email to: hexadoku@elektor.com

Prize winners

The solution of the December 2013 Hexadoku is: **AC023**.

The Eurocircuits \$140.00 (£80.00) voucher has been awarded to Marij Knops (Netherlands).

The Elektor \$60.00(£40.00) book vouchers have been awarded to Martin Müller (Switzerland); Merle Smith (USA); Gérard Swiatly (France).

Congratulations everyone!

				3		9	2		5						
F					8	4	0	C							9
1	A				C			E						3	6
8	3	9		E					D		A	4	5		
7	B	C	E		A				6		3	4	5	1	
4	8	F	1	7						C	9	D	A	2	
D	6	2	3	B	1				4	A	C	8	0	7	
5	0	A	9	2	C	4			1	8	7	B	F	6	E
9	C	E	B	D	8	F			3	A	5	4	1	2	0
6	D	1	4	C	0				2	B	E	3	F	A	
A	F	7	0	1						4	5	6	9	8	
3	2	5	8		4				0		7	B	C	D	
2	1	D		F						E		5	8	3	
C	7				2				5					1	4
E					1	A	3	8							B
				7	D	1	9								

4	2	D	5	1	F	E	7	B	C	A	8	3	6	0	9
8	3	B	F	C	4	0	6	D	5	7	9	E	A	2	1
9	A	C	0	2	3	D	8	E	F	6	1	B	5	4	7
1	6	7	E	5	9	B	A	0	2	3	4	F	8	C	D
5	4	E	1	9	0	A	C	2	6	8	F	D	7	B	3
A	C	F	2	B	1	6	3	9	7	D	0	4	E	5	8
0	B	3	8	D	2	7	4	C	E	1	5	9	F	6	A
D	7	6	9	E	5	8	F	3	A	4	B	C	0	1	2
3	0	4	A	7	6	C	B	F	D	9	E	1	2	8	5
6	8	5	D	3	A	4	9	1	B	0	2	7	C	F	E
B	E	1	C	F	D	2	0	A	8	5	7	6	9	3	4
F	9	2	7	8	E	1	5	4	3	C	6	A	B	D	0
E	D	8	6	4	7	9	1	5	0	B	C	2	3	A	F
2	1	9	B	A	8	5	E	6	4	F	3	0	D	7	C
7	F	0	4	6	C	3	D	8	9	2	A	5	1	E	B
C	5	A	3	0	B	F	2	7	1	E	D	8	4	9	6

The competition is not open to employees of Elektor International Media, its business partners and/or associated publishing houses.

Being Accurate

By Gerard Fonte (USA)

There's a big difference between resolution and accuracy. It's easy to create something that has very high resolution. That is: something that can determine if two measurements are different. Most hobbyists can build simple circuits that can resolve six decades, or one part-per-million (ppm) without too much trouble. Obviously, it's very much harder to measure something and refer it to a standard. That's called accuracy. Typical accuracies for enthusiasts' projects are 0.1% to 1% (or 1000 to 10,000 ppm). Often they are much worse.

Reference

Fundamentally, for anything to be accurate, it must be referenced to some agreed-upon standard. Obvious standards are ohms, volts, seconds, etc. Therefore, any design must incorporate these standards. Let's examine a simple voltage divider made from two identical resistors (in series) and connected to 10 volts (in theory the actual resistance doesn't matter). The voltage from the resistor junction to ground should be 5 volts. Assuming that the resistors are perfectly identical (which is a "resolution" measurement that we can make to 1 ppm), any difference from 5 volts (greater than 1 ppm) is due to either the 10 volts not being 10 volts or that our voltmeter is not reading 5 volts properly. Which is it? Without some standard reference, we can never be sure. What we see is that any product must contain some "absolute" standard in order to be accurate. An absolute reference is usually a device that is guaranteed to provide some standard reference. Typically these are voltage or current references. Sometimes the standards are not what you would think.

The most common reference is a voltage. Often this is the operating voltage of the product. Most microprocessors (uP) use the supply voltage as the reference for the internal Analog to Digital converter (A/D). If it's running from a regulated 5-volt supply it's important to remember that most three-terminal regulators have 5% tolerance. And if it's running from batteries, it could be in error by 20% or more. So, if the uP has a ten-bit A/D, it can resolve 0.1% with a guaranteed accuracy 5% or worse. This may not be what you expected.

Clearly, to increase the accuracy we need to add a better reference. Zener diodes aren't much of an improvement. A precision, five volt, $\pm 0.1\%$ reference is available for a couple of dollars. (That's only ± 5 mV of error.) But going beyond $\pm 0.1\%$ gets expensive quickly and a brief search didn't turn up anything more accurate than $\pm 0.02\%$.

Calibration

So how is it possible to build voltmeters with five, six or more digits of accuracy when the best voltage reference is only three digits? There are two ways. The first is to calibrate each voltmeter to a standard. The

second is to develop a different reference.

Calibration is the typical method of ensuring accuracy. The manufacturer obtains a voltage standard that is traceable to NIST. This is often called a transfer standard or secondary standard. Once you have this, you can compare what your voltmeter says to what the standard is and adjust your voltmeter to match. Simple and straightforward. However, this requires periodic tests to verify that the voltmeter hasn't changed over time. The typical "calibration" standard is one year. That is, every instrument should be verified against a standard every year. This is part of every industrial quality control process.

While it is not practical for e-enthusiasts to recalibrate their test gear every year, you should have a collection of "standard" high-quality resistors, capacitors, etc. that are kept only for this function. You should test your equipment regularly and keep a log of the results. It's fast, cheap and easy, and will let you know immediately if something changes. There's nothing worse than being unable to trust your instruments.



Roll Your Own

It is often the case that you can translate one measurement onto another that allows better accuracy. For example, it is extremely easy to achieve very high accuracy when measuring frequency or time. You can buy a 32,768 Hz watch crystal for about \$0.75 that has 10-ppm accuracy (that's $\pm 0.001\%$). You can't get more bang for your buck than that.

Therefore, instead of measuring a voltage with a voltage reference of only 0.1%, convert your voltage to a frequency and measure to 0.001%. That's an improvement by a factor of 100. There are many ways to change volts to hertz. You can buy chips that do that for you or you can design your own converter. And you will still need to calibrate to a standard. But this standard can simply be a good voltmeter (new 5.5-digit voltmeters can cost about \$400). That's a lot of money (used ones are a lot cheaper) but if you are serious about accuracy, you will need something like this. This conversion approach is used all the time in engineering. In fact, you should always consider conversion to time/frequency for high accuracy measurements.

Can't Get There From Here

It's impossible to create any accurate device without some eventual reference to a standard. Some standards are based on repeatable physical characteristics, like the oscillations of cesium atoms in an atomic clock. Others are more down to earth. The standard kilogram is a 39.17-mm platinum-iridium cylinder stored in France. If you can develop a better standard for mass, the world will beat a path to your door. And the more you look at standards, the more you realize how indispensable they are.

(130473)

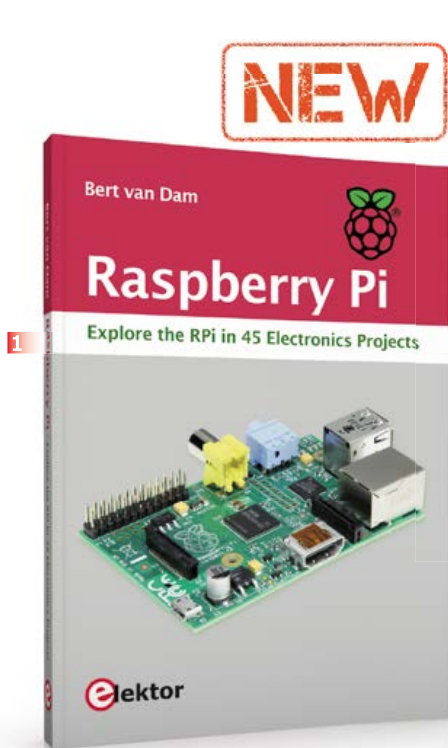

15% DISCOUNT
for GREEN and GOLD Members!
www.elektor.com/march

Explore the RPi in 45 Electronics Projects

1 Raspberry Pi

This book addresses one of the strongest aspects of the Raspberry Pi: the ability to combine hands-on electronics and programming. No fewer than 45 exciting and compelling projects are discussed and elaborated in detail. From a flashing lights to driving an electromotor; from processing and generating analog signals to a lux meter and a temperature control. We also move to more complex projects like a motor speed controller, a webserver with CGI, client-server applications and Xwindows programs. Each project has details of the way it got designed that way. The process of reading, building and programming not only provides insight into the Raspberry Pi, Python, and the electronic parts used, but also enables you to modify or extend the projects any way you like.

288 pages • ISBN 978-1-907920-27-1
£34.95 • € 39.95 • US \$56.40

Learning to fly with Eagle

2 EAGLE V6 Getting Started Guide

This book will quickly allow you to obtain an overview of the main modules of EAGLE: the schematic editor; layout editor and autorouter in one single interface. You will apply your knowledge of EAGLE commands to

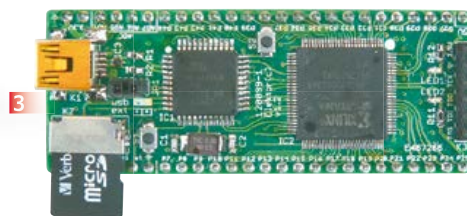

a small project, learn more about some of the advanced concepts of EAGLE and its capabilities and understand how EAGLE relates to the stages of PCB manufacture. After reading this book while practicing some of the examples and completing the projects, you should feel confident about taking on more challenging endeavors.

208 pages • ISBN 978-1-907920-20-2
£29.50 • € 34.50 • US \$47.60

Taming the Beast

3 FPGA Development Board

FPGAs are unquestionably among the most versatile but complex components in modern-day electronics. An FPGA contains a maze of gates and other circuit elements that can be used to put together your own digital circuit on a chip. This FPGA development board (designed in the Elektor Labs) shows how easy it is for any electronics enthusiast, whether professional or amateur, to work with these programmable logic devices.

Module, ready build and tested
Art.# 120099-91 See www.elektor.com/fpgaboard

The luxury of precision within everyone's reach

4 500 ppm LCR Meter

The remarkable precision of this device and its amazing ease of use are the result of careful design. It works so

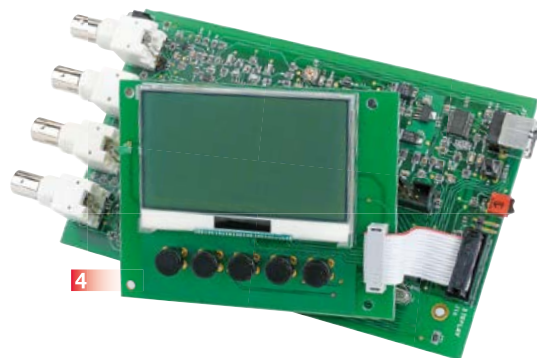

well behind its uncluttered front panel that one could almost forget the subtleties of the measurement techniques employed. A dream opportunity for our readers who are passionate about measurement to enjoy themselves. If, like us, you wonder at the marvels modern techniques bring within our reach, come along and feel the tiny fraction of a volt.

Set: main board and LCD board, assembled and tested

Art.# 110758-93
See www.elektor.com/lcrometer

140 Minutes video presentation and more

5 DVD Feedback in Audio Amplifiers

In this Masterclass we address several aspects of feedback in audio amplifiers. The focus of this Masterclass, although not entirely math-free, is on providing insight and understanding of the issues involved. Presenter Jan Didden provides a clear overview of the benefits that can be obtained by feedback and its sibling, error correction; but also of its limitations and disadvantages. Recommended to audio designers and serious audio hobbyists!

ISBN 978-907920-16-5
£24.90 • € 29.95 • US \$40.20



6

NEW



7

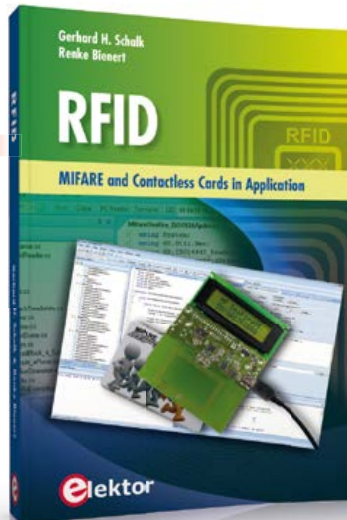

8

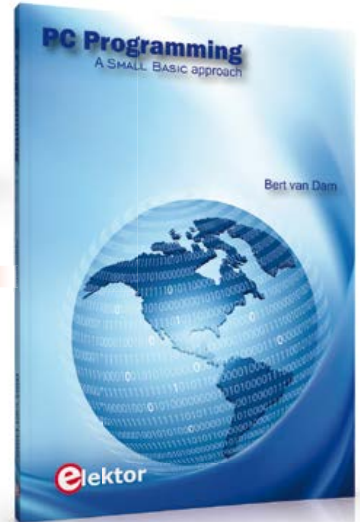

9

All articles in Elektor Volume 2013

6 DVD Elektor 2013

This DVD-ROM contains all editorial articles published in Volume 2013 of the English, American, Spanish, Dutch, French and German editions of Elektor. Using the supplied Adobe Reader program, articles are presented in the same layout as originally found in the magazine. An extensive search machine is available to locate keywords in any article. With this DVD you can also produce hard copy of PCB layouts at printer resolution, adapt PCB layouts using your favorite graphics program, zoom in / out on selected PCB areas and export circuit diagrams and illustrations to other programs.

ISBN 978-90-5381-277-8

£23.50 • € 27.50 • US \$37.90

Programming step-by-step

7 Android Apps

This book is an introduction to programming apps for Android devices. The operation of the Android system is explained in a step by step way, aiming to show how personal applications can be programmed. A wide variety of applications is presented based on a solid number of hands-on examples, covering anything from simple math programs, read-

ing sensors and GPS data, right up to programming for advanced Internet applications. Besides writing applications in the Java programming language, this book also explains how apps can be programmed using Javascript or PHP scripts. When it comes to personalizing your smartphone you should not feel limited to off the shelf applications because creating your own apps and programming Android devices is easier than you think!

244 pages • ISBN 978-1-907920-15-8

£34.95 • € 39.95 • US \$56.40

MIFARE and Contactless Cards in Application

8 RFID

MIFARE is the most widely used RFID technology, and this book provides a practical and comprehensive introduction to it. Among other things, the initial chapters cover physical fundamentals, relevant standards, RFID antenna design, security considerations and cryptography. The complete design of a reader's hardware and software is described in detail. The reader's firmware and the associated PC software support programming using any .NET language. The specially developed PC program, "Smart Card Magic.NET", is a simple development environment that supports sending commands to a card at the click of a mouse, as well as the ability

to create C# scripts. Alternatively, one may follow all of the examples using Visual Studio 2010 Express Edition. Finally, the major smart card reader API standards are introduced. The focus is on programming contactless smartcards using standard PC/SC readers using C/ C++, Java and C#.

484 pages • ISBN 978-1-907920-14-1

£44.90 • € 49.90 • US \$72.50

A Small Basic approach

9 PC Programming

There are many different PC programming languages available on the market. They all assume that you have, or want to have, a knack for technology and difficult to read commands. In this book we take a practical approach to programming. We assume that you simply want to write a PC program, and write it quickly. Not in a professional environment, not in order to start a new career, but for plain and simple fun... or just to get a task done. Therefore we use Small Basic. You will have an application up and running in a matter of minutes. You will understand exactly how it works and be able to write text programs, graphical user interfaces, and advanced drivers.

194 pages • ISBN 978-1-1-907920-26-4

£29.50 • € 34.50 • US \$47.60

10



11



12

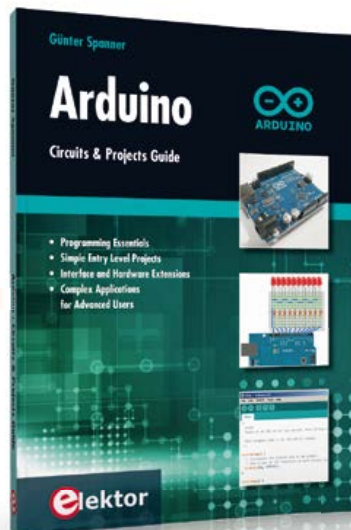

13

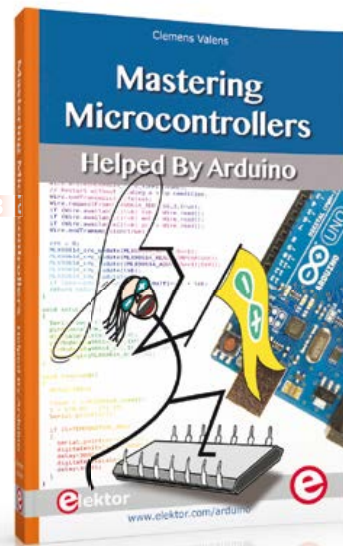

Lots of power with low distortion

10 Q-Watt Audio Power Amplifier

Elektor has a long history with audio power amplifiers. We are proud to present yet another fully analog circuit developed entirely in house. Despite the simple design of this audio power amp with just one pair of transistors in the output stage, Q-Watt can deliver over 200 quality (Q!) watts into 4 ohms with exceptionally low distortion thanks to the use of a special audio driver IC. Due to popular demand, this project is now supported by a semi-kit containing everything you need to build a stereo amplifier.

2 PCBs and all electronic parts
Art.#110656-72
£151.25 • € 169.95 • US \$244.00

110 Issues, more than 2,100 articles

11 DVD Elektor 1990 through 1999

This DVD-ROM contains the full range of 1990-1999 volumes (all 110 issues) of Elektor Electronics magazine (PDF). The more than 2,100 separate articles have been classified chronologically by their dates of publication (month/year), but are also listed alpha-

betically by topic. A comprehensive index enables you to search the entire DVD. What's more, this DVD also contains the entire 'The Elektor Datasheet Collection 1...5' CD-ROM series, with the original full datasheets of semiconductors, memory ICs, microcontrollers, and much more.

ISBN 978-0-905705-76-7
£69.00 • € 89.00 • US \$111.30

Circuits & Projects Guide

12 Arduino

The Arduino user is supported by an array of software libraries. In many cases, detailed descriptions are missing, and poorly described projects tend to confuse rather than elucidate. This book represents a different approach. All projects are presented in a systematical manner, guiding into various theme areas.

In the coverage of must-know theory great attention is given to practical directions users can absorb, including essential programming techniques like A/D conversion, timers and interrupts—all contained in the hands-on projects. In this way readers of the book create running lights, a wakeup light, fully functional voltmeters, precision digital thermometers,

clocks of many varieties, reaction speed meters, or mouse controlled robotic arms. While actively working on these projects the reader gets to truly comprehend and master the basics of the underlying controller technology.

260 pages • ISBN 978-1-907920-25-7
£34.95 • € 39.95 • US \$56.40

Helped By Arduino

13 Mastering Microcontrollers

The aim of this book is not only to let you enter the World of Arduino, but also to help you emerge victorious and continue your microcontroller programming learning experience by yourself. In this book theory is put into practice on an Arduino board using the Arduino programming environment.

Having completed this fun and playful course, you will be able to program any microcontroller, tackling and mastering I/O, memory, interrupts, communication (serial, I²C, SPI, 1-wire, SMBus), A/D converter, and more. This book will be your first book about microcontrollers with a happy ending!

348 pages • ISBN 978-1-907920-23-3
£34.95 • € 39.95 • US \$56.40

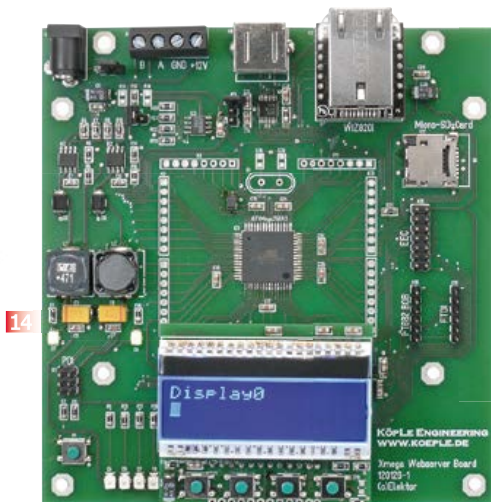

Display, SD card, Ethernet, RS-485, buttons and LEDs

14 XMEGA Web Server Board

This microcontroller board is particularly well suited to monitoring and control applications. The plug-in TCP/IP module allows you to implement a web server and other network-oriented applications and a microSD card provides mass storage. Four LEDs, four buttons, and a removable display provide the user interface options. And of course the board comes with a wide range of external interfaces.

Controller Module

Art.# 120126-91

See www.elektor.com/xmega

An essential source of reference material

15 Process Measurements with C# Applications

Measurement is vital to the successful control of any process. This book introduces PC based measurement systems and software tools for those needing to understand the underlying principles or apply such techniques. Throughout the book, the C# programming language is used to give the reader immediate practical desktop involvement. C-Sharp has a wide support base and is a

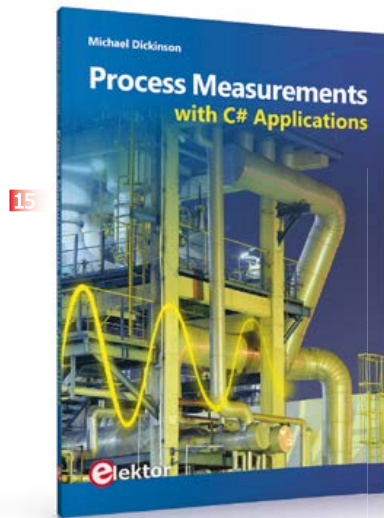

popular choice for engineering solutions. The basics of measurement and data capture systems are presented, followed by examples of software post-processing. Application examples are provided from a range of process industries, with reference to remote monitoring, distributed systems and current industrial practices.

144 pages • ISBN 978-1-907920-24-0

£24.50 • € 27.50 • US \$39.50

Ideal reading for students and engineers

16 Practical Digital Signal Processing using Microcontrollers

This book on Digital Signal Processing (DSP) reflects the growing importance of discrete time signals and their

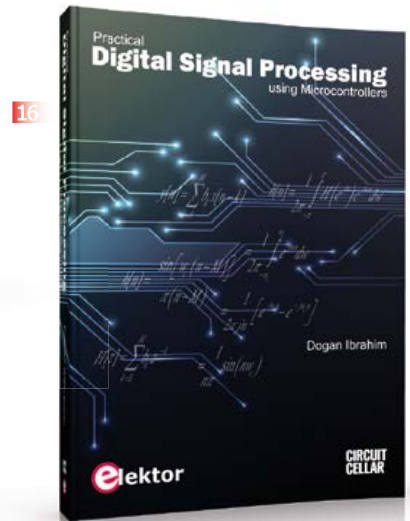

use in everyday microcontroller based systems. The author presents the basic theory of DSP with minimum mathematical treatment and teaches the reader how to design and implement DSP algorithms using popular PIC microcontrollers. The author's approach is practical and the book is backed with many worked examples and tested and working microcontroller programs. The book should be ideal reading for students at all levels and for the practicing engineers who may want to design and develop intelligent DSP based systems. Undergraduate students should find the theory and the practical projects invaluable during their final year projects. Similarly, postgraduate students should be able to develop advanced DSP based projects with the aid of the book.

428 pages • ISBN 978-1-907920-21-9

£44.90 • € 49.90 • US \$72.50

Further Information and Ordering: www.elektor.com/store or contact customer service for your region

UK / ROW

Elektor International Media
78 York Street
London - W1H 1DP United Kingdom
Phone: +44 20 7692 8344
E-mail: service@elektor.com

USA / CANADA

Elektor US
111 Founders Plaza, Suite 300
East Hartford, CT 06108 USA
Phone: 860.289.0800
E-mail: service@elektor.com

NEXT MONTH IN ELEKTOR MAGAZINE



Platino-based Bench Supply

A compact laboratory supply ranks high among the most requested and replicated electronics projects. Typically, such a power supply consists of an analog control circuit and one or two displays showing voltage and current, optionally driven by a microcontroller. By contrast, in this project based on Elektor's universal Platino board the microcontroller is actively used to regulate output voltage and current. The power supply provides two fixed output voltages and an adjustable voltage up to 15 V at 1 A.

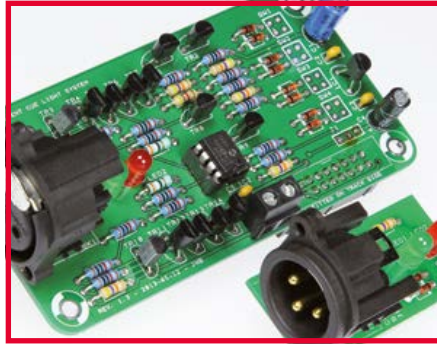

Intelligent Cuelight System

A cuelight system is used in theatres to provide inaudible signals to actors or technicians through colored lights. Most commercial systems use multiple channels, each having their own controls. In this case, we've opted for four groups with Standby and Go buttons, and a central Clear button. The number of channels is virtually unlimited, with each channel board ready for connection to two one or more buses through switches.

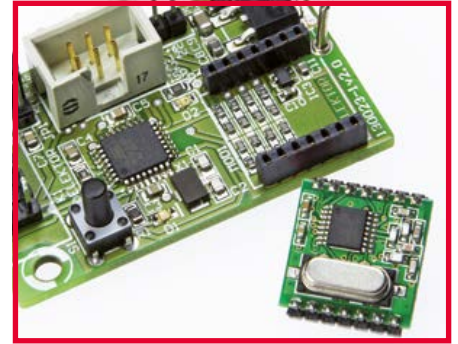

433-MHz Gateway

Small 433-MHz LPR modules are available for wireless measuring, controlling and switching of all kinds of things. These modules are controlled through an SPI interface. A small board was developed to ease their use in other applications, too. Apart from an ISP'ed 433-MHz module the board also contains an ATmega328 and a UART interface. Thanks to pre-programmed firmware an easy-to-use gateway is created capable of sending and receiving UART-supplied characters.

Note: we regret 'Precision Adjustable DC Current Source' could not be accommodated on the current issue as planned

Article titles and magazine contents subject to change, please check www.elektor-magazine.com for updates.

Elektor April 2014 is processed for mailing to US, UK and ROW Members starting March 18, 2014.

See what's brewing
@ Elektor Labs 24/7

Check out
www.elektor-labs.com
and join, share, participate!

The screenshot shows the Elektor Labs website interface. At the top, the logo 'elektor labs' is displayed with the tagline 'Sharing Electronics Projects'. Below the logo is a navigation menu with 'Home', 'News', 'Proposals', 'In Progress', and 'Finished'. A search bar and a 'Log in' button are also visible. The main content area features a large banner for 'Post a February Project' with the text 'The twenty best projects win this LPC1343 ARM Cortex-M3 board'. Below the banner are three columns of project listings: 'Proposals', 'In Progress', and 'Finished'. Each listing includes a thumbnail image, a title, a view count, and a star rating. A 'Create a Project' button is prominently displayed. On the right side, there is a video player showing a video titled 'About Elektor.LABS' and a 'Not a member?' section with a call to action to join for free access.

ORDERING INFORMATION

To order, contact customer service for your region:

USA / CANADA

Elektor US
111 Founders Plaza, Suite 300
East Hartford, CT 06108
USA
Phone: 860.289.0800
E-mail: service@elektor.com

Customer service hours:
Monday-Friday 8:30 AM-4:30 PM EST.

UK / ROW

Elektor International Media
78 York Street
London W1H 1DP
United Kingdom
Phone: (+44) (0)20 7692 8344
E-mail: service@elektor.com

Customer service hours:
Monday-Thursday 9:00 AM-5:00 PM CET.

PLEASE NOTE: While we strive to provide the best possible information in this issue, pricing and availability are subject to change without notice. To find out about current pricing and stock, please call or email customer service for your region.

COMPONENTS

Components for projects appearing in Elektor are usually available from certain advertisers in the magazine. If difficulties in obtaining components are suspected, a source will normally be identified in the article. Please note, however, that the source(s) given is (are) not exclusive.

TERMS OF BUSINESS

Shipping Note:

All orders will be shipped from Europe. Please allow 2-4 weeks for delivery.

Returns

Damaged or miss-shipped goods may be returned for replacement or refund. All returns must have an RA #. Call or email customer service to receive an RA# before returning the merchandise and be sure to put the RA# on the outside of the package. Please save shipping materials for possible carrier inspection. Requests for RA# must be received 30 days from invoice.

Patents

Patent protection may exist with respect to circuits, devices, components, and items described in our books, magazines, online publications and presentations. Elektor accepts no responsibility or liability for failing to identify such patent or other protection.

Copyright

All drawings, photographs, articles, printed circuit boards, programmed integrated circuits, discs, and software carriers published in our books and magazines (other than in third-party advertisements) are copyrighted and may not be reproduced (or stored in any sort of retrieval system) without written permission from Elektor. Notwithstanding, printed circuit boards may be produced for private and educational use without prior permission.

Limitation of liability

Elektor shall not be liable in contract, tort, or otherwise, for any loss or damage suffered by the purchaser whatsoever or howsoever arising out of, or in connection with, the supply of goods or services by Elektor other than to supply goods as described or, at the option of Elektor, to refund the purchaser any money paid with respect to the goods.

MEMBERSHIPS

Membership renewals and change of address should be sent to the Elektor Membership Department for your region:

USA / CANADA

Elektor USA
P.O. Box 462228
Escondido, CA 92046
Phone: 800-269-6301
E-mail: elektor@pcspublink.com

UK / ROW

Elektor International Media
78 York Street
London W1H 1DP
United Kingdom
Phone: (+44) (0)20 7692 8344
E-mail: service@elektor.com



Do you want to become an Elektor GREEN or GOLD Member or does your current Membership expire soon?

Go to www.elektor.com/member.

CadSoft
presents

PCBSim

EAGLE

V6

the new simulation tool for signal integrity tests*:

- Signal integrity testing before the layout to avoid redesign
- Integration in EAGLE and intuitive operation
- Accurate simulation results
- Support directly from manufacturer

*developed by Felicitas Customized Engineering

Visit us in Hall 5-249 and get to know more:



www.cadsoftusa.com

25 years CadSoft



1988 - 2013