

Thermometer using Giant Gottlieb® Displays

eLektor

www.elektor.com

Preamplifier 2012

A truly high-end audio control preamp



Part 1
line-in • tone •
volume •
output board

RS-485 Switch Board – ElektorBus Relay Module

Automation application switches two AC powered loads

LED Touch Panel

Make your own touch-sensitive matrix

RFID Reader Hacks

Deep into Mifare/Oyster and iClass devices

US \$ 7.95 - Canada \$ 7.95



0 74470 24965 8 04

Embedded Internet is Just One Plug Away



WIZ820io Internet Offload Module

- Plug-in module with TCP/IP, 10/100 Ethernet MAC/PHY, transformer & RJ-45
- Breadboard Friendly
- 8 high-speed hardware sockets
- High-speed SPI Interface
- Power Down Mode & Wake-on LAN
- 23mm x 25mm PCB size
- Arduino Compatible

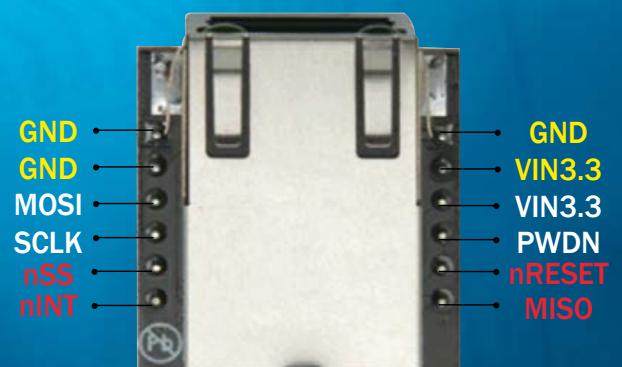

Get more information at www.WiznetTechnology.com

3003 N First Street, San Jose, CA 95134, USA TEL : 408-232-5415

E-mail : sales@wiznettechnology.com

**We are PIC®
freaks.
Just like you.**



Choose the compiler in programming language you love the most - **mikroC™**, **mikroBasic™** or **mikroPascal™**. With over 500 library functions, lots of examples, a great help file, you will get the job done quickly.

Easily create GLCD or TFT user interfaces using **Visual TFT™** and **Visual GLCD™** software. Just focus on design and code will be created for you automatically.



mikroProg™ is a fast USB 2.0 programmer with mikroLCD™ hardware In-Circuit Debugger. It supports over 570 PIC®, dsPIC® and PIC32® devices.



COMPLETE PIC® DEVELOPMENT SOLUTION



Over 200 IDC10 and mikroBUS™ compatible Click™ additional boards are here to meet your development ideas.



EasyPIC PRO™ v7 is the best place for 3.3V and 5V high-pin count PIC18® devices. It features on-board ICD, three mikroBUS™ sockets, and lots of modules.

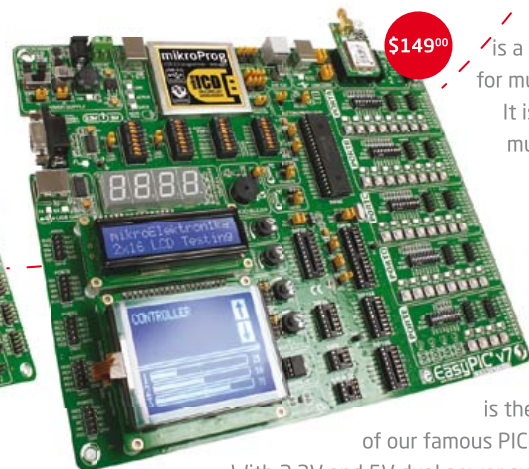

EasyPIC™ v7 is the seventh generation of our famous PIC development board. With 3.3V and 5V dual power supply it supports over 250 PIC microcontrollers, and features on-board ICD, two mikroBUS™ sockets, and lots of modules.

mikromedia™ for PIC® 18FJ is a real swiss army knife for multimedia developers. It is packed with lots of multimedia peripherals.

In the beginning was the noise

One of the naturally evolved missions of Elektor magazine is to present a mix of analog and digital electronics, with and without microcontrollers, for beginners and professionals alike. Every month, every electronics fan on our readership should be captured, triggered, surprised, impressed or irritated by at least one article he or she can explore for educational or professional use.

In this month's edition the article that attracts me most is the new high-end audio preamp called Preamplifier 2012. Old time Elektor readers may remember an earlier design, also with a short name that makes a statement: "The Preamp" from 1986. Twenty six years on, we present another audio control preamplifier where signal quality is paramount. This time, special attention is given to noise reduction techniques like Low Impedance Design, but still no frills, bells and whistles, and everything aimed to achieve the purest possible processing of stereo audio signals between the source (MD/MM record player or CD player) and the power amp. Unlike the 1986 "Preamp", the 2012 version was designed by an external contributor, Douglas Self, in cooperation with Elektor (audio) Labs staffers for the practical implementation like PCB design and professional testing. Douglas' and our goals are essentially the same, so I feel confident in adding the latest design to the series of legendary high-end audio designs published by Elektor these past 40 years or so.

For some of the highly interesting technical details of the Preamplifier 2012, dash off to page 16 where "all is revealed & more to follow". The beauty of the project is in the total absence of any luxury: you'll search in vain for a remote control, a USB connector, a display or a Chinese switch-mode PSU. Instead, you'll only find what it takes to enjoy music in its purest form. Isn't that's what it's all about? True audiophiles will concur I'm sure, others might shake their heads wearily. They probably don't know what they are missing!

Now, to return quickly to today's harsh reality of virtual dominance by microcontrollers and software: rest assured that there's plenty of it in this edition. So if you're not captured by high-end audio, then skip that one article on antediluvian analog audio electronics. No offence!

Enjoy reading this edition,
Jan Buiting, Managing Editor

elektor

6 Colophon

Who's who at Elektor.

8 News & New Products

A monthly roundup of all the latest in electronics land.

15 What are you Doing?

This month we interviewed Eben Upton to find out what the \$25 Raspberry Pi computer is all about.

16 Preamplifier 2012 (1)

Introducing our new extremely high end audio preamp and kicking off with the Line-In, Tone, Volume and Output sections.

24 RS-485 Switch Board

This relay module for the ElektorBus enables AC powered loads to be switched remotely, say, from a smartphone.

30 LED Touch Panel

Utilizing IR light bouncing off a fingertip to make a surprisingly reliable touch sensor for easy use in embedded applications.

36 AVR Software Defined Radio (2)

The series continues this month with digital sampling in theory and practice, complete with a Universal Receiver board you can build.

44 E-Labs Inside: Hackerspace #42

A visit, camera in hand, to one of Holland's most active hackerspace groups.

48 Thermometer using Giant Gottlieb® Displays

Ever seen a pair of 4-inch diameter pinball score wheels indicating the water temperature in a French swimming pool?

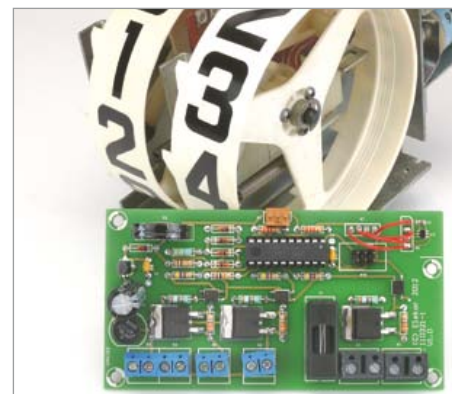
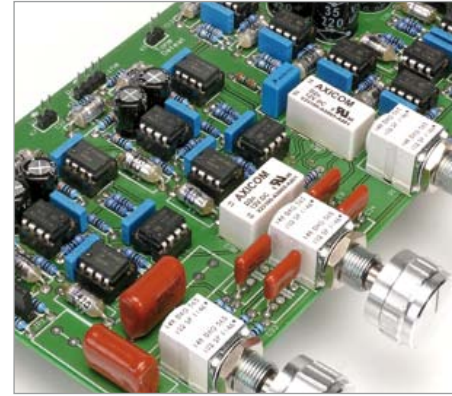

CONTENTS

Volume 4
April 2012
no. 40



16 Preamplifier 2012 (1)

Besides presenting a truly high end audio control preamplifier for home construction, this article series also aims to show how low-impedance design and multiple-amplifier techniques can be used to significantly reduce the noise levels in analog circuitry. The result of the design effort is a top-notch preamp that's brilliant not just sonically but also in terms of cost/performance ratio.



36 AVR Software Defined Radio (2)

Here we will use an ATmega88 to sample amplitude- and phase-modulated signals, which we can either synthesise ourselves or fish out of the ether. We can even operate at frequencies of above 100 kHz. This article also describes the Universal Receiver Board used for a number of experiments.



48 Thermometer using Giant Gottlieb® Displays

Here's a stunning application of reels of a 1960s pinball scoring unit – a swimming pool thermometer! Once the temperature is displayed, the consumption of the circuit drops to zero, but the temperature display remains perfectly visible. There are no batteries (dry or rechargeable), adjustments, or maintenance.



54 RFID Reader Hacks

This article tells you how to modify an existing RFID reader so it can read MIFARE ISO 14443 cards. Alternatively, reverse engineering may be applied to build the entire reader yourself and you are ready to explore the technology behind MIFARE type cards including Oyster and others using similar protocols.

54 RFID Reader Hacks

Among other types of RFID card, the MIFARE ISO 14443 is worth exploring using a hacked or reverse-engineered reader device.

60 Electronics for Starters (4)

This month we explore and learn how bipolar transistors and junction FETs can be used as constant-current sources.

64 The RL78 Microcontroller

A look at the hardware and software that comprises Renesas' RL78 platform of 16-bit MCUs. We also review the awesome starter kit for the RL7/G13.

68 Component Tips

Raymond's Pick of the Month: isolation devices ADM2587E and ADuM3160

70 Gerard's Columns: Reliability

The monthly contribution from our US columnist Gerard Fonte.

71 Retronics: Philips EL3581 Dictaphone (ca. 1960)

Series Editor: Jan Buiting

76 Hexadoku

Elektor's monthly puzzle with an electronics touch.

84 Coming Attractions

Next month in Elektor magazine.

The Team

| | |
|--------------------------------|---|
| Managing Editor: | Jan Buiting (editor@elektor.com) |
| Deputy Editor: | Thijs Beckers |
| International Editorial Staff: | Harry Baggen, Eduardo Corral, Wisse Hettinga, Denis Meyer, Jens Nickel, Clemens Valens |
| Design Staff: | Thijs Beckers, Ton Giesberts, Luc Lemmens, Raymond Vermeulen, Jan Visser |
| Membership Manager: | Shannon Barraclough |
| Graphic Design & Prepress: | Giel Dols, Jeanine Opreij, Mart Schroijen |
| Online Manager: | Carlo van Nistelrooy |
| Managing Director: | Don Akkermans |

The Network



Our international teams

 **United Kingdom**
Wisse Hettinga
+31 (0)46 4389428
w.hettinga@elektor.com

 **Spain**
Eduardo Corral
+34 91101 93 95
e.corral@elektor.es

 **India**
Sunil D. Malekar
+91 9833168815
ts@elektor.in

 **USA**
Hugo Vanhaecke
+1 860-875-2199
h.vanhaecke@elektor.com

 **Italy**
Maurizio del Corso
+39 2.66504755
m.delcorso@inware.it

 **Russia**
Nataliya Melnikova
8 10 7 (965) 395 33 36
nataliya-m-larionova@yandex.ru

 **Germany**
Ferdinand te Walvaart
+31 46 4389417
f.tewalvaart@elektor.de

 **Sweden**
Wisse Hettinga
+31 46 4389428
w.hettinga@elektor.com

 **Turkey**
Zeynep Köksal
+90 532 277 48 26
zkoksal@beti.com.tr

 **France**
Denis Meyer
+31 46 4389435
d.meyer@elektor.fr

 **Brazil**
João Martins
+55 11 4195 0363
joao.martins@editorialbolina.com

 **South Africa**
Johan Dijk
+27 78 2330 694 / +31 6 109 31 926
j.dijk@elektor.com

 **Netherlands**
Harry Baggen
+31 46 4389429
h.baggen@elektor.nl

 **Portugal**
João Martins
+351 21413-1600
joao.martins@editorialbolina.com

 **China**
Cees Baay
+86 21 6445 2811
CeesBaay@gmail.com

No. 40, APRIL 2012

ISSN 1947-3753

Elektor (ISSN 1947-3753) is published monthly (except for one issue in July/August) at \$39.95 per year, Canada add \$11.00 per year; by Elektor International Media LLC, 4 Park Street, Vernon, CT 06066, USA. Phone: 860-875-2199, Fax: 860-871-0411. www.elektor.com

Elektor is also published in French, Spanish, German and Dutch. Together with franchised editions the magazine is on circulation in more than 50 countries.

Subscriptions:
Elektor USA, P.O. Box 462228, Escondido, CA 92046.
Phone: 800-269-6301
E-mail: elektor@pcspublink.com
Internet: www.elektor.com

Head Office:

Elektor International Media b.v.
PO Box 11 NL-6114-ZG Susteren The Netherlands
Telephone: (+31) 46 4389444. Fax: (+31) 46 4370161

US Advertising:

Strategic Media Marketing, Peter Wostrel,
1187 Washington St., Gloucester MA 01930 USA.

Membership Counter

We
now have

276130

members
in

83

countries.

**Subscribe now to the world's most comprehensive
magazine on electronics and microcontrollers!**

Sign up at www.elektor.com/members

Supporting Companies

| | | | |
|---|---|---|--|
|  | AP Circuits www.apcircuits.com 27 |  | MikroElektronika www.mikroe.com 3 |
|  | Beta Layout www.pcb-pool.com 69 |  | Oscium www.oscium.com 88 |
|  | Bitscope www.bitscope.com/us 13 |  | Parallax www.parallax.com 33 |
|  | DesignSpark chipKIT™ Challenge www.chipkitchallenge.com 14 |  | Pololu www.pololu.com 73 |
|  | DLP Design www.dlpdesign.com 69 |  | Renesas Contest www.circuitcellar.com/RenesasRL78Challenge 29 |
|  | Elprotronic www.elprotronic.com 27 |  | Saelig www.saelig.com 11 |
|  | Elsevier www.newnespress.com 35 |  | Sensors Expo 2012 www.sensorsexpo.com 75 |
|  | ExpressPCB www.expresspcb.com 9 |  | Wiznet www.wiznettechnology.com 2 |
|  | FTDI www.ftdichip.com 23 | | |

Not a supporting company yet?

Contact Peter Wostrel (peter@smmarketing.us, Phone 978-281-7708, Fax 978-281-7706)
to reserve your own space for the next edition of our members' magazine

Phone: 978-281-7708, Fax: 978-281-7706
E-mail: peter@smmarketing.us
Advertising rates and terms available on request.

Copyright Notice

The circuits described in this magazine are for domestic use only. All drawings, photographs, printed circuit board layouts, programmed integrated circuits, disks, CD-ROMs, DVDs, software carriers and article texts published in our

books and magazines (other than third-party advertisements) are copyright Elektor International Media b.v. and may not be reproduced or transmitted in any form or by any means, including photocopying, scanning or recording, in whole or in part without prior written permission from the Publisher. Such written permission must also be obtained before any part of this publication is stored in a retrieval system of any nature. Patent protection may exist in respect of circuits, devices, components etc. described in this magazine. The Publisher does not accept

responsibility for failing to identify such patent(s) or other protection. The submission of designs or articles implies permission to the Publisher to alter the text and design, and to use the contents in other Elektor International Media publications and activities. The Publisher cannot guarantee to return any material submitted.

© Elektor International Media b.v. 2012 Printed in the USA

DIP switch is process-sealed for surface-mount soldering, washable-processing

C&K Components' new ultra-miniature, surface-mount DIP switch delivers consistent electrical performance and high reliability. The half-pitch TDA Series DIP switch features bifurcated contacts that provide increased electrical reliability when compared to other contact technologies. In addition, the switches are process-sealed for both surface-mount soldering and washable-processing, making them ideal for hand-held electronics devices, port-

able computer devices, and instrumentations and controls.

"C&K has made the investment to enhance and expand our DIP switch product offering, delivering new switch features and options that provide design engineers with flexibility when specifying a DIP switch for a particular design," said Owen Camden, Business Development Manager at C&K Components.

The RoHS-compliant TDA Series is available in two termination styles, S-termination (Gullwing) and J-termination (Bend). The single pole, single throw (SPST) DIP switch is available in multiple positions, including 2, 4, 6, 8 and 10 positions. The TDA Series DIP switch features a contact rating of 24 VDC, 25 mA (switching state) and 50 V DC, 100 mA



(steady state). The TDA Series DIP switch provides a maximum contact resistance of 100mΩ. Operating temperature ranges from -40°C to +85°C. The TDA Series switches are available in tape and reel or tube packaging.

www.ck-components.com
(120209-10)

Towards fully electrical vehicles, "so driving feels the same"



On behalf of the ESTRELIA (Energy Storage with lowered cost and improved Safety and Reliability for electrical vehicles) consortium, project leader austriamicrosystems announces successful progress of the first six months of the EU FP7 project ESTRELIA. ESTRELIA demonstrates a successful example of collaborative European Research contributing to the EU 2020 CO₂ reduction objectives by enabling and demonstrating innovative IC products manufactured in Europe.

High costs, together with concerns for driving range, reliability and safety, are still the main hindrance for market adoption of full electrical vehicles (FEVs). The project ESTRELIA aims to provide building elements with enhanced reliability and safety at lowered costs for smart energy storage for FEVs. This will be accomplished through a modular approach based on optimized ultracapacitor power packs developed by Valeo. Corning will provide prototype ultracapacitor cells, projected with up to 50% energy density advantage over commercially available products. The performance of the power packs will be evaluated by Austrian Battery Research Lab.

New Battery Management (BMS) ICs from austriamicrosystems will, for the first time, provide a flexible active cell balancing chip set also suited for the high accuracy demanding monitoring of Li-Ion batteries.

The BMS ICs and architecture proposed from Fraunhofer IISB will be verified on prototypes built by E4V. Tests with new HV test equipment developed by Active Technologies will proof test isolation protections in the environment of several 100's V as present in FEVs. The new BMS IC concept will enable higher efficiency by lower energy loss and improved long term reliability and lower the electronic component costs for BMS of Li-Ion energy packs.

ESTRELIA will also develop new safety sensors, which are based on silicon based MEMS approaches delivering enhanced safety functions at lowered cost compared to existing solutions. While the gas sensor will allow detection of very low levels of volatile organic compounds as emitted in thermal overruns of battery packs, the new spark detector concept will enable general safety functions by flame detection from all hazardous events in a FEV. Finally, the development of new low cost power antifuses by Fraunhofer IISB together with the new energy management hardware (BMS IC) and software will enable dynamic reconfigurable topologies in the energy storage unit, thus providing limp-home functionality to the FEV despite single cell failures.

The consortium led by austriamicrosystems (AT) includes Valeo Electrical Systems (FR), Fraunhofer IISB (DE), Corning SAS (FR), Austrian Battery Research Laboratory (AT), AppliedSensor (DE), CEA LETI (FR), Active Technologies (IT), E4V (FR). All consortium partners are leaders in their respective areas of expertise. After six months of successful cooperation we are progressing very well with the so far achieved results. Our half year project team meeting was very productive and we have been able to solve open issues", stated Ewald Wachmann from austriamicrosystems, who leads the coordination team of ESTRELIA.

Based on several inputs from car manufacturers the IC specification and design for the Battery Management ICs is progressing very well. A detailed concept using self-triggered power antifuses to bypass faulty battery cells has been developed and supported by device simulation. This is a first step to provide a cost effective solution to single cell failure for the future. Also the development of the very important safety sensors for EV's is on schedule. For the new gas sensor the first modified samples for battery testing have been provided, and for the MEMS based spark detection sensor the appropriate piezo resistive concept has been selected and the design optimization is running. First samples of the ultracapacitor cell samples with high energy densities in the range of 7-9 Wh/L have already been investigated. By the end of the project, up to 50% higher energy density in the power pack is an intended innovation of the ESTRELIA project.

www.estrelia.eu www.austriamicrosystems.com (120209-1)

Infinion XMC4000 microcontroller family gets ARM® Cortex™-M4 processor tool support

Atollic TrueSTUDIO® for ARM® C/C++ development tool will be available shortly for the new 32-bit XMC4000 family of Infineon Technologies AG that uses the ARM Cortex™-M4 processor from launch. Infineon's XMC4000 line-up is targeted at a wide range of industrial applications, such as electric drives, solar inverters and the automation of manufacturing and buildings. The XMC4000 family will be launched at Embedded World 2012 in Nuremberg, Germany. With XMC4000 Infineon combines a full-featured configurable peripheral set with an industry-standard ARM Cortex-M4 core that is ideal for energy-efficient industrial applications. XMC4500, the first series of the new microcontroller family, delivers the 32-bit computing power embedded developers need to innovate a variety of industrial applications within time-constrained development cycles. Peripheral interface support includes SPI, I2C, UART and CAN configurable serial modules together with 12-bit ADCs and DACs.



The Atollic TrueSTUDIO for ARM development tool has recently been given the EDN Hot 100 products of 2011 award. Atollic TrueSTUDIO is a world-class development and debugging tool that offers a state-of-the-art editor, an optimizing C/C++ compiler and a multiprocessor-aware debugger with real-time tracing. The tool suite delivers a leap in software development team collaboration and developer productivity, and offers advanced features including ARM build and debug tools, system analysis and real-time tracing using Serial Wire Viewer (SWV) technology, and graphical-UML diagram editors for model-based design and architecture. Atollic TrueSTUDIO also offers multiple advanced features, such as: an ECLIPSE™-based IDE with a state-of-the-art editor; x86 C/C++ build and debug tools for development of PC command-line applications;

Advertisement

\$51^{For 3} PCBs

FREE Layout Software!
FREE Schematic Software!

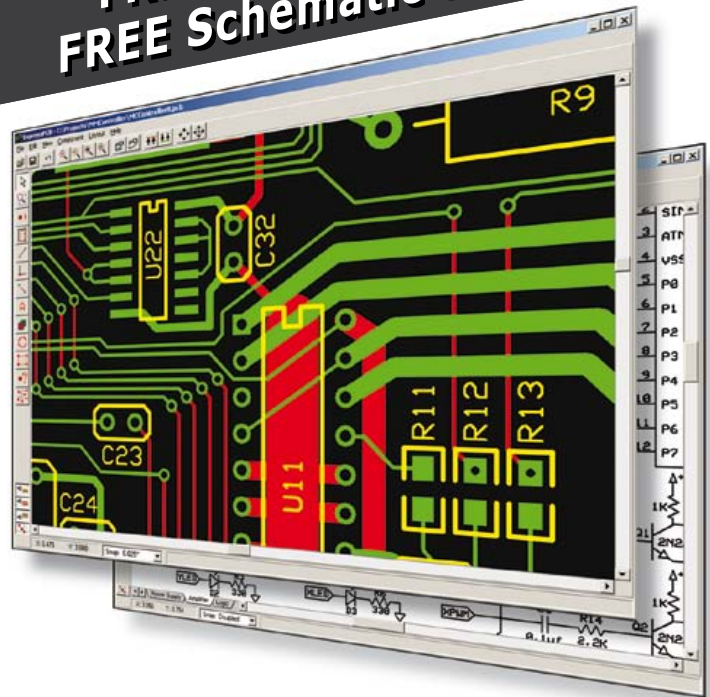

- 01 DOWNLOAD our free CAD software
- 02 DESIGN your two or four layer PC board
- 03 SEND us your design with just a click
- 04 RECEIVE top quality boards in just days

expresspcb.com

parallel compilation and multiprocessor debugging; and integrated version-control system client with revision graph visualization, enabling easy tracing of the history of code additions and revisions. Additionally, Atollic TrueSTUDIO includes an integrated client for accessing popular bug databases like Trac and Bugzilla, and it includes integrated features for performing source code reviews and code review meetings too. Atollic offers optional add-on modules that extend Atollic TrueSTUDIO with advanced

features for static and dynamic code analysis as well as automatic unit testing. TrueINSPECTOR® performs static source code analysis (MISRA®-C compliance control and code metrics), TrueANALYZER® performs in-target test quality measurement up to Modified condition/Decision coverage (MC/DC) using dynamic execution flow analysis, and TrueVERIFIER® performs automated in-target unit testing of the embedded software.

www.atollic.com (120202-IX)

Low Power, < 7ppm/°C guaranteed, 2.5 V voltage reference IC

Touchstone Semiconductor, a developer of high-performance analog integrated circuit solutions, today announced the newest member of its voltage reference family, the TS6001A, a low-power, low-dropout precision SOT-23 voltage reference IC that reduces drift to a guaranteed 7 ppm/°C maximum, a 2x improvement over its closest competitor, the MAX6025A.

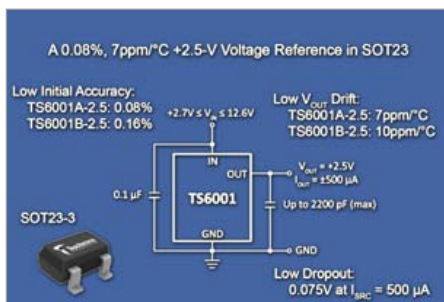

The unique combination of a small form factor, few external components and low supply current make the TS6001A an ideal choice for low-voltage, supply-independent, power-sensitive applications, including handheld and battery-operated equipment.

The TS6001A is capable of sinking and sourcing load currents up to 500 µA. The TS6001A consumes only 27 µA of supply current at no-load. It also offers an initial accuracy initial output voltage accuracy of less than 0.08%.

The TS6001A and TS6001B are available in a space-saving 3-pin SOT23 package. It is in stock and ready to ship. The product is in stock and available from Future Electronics.

www.futureelectronics.com

www.touchstonesemi.com/voltagereferences.html

(120202-X)

Cypress: high-voltage Tx drivers give touchscreens a boost

Cypress Semiconductor Corp. unveiled a breakthrough feature for its Gen4 TrueTouch® touchscreen controllers that dramatically improves system performance without added cost. Cypress has developed a new proprietary technology based on Gen4's patent-pending high-voltage Tx drivers. Tx-

Boost™ extends Gen4's performance leadership by delivering three times higher signal-to-noise ratio (SNR) than previously possible. This is accomplished without the use of performance-robbing digital filters or external components, enabling manufacturer's to produce the industry's thinnest handsets and tablets with low material costs.

The key to excellent touchscreen performance in noisy environments is high SNR. Gen4 already delivers up to four times the raw SNR of the competition through its internally generated 10 V Tx circuitry; whereas competitive offerings require customers to use large, expensive, and noisy external switching regulators to generate high-voltage Tx signaling. The Tx-Boost feature, now available on all TrueTouch Gen4 devices, uses specialized hardware acceleration to triple the already best-in-class SNR of the Gen4 family. This high SNR enables manufacturers to employ sensor-on-lens with direct lamination to displays and in-cell architectures with flawless performance for the thinnest products in the market.



In addition, Tx-Boost efficiently parallelizes multiple operations in hardware, without burdening the CPU with costly digital filtering. This significantly increases Gen4's scan speed, making the world's fastest touchscreen controller even faster. These parallel operations also further improve Gen4's industry-leading power consumption by increasing the amount of idle time during each scan period.

"We understand that touchscreen customers are in highly competitive markets and need constantly improving technology to stay ahead," said Dhvani Vyas, Vice President of Cypress's User Interface Business Unit. "We're pleased to provide Tx-Boost to enable the industry's best controller family to extend its leadership against competitive offerings. Customers who have seen this technology in action have been universally impressed." The Tx-Boost solution is now available on all Gen4 TrueTouch devices.

www.cypress.com (120209-2)

8051/80C51 legacy lives on with new Microchip microcontrollers

Microchip Technology Inc. is set to continue to manufacture legacy 8051/80C51 MCUs that provide pin-for-pin-compatible replacements for most of those recently placed under 'End-of-Life' (EOL) notification by NXP. Included are drop-in replacements for NXP's P89LV51RB2/C2/D2 and P89V51RB2/C2/D2 EOL series of 80C51 8-bit microcontrollers. Microchip's April



2010 acquisition of Silicon Storage Technology, Inc. (SST) included a legacy 80C51 MCU business, which Microchip has continued to support.

"Microchip has a history of supporting customers with long lifetimes on all of our product lines," said Randy Drwinga, vice president at Microchip Technology Inc. "We also have a strong presence in the industrial, automotive and medical markets, and understand that long-life-cycle product support is important to these customers. We welcome anyone currently using NXP's 80C51 MCUs who doesn't wish to redesign their end products to use our 100% compatible 80C51 product portfolio, and we offer them the option to migrate to our broad portfolio of 8-bit, 16-bit and 32-bit PIC® microcontrollers, at their convenience."

Microchip has a cross-reference document available on its Web site, as well as data sheets and a product brief. NXP's P89LV versions are 3 V MCUs, and are 100% compatible with Microchip's SST89V MCUs. Likewise, NXP's P89V versions are 5 V MCUs, and are pin-for-pin compatible with Microchip's SST89E microcontrollers.

As with all 8051-compatible microcontrollers, Microchip's 80C51 MCUs can be used with many third-party development tools that are widely available. Examples include programmers from Xeltek, Hi-Lo Systems, Advantech Equipment Corp.,

EETools and Phyton. Note that some third-party sites have these devices under "Manufacturer: SST."

www.microchip.com/get/18D1
www.microchip.com/get/SW8R
 (120209-3)

New adjustable output low dropout voltage regulators for automotive applications

ON Semiconductor has announced two new low dropout (LDO) voltage regulator ICs. Building on the company's market-leading power management portfolio for automotive applications, the new devices are ideal for use in audio and infotainment systems, instrument cluster, navigation and satellite radio. The new NCV47700 and NCV47701 LDOs feature an output diagnostic pin CSO that can be used to detect open and shorted loads. Using a resistor connected to the CSO provides an adjustable output current level between 10 milliamperes (mA) and 350 mA with $\pm 10\%$ accuracy. Tying the ADJ pin to ground configures the NCV47700 and NCV47701 to be a current limited high-side switch. High peak input voltage tolerance and reverse input voltage protection, as well as overcurrent and overtempera-



ture protection functions are all included to safeguard against the effects of the harsh operating conditions typical of automotive applications. An integrated current sense feature negates the need to implement a discrete solution that would use more board space and raise the total component count. Adjustable output voltage versions of the devices are available; these cover the 5 volt (V) to 20 V range, with $\pm 6\%$ accuracy for

the NCV47700 and $\pm 3\%$ accuracy for the NCV47701. Both new LDO voltage regulator ICs have a junction operating temperature range of -40°C to $+150^\circ\text{C}$, that matches or exceeds the specifications stipulated by the automotive industry.

"These feature-packed LDOs are differentiated from alternative market offerings by integrated current sensing functionality and an array of protection mechanisms," said Jim Alvernaz, director of the Automotive product division at ON Semiconductor. "The devices enable electronic design engineers to implement power management subsystem diagnostics, without the employment of a discrete current measurement circuit or additional protection components. This leads to improved power regulation in the audio/infotainment systems, instrumentation clusters and navigation systems found in modern vehicles."

www.onsemi.com (120209-5)

New ezLOAD PCB Support System



Count On Tools Inc., a leading provider of precision components and SMT spare parts, announces the release of its newly redesigned ezLOAD PCB support system with modular frame. With the recent increase of densely populated double-sided circuit boards, COT recognized the need for more affordable board support options in the electronics manufacturing industry. The end result is an innovative design that is not only easy to setup and install, but also offers industry-leading benefits to EMS companies and contract manufacturers worldwide. The newly redesigned ezLOAD PCB support system from COT features a new extruded aluminum base. The system not only reduces changeover times, but improves product build quality, increases revenues by providing significant cost savings, and can eliminate component damage during the assembly process.

BEST SCOPE SELECTION & lowest prices!

25MHz Scope

Remarkable low cost 25MHz 2 channel plus trigger USB bench scope with 8 inch full color LCD display. Spectrum analysis and autoscale functions.



PDS5022S \$279



iPhone Scope

5MHz mixed signal oscilloscope adapter for the iPhone, iPad and iPod Touch! A FREE iMSO-104 app is available for download from Apple App Store.

iMSO-104 \$297.99

100MHz Scope

High-end 100MHz 16Sa/s 2-channel benchscope with 1MSa memory and USB memory port. Includes a FREE scope carry case! New low price!



DS1102E \$399



60MHz Scope

60MHz 2 channel digital scope with a 500 MSa/s sample rate, 10MSa memory & 8" color TFT-LCD screen.

SDS6062 \$329

World's Smallest

The world's smallest MSO! This DIP-sized 200kHz 2 channel scope includes a spectrum analyzer and arbitrary waveform generator. It measures only 1 x 1.6 inches in size!



Xprotolab \$49



100MHz MSO

2 channel 100MSa/s oscilloscope and 8-ch logic analyzer USB 2.0 and 4M samples storage per channel with sophisticated triggering and math functions.

CS328A \$1359

Handheld 20MHz

Fast, accurate handheld 20MHz 1-ch oscilloscope.
 - 100 M/S sample rate
 - 3.5 in. color TFT-LCD
 - 6 hour battery life
 Inc. rugged impact-resistant case



HDS1021M \$269.95

More selections at:

www.saelig.com



Saelig.com
 unique electronics



COT's new ezLOAD features active grip technology to securely hold boards during the assembly process. It protects components while allowing the boards to move freely through the assembly line. Also, with the basic universal design, there are no mechanical functions to fail. The system requires no air, electronics, or communication from the user. The magnetic locking base enables a quick and easy installation. Other base designs are available for non-magnetic tables. Most importantly, the ezLOAD PCB support system is affordable compared to competitive products on the market.

The ezLOAD PCB support system is compatible with any SMT equipment, from pick-and-place to chipshooters, screen printers, dispensers, AOI, and more. It is extremely durable thanks to the soft, flexible design, and is proven to be reliable after testing in the most hazardous conditions. The ezLOAD PCB support system is customizable depending on machine requirements, specialized components, or specific design application requirements.

www.cotinc.com/ezload (120209-4)



Verotec: Eleven new integrated development systems

Verotec has developed eleven new models in four families of integrated development systems for stand-alone desktop or rack mount environments. Equally suitable for the hardware/software development environment and for use as the packaging for the finished system, the modular units are configured from the company's standard ranges of enclosures, subracks, backplanes, thermal management products and power supplies. The use of standard building blocks reduces the developer's time to market; all systems are user-configurable around the default options if required. cPCI, VME and VME64x are fully supported in all models.

The D10 and D21 are desktop half- and full-width systems, supporting 6U 10 and 21 Slot cPCI and VME64x systems respectively. 9U high, space for 80 mm deep rear transition modules is provided as standard and cooling fans are mounted below the IEEE1101.10/11 KM6-RF subrack. The V8, V9 and V12 are 8U, 9U and 12U 21 Slot systems based on the KM6-II and KM6-RF subracks. Designed for rack mounting 6U cPCI and VME64x systems, all variants have inte-

gral thermal management; in the V8 and V9 models a removable fan tray is mounted beneath the subrack, in the V12 an extractor fan unit mounted in the rear of the unit augments the airflow through the boards. Both embedded and pluggable PSUs are supported in the D and V units.

The H Series is designed around the IEEE1101.10/11 KM6-HD heavy duty subrack for horizontal mounting of 6U cPCI or VME64x boards. The H12 is 1U high with 2 slots, the H24 2U high with 4 slots and the H36 3U high with 6 slots; all versions support full width rear transition modules. The cooling arrangements vary between models, but all versions have both front and rear area cooling. Good EMC performance is achieved by the use of fabric-over-foam and beryllium copper gaskets and optimized hole diameter and spacing on the intake and exhaust cooling vent matrices. A range of different PSUs is supported. The TecSYS system is an entry-level VPX development platform to provide a basic physical environment for software development and board integration. Configured around a 5-slot 3U full mesh X4 PCI Express VITA 46.4 backplane with VITA 46.10 RTM

capability, the 6U half-width desktop system provides fat pipe communications between all five slots and an interface with one of the most widely used architectures, PCI Express.

www.verotec.co.uk (120209-6)

New 200W AC to DC modules

Acal BFi, a division of Acal plc, recently launched a new range of embedded power supplies from specialist manufacturer, SL Power, which feature 90% efficiency and one of the smallest heat footprints in AC to DC conversion.

The CINT1200 family comprises eight models with output voltages from 12 V to 48 V, and up to 200 watts of output power, from a wide input range of 90 V to 264 Vac. The space-saving CINT1200 AC to DC modules measure 3" (7.6 cm) x 5" (12.7 cm), with a height of just 1.3" (3.3 cm), allowing them to easily fit into a 1U chassis.

Designed to meet the stringent EMC requirements for industrial and information technology equipment (ITE) applications, the CINT1200 modules are HALT tested for durability and offer a 3-year warranty. The modules are CE marked in accordance with the low-voltage directive and are approved to ITE standards making them suitable for



worldwide applications. Value-add manufacturing services allow Acal BFi to modify or produce full custom versions of SL Power modules, including in-house testing for EMC, fast prototyping and a low minimum order quantity.

www.acaltechnology.com/uk/slpower2
(120202-VII)

Add μ Blue to your Bluetooth Smart application

Ultra low power (ULP) RF specialist Nordic Semiconductor recently released its brand new μ Blue™ nRF8002 System-on-Chip (SoC) that provides a low cost, ultra-low power, uniquely easy to design-in single chip solution for Bluetooth Smart (as Bluetooth low energy will now be marketed to consumers) wireless tags and other accessories such as bracelets, pendants, keychains, small toys, and armbands.

To add the μ Blue™ nRF8002 to a product design demands no specialist understanding of Bluetooth low energy wireless technology or any embedded firmware development. Using a Nordic nRFgo-compatible nRF8002 Development Kit, developers can design Bluetooth Smart tags and accessories using a simple graphical user interface that allows them to go no deeper than configuring the built-in application layer and mapping inputs and outputs to external components such as buttons, LEDs, and buzzers. The development kit even includes a small coin cell-powered tag design example that can be used for development, prototyping, and testing.

The nRF8002 is supplied in a compact 5x5mm QFN package and includes a fully-qualified Bluetooth v4.0 low energy protocol stack, a highly configurable application layer, and built-in support for a range of Bluetooth v4.0 profiles including: Find Me, Proximity, Alert Notifications, and Battery Status. This — combined with market-leading power consumption — makes the nRF8002 an ideal solution for low cost, miniaturized coin cell battery-powered applications. The Find Me profile allows users to pair small — but commonly misplaced — everyday objects with their Bluetooth v4.0 smartphone in order to locate either from the other. In a similar way to how people often phone their misplaced cell phones to make them ring and easy to find, a small nRF8002-based Bluetooth Smart tag attached to a keychain, for example, can feature an audible alarm that can be activated if the keys are misplaced by a pressing a button on a smartphone. Alternatively a misplaced smartphone could be made to ring or alarm by pressing a button on the tag. The Proximity profile adds further out-of-range functionality to the Find Me profile to allow users to pair valuable everyday Bluetooth v4.0 objects (e.g. smartphones and computers) with, for example, a wireless tag so that it alarms or securely locks the valued item if the user and item are separated by more than a specified distance (e.g. due to the user leaving the office, potentially leaving the item behind at a public place, or the item being stolen). Alternatively, the Proximity profile can also be used to automatically activate (unlock) a smartphone or computer when the user is within a specified distance (so saving the hassle and security risk of having to enter unlock passcodes manually). The Alert Notification profile allows users to be notified of specific events happening on a paired Bluetooth v4.0 device. This means, for example, an nRF8002-based sports armband could be set to vibrate if the user receives an incoming call from a specific person(s) while working out at the gym or running outdoors.

The Battery Power profile enables users to be given low battery warnings. This means a Bluetooth v4.0 smartphone could, for example, alert users of the need to change the battery in any of their paired Bluetooth Smart wireless accessories — from heart-rate belts and foot pods through to remote controls, wireless mice, and keyboards. The Nordic nRF8002 is built on the same technology platform as its nRF8001 predecessor and so provides many of the same key technical performance and feature advantages including:

- Peak currents as low as 13mA;
- Months to years of battery lifetime from a single coin cell battery (depending on duty cycle);
- Ultra-low power operation without the need for an external 32 kHz crystal;
- An on-chip battery monitor.

Samples of the nRF8002 are available now, along with the Nordic nRFgo compatible nRF8002 Development Kit (priced at USD \$99) that enables engineers to quickly evaluate, test, and prototype Bluetooth Smart applications using the nRF8002.

www.nordicsemi.com (120209-7)



BitScope

Digital + Analog



100 MHz Digital Oscilloscope

Dual Channel Digital Storage Oscilloscope with up to 12 bit analog sample resolution and high speed real-time waveform display.

40 MSPS x 8 Channel Logic Analyzer

Captures eight logic/timing signals together with sophisticated cross-triggers for precise multi-channel mixed signal measurements.

Serial Logic and Protocol Analyzer

Capture and analyze SPI, CAN, I2C, UART & logic timing concurrently with analog. Solve complex system control problems with ease.

Real-Time Spectrum Analyzer

Display analog waveforms and their spectra simultaneously in real-time. Baseband or RF signals with variable bandwidth control.

Waveform and Logic Generators

Generate an arbitrary waveform and capture analog & digital signals concurrently or create programmable logic and/or protocol patterns.

Multi-Channel Chart Recorder

Record to disk anything BitScope can capture. Allows off-line replay and waveform analysis. Export captured waveforms and logic signals.

Protocol Analyzer



Digital Oscilloscope

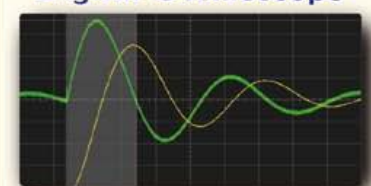

Spectrum Analyzer



Compatible with major operating systems including Windows, Linux & Mac OS X, Pocket Analyzer is your ideal test and measurement companion.



bitscope.com/us



DESIGNSPARK

WINNERS ANNOUNCED ON MAY 7!

Turn a
hot idea
into a
cool solution.

It is time.

March 27 marks the end of the
DesignSpark chipKIT™ Challenge!

Soon, your eco-friendly and energy efficient design solutions will be in the hands of Elektor and Circuit Cellar's expert panel of judges.

Did you have what it takes to unleash the low-power combination of DesignSpark's free PCB software and Microchip Technology's chipKIT™ Max32™ development board? **Find out on May 7, 2012 when the Grand Prize Winners will be announced.**



\$10,000 in cash prizes!



Visit www.chipkitchallenge.com

IN ASSOCIATION WITH:



chipKIT™ is a registered trademark of Microchip Technology Inc.

Max32™ is a registered trademark of Digilent, Inc.

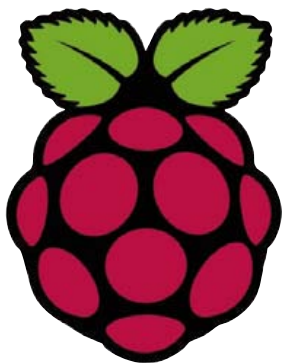

What are you Doing?

The Raspberry Pi \$25 computer

By Wisse Hettinga (Elektor UK/INT Editorial)

Raspberry Pi is grabbing the attention with a \$25 computer (\$35 for a networked model). In the middle of the storm is Eben Upton. Why is he convinced that a computer with no casing, no keyboard, no hard disk and no screen, will be successful? It's time to put the question to him: "What are you Doing?"

There is no reason why a computer should cost more than 50 dollars'

Wisse: Whence the name?

Eben: We wanted to have a computer especially for Python, and there is a great tradition of naming computers after fruit: like Apricot, Acorn and even today there are computers named after fruit. So Raspberry is following the line of a rich tradition with the Pi, and yes, we wanted this connection with Python. That is where the Pi comes in.

Wisse: And why is it a charity that brings this computer to the market?

Eben: That all has to do with value creation. I've been involved in several start-ups and then you always end up with the question; how will this create value? In this case I do not have to worry about creating value. I can concentrate on designing and producing the board. The Raspberry Pi can be seen as a 'white label' product. If there are people out there with a commercial idea for this product, they are more than welcome.

Wisse: The Raspberry Pi is a bare PC board; no keyboard, no HD, no screen... how will this product become successful?

Eben: Basically, there is no reason why a computer has to cost more than \$50. The peripherals like a screen and keyboard and storage will create a higher price, but with the Raspberry Pi we have taken another route — a normal TV can be used as a screen. Combine that with a 'charity shop' keyboard for a few dollars and you have a full working system. The Raspberry is specifically aiming at youngsters learning to program.

Wisse: And how about the Raspberry Pi being 'the next big thing' after Arduino? There are many hints in that direction on the Internet?

Eben: The Raspberry Pi is different from the Arduino. The Arduino is great for direct applications and there are dozens of programs available. The Raspberry Pi is a computer system — designed to work with a screen and keyboard, a completely different idea. You can even watch videos with this thing. What might be interesting is the possibility to use the Raspberry Pi as a host for the Arduino board — the combination of these two, resulting in low priced systems can be very interesting and useful.

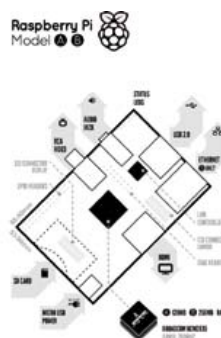

There is also a difference between flexibility and usability. We have chosen for Broadcom chips and they are not easy to get in the market, making it very difficult to call the Raspberry Pi an 'open source' project. We are hoping to take this development into the open source direction, but that will require a new design.

Wisse: Can designers use the Raspberry Pi for different applications?

Eben: Yes, no problem. There is plenty of I/O (I²C and UART) to start using it for whatever challenges you want to take on.

Wisse: The first batch of 10,000 Pi's has arrived from the factory — what will be the next step?

Eben: Another 10,000 we hope and that is all just the start of it...

Eben Upton is a Founder and Trustee of the Raspberry Pi Foundation, he is responsible for the overall software and hardware architecture of the Raspberry Pi.

(120228)

The Raspberry is specifically aimed at youngsters learning to program

Preamplifier 2012 (1)

Part 1: introduction and line-in/tone/volume board



By Douglas Self (UK)

Audio lovers, sit up. Besides presenting a truly high end audio control preamplifier for home construction, this article series also aims to show how low-impedance design and multiple-amplifier techniques can be used to significantly reduce the noise levels in analog circuitry. The result of the design effort is a top-notch preamp that's brilliant not just sonically but also in terms of cost/performance ratio.

It is now some time since I published a pre-amplifier design — the Precision Preamp in 1996 [1]. Inevitably technology has moved on. In that design the recording output level was as low as $150 \text{ mV}_{\text{rms}}$ to get a good disc input overload margin, the amplitude being well within the reach of the average tape recorder input level control. Nowadays most audio line inputs will be from digital sources, typically at 1 V_{rms} unbalanced or 2 V_{rms} balanced, and recognition of that requires a completely new design, especially in the MM/MC phono section.

The preamplifier described here demonstrates how very low noise levels can be achieved in analog circuitry without using exotic parts. It was originally conceived as being entirely made up of 5532 opamps, like the earlier Elektor 5532 *OpAmplifier* [2] but during the design process it became clear that adding a few LM4562s (which are now a good deal cheaper than they used to be) would avoid some awkward compromises on distortion performance, because of their superior load-driving ability. In addition, the preamplifier has a very versatile MC/MM phono input stage with gain-switching, which I believe can optimally handle any cartridge on the market; this is

guided by an innovative level indicator that provides more information than just on/off from one LED and does away with the need for bar-graph metering.

A block diagram of the proposed preamplifier is shown in **Figure 1**. In practice, the project is divided into several circuit boards, each of which will be discussed separately starting this month with the circuitry comprising the line amplifier, tone control, volume control, and output stage.

Noise of three kinds

There are three main causes of electronic noise in analog circuitry: Johnson noise from resistors, and current and voltage noise from semiconductors.

All resistances (including those forming an integral part of other components, such as the base spreading resistance of a bipolar transistor) generate **Johnson noise** at a level that depends on the resistance and the absolute temperature. There is usually little you can do about the ambient temperature, but the resistance is under your control. Johnson noise can therefore be minimized by Low Impedance Design, in other words keeping the circuit impedances as low as possible.

In the early 1970s audio circuitry commonly used $25 \text{ k}\Omega$ or $50 \text{ k}\Omega$ potentiometers and associated components of proportionally high impedance, mainly because the discrete transistor circuitry of early opamps used had poor load-driving abilities. When the (NE)5532 appeared, and equally importantly, came down to a reasonable price, it was possible to reduce impedance levels and use $10 \text{ k}\Omega$ pots. This may not seem very ambitious when you consider that a 5532 can drive about 800Ω while keeping its good distortion performance, but the pot value does not always give a good idea of, for example, the input impedance of the circuit block in which it is used. It is not widely known that a standard Baxandall tone control constructed with two $10 \text{ k}\Omega$ pots has an input impedance that can easily fall to less than $1 \text{ k}\Omega$. There is a cunning way round this problem; the Bass and Treble tone control networks can be driven separately; more on this below.

Fixed resistors are available in almost any value, but the pot values available are much more restricted, and the lowest practical value in that two-gang pots are available for stereo, is $1 \text{ k}\Omega$.

Volume/Balance/Tone Control Board Performance

Test conditions: supply voltage $\pm 17.6\text{ V}$; all measurements symmetrical; tone control defeat disabled.

Test equipment: Audio Precision Two Cascade Plus 2722 Dual Domain (@Elektor Labs)

| | | | |
|----------------------------|---|---------------------------------|--|
| THD+N (200 mV in, 1 V out) | 0.0015% (1 kHz, B = 22 Hz – 22 kHz) 0.0028% (20 kHz, B = 22 Hz – 80 kHz) | Max. output voltage (200 mV in) | 1.3 V |
| THD+N (2 V in, 1 V out) | 0.0003% (1 kHz, B = 22 Hz – 22 kHz) 0.0009% (20 kHz, B = 22 Hz – 80 kHz) | Balance | +3.6 dB to -6.3 dB |
| S/N (200 mV in) | 96 dB (B = 22 Hz – 22 kHz) 98.7 dBA | Tone control | $\pm 8\text{ dB}$ (100 Hz) $\pm 8.5\text{ dB}$ (10 kHz) |
| Bandwidth | 0.2 Hz – 300 kHz | Crosstalk R to L | -98 dB (1 kHz) -74 dB (20 kHz) |
| | | Crosstalk L to R | -102 dB (1 kHz) -80 dB (20 kHz) |

Current noise is associated with opamp inputs. It only turns into voltage noise when it flows through an impedance, so it can be reduced by Low Impedance Design. The use of low value pots also means that opamp bias currents create less voltage drop in

them and so there are less likely to be intrusive noises when the wiper is moved.

Voltage noise is the third type of noise. It is already in voltage format, being equivalent to a voltage noise generator in series

with the opamp inputs, and so cannot be reduced by Low-Impedance Design. At first it seems that the only thing that can be done to minimize it to use the quietest opamps available. Opamps exist that are quieter than the 5532 or the LM4562, but

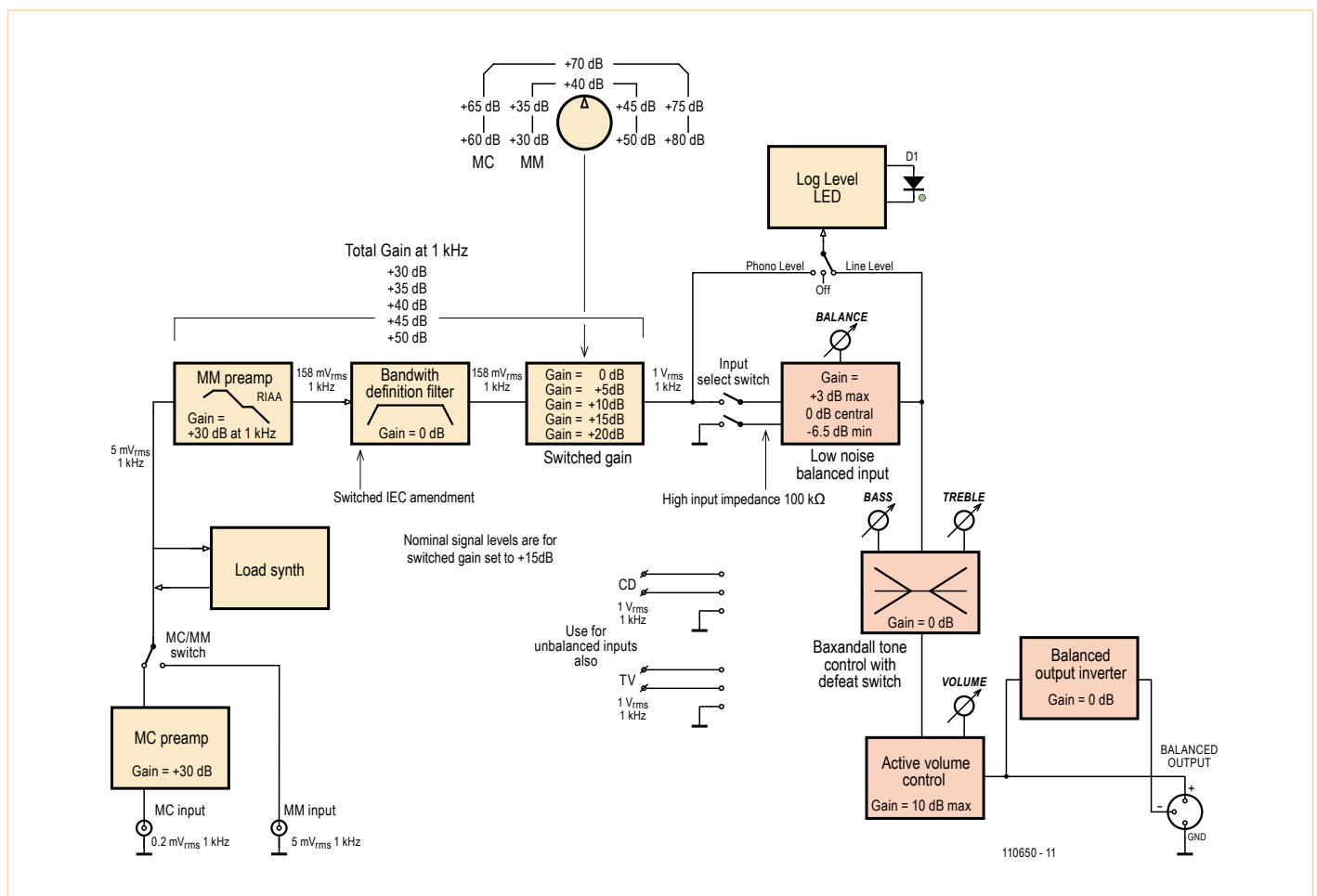

Figure 1. Architecture of the Preamplifier 2012. Although functions appear as individual blocks here, several of these are comprised together on circuit boards, for example, the four orange-colored blocks discussed in this article, i.e. from line input, through tone control, volume control up to balanced output.

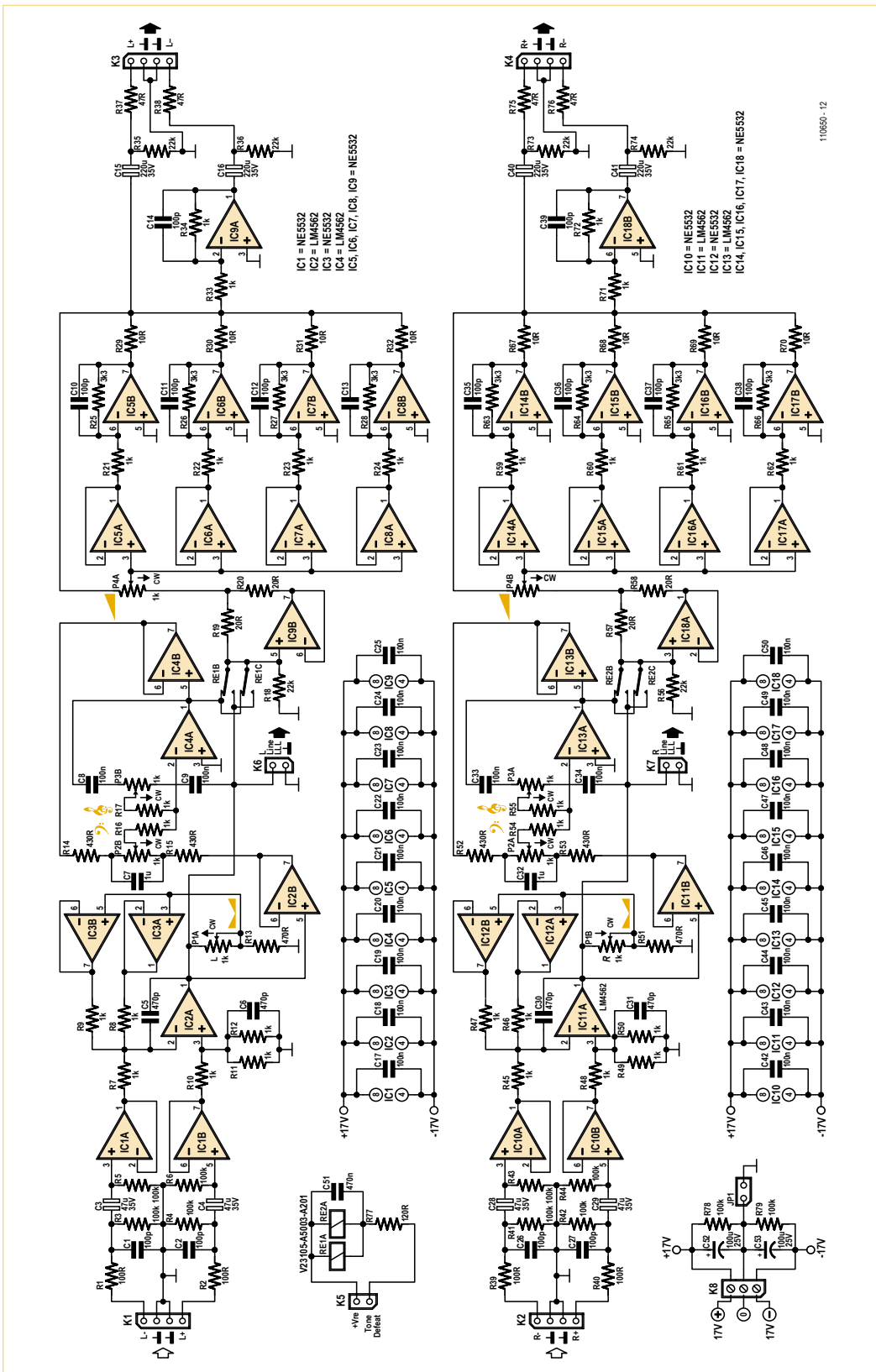
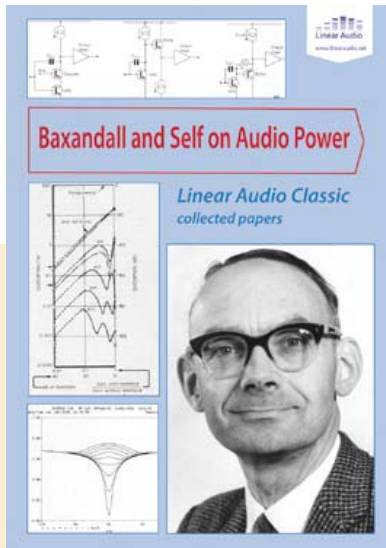

Figure 2. The circuit diagram of the line / tone / volume / output board is largely dominated by NE5532 and LM4562 opamps for good reasons. Note the unusually low value of the potentiometers used.

they are expensive and have high current noise. A typical example is the AD797, which has the further drawback of only being available in a single package, putting the cost up more.

A better path is the powerful technique of using of multiple cheap amplifiers with their outputs summed – or to be more accurate, averaged. With two amplifiers connected in parallel, the signal gain is unchanged. Their outputs are averaged simply by connecting a low value resistance to each amplifier and taking the output from their junction. The two noise sources are uncorrelated, as they come from physically different components, so they partially cancel and the noise level drops by 3 dB ($\sqrt{2}$). The amplifier outputs are very nearly identical, so little current flows from one opamp to another and distortion is not compromised. The combining resistor values are so low (typically 10 Ω) that their Johnson noise is negligible. This strategy can be repeated by using four amplifiers, giving a signal-to-noise improvement of 6 dB, eight amplifiers give 9 dB, and so on. Obviously there are limits on how far you can take this sort of thing. Multiple opamps in parallel are also very useful for driving the low impedances of Low Impedance Design, so the two techniques work beautifully together. The *Elektor 5532 OpAmp* [2] pretty much took this to its logical conclusion.

The multiple-amplifier approach gets unwieldy when the feedback components around each amplifier are expensive or over-numerous.



Peter Baxandall

I have tried hard in this project to design the highest performance preamplifier possible, and it is significant that in two out of the three stages, ideas put forward by Peter Baxandall have proved to be the best solution. He was a great man.

Editor's Note. Besides reprints of selected articles from *Wireless World* / *Electronics World*, Jan Didden's book "Baxandall and Self on Audio Power" presents a previously unpublished exchange of letters between Peter Baxandall and Douglas Self, both correspondents actively tracing the various causes of distortion in high end audio power amplifiers.

The book is published by Linear Audio, www.linearaudio.net.

To use two amplifiers in a standard Baxandall tone control you would have to use quad-gang rather than dual pots for stereo, and also duplicate all the resistors and capacitors. While this would reduce the effect of all the noise mechanisms in the circuit by $\sqrt{2}$, giving a solid 3 dB improvement, it is not an appealing scenario.

If instead you simply halved the impedance of the Baxandall network by halving the pot and resistance values and doubling the capacitor values, the situation is not equivalent. In the second case you have halved the effect of the opamp current noise flowing in the circuit impedances, and reduced the Johnson noise by root-two, but the opamp voltage noise remains unaffected and will often dominate.

Line input and balance control stage

This is a balanced input stage with gain variable over a limited range to implement the balance control function. Maximum gain is +3.7 dB and minimum gain -6.1 dB, which is more than enough for effective balance control. Gain with balance central is +0.2 dB. Looking at the circuit diagram in **Figure 2** and discussing the left (L) channel only, IC2A is the basic balanced amplifier; it is an LM4562 for low voltage noise and good driving ability. The resistances around it are low to reduce noise so it is fed by unity-gain buffers IC1A/B which give a high input impedance of 50 k Ω that improves the CMRR. Note the EMC filters R1-C1 and R2-C2 and the very start of the circuitry. The stage gain is set by 1 k Ω pot P1A, the negative feedback to IC2A being applied through two parallel unity-gain buffers IC3A/B so the variation in output impedance of the gain-control network will not degrade the CMRR. The dual buffers reduce noise and give also more drive capability. In this stage combining the buffer outputs is simple because the feedback resistance can be split into two

halves; R8 and R9. This requires R11 and R12 to be paralleled to get exactly the right resistance value and so preserve the CMRR. The noise output of this stage is very low: -109 dBu with the balance control central; -106 dBu at maximum gain and -116 dBu at minimum gain. (all 22 Hz - 22 kHz, rms)

The tone control stage

It is not obvious but this is (mostly) a conventional Baxandall tone-control. Once more 1 k Ω pots are used, requiring large capacitors to set the turnover frequencies, C7 at 1 μ F sets the bass frequency and C8, C9 at 100 nF set the treble frequency. The cut/boost is ± 10 dB maximum for both. The stage has a low input impedance, especially when set to boost; to deal with this the Bass and Treble parts of the tone-control network are driven separately. The Treble network C9-P3B-C8 is driven directly by IC2A in the previous stage, while the Bass network R15-C7-P2B-R14 is driven separately by the extra unity-gain buffer IC2B, the other half of the LM4562 in the line input stage. I call this a split-drive Baxandall circuit.

The Treble network is the two-capacitor version rather than the one-capacitor types; this has the advantage that the treble pot is uncoupled from the circuit at low frequencies and reduces the loading.

The main tone-control opamp is IC4A, which drives the Treble feedback path directly, while unity-gain buffer IC4B gives separate drive to the Bass feedback path. Polypropylene capacitors are strongly recommended as they are free from distortion while polyester types show significant non-linearity. Unfortunately they are also physically larger and more expensive, but well worth it in my view.

The noise output of the tone-control stage alone is only -113 dBu with controls set to flat.

Relays RE1 and RE2 implement a tone control defeat function by enabling the active volume control stage to be driven directly from IC2A. To prevent clicks and other noises when the relays switch over, R18 and R58 have been added, effectively keeping up the bias to IC9B and IC18A. To keep crosstalk down to a minimum each channel has its own relay. As a bonus, two contacts can be connected in parallel, preventing any risk of signal degradation and at the same time increasing life span.

Active volume control stage

The volume control is of the active Baxandall type which gives low noise at low volume settings and also synthesizes a quasi-logarithmic control law from a linear pot, giving much superior channel balance. Maximum gain is +16 dB, with 0 dB obtained with the control central. The input impedance of the volume control stage, implemented with another 1 k Ω pot P4A, falls to low values at high volume settings. It is therefore driven by the 'load-splitting arrangement' where buffer IC9B provides half of the drive from the tone-control stage. Resistors R19, R20 ensure that IC4A and IC9B share the load between them.

The conventional Baxandall active volume control as in [1] uses a single buffer and one inverting amplifier, such as IC5A and IC5B. Here four of these circuits are used in parallel to reduce noise by partial cancellation of the uncorrelated noise from the four amplifier paths, and to give sufficient drive capability to drive the back end of the 1 k Ω volume pot. The use of four paths reduces the noise by 6 dB. The multiple shunt amplifiers have no common-mode voltage on their inputs and so no CM distortion, and the associated buffers handle less than a third of the output voltage so stage distortion is very low. The enhanced drive capability means that it is not necessary to resort to LM4562s which still get a little expensive if

COMPONENT LIST

Resistors

(1% tolerance; metal film; 0.25W)

R1,R2,R39,R40 = 100Ω
 R3-R6,R41-R44,R78,R79 = 100kΩ
 R7-R12,R16,R17,R21-R24,R33,R34,
 R45-R50,R54,R55,R59-R62,R71,R72 = 1kΩ
 R13,R51 = 470Ω
 R14,R15,R52,R53 = 430Ω
 R18,R35,R36,R56,R73,R74 = 22kΩ
 R19,R20,R57,R58 = 20Ω
 R25-R28,R63-R66 = 3.3kΩ
 R29-R32,R67-R70 = 10Ω
 R37,R38,R75,R76 = 47Ω
 R77 = 120Ω

P1,P2,P3,P4 = 1kΩ, 10%, 1W, stereo potentiometer, linear law, e.g. Vishay Spectrol cermet type 14920F0GJSX13102KA. Alternatively, Vishay Spectrol conductive plastic type 148DXG56S102SP (RS Components p/n 484-9146).

Capacitors

C1,C2,C10-C14,C26,C27,C35-C39 = 100pF 630V, 1%, polystyrene, axial
 C3,C4,C28,C29 = 47μF 35V, 20%, bipolar, diam. 8mm, lead spacing 3.5mm, e.g. Multi-comp p/n NP35V476M8X11.5
 C5,C6,C30,C31 = 470pF 630V, 1%, polystyrene, axial

C7,C32 = 1μF 250V, 5%, polypropylene, lead spacing 15mm
 C8,C9,C33,C34 = 100nF 250V, 5%, polypropylene, lead spacing 10mm
 C15,C16,C40,C41 = 220μF 35V, 20%, bipolar, diam. 13mm, lead spacing 5mm, e.g. Multi-comp p/n NP35V227M13X20
 C17-C25,C42-C50 = 100nF 100V, 10%, lead spacing 7.5mm
 C51 = 470nF 100V, 10%, lead spacing 7.5mm
 C52,C53 = 100μF 25V, 20%, diam. 6.3mm, lead spacing 2.5mm

Semiconductors

IC1,IC3,IC5-IC10,IC12,IC14-IC18 = NE5532, e.g. ON Semiconductor type NE5532ANG
 IC2,IC4,IC11,IC13 = LM4562, e.g. National Semiconductor type LM4562NA/NOPB

Miscellaneous

K1-K4 = 4-pin straight pinheader, pitch 0.1" (2.54mm), with mating sockets
 K5,K6,K7 = 2-pin pinheader, pitch 0.1" (2.54mm), with mating sockets
 JP1 = 2-pin pinheader, pitch 0.1" (2.54mm), with jumper
 K8 = 3-way PCB screw terminal block, pitch 5mm

RE1,RE2 = relay, 12V/960Ω, 230VAC/3A, DPDT, TE Connectivity/Axicom type V23105-A5003-A201
 PCB # 110650-1

Note: all parts available from Farnell (but not exclusively), except PCB 110650-1

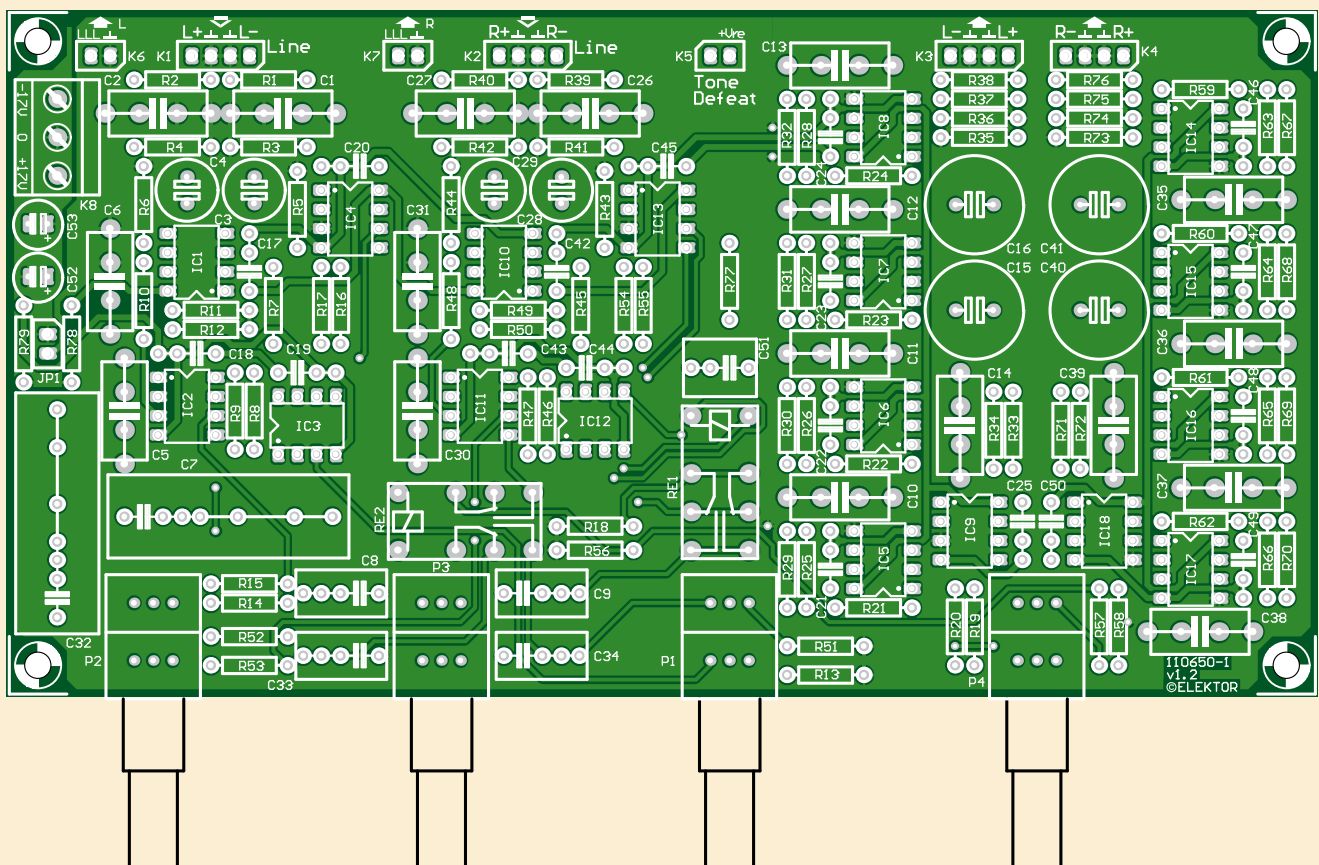

Figure 3. Component overlay of the circuit board designed by Elektor Labs for the line / tone / volume / output section of the Preamplifier 2012. Ready made boards may be ordered at www.elektorPCBservice.com.

you are using a lot of them. Four $10\ \Omega$ resistors R29-R32 are used to average the four outputs.

At sustained maximum sinewave output (about $10\ V_{\text{rms}}$) the volume pot gets perceptibly warm, as a consequence of the Low-Impedance Design approach. This may appear alarming but the heating is well within the specification of the hotpot. This does not occur with music signals.

The noise output of the active volume stage alone is $-101\ \text{dBu}$ at maximum gain and $-109\ \text{dBu}$ for $0\ \text{dB}$ gain. For low gains around $-20\ \text{dB}$, those most used in practice, noise output is about $-115\ \text{dBu}$. Rather quiet.

Here I have quoted the noise performance for each stage separately, to demonstrate

the noise-reduction techniques. In a complete preamplifier the noise levels add up as a signal goes through the system, though how this happens depends very much on the control settings.

Balanced output stage

The balanced output consists simply of a unity-gain inverter IC9A which generates the cold (phase-inverted) output. The balanced output is therefore at twice the level of the unbalanced output, as in normal hi-fi practice.

Construction notes

The project employs standard leaded components throughout. A high quality circuit board designed by Elektor Labs for the

project is available through www.elektor-PCBservice.com. The component overlay appears in **Figure 3**.

It is recommended to use a flip over type PCB jig. Start with low-profile components and finish with the taller ones.

The finished board pictured in **Figure 4** should be taken as an example to work from — success is guaranteed if you strive to achieve this level of perfection in construction.

Do not forget to fit JP1 for the ground through connection, a similar jumper is present on the MC/MM board. This allows you to determine empirically which ground

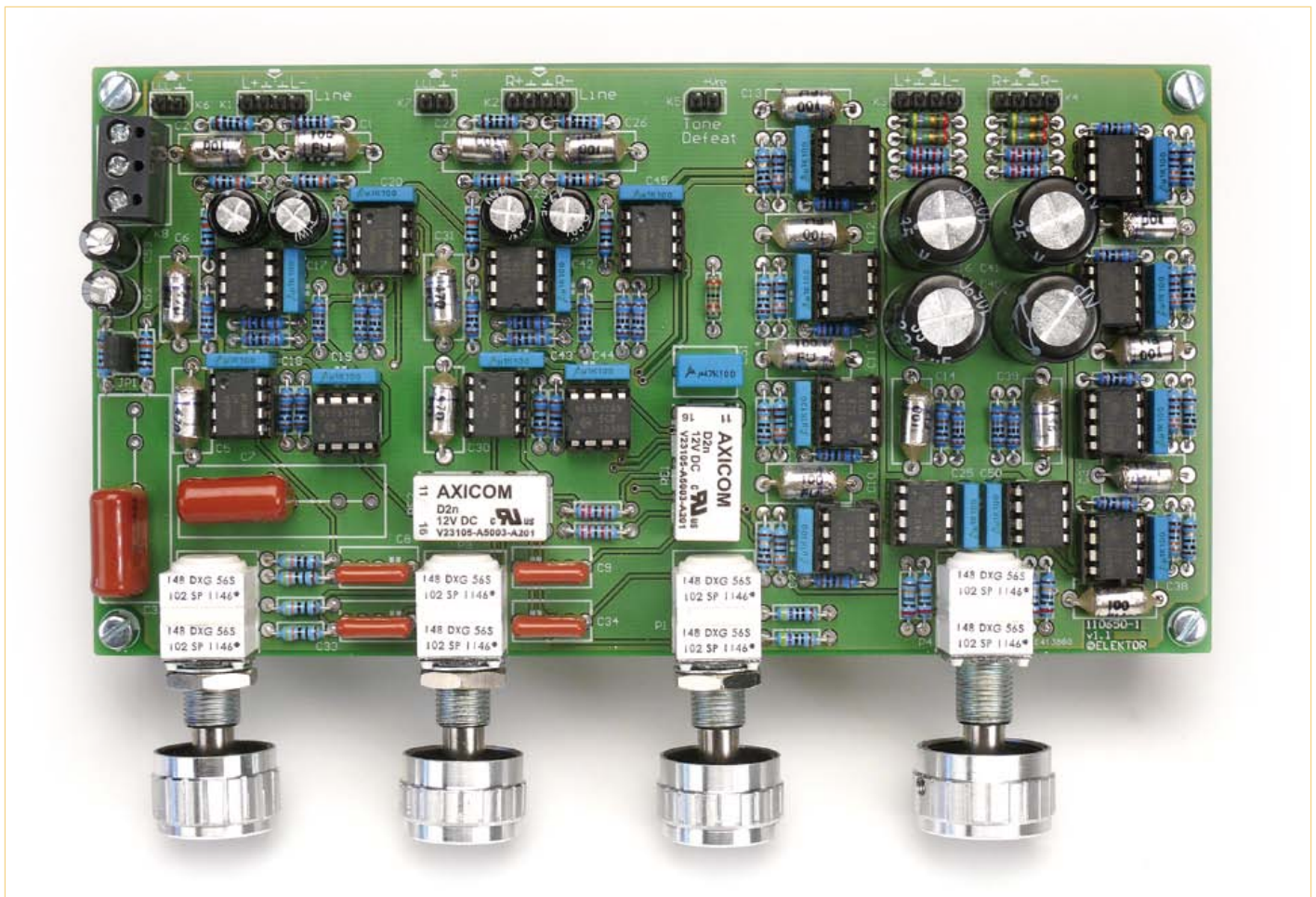

Figure 4. The prototype of the line / tone / volume / output board impeccably built by Elektor Labs.

Selected performance graphs

Line / tone / volume / output board # 110650-1 only.

Test equipment: Audio Precision Two Cascade Plus 2722 Dual Domain (@Elektor Labs)

All measurements symmetrical.

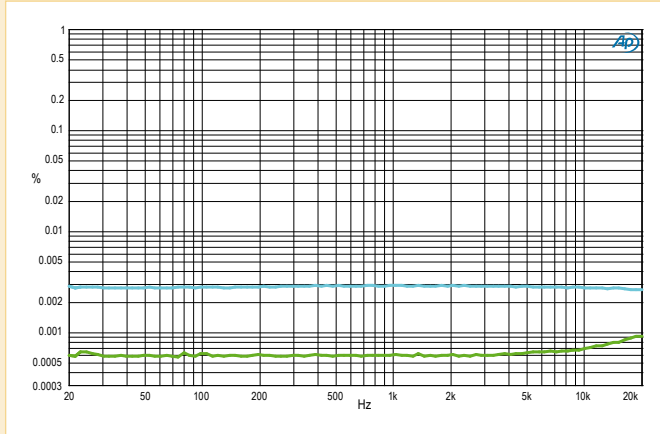

THD+N vs. Frequency. Measurements at 200 mV in and 2 V in (lower curve) and 80 kHz bandwidth. 1 V out. At 200 mV in there is noise only (approx. 96 dB measured at 22 kHz BW), and even lower levels at 2 V. Distortion not evident until above a few kHz.

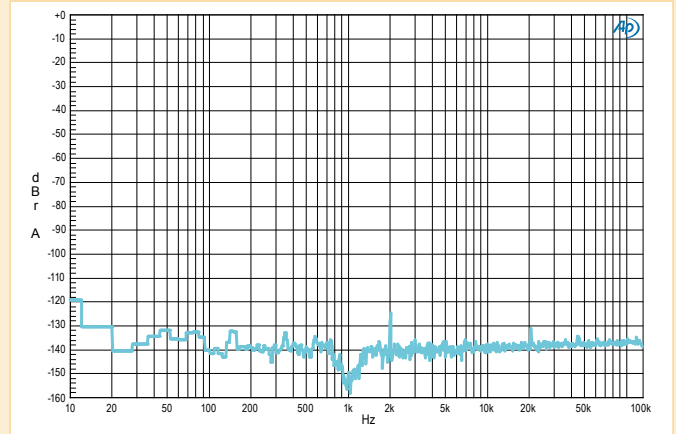

FFT of 1 kHz at 2 V in and 1 V out. Only second harmonic visible at -125 dB.

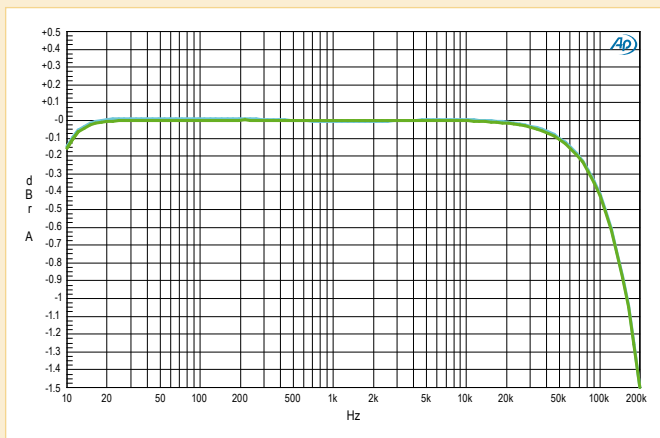

Amplitude vs. Frequency. Note the resolution on amplitude scale is just 0.1 dB. Tone defeat enabled. However, identical response obtained with tone control enabled and controls at mid position.

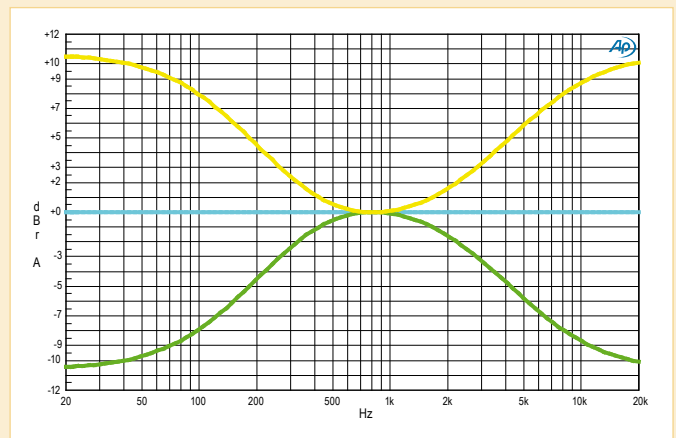

Response at max, min, and center positions of tone control (3 curves). Bass and treble set to identical extreme positions.

connection works best. When the wiring is complete one jumper has to be fitted, or both.

Axial polystyrene caps require care in determining where to bend the legs. Their size is not standardized and subject to various tolerances compared to other parts.

Finally, on the potentiometers, plastic types from Vishay Spectrol may be used instead of cermet. At the time of writing, supply of the

cermet versions was subject to a lead time of up to 93 working days at Farnell's. Next month's installment will discuss the very high quality MC/MM preamplifier board.

(110650)

References

- [1] Precision Preamplifier 96, by Douglas Self. *Wireless World* July/August & September 1996.
- [2] The 5532 OpAmp, by Douglas Self. *Elektor* October & November 2010, www.elektor.com/100124 and www.elektor.com/100549.



ARE YOU READY FOR THE **X-CHIP FACTOR?**

INTRODUCING THE **X-CHIP** USB BRIDGE FAMILY



EXtensive Interface Selection
UART, FIFO, SPI, I2C, FT1248

EXtended Temperature Range



Battery Charger Dete**X**ion



EXpandable Clocking
INTERNAL CLOCK GENERATION
EXTERNAL CLOCK OUT



EXceptional Support



Additional features:

- ✓ Royalty free, validated USB driver support
Windows, Android, Linux & Mac OS
- ✓ Low active power: 8mA
- ✓ Internal MTP memory for flexibility
- ✓ Integrated 3.3V level converter

us.sales@ftdichip.com
www.ftdichip.com



RS-485 Switch Board

ElektorBus relay module

By Jens Nickel

Our ElektorBus series has shown how much interest there is in home automation applications. Here we describe a small circuit board that can switch two AC (230 VAC) loads. Also, two of the inputs to the on-board microcontroller are brought out to terminals so that the state of two switches can be read back. The board works with the ElektorBus and so is an ideal building-block for a home automation system controlled from a PC, tablet or smartphone.

So far the ElektorBus project has centered around hardware and software for experimental and development purposes. We will now start to move towards a more finished system, in particular looking at home automation applications, which have generated a lot of interest among our readers. The board we describe here is designed to switch two AC (230 V) loads and to read the state of two switches. The module is compact and based on an ATmega88 and an LT1785 RS-485 driver, the same ICs as we used in the ElektorBus experimental node [1]. Demonstration software that talks the ElektorBus protocol is also available for download, to run on microcontrollers, PCs and smartphones. The relay module, which is available ready-built from Elektor, can of course also be used in other projects.

Bus connection

The circuit diagram is shown in **Figure 1**. The circuit receives its 12 V DC power supply over screw terminal connector K3. The RS-485 part of the circuit closely mirrors that of the experimental node, with data lines RO and DI, control lines DE and /RE, which allow half-duplex operation, and the RS-485 bus signals A and B. A 120 Ω termination resistor can optionally be wired across the bus lines using a jumper. The four wires of the ElektorBus are connected at K3: 12 V and GND to supply power and the A and B data lines. Besides those there are two extra connections. The first, 'Shield', is intended to be connected to

the cable's screen. This is connected to ground via jumper JP1: this should normally be done only on one node, for example the one that provides power to the bus. The second extra connection, 'SIG_GND' (for 'signal ground') provides an additional connection to the ground point of the RS-485 driver. For the moment this signal is simply connected to bus ground in the relay module. However, we wanted to allow for the future possibility of providing a separate ground for the RS-485 driver IC. When loads are switched it is possible that there will be local interference generated on the bus ground; and if the ground potentials at the drivers differ too widely this can result in spurious bits being detected on the bus. We have already observed this effect once [2]. One solution might be to connect signal ground directly to bus ground at only one point on the bus, while in the other bus nodes the two signals are linked via (for example) a 100 Ω resistor. Of course, this arrangement requires a fifth conductor in the bus cable. We have not yet tested this possibility, but keep the option open for when the bus is a little more mature: by all means experiment yourself!

Microcontroller pins

The test LED, test button, ISP (in-system programming) interface and clock and power supply circuitry will all be familiar from the experimental node design. We have replaced the single-in-line expansion

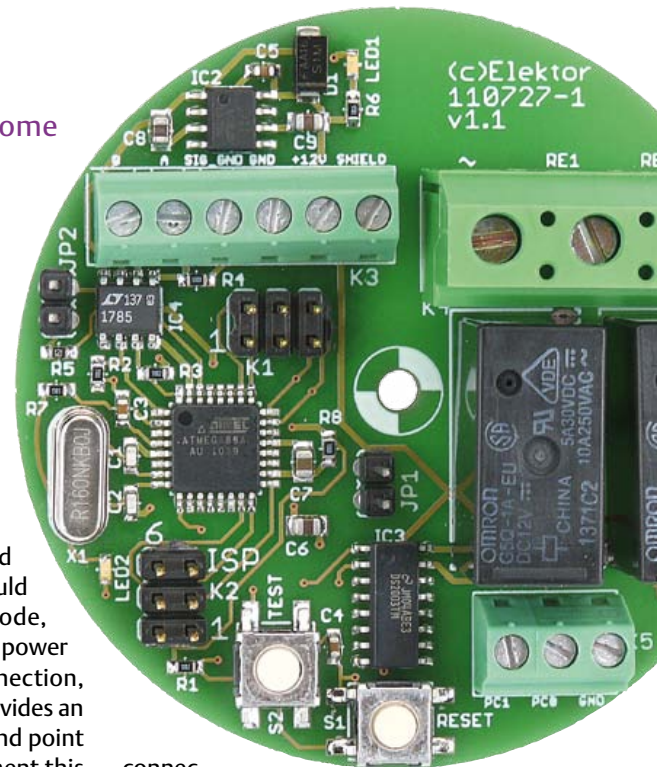

connector with a 2-by-3 header, which is more compact and for which it is easier to find suitable cables. The connector gives access to four of the microcontroller's pins, each of which can be used as a digital input or output or as an analog input (ADC0 to ADC3). Two of these pins, along with ground, are also brought out to screw terminals, making it easy, for example, to connect a light switch. **It should go without saying that the switch and all associated cables should be kept well away from any AC powerline wiring!**

The main feature of the module is the pair of relay-switched outputs. These are connected to two of the microcontroller's pins, PB0 and PB1, via relay driver IC3. The relays are SPST NO (single pole, single throw, normally open) types. With the circuit as shown these switch between the input labeled 'phase' and the outputs labeled 'S1' and 'S2'. These three signals are brought to larger screw terminals. The relay outputs can be used to switch low-voltage equipment or mains equipment such as lighting. If AC powerline voltages are used, the module must be mounted in an enclosure that

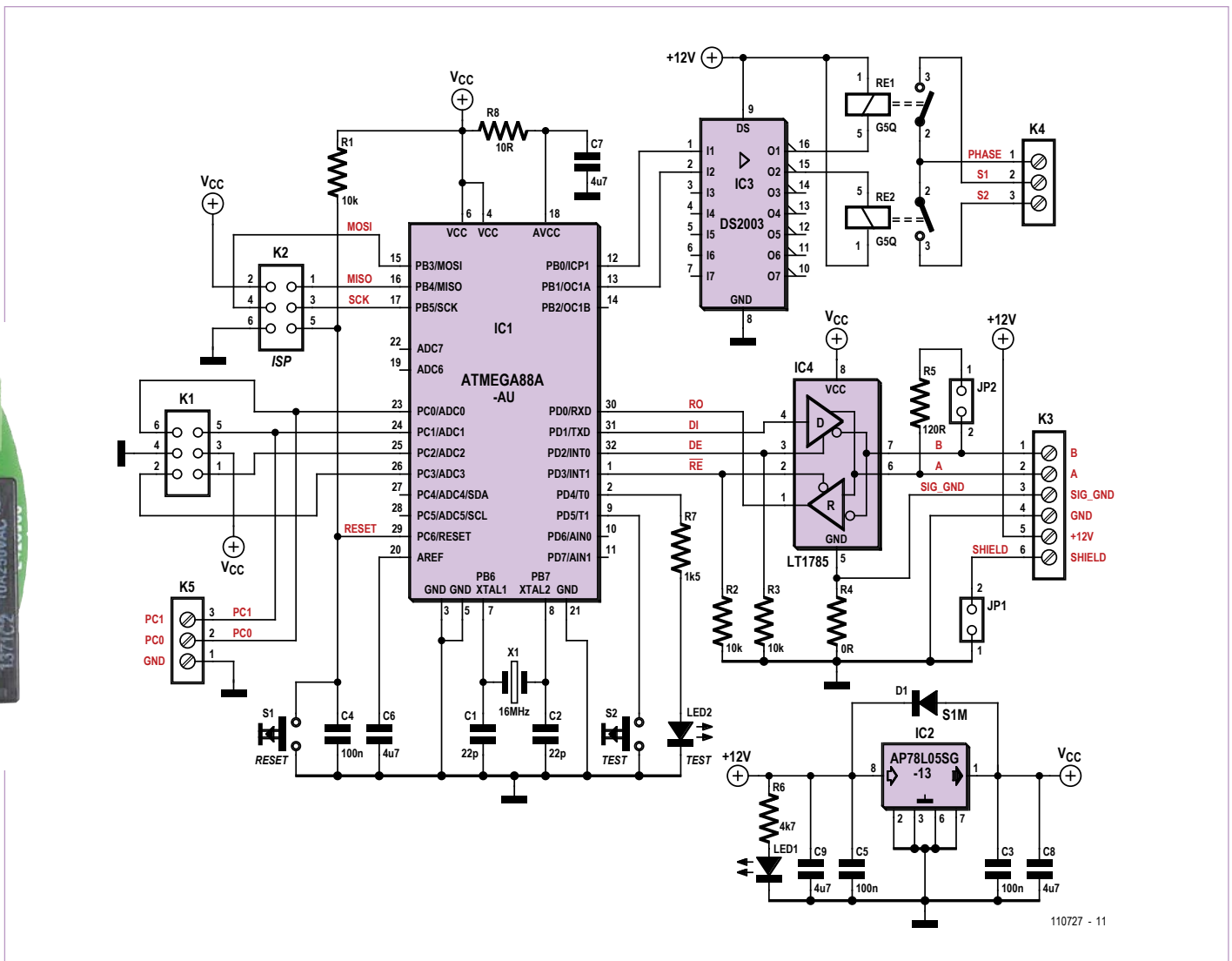

Figure 1. Up to two loads and two switches can be connected to the module using the screw terminals.

prevents accidental finger contact in accordance with all applicable regulations in your state or country.

The printed circuit board is round and compact, and can be fitted into an enclosure with a diameter of 60 mm (Figure 2). Do **not** fit the board in a junction box that already carries domestic AC grid wiring, and the bus wires should not be run parallel to AC wiring in trunking (see also the 'Cabling' text box). The switching module should be fitted in its own enclosure and the bus cable in its own trunking. In many countries electrical installations such as this must only be

carried out by suitably qualified or competent people.

Software

With suitable firmware we can breathe life into the switching module. The ready-built modules are delivered with the microcontroller not programmed, as the board can be used for a wide range of applications. However, there is of course demonstration software available, which is compatible with the ElektorBus. The relays can be switched from a PC, using our USB-to-RS-485 converter and the ElektorBusBrowser.exe

software. The same can be done from an Android smartphone or tablet, using the combination of the AndroPod board and the free ElektorBusBrowserForAndroPod app described recently [3], [4]. We also provide a suitable user interface to allow the relays to be controlled. This is implemented in HTML and works equally well on PCs and Android devices.

The hardware is wired up as shown in Figure 3. As usual, the software is all available for free download from the project web page accompanying this article [5], and source code is of course provided.

Elektor Products and Support

- RS-485 switch board (ready built and tested): # 110727-91
- USB-to-RS-485 Converter (ready built and tested): # 110258-91

- Free software download

All products and downloads are available via the web pages accompanying this article: www.elektor.com/110727

COMPONENT LIST

Resistors

SMD shape 0603
 R1,R2,R3 = 10kΩ
 R4 = 0Ω
 R5 = 120Ω
 R6 = 4.7kΩ
 R7 = 1.5kΩ
 R8 = 10Ω

Capacitors

C1,C2 = 22pF NPO (0603)
 C3,C4,C5 = 100nF X5R (0603)
 C6,C7,C8 = 4.7μF X5R 10V (0805)
 C9 = 4.7μF X5R 25V (0805)

Semiconductors

D1 = S1M (1000V / 1A)
 LED1,LED2 = LED, green (0603)
 IC1 = ATmega88A-AU, programmed
 IC2 = AP78L05SG-13
 IC3 = DS2003TM/NOPB
 IC4 = LT1785CS8#PBF

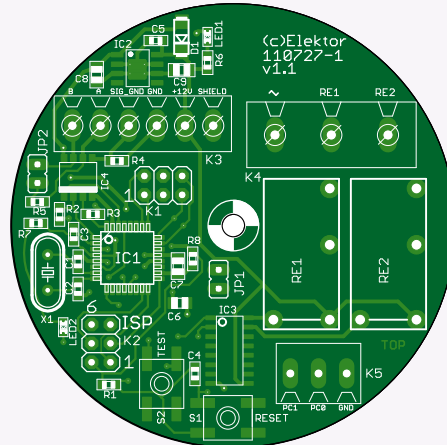

Figure 2. To keep the board compact we have used SMD components. The circular shape allows installation in an enclosure with a diameter of 60 mm.

Miscellaneous

RE1,RE2 = 12V, SPST-NO (e.g. G5Q-1A-EU DC12)
 JP1,JP2 = 2-pin pinheader, lead pitch 0.1 in. (2.54mm)
 K1,K2 = 6-pin pinheader, lead pitch 0.1 in. (2.54mm)
 K3 = 6-way screw terminal block, lead pitch 3.81mm
 K4 = 3-way screw terminal block, lead pitch 7.62mm
 K5 = 3-way screw terminal block, lead pitch 3.81mm
 X1 = 16MHz quartz crystal, HC-49S case
 S1,S2 = pushbutton, SPNO (e.g. B3S-1000)
 PCB # 110727-1

alternatively

Ready assembled and tested board # 110727-91

After opening the zip archive the first thing to do is drag the 'UIBus' folder to the desktop. Then, if you will be using a smartphone as a controller, transfer the required files to it, for example using the PC software Adif-Controller as described in [4]. The firmware needs to be programmed into the microcontroller: the firmware is written in C using the 'AVR Studio' environment, and a ready-compiled hex file is included in the download. In this example the data EEPROM in the ATmega88 is not used: the board's node address (which is '5') is hard-coded into the program.

Testing

After firing up the ElektorBusBrowser the HTML user interface will appear: see **Figure 4**. In the PC version the COM port address must be set up first using the combo box at the top of the screen, matching the address used by the USB-to-RS-485 converter. Then click on the button below. The ElektorBus scheduler can now be launched by clicking the 'on' button in the

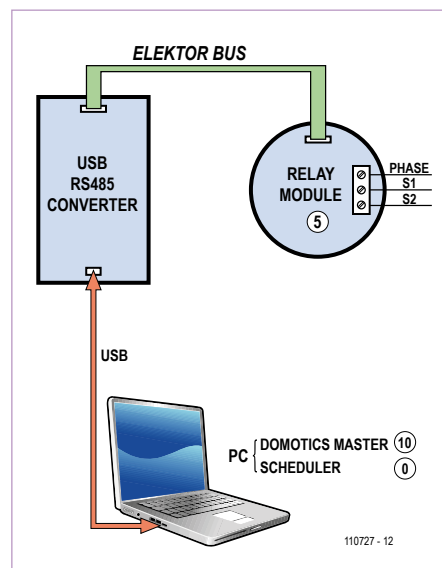

Figure 3. For a first test connect a USB-to-RS-485 converter and a relay module together over the bus. The relay module has node address 5 (hard-coded into the demonstration firmware).

HTML user interface. The scheduler now polls the master (with node address 10) at regular intervals to prompt it to send any switching command that might be available to the relay module. It is of course necessary to arrange for the command to be acknowledged: when the relay module receives a command, it replies with a message that contains the current state of its two relays. This means that the module is never directly addressed by the scheduler. As a consequence it is possible to have over a hundred relay modules connected to a single bus without the congestion that would arise from having the scheduler poll them all. In fact, the status message is sent during the so-called 'FreeBusPhase' which is initiated by the scheduler after each occasion when the master is polled. During a Free-BusPhase any bus participant that happens to have something to say is free to send a message. A collision can occur if there is more than one such participant, and so, if safe receipt is important, the acknowledge message from the relay module must in

Cabling

As we reported in the 'E-Labs Inside' section of the March 2012 edition, we have been testing various cables for use with the bus. You can see the results in a YouTube video [7].

We started with a ten-core cable from the store room, which had one pair twisted. Next we tested some CAT 5e cable (four twisted pairs with an overall screen). We found cable lengths of 30 m caused no problems at all in either case, and so it seems that we do not need to recommend a specific cable. The only important aspect

is that the A and B signals should be carried on a twisted pair.

It is not normally allowed for the network cable to be carried in the same conduit as 115V powerline wiring. In some countries exceptions are made for special-purpose cables, of which one example is the YCYM 2x2x0.8 EIB/KNX bus cable designed for home automation applications. It should be possible to use such a cable with the ElektorBus, but we have not tested it. Such cable is somewhat pricey: it can cost several pounds per meter.

turn be acknowledged by the PC. This Free-BusPhase 'AcknowledgeMessage' is automatically sent by the JSBus Javascript library that is loaded as part of the demonstration HTML file (see Listing). The library decodes the message from the relay node, and the user application code simply has to accept the two 'parts' (information units) which comprise the message. The first part represents the status of relay 1 (sent on channel 0) and the second part the status of relay 2 (on channel 1 within the same message). The function `ProcessPart`, which is defined in the Javascript code in the HTML page, is called for each of the two parts. Within this function the status value (zero for 'off' or one for 'on') is used to update the status text suitably for the appropriate relay

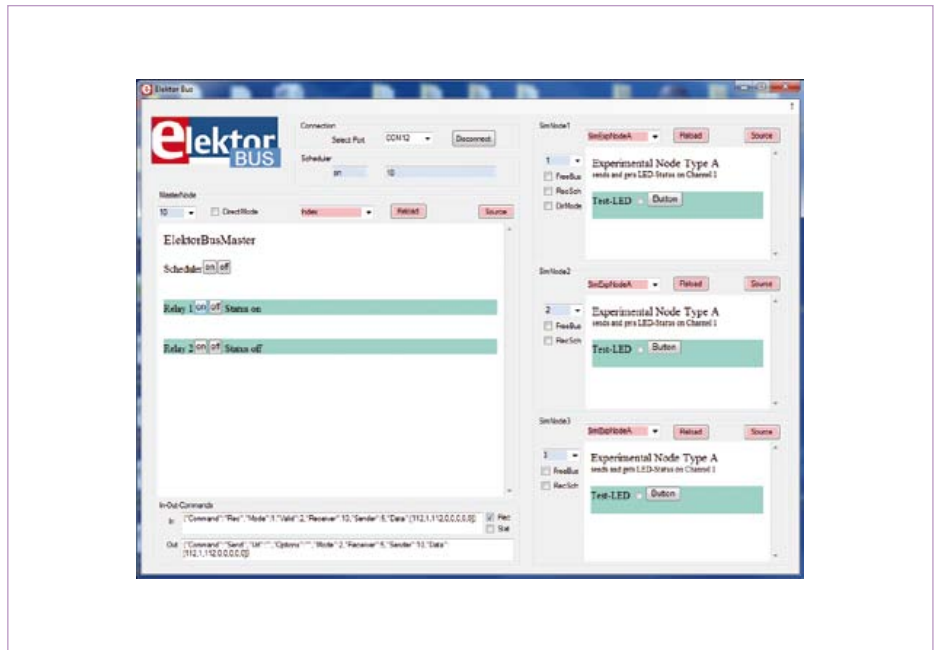

Figure 4. The ElektorBusBrowser PC software and the HTML user interface (left). In the window to the right you can see simulated bus nodes which can be brought into action for development purposes [8].

Advertisement



AP CIRCUITS

PCB Fabrication Since 1984

As low as...

\$9.95

each!

Two Boards
Two Layers
Two Masks
One Legend

Unmasked boards ship next day!

www.apcircuits.com







FlashPro430

FlashPro-CC

FlashPro2000

GangPro430

GangPro-CC



USB Flash Programmers for Texas Instruments' MCUs
MSP430, Chipcon CCxx, C2000 DSPs

Reliable and the fastest programmer on the market.
Perfect for production usage.

- * can assign unique serial number
- * up to eight programmers can be connected to one PC and program target devices simultaneously



One PC and 8 programmers



www.elprotroic.com

Listing: User interface in HTML and Javascript (excerpt)

```
<SCRIPT src='JSBus.txt' Language='javascript' ></SCRIPT>
<SCRIPT Language='javascript' >

function ProcessPart(part)
{
  if (part != null)
  {
    if(part.Sender == 5)
    {
      if(part.Channel == 0)
      {
        if (part.Numvalue == 0) {TextSetvalue ("StatusRelay1","off");}
        if (part.Numvalue == 1) {TextSetvalue ("StatusRelay1","on");}
      }

      if(part.Channel == 1)
      {
        if (part.Numvalue == 0) {TextSetvalue ("StatusRelay2","off");}
        if (part.Numvalue == 1) {TextSetvalue ("StatusRelay2","on");}
      }
    }
  }
}

function SwitchRelay1(Status)
{
  var parts = InitParts();
  parts = SetValue(parts, 10, 5, 0, 0, Status);
  SendParts(parts, true);
}

function SwitchRelay2(Status)
{
  var parts = InitParts();
  parts = SetValue(parts, 10, 5, 1, 0, Status);
  SendParts(parts, true);
}

</SCRIPT>
...
```

in the HTML user interface. We have covered the above more thoroughly in previous articles on the Elektor-Bus. However, from now on it won't be necessary to look back at those articles to check some detail: information about the message protocol, application protocol and

the rapid development system built around HTML and Javascript can be found in the new ElektorBus Reference document, which is available for free download at [6].

What the future holds

Switching equipment on and off using a PC or smartphone is a neat application, but it would be even better if everything could be operated remotely, even from the other side of the world. In the near future we will look at how this can be achieved: in the pipeline we have an expanded microcontroller board that includes not only an RS-485 interface (of course!) but also a socket for mounting a network interface module. This will let us use the communication facilities of smartphones and tablets to the full in conjunction with the ElektorBus. And the final destination of our bus? You will have to wait and see!

(110727)

Internet Links

- [1] www.elektor.com/110258
- [2] www.elektor.com/110225
- [3] www.elektor.com/110405
- [4] www.elektor.com/120097
- [5] www.elektor.com/110727
- [6] www.elektor.com/elektorbus
- [7] www.youtube.com/watch?v=rbDSTXNARmw
- [8] www.elektor.com/110708

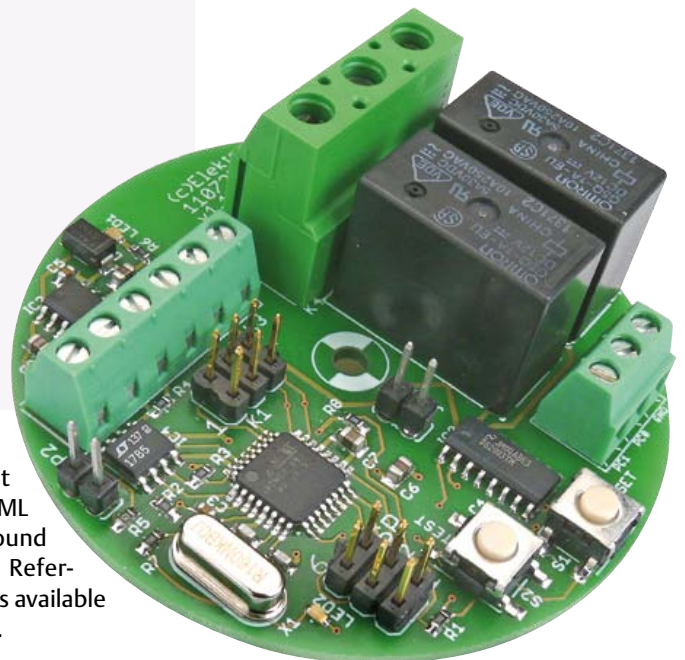

RL78 GREEN ENERGY CHALLENGE

Competition starts March 26

The RL78 Green Energy Challenge

Renesas has partnered with IAR Systems to deliver engineers a power-house combo of low-power devices and high-quality software. They're steering a great, green revolution and are challenging you to transform how the world experiences energy efficiency by developing a unique, low-power application using the RL78 MCU and IAR toolchain. Succeed and win a share of \$20,000 in cash prizes!

The competition starts March 26, 2012 and ends on August 31, 2012. Winners will be announced in October at Renesas' DevCon 2012.

Hundreds of free RL78/G13 development kits, loaded with IAR's Kickstart edition, are being distributed to those who qualify. Quantities are limited so don't delay! Be the green you see in the world and get ready for the RL78 Green Energy Challenge.

Official Contest Partners: Analog Devices, Inc., CMX Systems, Inc., Exosite, GainSpan Corporation, IAR Systems, Micrium, NDK Crystals (Nihon Dempa Kogyo Co., Ltd.), Okaya Electric Industries Co. Ltd., and Total Phase, Inc.

\$20,000 in cash prizes...

...and additional weekly drawings



In association with *Elektor* and *Circuit Cellar*

For complete details, visit

www.circuitcellar.com/RenesasRL78Challenge



Earn additional prizes like development tools, Pmods, Wi-Fi modules, embedded systems books, and more from contest partners through weekly prize drawings. **Follow Renesas on Twitter and Facebook for contest updates. @RenesasAmerica**

LED Touch Panel

Shine and touch

Design: Thomas Pototschnig (Germany) Text: Luc Lemmens (Elektor Labs)

A touch panel can be made in several different ways. Although the method described here has been known about for a substantial number of years, it is rarely used in practice. Despite this, it is very interesting and it's certainly worth experimenting with. The theory: Two IR LEDs transmit light. When a finger is above them the light will be reflected off it, which can then be detected by a third IR LED that has been configured as a detector at that point in time.

Touch sensitive switches have been reliable replacements for mechanical switches for many years. They also provide a much smoother way to control a device. They are much less prone to wear and they can, depending on the technology used, often be used in conditions where their mechanical counterparts would fail.

Several methods are used to detect a key-press or a position on a touch panel, which often involves a detection of the change in resistance or capacitance. In this project a completely different method is used. Here we make use of the reflection and detection of (infrared) light to determine where a panel is touched. The panel itself consists of a matrix of eight by eight IR LEDs, where use is made of a little known property of LEDs: they can detect light as well as emit light. An LED that has light shining on it with preferably the same wavelength will produce a small voltage as long as it's not heavily loaded. Simply put, the method used here uses three LEDs at a time. The circuit lights up the outer two LEDs and the middle LED is used to 'see' if any of the light is reflected (**Figure 1**). When the matrix is scanned continuously, it is possible to determine where the panel is touched. The panel sends the information via the USB link to a PC where a program calculates the touch position and displays it on a square window of 8 by 8

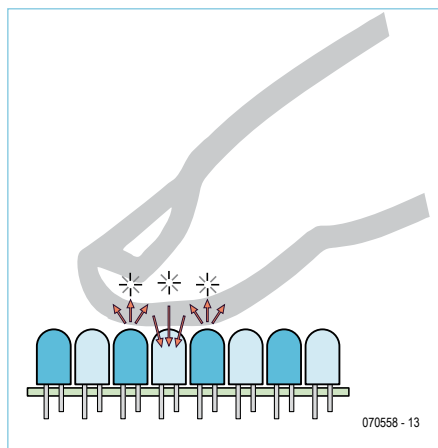
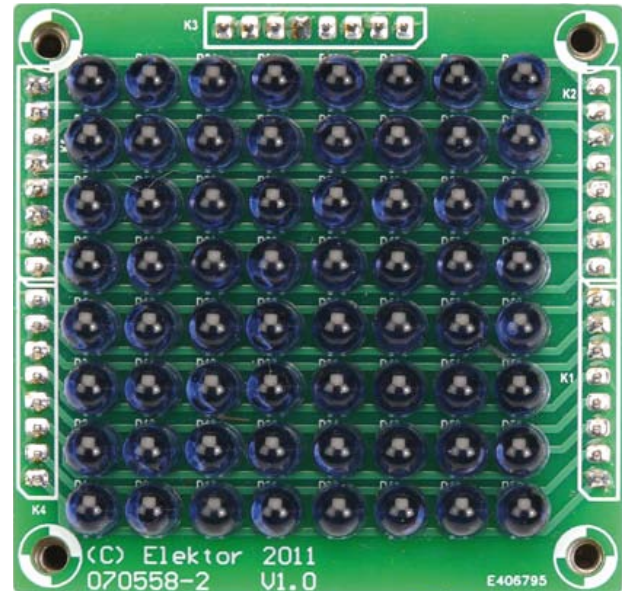

Figure 1. The theory: Two LEDs emit IR light, which is reflected by the finger and then detected by the LED in the middle.

blocks. The resolution is therefore quite limited and the PC application is used more to illustrate the principles involved rather than to have a practical purpose. It does, however, lend itself to experimentation, since both the firmware and the C++ application for the PC have their source code available for free on our website [1].

Circuit diagram

Figure 2 shows the circuit diagram of the LED section. In here you can see that what



was previously described as an 8 x 8 matrix is in reality made up of two matrices of four by eight LEDs (**Figure 3**). The even columns belong to one matrix and the odd ones to the other. This makes it possible to make LEDs in certain columns transmit, whilst those in the neighboring column are used to detect how much of the light is reflected. At the heart of the circuit in **Figure 4** is IC3, an ARM7 microcontroller made by Atmel. This includes a USB interface, which is used during the programming of the firmware for the circuit and also to send scanning information to the outside world, in this case the program that's running on the PC. The connections labeled COLx and ROWy control the drivers for the columns and rows of the LED matrices. Another five port pins are used to control the analog multiplexer (IC4) and an analog input on AD4 measures the voltage that comes from a single selected LED in the panel.

Between the analog multiplexer and the A/D input of the microcontroller is a band-pass filter with a center frequency of 10 kHz. When the LEDs function as transmitters they are driven with a pulsed signal with a frequency of 10 kHz in order to differentiate and suppress potentially interfering light sources. An extra 'filtering' of the background light takes place in the software: Immediately after turning on the

touch panel the first ten scans are used to determine the ‘black’ value of each pixel; it is therefore vital to leave the touch panel unobstructed during this phase.

The scanning starts in the top-left corner of the panel. The LEDs in the first and third column of the first row are turned on via drivers IC5 to IC7. At the same time the LED in the second column is connected to AD4 of IC3 (the input to an A/D converter in the microcontroller) via the analog multiplexer (IC4) and the bandpass filter around IC2B. When the LEDs in the outermost columns are scanned there will only be a single LED lit in the previous column, since there is no other ‘neighbor’. The information from all pixels is sent via the USB link to the PC, where the analysis and the display of information take place.

Construction

Elektor Labs have designed two board layouts for this project: one for the LEDs and one for the control of the touch panel (Figures 5 and 6). These can be mounted on top of each other, with the LEDs on top. We would recommend that you first solder the ARM7 processor (IC3), which is by far the most difficult part in this project with its 64-pin LQFP package. It won’t do any harm to wait with mounting the driver ICs, the filter and the analog multiplexer. Instead, you should first test the USB connection between the PC and touch panel (see the text below) before you fully populate the PCB. This makes any subsequent fault finding much easier should you need to carry it out. During the test phase of the circuit and whilst modifying the firmware for the processor it’s easier if you mount a (temporary) switch on JP1.

Programming the ARM processor

To make the touch panel work, the ARM processor first has to be provided with the correct firmware. From Atmel’s website you can download a program called SAM-BA [2], which is a PC application that lets you program the flash memory of the touch panel. You should install this program on your PC. As part of the download on our website for this project [1] you will also find the source code for the firmware for the

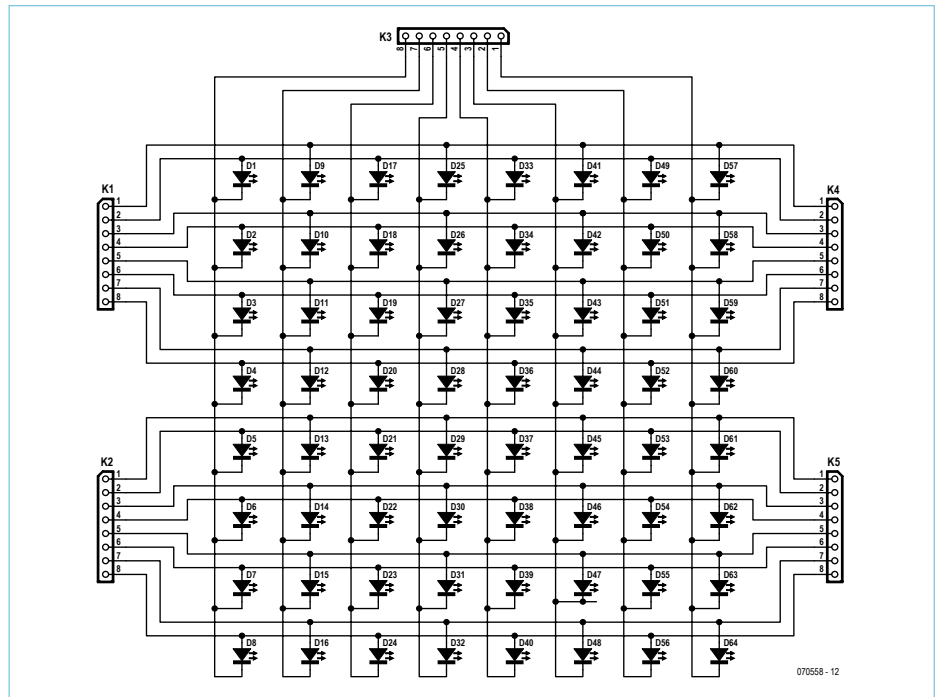

Figure 2. The LED section consists of a matrix of 8 x 8 IR LEDs, divided into two groups of 4 x 8 LEDs.

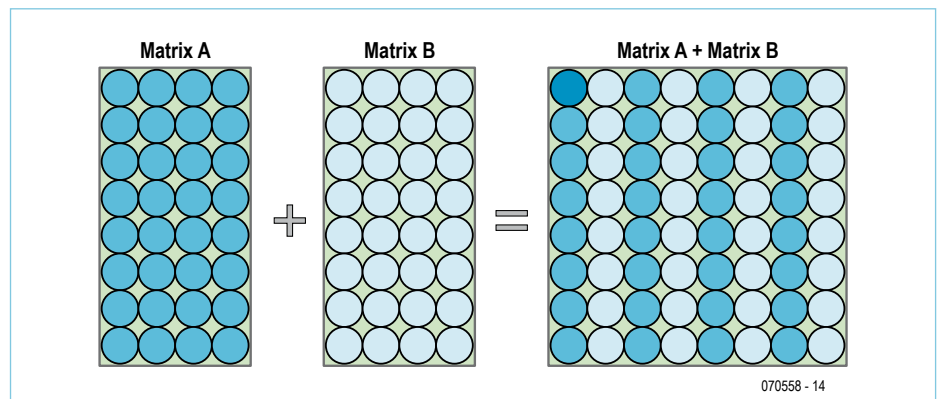

Figure 3. This is how the two LED groups are wired up. In this way two LEDs can always be driven with the LED in between being used as a sensor.

AT91SAM7S256, developed using WinARM. Before you connect the supply voltage (i.e. connect the USB cable) you should put a jumper across JP1 of the touch panel. Once the power is connected you should wait a minimum of 10 seconds. The processor will then load SAM-BA Boot in the first sectors of its flash memory. This is the boot program that, amongst other things, makes it possible to program the ARM via the USB port. This so-called Boot Recovery Procedure is carried out automatically when the TST, PA0, PA1 and PA2 pins are all high during the start-up. The jumper sets the TST level; the other port pins are all held high by pull-up resistors (R3 to R5).

After 10 seconds you should disconnect the USB cable, remove jumper JP1 and then reconnect the circuit to the PC again using the USB cable. Windows will then detect a new device and should install its associated driver. If for some reason this driver isn’t found automatically, you should manually select the folder ‘DRV’ in the Atmel SAM-BA folder. When the installation of the driver has finished, you should see the window shown in Figure 7.

Next, start SAM-BA on the PC. If necessary, select the required virtual COM port for the USB connection and the target board as shown in the screen-dump in Figure 8.

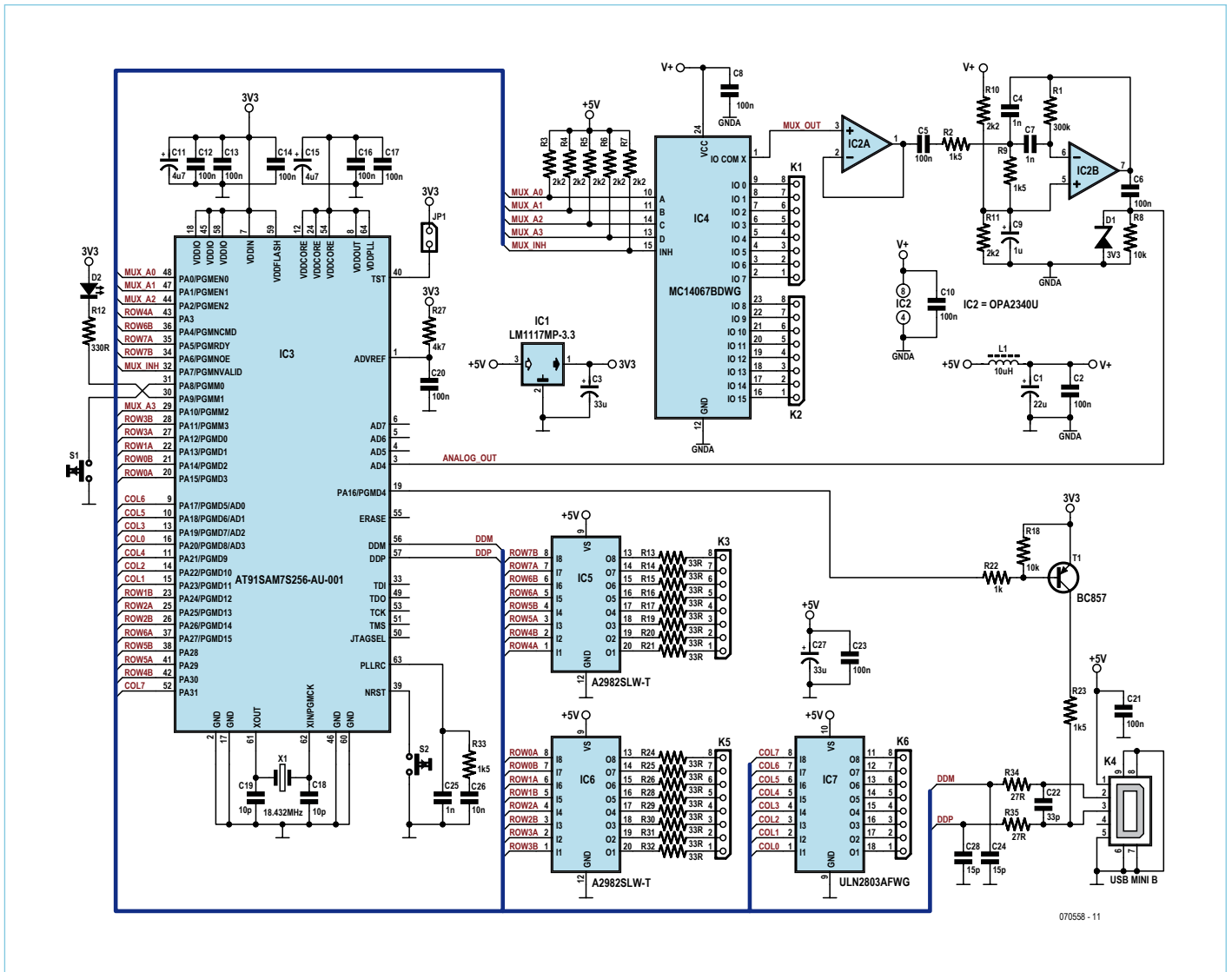

Figure 4. The circuit diagram for the touch panel is fairly straightforward. Most of the hard work is done in software.

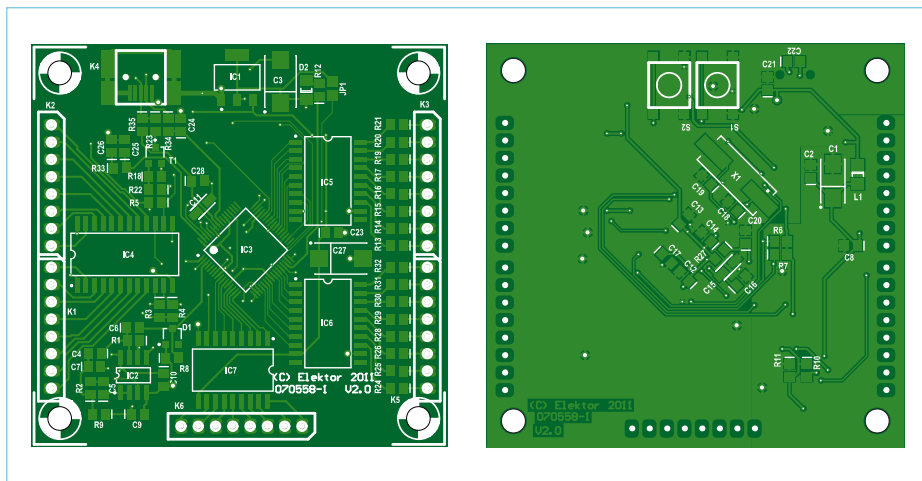

Figure 5. The PCB for the electronics from Figure 2 (90% of real size).

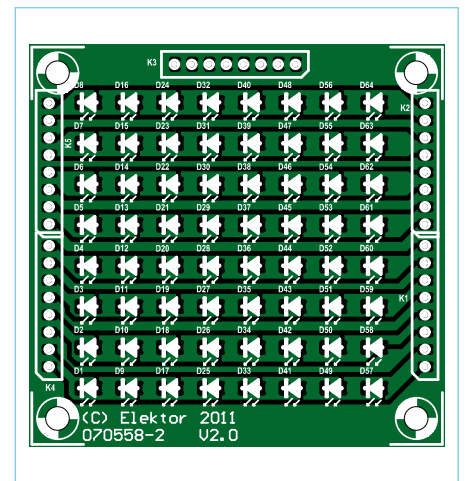

Figure 6. This PCB is home to the 64 IR LEDs (90% of real size).

COMPONENT LIST

Controller Board

Resistors

(all SMD 0805)

R1 = 300k Ω

R2,R9,R23,R33 = 1.5k Ω

R3–R7,R10,R11 = 2.2k Ω

R8,R18 = 10k Ω

R12 = 330 Ω

R13–R17,R19,R20,R21,R24,R25,R26,R28–R32 = 33 Ω

R22 = 1k Ω

R27 = 4.7k Ω

R34,R35 = 27 Ω

Capacitors

C1 = 22 μ F 6.3V tantalum (Kemet shape C)

C2,C5,C6,C8,C10,C12,C13,C14,C16,C17,C20,C21,C23 = 100nF (SMD 0805)

C3,C27 = 33 μ F 16V tantalum (Kemet shape D)

C4,C7,C25 = 1nF (SMD 0805)

C9 = 1 μ F 16V (XR7 SMD 0805)

C11,C15 = 4.7 μ F 10V tantalum (Kemet shape A)

C18,C19 = 10pF (SMD 0805)

C22 = 33pF (SMD 0805)

C26 = 10nF (SMD 0805)

C24,C28 = 15pF (SMD 0805)

Inductors

L1 = 10 μ H 760mA (Taiyo Yuden CBC3224T100MR)

Halfgeleiders:

D1 = 3.3V 0.25W zener diode (SOT23)

D2 = LED, red, 25mA (SMD 1206)

T1 = BC857C (SOT23)

IC1 = LM1117MP-3.3 (SOT223)

IC2 = OPA2340UA (SO8)

IC3 = AT91SAM7S256-AU-001, programmed

IC4 = HCF4067 (SO24)

IC5,IC6 = A2982SLW-T (SOIC20)

IC7 = ULN2803AFWG (SOIC18)

Miscellaneous

X1 = 18.432000MHz quartz crystal, HC49/4H_SMX

S1,S2 = SMD pushbutton, 6.5x6.5mm (e.g. Panasonic EVQQQ2503W)

K1,K2,K3,K5,K6 = 8-way pinheader receptacle, lead pitch 2.54mm

K4 = Mini-USB-B chassis socket SMD (e.g. Molex 675031020)

PCB # 070588-1 [1]

LED Board

D1–D64 = IR LED, 5 mm (e.g. Vishay TSUS5202)

K1–K4,K6 = 8-pin pinheader, lead pitch 2.54mm

PCB # 070588-2 [1]

If everything went well you should see a window similar to that in **Figure 9**. If this isn't the case, you should check in Windows Device Manager that the driver has been

installed correctly and that all the settings for SAM-BA just mentioned were correctly configured at the start.

From the 'Download/Upload File' section

you should select 'Send File Name' and browse for the file 'Main.bin' that is part of the download from our website. Click on the button 'Send File' to program the firm-

Advertisement

Propeller Board Of Education

Complete Multicore Setup — The Propeller Board Of Education includes a full set of peripherals that can support an amazing array of projects. **Features include:** P8X32A microcontroller, 64 KB EEPROM, 5 MHz crystal; XBee wireless transceiver socket; SD Card socket for data logging, extra program storage, etc.; Microphone audio input and amplifier output; VGA port for visual feedback; (6) 3-pin servo/sensor ports; 10-bit A/D and D/A; Nearly 20 SMT LEDs for visual feedback; Voltage regulators provide up to 3 A @ 5 V, 360 mA @ 3.3 V; Power this board from USB, battery or wall supply.

Learn.parallax.com — Easy-to-follow web tutorials with beginner-friendly objects simplify Propeller programming for students and teachers who are new to the multicore environment. Just download the code and go!

Familiar Board Of Education Design — Based on the trusted design of the original BASIC Stamp Board Of Education used for learning microcontroller programming worldwide.

Volume Discounts — Great value with quantity price breaks. (10-pack; #32901)

Lifetime Warranty — Made in the USA. Parallax provides a limited Lifetime Warranty on craftsmanship.

Eight processors
Eight benefits!

\$129.00



PARALLAX

www.parallax.com

"ParallaxInc" on Twitter, Facebook, and YouTube



For more information: www.parallax.com/PropBOE

Order Propeller BOE (#32900) at www.parallax.com or call Sales toll-free 888-512-1024 (Mon - Fri, 8 AM - 5 PM, PDT)

Prices subject to change without notice. BASIC Stamp, and Board Of Education are registered trademarks of Parallax Inc. Propeller, Parallax, and the Parallax logo are trademarks of Parallax Inc.



Figure 7. ARM programming: Driver installation.



Figure 8. ARM programming: Selection of the correct COM port and target board when starting SAM-BA.

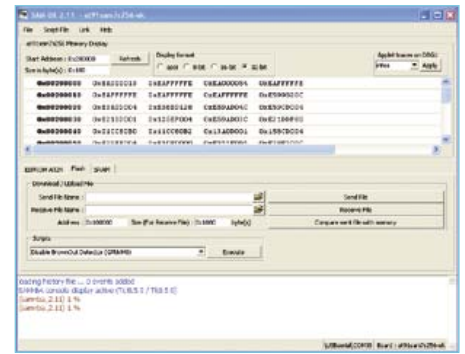

Figure 9. ARM programming: If everything went to plan SAM-BA shows this window.

ware in the flash memory of the processor. Exit from SAM-BA, disconnect the USB cable and reconnect it. Windows will then search for the driver, which is also part of our download (see **Figure 10**).

LED D2 will light up to indicate that the touch panel has been enumerated as a USB device. This LED will flash whenever the board communicates with the PC software. The touch panel is now ready to communicate with the 'Touchpanel' PC program.

Note that when you decide to experiment with the firmware we would recommend that you (temporarily) replace jumper JP1 with a switch. This is because the programming procedure described just now has to be repeated for each new version of the firmware. The installation of both drivers is the only part that has to be carried out once.

PC software

The display of a scan of the touch panel is produced in the PC. The program written for this shows a representation of the touch panel as 64 grayscale blocks with the most

likely touch position indicated by a red dot (**Figure 11**).

The software first filters the display

using a seventh order Gaussian FIR filter to suppress any interference. The calculation for the touch position is carried out on the basis of the 'center of gravity' of the image, a technique often used in digital image processing (see for example [3]). The source code was written in Visual Studio 2010 Express. A free version of this development environment can be downloaded from Microsoft's website [4].

And finally...

Although the touch panel is relatively small, the software and firmware provide many possibilities for adaptation and experimenting. This gives you the opportunity to create your own programs, which will take this project out of the experimental realm, such as games, a coded lock, or even a small version of Yamaha's Tenori-On.

(070558)

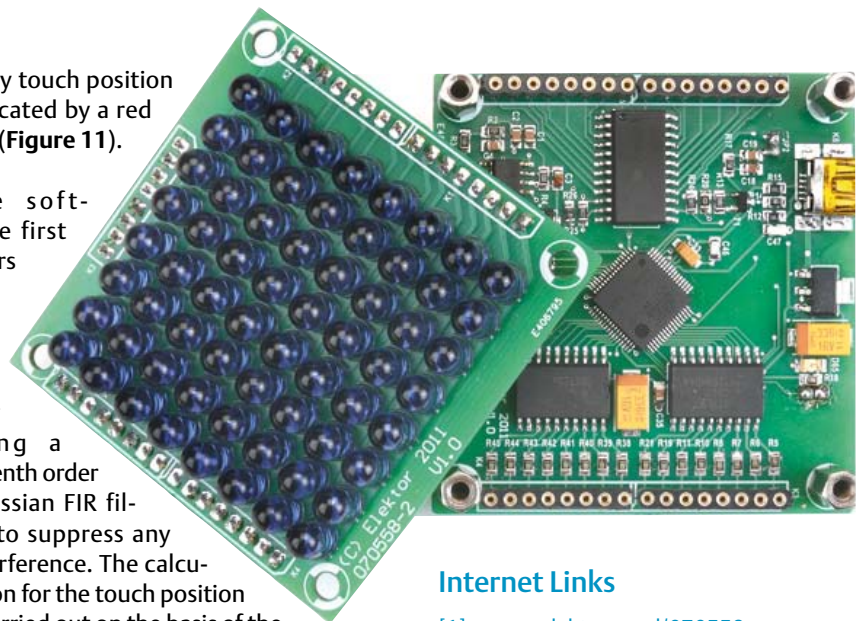

Internet Links

- [1] www.elektor.com/070558
- [2] www.atmel.com/tools/ATMELSAM-BAIN-SYSTEMPROGRAMMER.aspx
- [3] http://en.wikipedia.org/wiki/Image_moment
- [4] www.microsoft.com/visualstudio/en-us/products/2010-editions/express

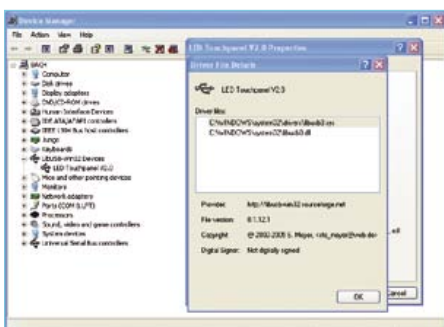

Figure 10. ARM programming: details of the touch panel driver files once they've been installed.

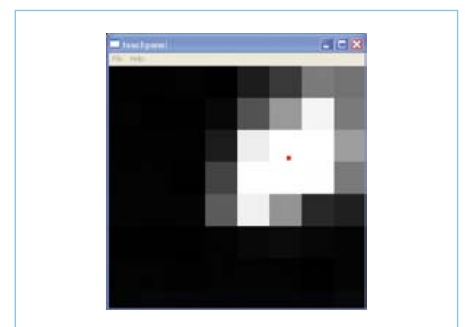

Figure 11. The red spot indicates where the LED matrix is 'touched'.

Fascinated by technology's impact on the future?

Check out Tech the Future!

Computing power and global interconnectivity are pushing tech innovation into overdrive. Pioneering technologies and creative workarounds affect even the couch potato 24/7. Tech the Future reports on technology strides that shape the future — yours included.

www.techthefuture.com

Follow Tech the Future

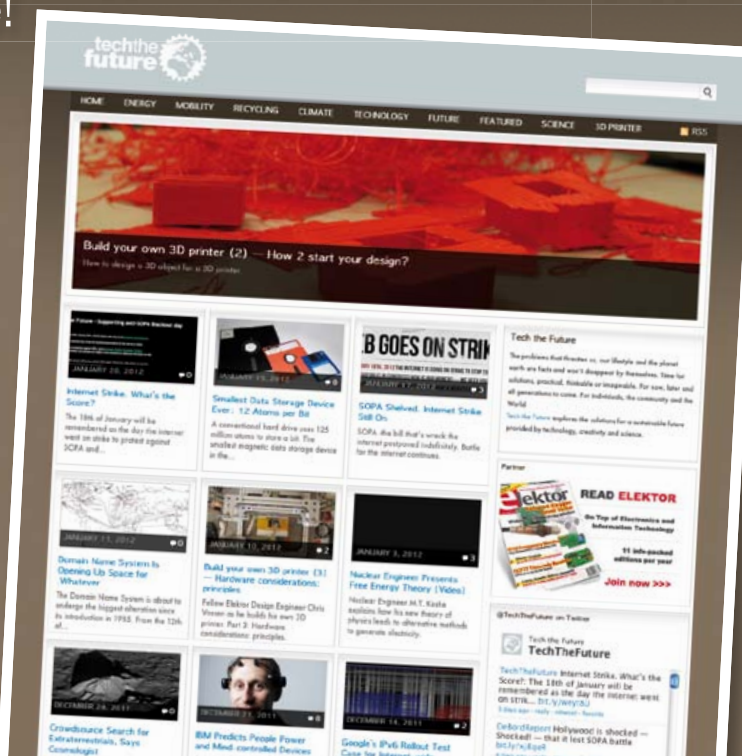

N E W N E S P R E S S

LEARN FROM THE EXPERTS!

Newnes Press has the resources you need to get started

SAVE 30% on all titles when you order from www.newnespress.com

Enter promotional code **Newnes30** at checkout.

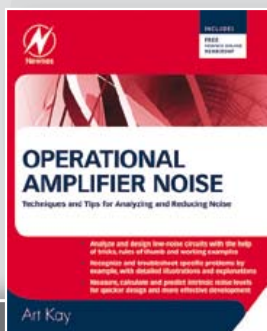

By Art Kay
ISBN: 9780750685252

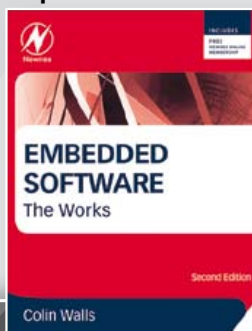

By Colin Walls
ISBN: 9780124158221



By Lucio Di Jasio
ISBN: 9781856178709

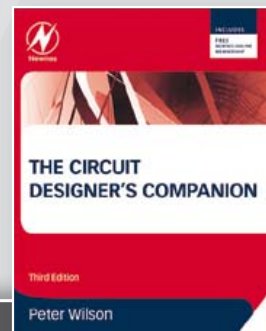

By Peter Wilson
ISBN: 9780080971384



Join our free membership page at www.newnespress.com

enews updates · Receive our best discounts · Hear about books before they publish

Access to free sample chapters, video tutorials and more!

*All books available as Print or ebook



Scan to access www.newnespress.com

Find us on Facebook!



Follow us on Twitter!

AVR Software Defined Radio (2)

Sampling signals

By Martin Ossmann (Germany)

As this series shows, the popular AVR microcontroller can be used for digital signal processing tasks. Here we will use an ATmega88 to sample amplitude- and phase-modulated signals which we can either synthesise ourselves or fish out of the ether. We can even operate at frequencies of above 100 kHz. How does it work? Read on to find out, in theory and in practice.



A carrier wave can be used to send audio or data through the ether by modulating it in amplitude, frequency or phase. In a ‘software defined radio’ the first thing that happens is that the received signal is sampled; then a processor carries out the necessary calculations to recover the modulating signal. In the case of data transmission, we then decode the signal into a stream of bits. To understand how this all works, we will first look at how an analog receiver operates.

Reception, the analog way

The input stage of many modern receivers looks like **Figure 1** (where we have not shown the first stage of ‘preselection’ filtering). It works as follows: suppose first that we want to receive a signal at U_{in}

with a frequency of $f_{RX} = 2$ kHz. We set the frequency f_{LO} of the local oscillator (or ‘LO’) also to $f_{LO} = 2$ kHz. In the upper branch of the circuit (which is called the ‘in-phase’ or ‘I’ channel) the input signal is multiplicatively mixed with the cosine wave produced by the LO. This produces a DC component X , which passes unchanged through the low-pass filter that follows. A component at 4 kHz is also produced, which is removed

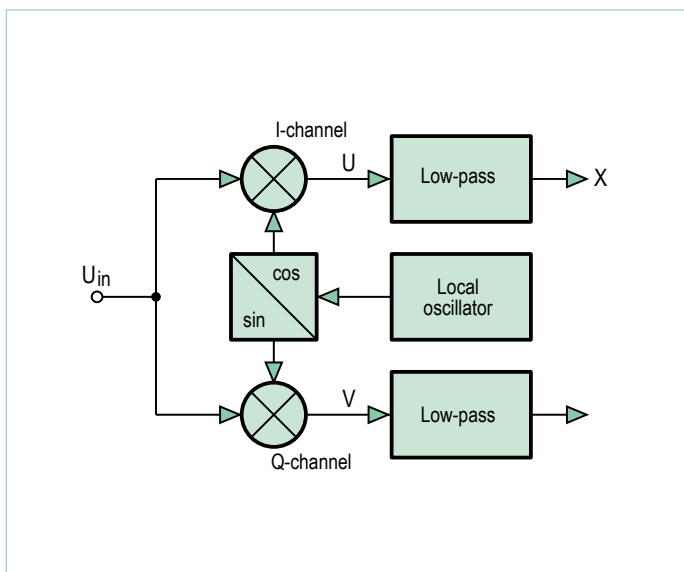

Figure 1. Quadrature mixing.

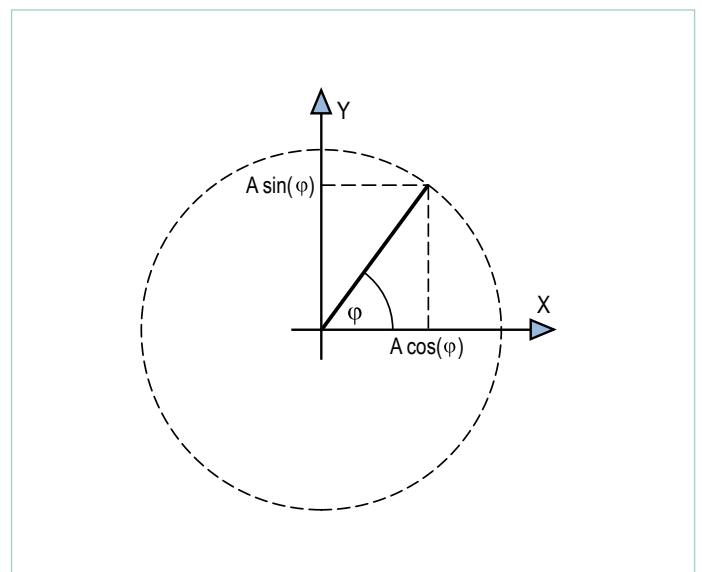

Figure 2. Geometrical interpretation.



by the low-pass filter. The value of X depends on the amplitude A and phase φ of the input signal, the phase being measured relative to the output of the local oscillator. More precisely, ignoring any gain in the low-pass filter, we have $X = A \cos \varphi$. If the input signal is exactly in phase with the cosine output of the local oscillator, X is maximized: this is why this branch is labeled 'in-phase'.

Much the same happens in the lower branch of the diagram. The difference is that the input is mixed with a sine signal (the cosine signal with a 90° phase shift). The value of Y depends again on the amplitude A and phase φ of the input signal, and we have $Y = A \sin \varphi$. Y is maximized when the input signal is 90° phase shifted with respect to the cosine output of the LO. For this reason, the lower branch is called the 'quadrature' channel.

Figure 2 shows the relationships graphically. The receiver can calculate the amplitude A and phase φ of the input signal from the values of X and Y .

Let's get digital

Now let's consider what happens when all the signals involved are sampled at a sample rate $f_s = 8 \text{ kHz}$, exactly four times the frequency of the input signal (see Figure 3).

The process of sampling converts the continuous-time input signal into a sequence of numbers. If the input signal U_{in} is a cosine wave with amplitude A and frequency 2 kHz (at the top of Figure 3), sampling generates the sequence of values $U_{in} = A, 0, -A, 0, A$ and so on. The values repeat every four samples, because we are sampling at four times the input frequency.

Let us look first at the in-phase channel and sample the cosine output signal of the local oscillator. The sequence of samples is $LO_{COS} = 1, 0, -1, 0, 1, \dots$. Again, this repeats every four samples. The mixer

multiplies the samples of U_{in} by those of LO_{COS} . The result is the sequence $U = A, 0, 0, A, \dots$. After the mixer this sequence is passed through a low-pass filter. We can construct a simple low-pass filter by calculating a rolling average of sequences of four consecutive samples of U . For simplicity we multiply this result by 2, and the output of the filter is then $X = A, A, A, A, \dots$; in other words, the output is a constant with value A . X can be thought of as samples of a DC level of A , where A is exactly the amplitude of the original input signal.

Now we turn to the quadrature branch. The inputs to this branch's mixer are the sequences $U_{in} = A, 0, -A, 0, A, \dots$ and $LO_{SIN} = 0, 1, 0, -1, 0, \dots$. The product of these sequences is $V = 0, 0, 0, 0, 0, \dots$; in other words, the constant value zero. The result of low-pass filtering V will also be zero.

The same argument can be applied when the input signal is a sine wave $U_{in} = A \sin(2\pi \cdot 2 \text{ kHz} \cdot t)$, giving the results $X = 0$ and $Y = A$. This shows that our discrete-time I-Q mixer works in just the same way as the classical analog I-Q mixer described above. We have also seen that if the sample rate is four times the signal frequency, the output signals of the LO only take on the values zero, plus one and minus one. This in turn means that the digital mixer does not need a multiplier: we simply need to add and subtract the relevant input samples in the low-pass filter to calculate the values of X and Y .

The hardware...

A simple front end circuit (Figure 4) was designed to test this idea on an AVR microcontroller. The analog-to-digital converter inside the ATmega88 is used to sample the input signal U_{in} and digitise it. The firmware then carries out the necessary calculations and the results, X and Y , are output using PWM on pins OC0A and OC0B. To

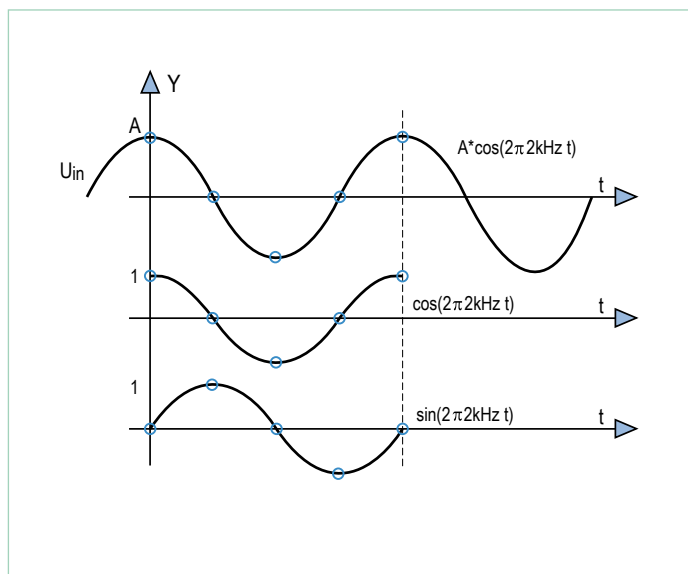

Figure 3. Sampling at four times the signal frequency.

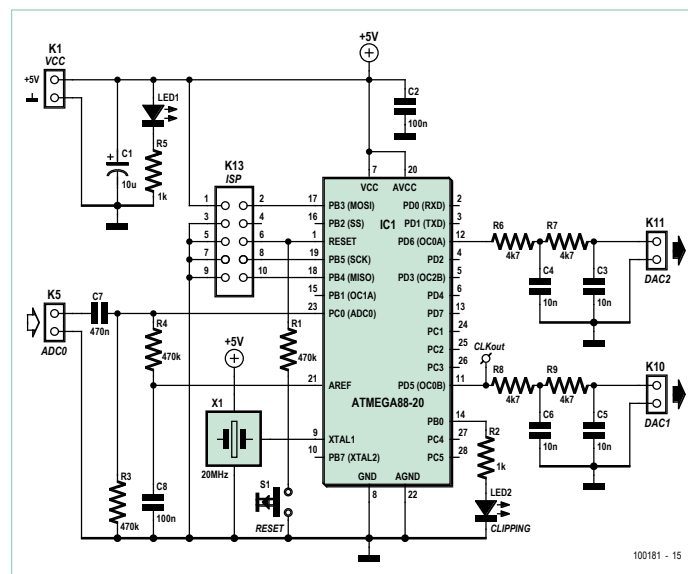

Figure 4. Hardware for a simple front end.

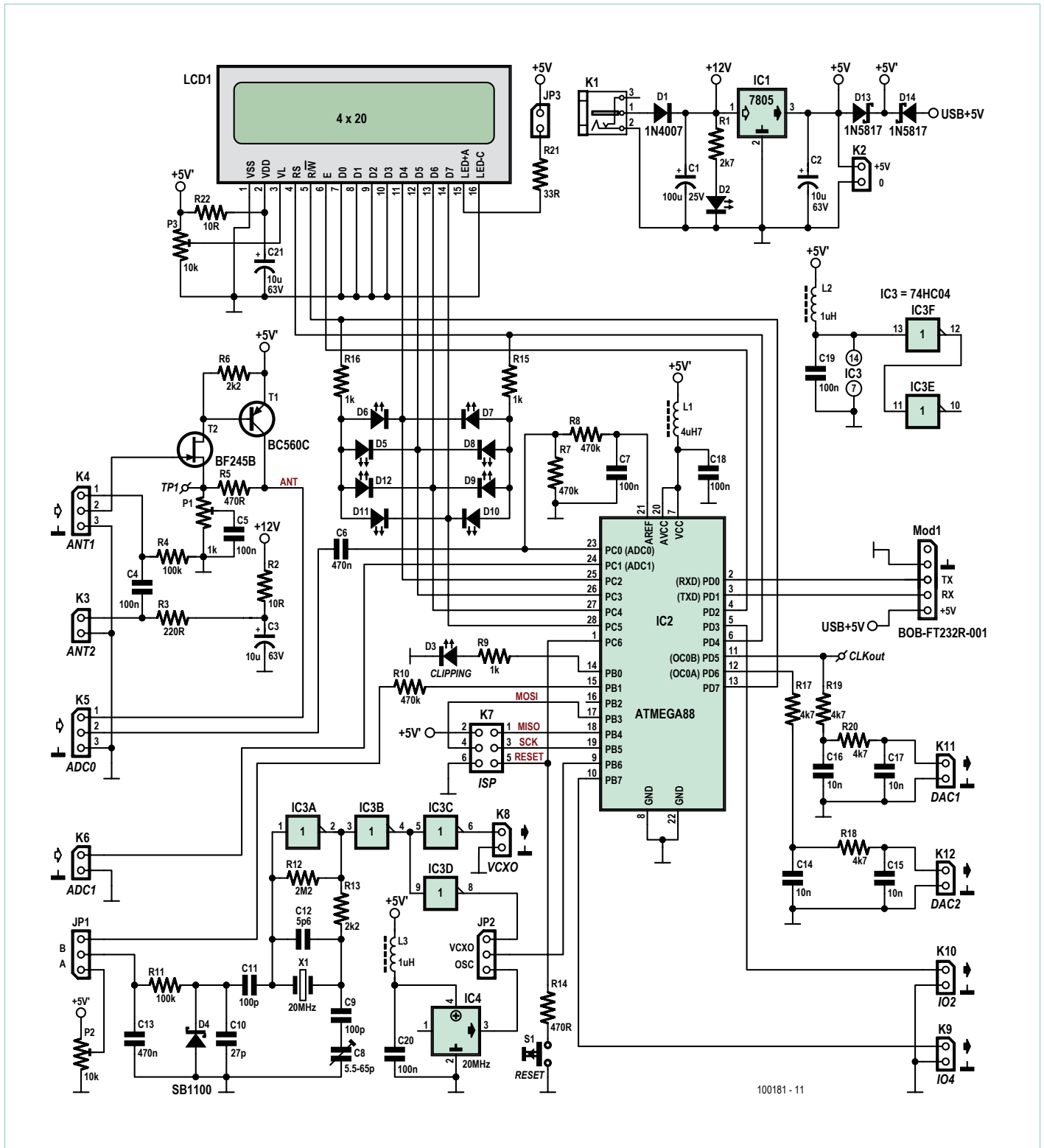

Figure 5. Circuit diagram of our universal receiver board.

COMPONENT LIST

Resistors (5%)

R1 = 2.7k Ω
 R2,R22 = 10 Ω
 R3 = 220 Ω
 R4,R11 = 100k Ω
 R5,R14 = 470 Ω
 R6,R13 = 2.2k Ω
 R7,R8,R10 = 470k Ω
 R9,R15,R16 = 1k Ω
 R12 = 2.2M Ω
 R17,R18,R19,R20 = 4.7k Ω
 R21 = 33 Ω
 P1 = 1k Ω 20%, 0.15W trimpot
 P2,P3 = 10k Ω 20%, 0.15W trimpot

Capacitors

C1 = 100 μ F 25V, radial
 C2,C3,C21 = 10 μ F 63V, radial
 C4,C5,C7,C18,C19,C20 = 100nF 50V
 C6,C13 = 470nF 63V
 C8 = 5.5–65pF 150V trimmer
 C9,C11 = 100pF 5% 100V
 C10 = 27pF 2% 100V
 C12 = 5.6pF \pm 0.25pF 100V
 C14,C15,C16,C17 = 10nF 5% 50V

Inductors

L1 = 4.7 μ H, 190mA, 1.7 Ω
 L2,L3 = 1 μ H, 270mA, 0.8 Ω

Semiconductors

D1 = 1N4007
 D2,D3,D5–D12 = LED, red
 D4 = SB1100
 D13,D14 = 1N5817
 T1 = BC560C
 T2 = BF245B
 IC1 = 7805
 IC2 = ATmega88-20PU, programmed
 IC3 = 74HC04
 IC4 = 20MHz oscillator module

Miscellaneous

X1 = 20MHz quartz crystal, 50ppm
 S1 = pushbutton SPST-NO, 6mm footprint
 K1 = low voltage adapter socket
 K2,K6,K8 = 2-pin pinheader, right angled, lead pitch 0.1 in. (2.54mm)
 K3,K9–K12,JP3 = 2-pin pinheader, lead pitch 0.1 in. (2.54mm)

K4,K5,JP1,JP2 = 3-pin pinheader, lead pitch 0.1 in. (2.54mm)
 K7 = 6-pin pinheader, lead pitch 0.1 in. (2.54mm)
 JP1,JP2,JP3 = jumper 0.1 in. (2.54mm)
 CLKout,TP1 = PCB solder pin

4 IC pin receptacles (for IC4)
 Mod = 5-way pinheader for Elektor BOB-FT232R-001
 LCD1 = 4x20 LCD e.g. HC200401C-YF62L-VA
 PCB # 100181-1

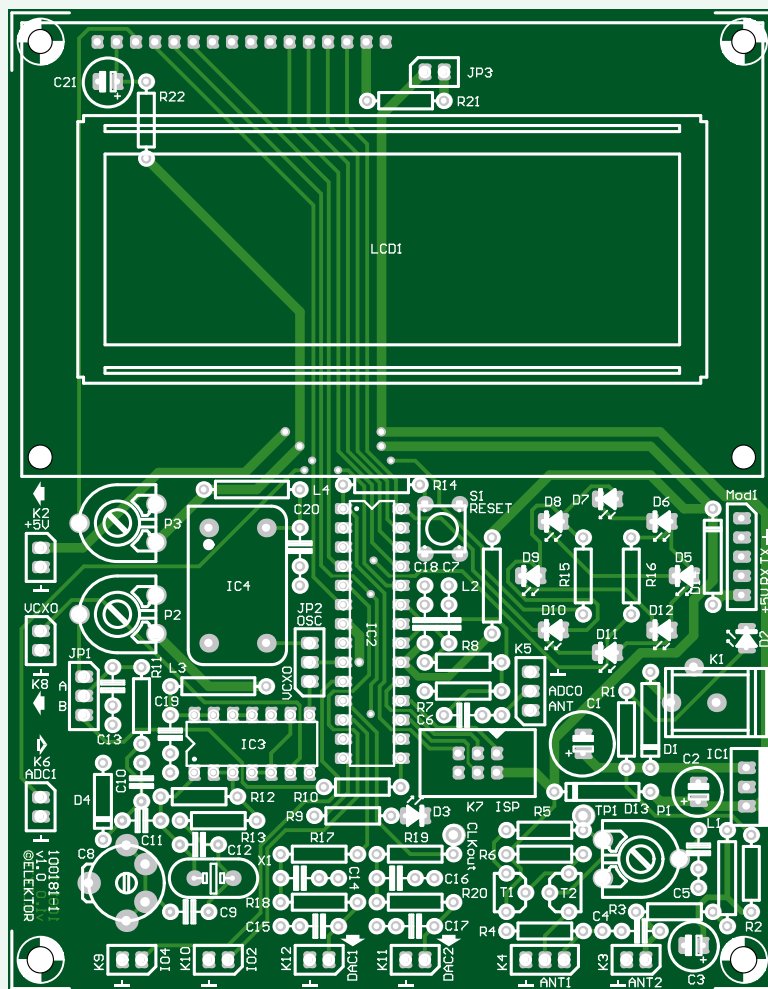

Figure 6. The printed circuit board is available from Elektor as part of a kit including all the components.

attenuate the PWM frequency component in these output signals, each is passed through a two-stage RC low-pass filter.

The circuit is straightforward enough to be built on a small piece of prototyping board. Things are made even easier if the Elektor universal receiver board is used: its circuit diagram is shown in Figure 5. As was the case for the signal generator described in the first part of this series [1], this is available as a kit including the printed circuit

board (Figure 6) and all components. This is a good option, as populating the board is not a tricky task. As you can see from the circuit diagram the universal receiver board includes all the components of the simple front end, but also allows for a wide range of additional future possibilities that we will look at later on in this series. For example, it is possible to connect an active ferrite antenna: an example of such an antenna is again available as an Elektor kit, and

Listing 1: Calculating the quadrature components

```

U=0 ;
if (sampleTime==0){ U=  ADCv ; }
if (sampleTime==2){ U= - ADCv ; }
U3=U2 ; U2=U1 ; U1=U0 ; U0=U ;
X=U0+U1+U2+U3 ;
OCR0A=128+X/8 ;

V=0 ;
if (sampleTime==1){ V=  ADCv ; }
if (sampleTime==3){ V= - ADCv ; }
V3=V2 ; V2=V1 ; V1=V0 ; V0=V ;
Y=V0+V1+V2+V3 ;
OCR0B=128+Y/8 ;
    
```

the electronics and printed circuit board will be described in the next installment in this series.

... and the software...

The software, as always, is available as source code and as a hex file for download from the Elektor web site [2]. For our first experiment the software we use is called `EXP-SimpleFrontend-2kHz-IQout-V01.c`.

The program samples the input signal at a rate of 20 MHz / 5000 = 8 kHz. The signal is then mixed with a 2 kHz signal. A simple low-pass filter then produces the *X* and *Y* outputs, which we can also label as the quadrature components *I* and *Q*.

Listing 1 shows the heart of this routine. The timer variable `sampleTime` always counts cyclically from 0 to 3, and thus represents the current phase of the local oscillator. The variables *U* and *V* are used to hold the values that are obtained by multiplying the input value `ADCv` by the cosine sequence [1, 0, -1, 0] and the sine sequence [0, 1, 0, -1] respectively. The values of *U* and *V* are then fed into a simple low-pass filter that calculates a rolling average over sets of four samples. The results of this calculation, *X* and *Y*, are the in-phase and quadrature components of the signal and are written to the PWM registers `OCR0A` and `OCR0B` respectively.

... and, finally, testing

To test the receiver, we feed a sinewave signal from our signal generator into the front end hardware via a 10 kΩ potentiometer to allow adjustable attenuation. We use the SINE OUT (K3) output of

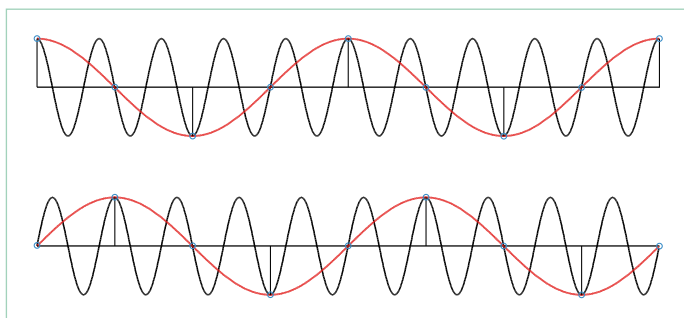

Figure 7. Sampling a 10 kHz signal and a 2 kHz signal (red) at 8 kSa/s.

the signal generator and the program called `EXP-SinusGenerator-DDS-ASM-C-V01`; the wiper of the potentiometer is connected to input `ADC0` on the receiver board.

The analog outputs `DAC1` and `DAC2` are connected to an oscilloscope operating in X-Y mode. Then we instruct the signal generator over its RS-232 interface to generate a 2 kHz sinewave [1] and adjust the amplitude of the signal using the potentiometer until the red LED (D3 in Figure 5) does not quite light. The front end is then being driven to its maximum level, just short of clipping. The oscilloscope should show a single point that moves slowly in a circle. In theory the point should be stationary, but because the oscillator controlling the front end is not running at exactly the same frequency as that controlling the signal generator, the point will move.

To see the effect more clearly, adjust the signal generator to produce a frequency of 2005 Hz. Then the point will move in a circle making five revolutions per second. With the signal generator set to 1995 Hz, the point will again move at five revolutions per second, but in the opposite direction. Adjusting the amplitude of the input signal using the potentiometer affects the radius of the circle in which the point moves.

Our 'I-Q demodulator' has mixed the signal in the band around 2 kHz down to a center frequency of 0 Hz. Signals in sidebands above and below 2 kHz are now distinguished in the direction of rotation of the point on the oscilloscope display. Now frequencies around 2 kHz are of relatively little practical interest: more interesting are frequencies in the longwave bands used (in Europe) for sending data by various transmitters. This requires one further small step, as we shall see in the next section.

The road to RF

The Nyquist-Shannon sampling theorem states that a sample rate of at least $2f$ is required to represent losslessly a signal containing frequency components up to a frequency *f*. Using a lower sample rate than this is called 'undersampling' or 'sub-Nyquist sampling'. Take a look at **Figure 7**. The time interval illustrated is 1 ms long. The upper black curve is a cosine wave, with the corresponding sine wave below, both at 10 kHz. As before, the signal is sampled at 8 kSa/s (kilosamples per second), giving sample values indicated by the small blue circles. With conventional sampling we need at least two samples per period of the 10 kHz signal, but here we have less than one sample per period: hence the signal is undersampled. The sequence of sample values that we obtain is [1, 0, -1, 0, 1, 0, -1, 0, 1] for the upper signal and [0, 1, 0, -1, 0, 1, 0, -1, 0] for the lower one. Superimposed on the figure, in red, are 2 kHz cosine- and sinewaves. For these signals the sample rate of 8 kSa/s satisfies the sampling theorem; but the surprise is that the 2 kHz signal and the 10 kHz signal give rise to the same set of sample values. This means that a 10 kHz signal sampled at 8 kSa/s is indistinguishable from a 2 kHz signal sampled at the same rate. In turn this means that our front end, which uses an 8 kSa/s sample clock, can equally well be used to demodulate signals at 10 kHz.

There is of course a full theoretical analysis of the above phenomenon, known as the Nyquist-Shannon sampling theorem for band-

BPSK and QPSK modulation schemes

A special case of phase modulation is binary phase shift keying (BPSK), where the bit values zero and one are encoded by signals 180 degrees out of phase with respect to each other. This cannot be done using the PWM method described in the text. However, we can take advantage of the settings available in the AVR's registers to select whether the event TimerValue == CompareValue results in a positive-going or negative-going edge on the output: in other words, we can selectively invert the PWM output. Introducing this possibility has the effect of adding a further circle to the diagram shown in Figure 11, as shown in the figure here.

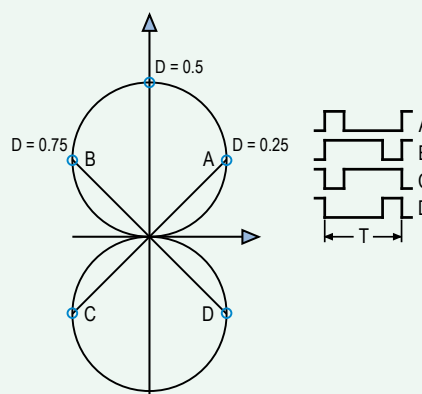

In particular we now have four signal shapes (represented by the points A, B, C and D) that are spaced at 90 degree phase intervals. This lets us implement QPSK (quadrature phase-shift keying) modulation. If we restrict ourselves to just a pair of diametrically opposite points (for example, A and C) we have the choice of two signals with phases 180 degrees apart: this gives us BPSK modulation. Our PWM generator thus covers all the most important modulation schemes. They are all implemented in the program code and can be selected by invoking the appropriate preprocessor directive.

pass signals. One consequence of this theorem is that a sampled bandpass signal with bandwidth B starting at a multiple of the sample rate f_s can be reconstructed perfectly as long as $B < f_s / 2$. In particular, we can reconstruct a bandpass signal with components stretching from $n \times f_s$ to $n \times f_s + f_s / 2$ for any chosen integer n ; or, stated another way, a bandpass signal centered at $n \times f_s + f_s / 4$ with total bandwidth up to $f_s / 2$. In particular, if we have a sample rate of 8 kHz we can demodulate signals equally well around any of the following frequencies: 2 kHz, $2 \text{ kHz} + 1 \times 8 \text{ kHz} = 10 \text{ kHz}$, $2 \text{ kHz} + 2 \times 8 \text{ kHz} = 18 \text{ kHz}$, $2 \text{ kHz} + 3 \times 8 \text{ kHz} = 26 \text{ kHz}$, ..., $2 \text{ kHz} + 20 \times 8 \text{ kHz} = 162 \text{ kHz}$, and so on. We can easily test this, for example by setting the signal generator frequency to 26005 Hz.

For undersampling like this to be successful the signal being sampled must be band-limited, for example by the insertion of a bandpass filter in front of the AVR. Image frequencies at $n \times f_s - f_s / 4$ are also received: in our case these images are at $8 \text{ kHz} - 2 \text{ kHz} = 6 \text{ kHz}$, $2 \times 8 \text{ kHz} - 2 \text{ kHz} = 14 \text{ kHz}$, ..., $25 \times 8 \text{ kHz} - 2 \text{ kHz} = 198 \text{ kHz}$, and so on.

So far we have assumed that the signal is perfectly digitized, and of course that is not the case. The sample-and-hold stage in any ADC has a so-called 'aperture', and a result of this is that it is not possible to mix down very high frequencies using the AVR. However, in the next part of this series, we will see how a signal transmitted by the BBC on 648 kHz (in the mediumwave band!) can easily be decoded.

Amplitude and phase

The signals X and Y give the strength of the in-phase and quadrature components of the input signal. However, we are rather more interested in its amplitude A and phase ϕ , since one of our ultimate aims is to decode amplitude- and phase-modulated signals. If we had fast floating-point arithmetic we could compute the amplitude and phase from the X and Y coordinates using the following two statements.

$$A = \text{sqrt}(X * X + Y * Y);$$

$$\text{PHI} = \text{atan2}(Y, X);$$

The program `EXP-SimpleFrontend-2kHz-Phase-Ampl-V01.c` calculates phase and amplitude using a rather more efficient method and outputs the results on DAC1 and DAC2. The output voltage level representing amplitude is logarithmically scaled, enabling a direct conversion to dB. **Figure 8** shows how the phase of the signal transmitted by the BBC on 198 kHz changes over time. The signal was received using an active ferrite antenna whose amplified output is fed into the receiver's front end. Antenna input ANT2 on the receiver board can be used for this purpose, with pin 1 of K4 linked to pin 2 of K5 so that the signal appears on input ADC0 of the microcontroller. Again we use a sample rate of 8 kHz. Since $198 \text{ kHz} = 25 \times 8 \text{ kHz} - 2 \text{ kHz}$, the signal of interest is mixed down to 2 kHz. The BBC transmission includes digital data sent using a phase modulation of ± 22.5 degrees at a rate of 25 bit/s. This digital modulation can clearly be observed in the mixed-down signal.

FM, PM and AM — with PWM

Next we want to try to generate some modulated signals ourselves. First install the program `EXP-SQTX-125kHz-PWMA-V01.c` into

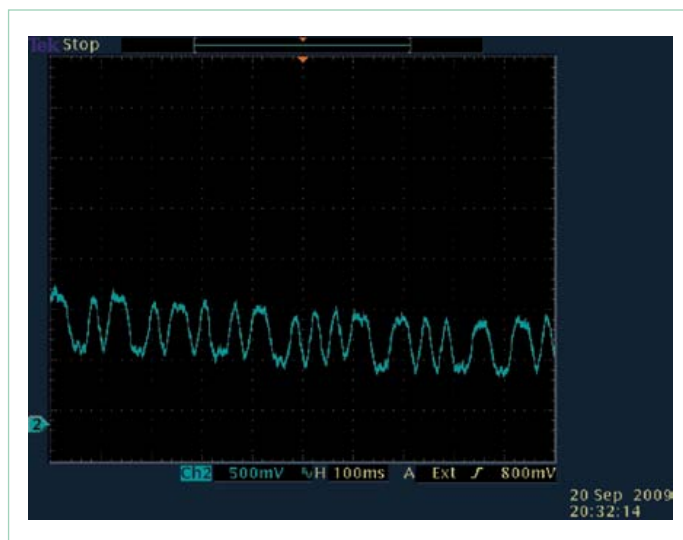

Figure 8. Phase modulation observed on a BBC 198 kHz (Droitwich) transmission.

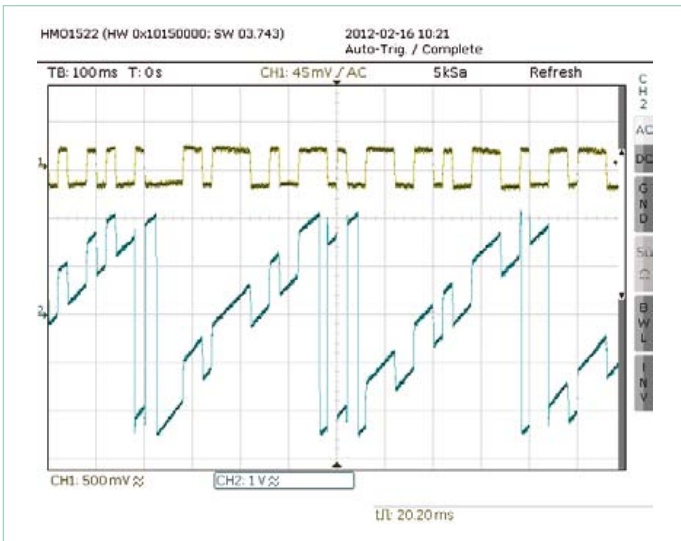

Figure 9. Pulsewidth modulation: amplitude shown in yellow, phase in blue.

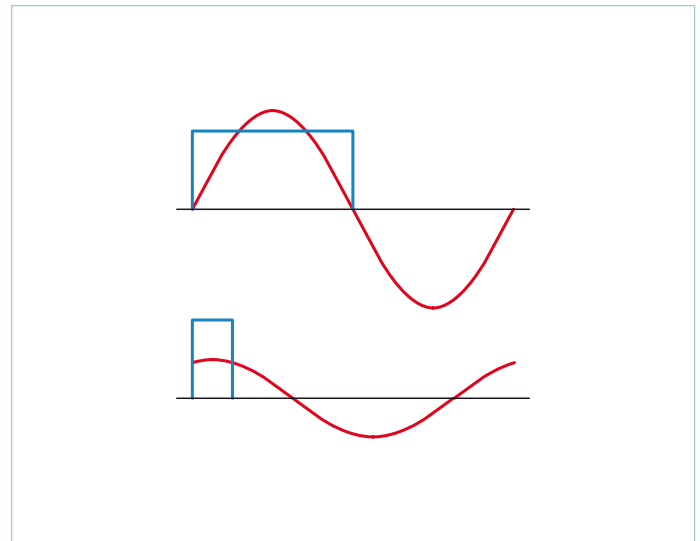

Figure 10. Pulsewidth modulation ($D = 0.5$ and $D = 0.125$).

the signal generator’s microcontroller. The 125 kHz squarewave output by this code is filtered using the resonant circuit described in part 1 of this series [1] into a sinewave. Feed this signal into the ADC0 input of the receiver front end. This circuit arrangement will be used for the following experiments.

With the program `EXP-SimpleFrontend-125kHz-Phase-Ampl-V01.c` running in the front end the outputs will represent the amplitude and phase of the received 125 kHz signal. Again the amplitude output is logarithmically scaled so that a wider dynamic range can be represented: an output voltage of 4 V corresponds to an input amplitude of 1 V_{pp} and a step of 20 dB in amplitude gives a change of 1 V in the output level. A phase output voltage of 5 V represents a phase angle of exactly 360°.

In the PWM code mentioned above a range of different modulation schemes and data sequences can be selected using `#define` preprocessor directives. First we will try straightforward PWM, where the frequency of a squarewave remains constant but its mark-space ratio is modulated. The bit transmission routine simply loads the modulating value into PWM register OCR1A (Listing 2).

The period is fixed at 160, which means that the output frequency is $20 \text{ MHz} / 160 = 125 \text{ kHz}$. The duty cycle is switched between $D = 80 / 160 = 0.5$ and $D = 20 / 160 = 0.125$. Figure 9 is an oscilloscope trace showing the resulting variation in amplitude and phase. It is clear that both of these quantities are modulated, the amplitude

varying by 0.4 V (which, as 1 V corresponds to 20 dB, means 8 dB). The phase variation is trickier to analyze. The first point to note is that the phase jumps, in line with the data bit being transmitted, by about 0.92 V. This corresponds to $0.92 / 5 \times 360 = 66$ degrees. On top of this is superimposed a slow sawtooth signal with a slope (read from the oscilloscope trace) of about 5 V in 0.5 s. Now, 5 V corresponds to a phase angle of 360 degrees, and so the phase angle is making approximately two complete revolutions every second. The reason for this is again that the transmitter and receiver have very slightly different ideas of what ‘125 kHz’ means: in fact, in this case they differ by 2 Hz. We will need to be careful to allow for this effect in future experiments. An error of 2 Hz in 125 kHz corresponds to 16 ppm, which is rather better than the typical ± 50 ppm tolerance of a crystal oscillator. It is possible to compensate for this drift using a PLL control loop to drive the oscillator in the receiver.

A more refined kind of modulation

The above is all very well, but we would naturally like to implement pure amplitude modulation. And likewise, when implementing phase modulation, we would like to alter only the phase of the signal and not the amplitude. To that end we need to understand better what is happening in the PWM system.

Figure 10 shows the squarewave signal with the two different mark-space ratios $D = 0.5$ and $D = 0.125$, in each case accompanied by the sinewave signal that results after extracting just the funda-

Listing 2: Modulation using simple PWM

```
void bitSend(uint8_t theBit){
  if (theBit) {
    OCR1A = 80 ;
  }
  else {
    OCR1A = 20 ;
  }
}
```

Listing 3: PWM modified for pure phase modulation

```
void bitSend(uint8_t theBit){
  if (theBit) {
    OCR1A = 80+10 ;
  }
  else {
    OCR1A = 80-10 ;
  }
}
```

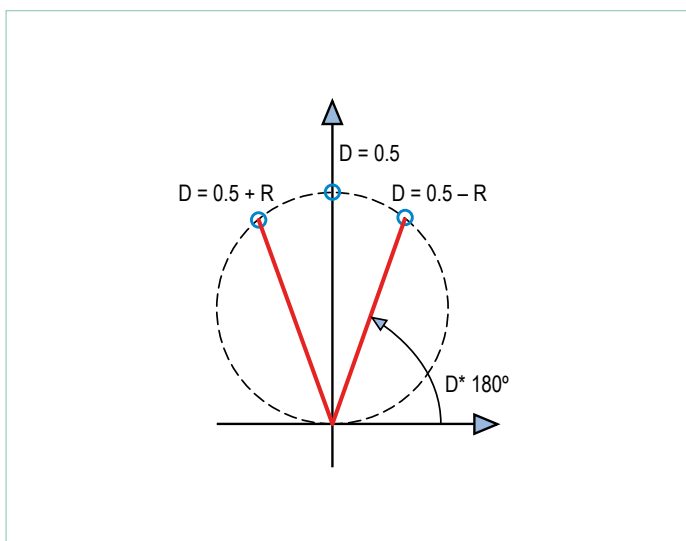

Figure 11. With judicious choice of mark-space ratios it is possible to achieve pure phase modulation.

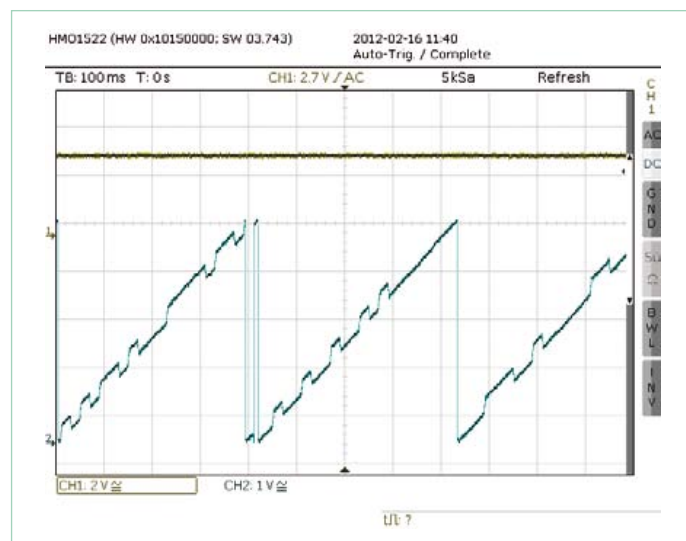

Figure 12. Pure phase modulation: amplitude shown in yellow, phase in blue.

mental component using the 125 kHz resonant circuit. The filtered sinewave reaches its peak exactly in the middle of the squarewave pulse. The mid-point moves when the mark-space ratio is changed, and so there is a phase shift when the mark-space ratio is changed.

In our example, when we use a mark-space ratio of $D = 0.5$ the phase angle is 0.5×180 degrees, or 90 degrees. When using a mark-space ratio $D = 0.125$ the corresponding phase angle is 0.125×180 degrees, or 22.5 degrees. The difference between these two phase angles is $90 - 22.5 = 67.5$ degrees, which is in close agreement with the measured value from Figure 9 of 66 degrees.

With a little more mathematics we can also calculate the amplitude variation as a function of the mark-space ratio D . The peak-to-peak amplitude \hat{A} of the sinewave is given by the formula

$$\hat{A} = 5V \times (4 / \pi) \sin \pi D$$

and from this we can determine that the amplitude ratio between the cases $D = 0.5$ and $D = 0.125$ should be $0.3826834... = -8.343$ dB. Again, this is in good agreement with the value of 8 dB measured from Figure 9.

The relationship given above can also be illustrated graphically. **Figure 11** shows how we can determine the amplitude that we will obtain with a given mark-space ratio D . Construct a line from the

origin of the plot inclined at an angle of $D \times 180$ degrees to the point where it intersects the indicated circle. The length of this line then gives the amplitude. As can be seen, the amplitude is maximal when $D = 0.5$, and for any R , mark-space ratios of $D = 0.5 - R$, and $D = 0.5 + R$ give the same amplitudes. We can therefore use a pair of such values to create pure phase modulation without an amplitude component, and this is exactly what our PWM generator does when it is switched to PM mode using a #define directive. The essential part of this code is shown in **Listing 3**.

Figure 12 shows the result. The phase switches constantly between the two values that represent zero and one. Superimposed on this is a small drift due to the frequency error. The amplitude (yellow curve) is constant.

In the next instalment in this series we will look at how we can achieve pure amplitude modulation. However, we will not just be looking at this in theory: we will also implement a DCF test transmitter and receive DCF signals. DCF is a German time standard transmitter.

(100181)

Internet Links

- [1] www.elektor.com/100180
- [2] www.elektor.com/100181

Elektor Products and Support

- * Signal generator (kit including printed circuit board and all components): # 100180-71
- * Universal receiver (kit including printed circuit board and all components): # 100181-71
- * Active ferrite antenna (kit including printed circuit board and all components): # 100182-71
- * Combined kit (all three of the above): # 100182-72

- * BOB-FT232R USB-to-TTL converter, ready built and tested: # 110553-91
- * USB AVR programmer, printed circuit board with SMD parts fitted, plus all other components: # 080083-71
- * Free software download (hex files and source code)

All products and downloads are available via the web pages accompanying this article: www.elektor.com/100181

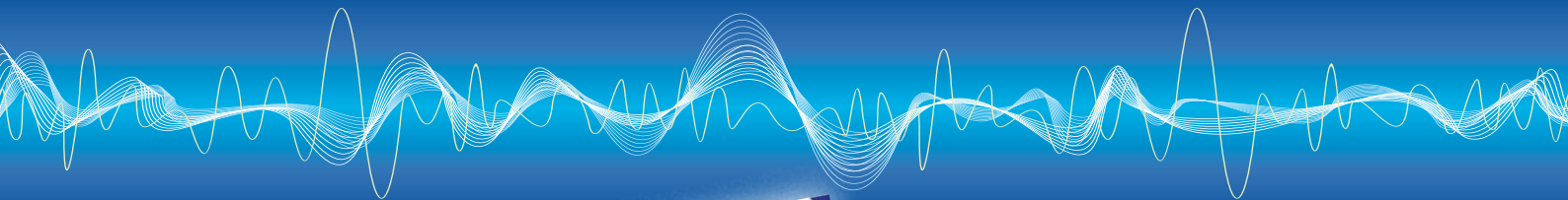

Hackerspace:

Of course Elektor's lab isn't the only place where ideas are born, projects are created and knowledge is gathered and spread. There are probably hundreds of

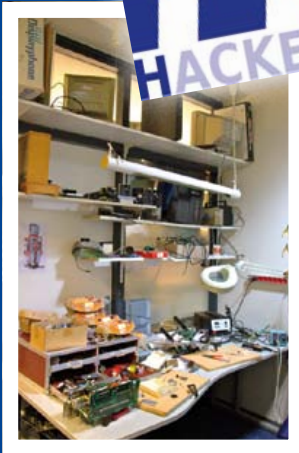

Hack42's webspace:
hack42.nl

Photographs:
D. van Zuijlekom

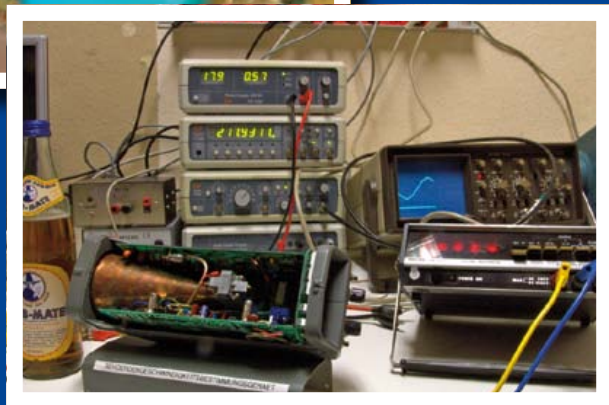
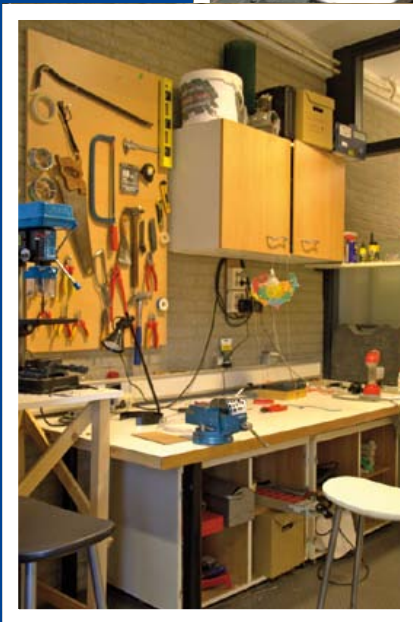

No lack of workspaces
and equipment.

Hack42, Arnhem, The Netherlands

other 'communities' all over the world where people with the same mind set gather to work on their projects and ideas and brush up on their knowledge and skills and socialize. Here we give you a brief peek into the hackerspace of a Dutch group of enthusiasts located in Arnhem. Meet Hack42.



Umbrellabat
is watching you!



A Lab
Monkey
- every
hackerspace
needs one!

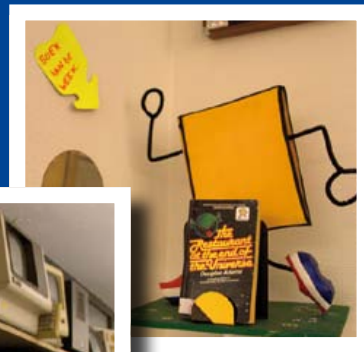

Book Xing
- where
literary
masterpieces
are passed
on.

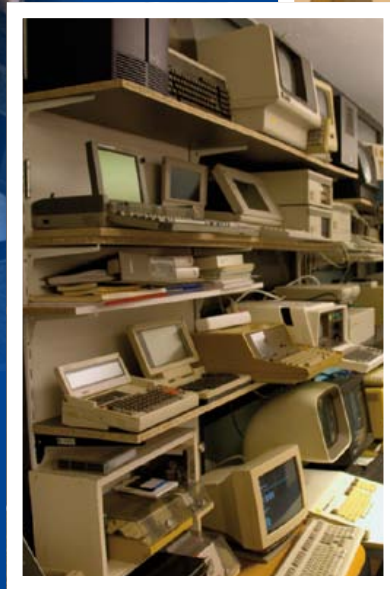

The PC Museum.
How far back do you want to go?

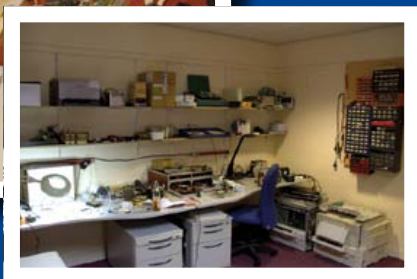
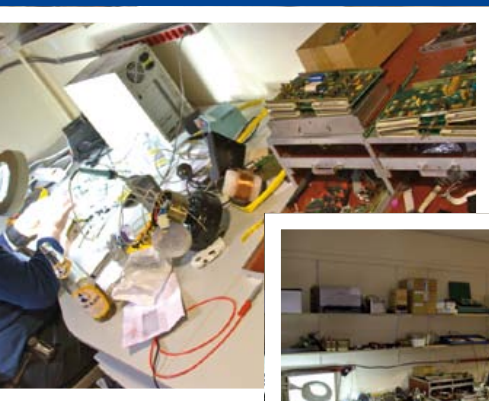

You too got an awesome hackerspace and
want the world to know?
Mail us at editor@elektor.com



Developing and learning

FLOWCODE5

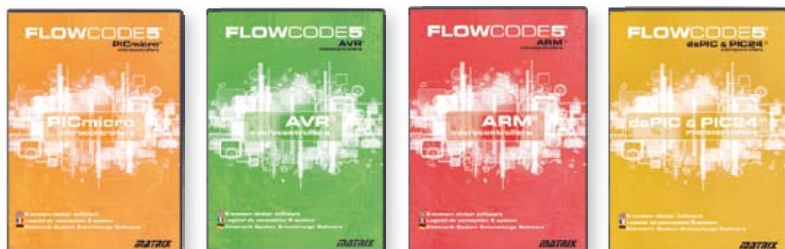

Flowcode 5 is one of the world's most advanced graphical programming languages for microcontrollers (PIC, AVR, ARM and dsPIC/PIC24). The great advantage of Flowcode is that it allows those with little to no programming experience to create complex electronic systems in minutes.

www.elektor.com/flowcode

... for electronics

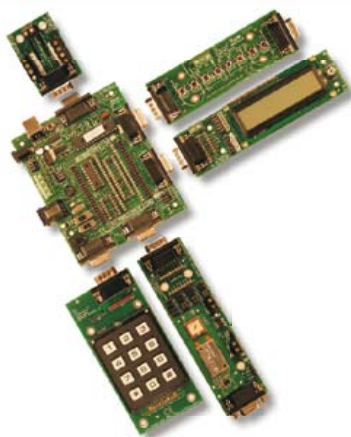

E-Blocks are small circuit boards each of which contains a block of electronics that you would typically find in an electronic or embedded system. There are more than 40 separate circuit boards in the range; from simple LED boards to more complex boards like device programmers, Bluetooth and TCP/IP. E-blocks can be snapped together to form a wide variety of systems that can be used for teaching/learning electronics and for the rapid prototyping of complex electronic systems. Separate ranges of complementary software, curriculum, sensors and applications information are available.

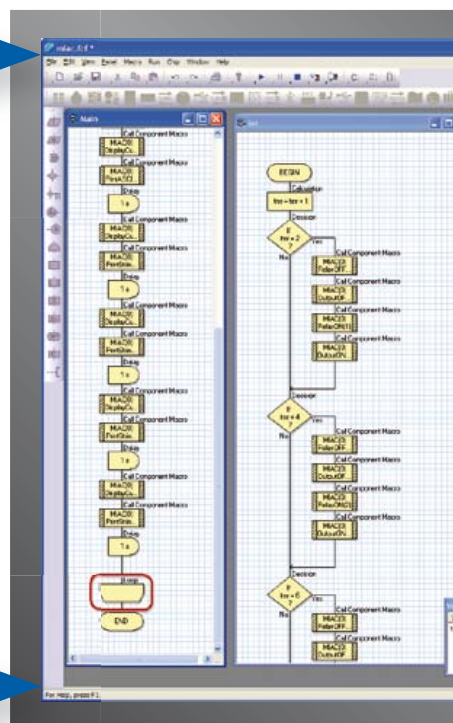

... for industrial control



MIAC (Matrix Industrial Automotive Controller) is an industrial grade control unit which can be used to control a wide range of different electronic systems including sensing, monitoring and automotive. Internally the MIAC is powered by a powerful 18 series PICmicro device which connects directly to the USB port and can be programmed with Flowcode, C or assembly. Flowcode is supplied with the unit. MIAC is supplied with an industrial standard CAN bus interface which allows MIACs to be networked together.

Flowkit

Flowkit provides In Circuit Debugging for a range of Flowcode applications for PIC and AVR projects:

- Start, stop, pause and step your Flowcode programs in real time
- Monitor state of variables in your program
- Alter variable values
- In circuit debug your Formula Flowcode, ECIO and MIAC projects



ng with Flowcode 5

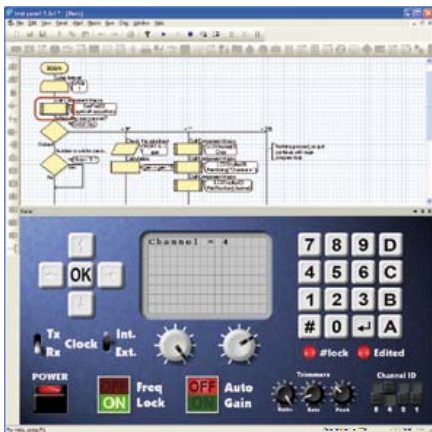

New features in Flowcode 5

Flowcode 5 is packed with new features that make development easier including:

- New C code views and customization
- Simulation improvements
- Search and replace function
- New variable types and features, constants and port variables
- Automatic project documentation
- New project explorer makes coding easier
- Implementation of code bookmarks for program navigation
- Complete redesign of interrupts system allows developers access to more chip features
- Compilation errors and warnings navigate to icons
- Disable icons feature
- Improved annotations
- Improved links to support media
- Support for MIAC expansion modules and MIACbus

... for robotics

Formula Flowcode is a low cost robot vehicle which is used to teach and learn robotics, and to provide a platform for competing in robotics events. The specification of the Formula Flowcode buggy is high with direct USB programming, line following sensors, distance sensors, 8 onboard LEDs, sound sensor, speaker and an E-blocks expansion port. The buggy is suitable for a wide range of robotics exercises from simple line following through to complete maze solving. E-blocks expansion allows you to add displays, connection with Bluetooth or Zigbee, and GPS.

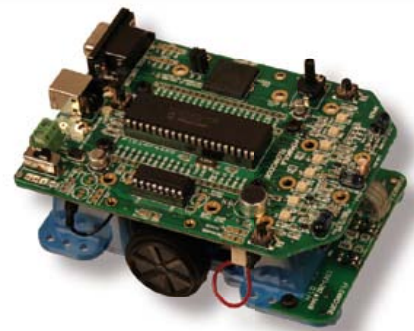

... for USB projects

ECIO devices are powerful USB programmable microcontrollers with either 28 or 40 pin standard DIL (0.6") footprints. They are based on the PIC 18 series and ARM 7 series microcontrollers. ECIO is perfect for student use at home, project work and building fully integrated embedded systems. ECIO can be programmed with Flowcode, C or Assembly and new USB routines in Flowcode allow ultra rapid development of USB projects including USB HID, USB slave, and USB serial bus (PIC only). ECIO can be incorporated into your own circuit boards to give your projects USB reprogrammability.

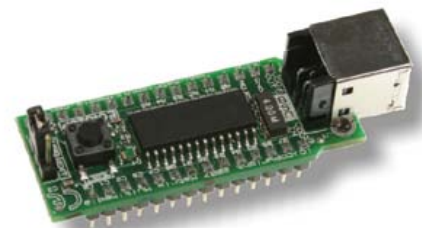

More information and products at:
www.elektor.com/eblocks

Thermometer using Giant Gottlieb® Displays

By Ludovic Mézière (France)

You don't know Mr Gottlieb? Well, come to my swimming pool and you'll be able to meet him. And at the same time you can attend the happy marriage of an electromechanical display recovered from a 1960s pinball machine and some modern programming techniques. *It is more fun to compete!*

The idea for this rather original project came to me when I was trying to fit a water-temperature indicator for an outdoor swimming pool. I needed this display to be readable from over 10 m (30 ft.) away, in full sunlight, and with power consumption as close to zero as possible. Illuminated displays were ruled out right away, since no current types can meet the above constraints, especially the last one. I looked around for quite a while before finally coming across the reels of a pinball scoring unit, which do meet my specifications. Once the temperature is displayed, the consumption of my circuit drops to zero, but the temperature display remains perfectly visible. There are no batteries (dry or rechargeable), adjustments, or maintenance.

Gottlieb® displays

On many early to mid 1960s pinball machines, to display each player's score, large wheels ('reels'), a good 4 inches or so in diameter, placed side by side behind a glass window, display the figures 0 to 9 in turn. These reels are self-contained, each with its own electromagnet that increments a mechanism that's indestructible (Figure 1). Depending on the model and the number of points to be displayed, three, four, or even five reels would be used to form a counter. You really can't help admiring the manufacturing quality of these units, as well as their utter reliability.

Their operating voltage is 24 VAC and a short pulse is all it takes to advance the angular rotation by one step. Depending on the model of reel, several contacts are available, but for our application we only need one as a reference point — the contact that opens when the wheel is indicating '0'. So all we're going to need is the two wires for powering the electromagnet and the two wires for detecting the '0' for each reel.

Ingenious supply

This circuit (Figure 2) has a second special feature, less visible than the display, but no less interesting: its power supply. This is provided by a transformer supplying the AC supply for the electromagnets at 24 V and the 5 VDC rail for the rest of the electronics. But instead of being continuously powered night and day as one might expect for a circuit of this sort, it will only be powered when the wheels actually need to turn. The rest of the time, the board's stand-by voltage is supplied by a 1 farad capacitor (C3). Thus the AC powerline consumption is zero except when the reels are turning. The

temperature is measured every 15 minutes, and the display is only refreshed if the temperature has changed.

Obviously, we're going to use a microcontroller to control the operation of the thermometer, involving three distinct tasks:

- communicating with the temperature sensor (IC5) via an I²C bus;
- driving the two Gottlieb® wheels;
- switching the power supply between display cycles.

As you might expect, the configuration of the circuit diagram is rather unorthodox. Let's start, though, with the conventional bit. The Atmel ATTiny2313 microcontroller

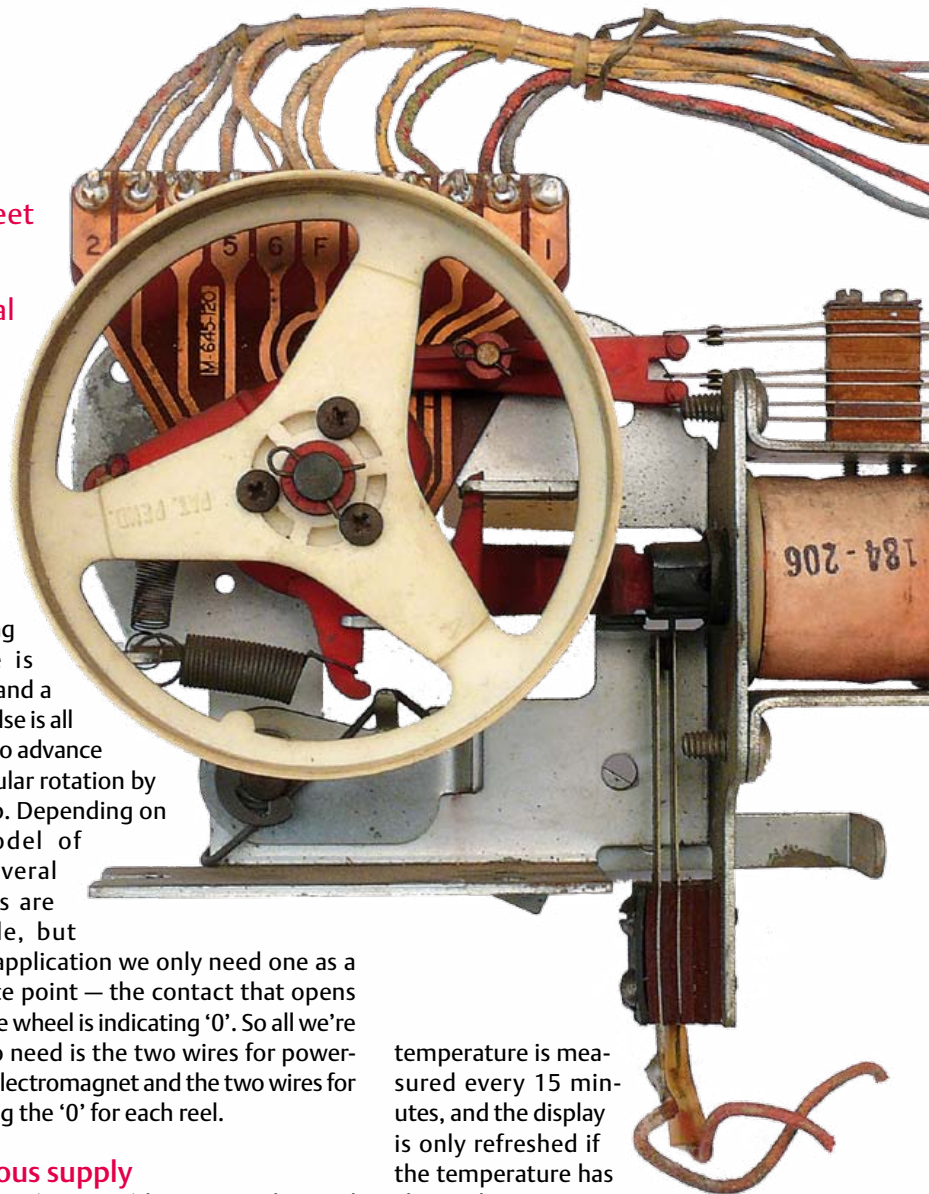

Original, self-sufficient and readable from a distance in all weathers

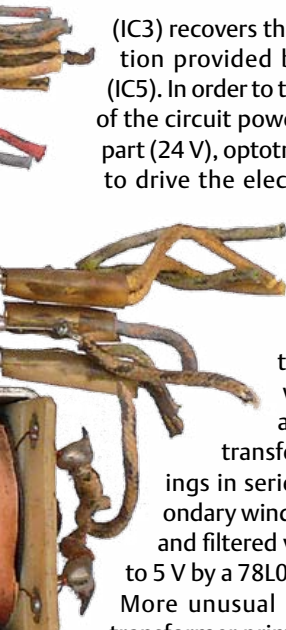

(IC3) recovers the temperature information provided by the TMP100 sensor (IC5). In order to totally isolate the section of the circuit powered at 5 V from the AC part (24 V), optotriacs (IC4 & IC6) are used to drive the electromagnets. Then, for each of the two reels, a T1235 triac – perhaps a little over-specified – has the job of switching the power to the electromagnet windings. The 24 VAC is achieved by wiring the transformer's two 12 V windings in series. One of the two secondary windings supplies a rectified and filtered voltage regulated down to 5 V by a 78L05 (IC1).

More unusual is the way the supply transformer primary is switched using a triac (Tri1), driven from the microcontroller via an optotriac (IC2). This turns the AC line

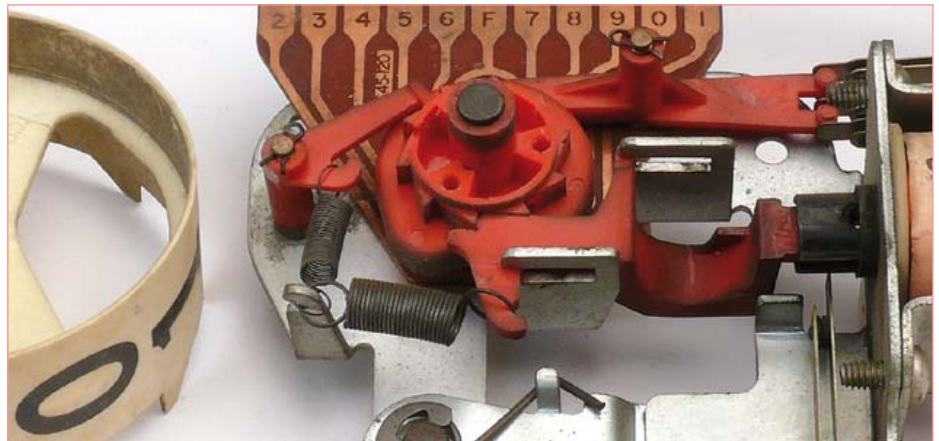

Figure 1. Ten years from now, the electronic components in my thermometer may perhaps have failed – but this mechanism will undoubtedly still be going strong!

voltage off completely as soon as it has finished measuring and displayed the temperature. The voltage at the output of IC1

collapses at once, but not on the cathode of D1! The charge on this 1 farad reservoir capacitor is enough to power the micro-

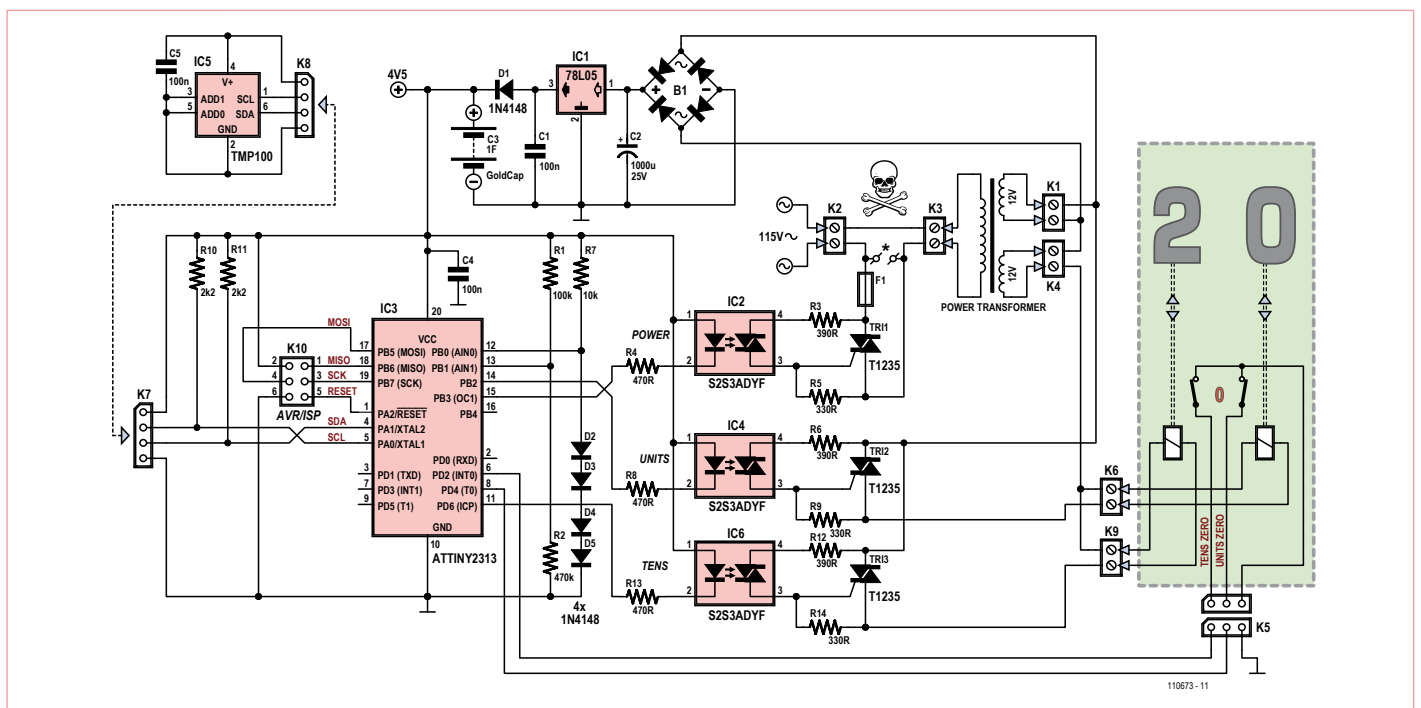

Figure 2. Take a close look at the circuit for this thermometer using Gottlieb reels, it includes a number of unusual features. It can also be used as a wiring guide.

COMPONENT LIST

Resistors

R1 = 100k Ω
 R2 = 470k Ω
 R3,R6,R12 = 390 Ω
 R4,R8,R13 = 470 Ω
 R5,R9,R14 = 330 Ω
 R7 = 10k Ω
 R8 = 2.2k Ω

Capacitors

C1,C4 = 100nF (5mm)
 C2 = 1000 μ F 35V radial
 C3 = 1F 5.5V
 C5 = 100nF SMD 0805

Semiconductors

D1–D5 = 1N4148
 B1 = 100Vpiv 1.5A bridge rectifier, round
 IC1 = 78L05
 IC2,IC4,IC6 = S253ADYF (triac optocoupler)
 IC3 = ATTINY2313-20PU, programmed,
 Elektor # 110673-1
 IC5 = TMP100
 Tri1,Tri2,Tri3 = T1235H-6G

Miscellaneous

AC power transformer, 40VA, primary 2x115V,
 secondary 2x12V (e.g. Block RK40/12)
 F1 = fuse, 160mA @240V (315mA @115 V)
 K1,K4,K6,K9 = PCB screw terminal (5mm)

K2,K3 = PCB screw terminal (7.5mm)
 K5 = 3-pin pinheader
 K7,K8 = 4-pin pinheader
 K10 = 6-pin (2x3) pin pinheader

* pushbutton, 230VAC (USA: 115VAC) rated.
 PCB # 110673-1

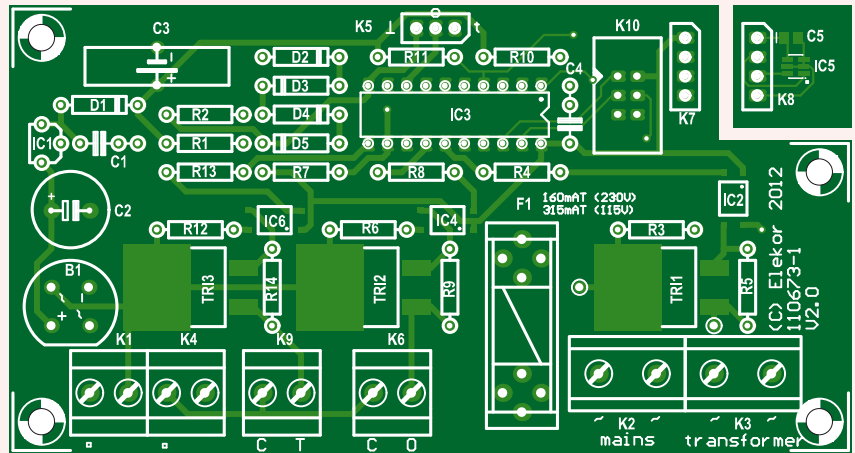

Figure 3. Before starting to fit the components, detach the corner of the thermometer PCB to which the sensor is going to be soldered. Take great care with the dangerous AC powerline voltage wiring.

controller for a certain length of time once the AC power is turned off. During the next 15 minutes, the Tiny2313 devotes itself to two tasks in turn:

- monitoring the 15 minute countdown, at the end of which it will trigger an interrupt and then carry out a temperature reading;
- monitoring its own supply voltage.

The chain of diodes D2–D5 maintains the Tiny2313's analog comparator AIN0 input

(pin 12) at a reference voltage of around 2.4 V, while the divider R1/R4 feeds a voltage proportional to the supply voltage on input AIN1 (pin 13). When this falls below the threshold of the 2.4 V on input AIN0, the comparator output changes state, an interrupt is triggered, and the supply transformer triac is turned on for a few seconds — just long enough to recharge our 1 F capacitor.

Self sufficient

Once the system has been started, the power supply looks after itself. Except that it needs a pulse to start it up when it is first brought into service, and for starting again after the power has been off for a long time. The initial start-up takes place when the microcontroller is programmed *in situ*: the programmer supplies the 5 V voltage needed to transfer the hex file to the

TILT!

The era of electromechanical pinball machines with score counters opened in 1959 with the famous 'Army Navy' made by Williams and ended in 1979 with 'Space Walk' by Gottlieb. Along with Bally, these two pinball manufacturers were by far the most prolific. Their reel-based score counters were constantly improving, with differences between the makes naturally — but all of them are suitable for this thermometer.

When the coil receives a pulse, the reel increments mechanically through an angle of 36°, then the wheel is held in its new position. The rotation operates various contacts: to detect the presence of the solenoid plunger (End Of Stroke), to detect the '9' and indicate 'carry', and to detect the '0', used for initialization.

Certain types of reels even have a PCB with coding via wiping contacts, making it possible to determine the position of the wheel.



ISP connector K10. At the same time, our 1 F reservoir capacitor takes advantage of the opportunity to charge up. Once the program has been loaded and the capacitor charged, the cycle is started and carries on running not unlike a flywheel.

To cope with the effects of the AC line voltage being off for a long time, the solution adopted is less elegant, but just as effective: a pushbutton (capable of handling AC grid voltage) shorts terminals A1 and A2 of triac Tri1 and powers the transformer. Keeping the button pressed for a few seconds powers the transformer long enough to recharge the capacitor: a new cycle begins.

At first switch-on, the software seeks the '0' position for each of the two Gottlieb score reels by making them turn until the opening of the contacts (marked '0' on the circuit)

detachable mini-board (Figure 3), wired back to the main board via a 3-core screened cable (K7 & K8). I've tested this arrangement satisfactorily up to at least 10 m (30 ft.). Potted in silicone, I just slip the sensor probe into the pool.

Software

The choice of microcontroller is not critical, since we're not asking it to do anything particularly clever. It just has to handle:

- one I²C bus as master;
- one internal counter of 15 minutes pprox.);
- one analog comparator;
- two digital inputs;
- three optotriac drive outputs.



you need to write a 0 to this input (see doc2543 ATTiny 2313 at www.atmel.com).

A unique thermometer built from pinball machine parts

on its PD2 and PD4 ports tells the microcontroller the reels have both reached this position. Once the display has been reset to '00', all the microcontroller then has to do is send the right number of pulses to make it display the measured temperature.

The drawback with these wheels is that they can't go backwards: so to go down one digit, you have to make them go all the way round. However, it's only a relative drawback, since a complete rotation takes only 2 s, and moreover, this rapid rotation is a pleasure for the eyes and the ears [1].

So the switching won't produce interference on the AC powerlines, the 'increment display' command is executed carefully at the zero-crossing point of the AC voltage using an optotriac coupled with a triac. The pulse length to advance the reel by one step is 100 ms. The mechanism seemed to me so reliable, I didn't bother to use the additional contact these reels have to indicate that the mechanism has advanced correctly. Using 100 ms pulses, I have never noticed the slightest error.

The TMP100 thermal sensor is installed along with its decoupling capacitor on a

As none of these functions requires any great precision, the internal RC clock is adequate and consequently we can dispense with a quartz crystal.

At first start-up, microcontroller performs initialization as follows:

- configures the various ports as inputs or outputs;
- configures the pull-up resistors on its inputs;
- configures the counter (prescaler, interrupt enable),
- recognizes the '00' position on the displays.

Before we go on, let's remember that on a microcontroller with built-in pull-up resistors, once a port has been configured as an input (register DDRD2=0), all we have to do is write a 1 to this port (SBI PORTD,PD2 = Set Bit on port D2) for an internal 20–50 k Ω resistor to be connected within the microcontroller itself between this input and the supply rail. To effectively remove this pullup resistor,

After initialization, our microcontroller reads the temperature sent by the TMP100 sensor via the I²C bus and converts its hex value into binary coded decimal (BCD). The sensor accuracy is 0.5°C or better — more than we need, since we're not going to be displaying the decimals. If it freezes, the display will simply show '00'.

The microcontroller compares each new measurement with the previous reading it has stored, and determines whether the wheels need to go forward or backward. Once the measurement has been made and the display updated, the microcontroller starts an internal counter programmed to 15 min and goes into an infinite loop, from which it can only exit by way of an interrupt. This will come either from the counter reaching the end of the 15 min, or from the analog comparator detecting the power rail dropping below the threshold of about 2.4 V. But don't worry, there's still a safety margin left — the microcontroller will work right down to a voltage of only 1.8 V. If the loop is interrupted by the timer, it's time for the microcontroller to make a new temperature measurement. In the event of

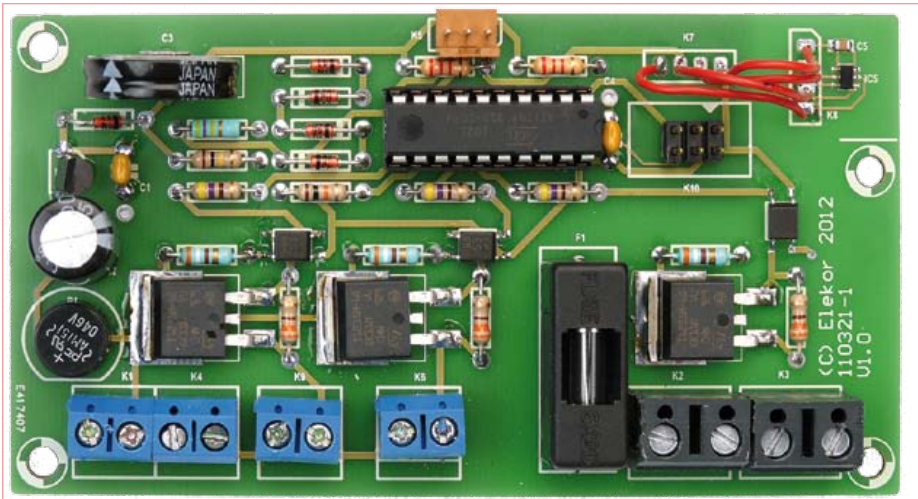

Figure 4. This prototype worked, but has been improved still further; it does not correspond to the final version of the PCB.

a change, a brief activation of the optotriac and triac powers the transformer which supplies the voltage to make the wheels go forward and display the new temperature. During this time, the 1 F capacitor recharges.

If the temperature has dropped, the corresponding reel will have to go through '0'

before the microcontroller can send it the number of pulses corresponding to the figure to be displayed.

Then the AC power is turned off again. Rest! If the loop is interrupted by the analogue comparator, the AC power is enabled for two seconds and recharges the capacitor, then the infinite loop starts again. If for

some reason — for example, the effect of ageing — the capacitor should one day discharge in less than a quarter of an hour, the comparator will take care of it. So thanks to this, the thermometer is never in danger of falling asleep for good.

The microcontroller is programmed via the AVR/ISP connector K10, to which we connect a programmer. I use USBPROG (Elektor October 2007) [2] along with the AVR Studio software from Atmel. Nothing needs to be changed in the configuration of the fuses, the default parameters are:

- Internal RC clock 8 MHz (CKSEL=0100 SUT=10)
- internal clock division by 8 (CKDIV8=0)

My source file and the hex code are on line just waiting to be downloaded [1].

Electrical safety issues

Building this thermometer ought not to pose any problems. However, as the board is connected directly to the 230 V (USA: 115 V) AC powerline, it carries a lethal voltage. Be sure to take all the usual precautions and do not take any chances with safety, particularly with the choice of pushbutton for forcing start-up (marked * on the circuit) or the wiring to it. In fact, since 230 VAC (USA: 115 VAC) rated pushbuttons are not too common components, it's better to opt for an ordinary switch, easier to find in a version with a rating suitable for the intended use here. This is all the more vital since the thermometer is likely to be used outdoors or in conditions where an isolation fault may have fatal consequences. For the wiring, follow the indications on the circuit (Figure 2) and use high-quality screw terminals, especially for K2 and K3, like those in the prototype in Figure 4.

Connecting up the reels

The two connections to the electromagnet are easy to find. Check with an ohmmeter that the coil is in good condition. If it is burnt out, the resistance will be zero or infinity. If the coil is in good condition, it will have a lowish resistance: 7 Ω measured on a Williams coil, around 30 Ω on a Bally.

To find the other connections needed for

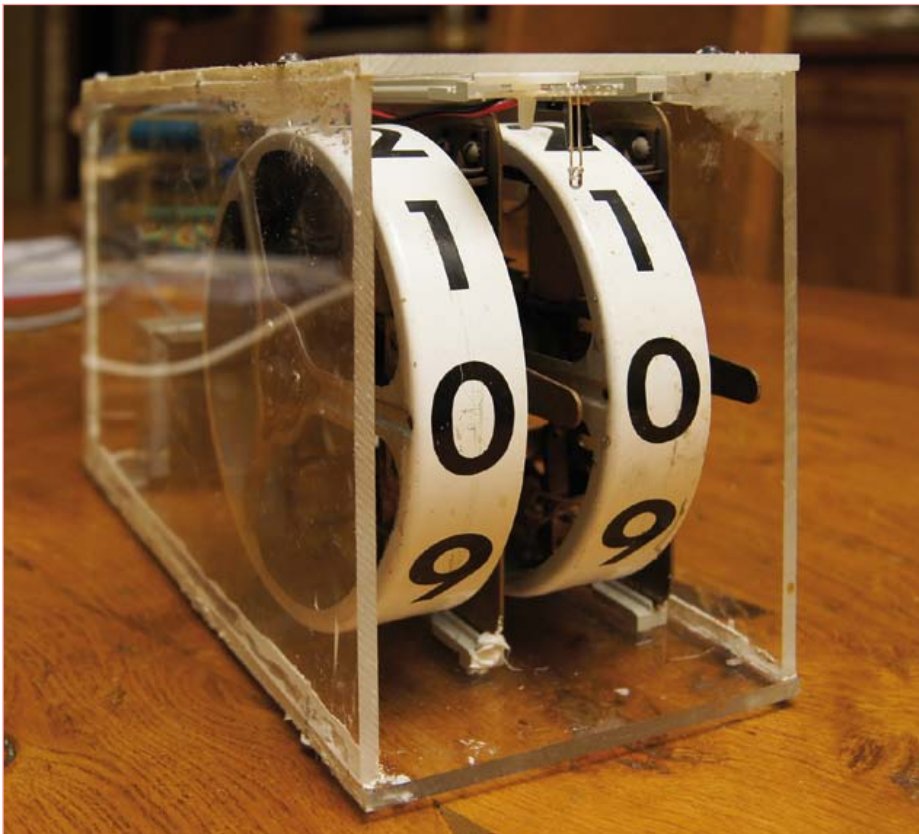

Figure 5. My Gottlieb thermometer in its Perspex case. Each reel is mounted on a card guide.

The author



Ludovic Mézière, 44, a fiddle player and son of a fiddle player, has been constantly playing with a soldering iron ever since the day his father forgot to put it away when he was 7. Obtained a *BTS* [roughly equivalent to an HNC] in electrical engineering in Valenciennes, France in 1988. Has been a technical salesman for professional audiovisual equipment for 20 years with SEMAP (www.semap.fr), and a lecturer on Audiovisual Equipment Technology on a *BTS* course for 12

years. Occasional prototype developer for the CNRS [French national center for scientific research] and cameraman for Rémi Gaillard (www.nimportequi.com). His ambition is to put electronics everywhere it's possible — even if there's no point.

Outdoors, my Gottlieb thermometer built in to the shower wall. The cat and the showerhead give an idea of the scale.

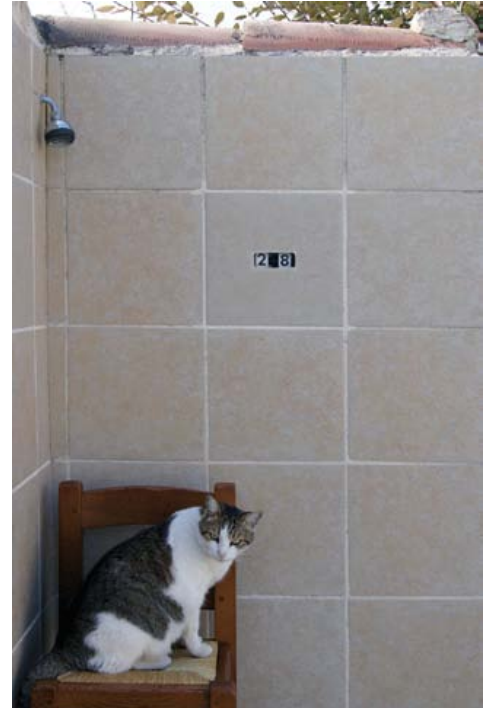

the thermometer to work, the ones for the '0' detector, depending on the type of counter you have, Williams, Bally, or Gottlieb, you'll have to use the continuity tester to identify the connections to the contacts that open when the wheel passes through '0'.

I'd be delighted if readers like my idea and find other applications for it than mine. Don't hesitate to tell the editor about vari-

ants you may think of; if they are interesting, they might get published.

(110673)

Internet Links

- [1] www.elektor.com/110673
 - Sound and light show of the thermometer wheels moving
 - Software for download

[2] www.elektor.com/060224

[3] <http://youtu.be/sKDO19Y0KWg>
<http://youtu.be/sKDO19Y0KWgit>

[4] <http://www.pinrepair.com/gtb/>

Finding these wheels?

If the project tempts you, but you're worried that the wheels may be difficult to find, then you obviously aren't familiar with the resources out there on the Internet. It's easy to find new or second-hand devices in many countries. The destruction of obsolete pinball machines [2] has not been able



to completely wipe out the huge numbers that were mass-produced (a single pinball machine could have as many as 20 reels): spare or salvaged parts can still be found at acceptable prices.

Cleaning the wheels

If the reels you've recovered need cleaning, go about it gently, as the figures are fragile. Don't whatever you do use any cleaning products — at most, mild soap and warm water. If the figures are printed on paper that's been stuck onto the actual reel, it's better not to attempt touching them at all.

If you dismantle the mechanism to clean or admire it, watch out for little springs flying out in all directions! Never lubricate them! The rem-

edy would be worse than the problem. If the counter jitters, either the mechanism is clogged up with dust, or it's been poorly re-fitted. You do sometimes find, after overheating inside the pinball machine, that the solenoid or the sleeve within which the core slides get deformed. Before you do something you might regret, do take the time to do a bit of research on the Internet; using magic formulas like 'EM score reel repair' or 'cleaning', you'll pick up some helpful advice.

RFID Reader Hacks

Reading Mifare (Oyster, ISO 14443) and iClass (ISO 15693) RFID devices

By Martin Ossmann (Germany)

To help familiarize the population with new RFID tag technology, the German Federal Office of IT Security (BSI) more or less gave away several thousand readers in campaigns organized with computer magazines. This article tells you how to modify these readers so they can read MIFARE ISO 14443 cards. If cannot put your hands on one of these giveaway readers, you can use reverse engineering to build the entire reader yourself.



The new German personal ID card contains an ISO 4333 compliant MIFARE/DesFire RFID chip made by NXP. As part of the BSI campaign, the December 2010 issue of *Computer Bild* magazine came with an RFID reader and RFID card as a bonus, at a price of €3.70 (\$ 5). It's hard to imagine a cheaper way to get an RFID reader.

The giveaway reader was the ReinerSCT cyberJack RFID Basis model [1], with a regular selling price (according to the packaging) of €34.90 (\$ 46). In total 1,237,000 of these readers were given out [2], so they will probably be available on eBay for a good while (with prices starting at a couple of euros).

This 'BSI reader' forms the basis for making your own MIFARE ISO 14443 reader. You can either modify an existing BSI reader or use the information obtained from reverse engineering to build the entire reader yourself. These readers use two different types of IC, and we provide circuit diagrams for each type. Finally, we describe a reader with no special components for use with RFID devices compliant with the ISO 15693 standard.

Hack #1: BSI reader with PN512

The internals of the reader, with its very compact circuit board, can be seen in the photo above. **Figure 1** shows the block diagram of the RFID reader. A Cypress USB microcontroller (CY7C64316) handles the control tasks and communication with the USB port. The device is also powered from the USB port, with a voltage regulator (LP3982) providing a 3.3 V supply voltage for the microcontroller and the reader IC.

The reader IC is an NXP PN512, which is suitable for RFID devices compliant with the ISO 14443 standard. The PN512 (data sheet

available at [3]) can also be used as a transceiver for near field communication (NFC).

The reader is useful in two ways. The first is that it gives you a reference design, with the implementation of the matching network between the IC and the transmit coil being especially interesting. The associated circuit diagram is shown in **Figure 2**. An application note with an Excel worksheet for component dimensioning [4] is available from NXP. As you can see from the application note, the design of the reader is closely based on the recommended component values. If you have the reader in question, you can naturally use the existing circuitry to build your own reader. In our case, we unsoldered the existing microcontroller and replaced it with an ATmega88, as shown in **Figure 3**, to make the DIY reader shown in **Figure 4**. The circuitry around the ATmega88 is built on a piece of perforated circuit board connected to the BSI reader board with the PN512 IC. In **Figure 5** you can see how the two boards are joined by thin enamelled copper wires.

If you do not have a BSI reader or do not want to modify it, you can always build your own ISO 14443 reader by combining the circuits shown in Figures 2 and 3 and powering the circuit from a 3.3 V supply. Although the PN512 reader IC can be obtained from various distributors, it is only available in a QFN package and must therefore be reflow soldered.

Software

The commands supported by MIFARE cards and the method used to convey them can be determined from the MIFARE card documentation and the ISO 14443 standard. We wrote some

software that allows some of the basic functions to be tested. The implemented commands and the results obtained from reading the unique ID number (UID) are shown in **Listing 1**.

Hack #2: BSI reader with MFRC523

When we opened up a second BSI reader from the *Computer Bild* giveaway campaign, we discovered that it was fitted with an MFRC523 instead of a PN512. The MFRC523 [5] is largely compatible

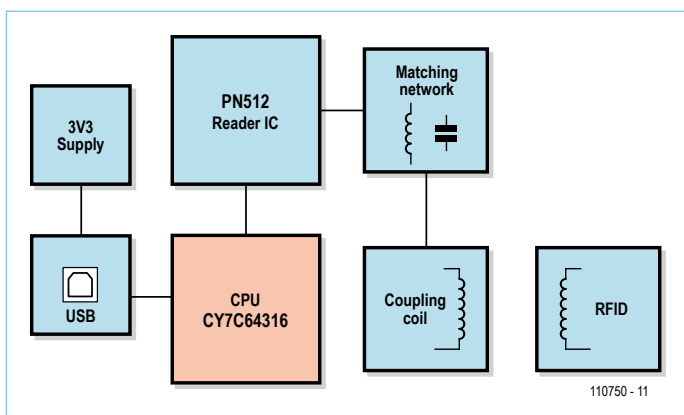

Figure 1. Block diagram of the BSI reader.

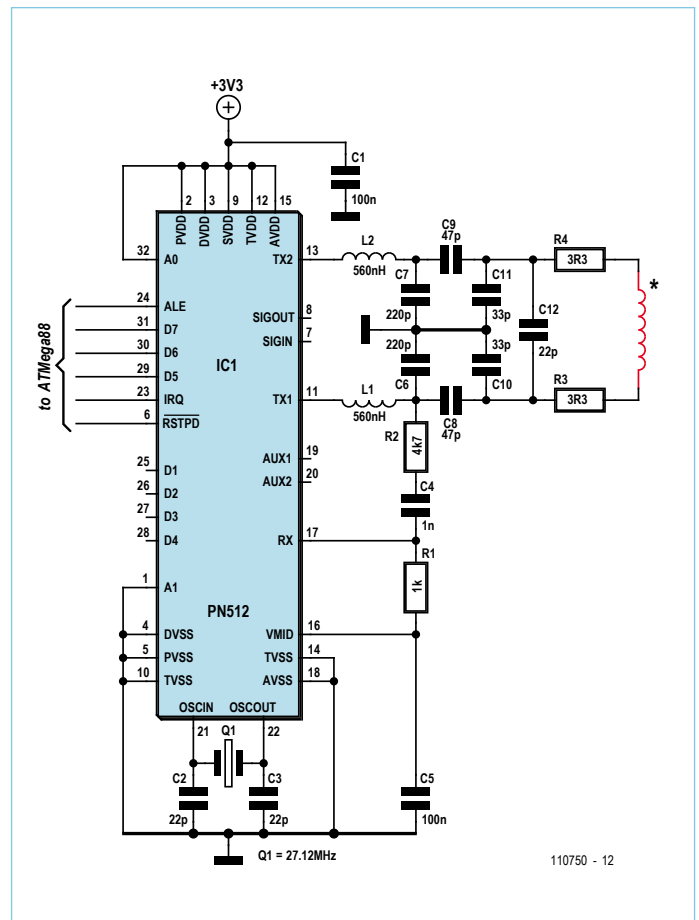

Figure 2. Wiring of the PN512 reader IC.

Listing 1. Log of a MIFARE card reading session

```

Enter command:
W test WRITE Mifare
r test REQA
u test Get UID
d test Get Version DesFire
e test DesFire2
f test DesFire3
m test MIFARE
Get UID
PN512reset Transmitter started.
REQUA: TX:[ 26 ] RX:[ 44 00 ]
COLLISION LEVEL 1 (NoCRC)TX:[ 93 20 ] RX:[ 88 04 D2 3A 64 ]
SELECT LEVEL 1 TX:[ 93 70 88 04 D2 3A 64 ] RX:[ 04 ] SAK=04
COLLISION LEVEL 2 (NoCRC)TX:[ 95 20 ] RX:[ 29 EE 02 80 45 ]
SELECT LEVEL 2 TX:[ 95 70 29 EE 02 80 45 ] RX:[ 00 ] SAK=00
UID complete after level 2
UID= 04 D2 3A 64 29 EE 02 80 45
Read Mifare Card Data
UID= 04 D2 3A 64 29 EE 02 80 45
SELECTED !
ReadData TX:[ 30 00 ] RX:[ 04 D2 3A 64 29 EE 02 80 45 48 00 00 00 00 00 00 ]
ReadData TX:[ 30 04 ] RX:[ FF FF FF FF 00 00 00 00 00 00 00 00 00 00 00 ]
ReadData TX:[ 30 08 ] RX:[ 00 00 00 00 00 00 00 00 00 00 00 00 00 00 00 ]
ReadData TX:[ 30 0C ] RX:[ AA 55 BB 66 00 00 00 00 00 00 00 00 00 00 00 ]
    
```

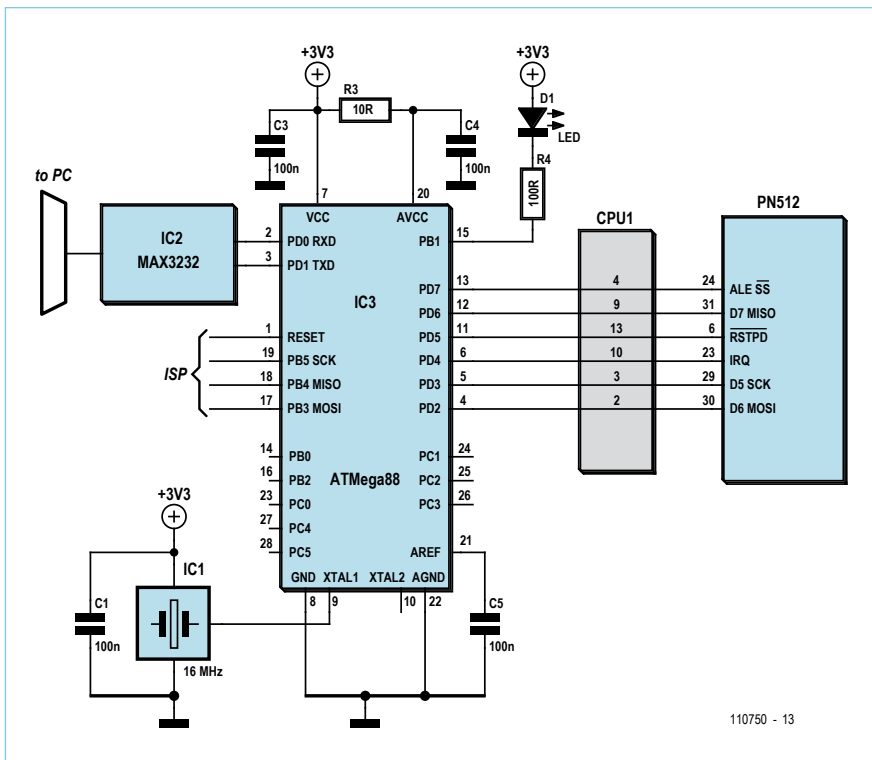

Figure 3. ATmega88 circuit for use with the PN512 circuit.

with the PN512, but a few software changes are necessary. To make experimenting easier, we soldered an MFRC523 on an adapter board. The reader assembled in this manner is shown in **Figure 6**. We made a special effort to simplify the complex coil matching circuit shown in **Figure 2**. As a result, we discovered that an ordinary LC circuit makes an adequate transmit circuit. This yields the considerably simpler circuit for a complete reader shown in **Figure 7**.

The MFRC523 (like the PN512) can output test signals on its test pins (MFIN, MFOUT, AUX1 and AUX2), including internal digital



Figure 4. Prototype with ATmega88 and PN512 reader board.

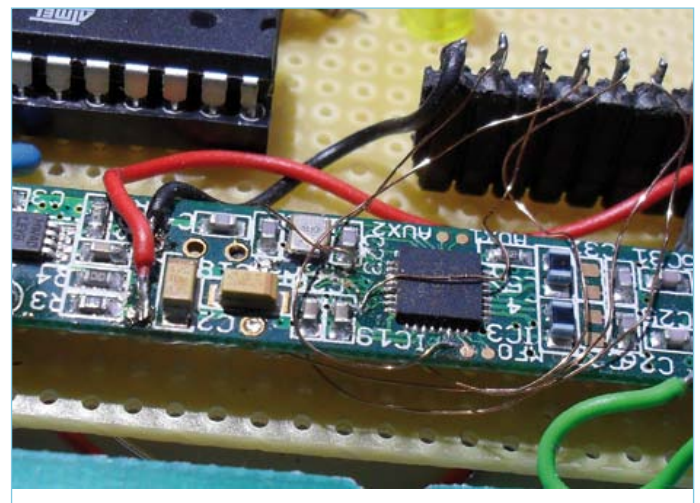

Figure 5. Use fine enameled copper wires for connection to the reader board.

values output as analog values using a 5-bit DAC. Among other things, this can be used to judge the strength and quality of the received signal. This is illustrated by the oscillogram in **Figure 8**. The lower trace shows the analog demodulator signal, and the upper trace shows the received digital signal.

Optimal settings for the numerous parameters of the reader can be determined by analyzing this and other signals.

Hack #3: ISO 15693 RFID devices

Now that we've described the circuits for ISO 14443 RFID devices, it's time for a final DIY circuit for an ISO 15693 RFID device reader, which does not require any special components. ISO 15693 and ISO 14443 are the two most commonly used standards for 13.56 MHz RFID devices. Although these two standards use the same frequency, they involve distinctly different systems.

ISO 14443 defines an interface for contactless smart cards with a maximum range of 10 cm, while ISO 15693 defines an interface for contactless tags with a maximum range of 1.5 m. The circuit diagram of the ISO 15963 reader is shown in **Figure 9**, and the construction of the first prototype is shown in **Figure 10**.

A 13.56 MHz crystal in the circuit provides the clock signal for the ATmega88 microcontroller as well as the HF signal for the transmit coil (L1). The microcontroller can key the transmit signal using gate IC1b in order to send data to the RFID device. The signal is transmitted by the series-resonant circuit L1/C6.

The RFID tag responds using load modulation with a 423.75 kHz subcarrier. **Figure 11** shows the signal at the transmit coil during a high-speed data exchange. The 13.56 MHz carrier can be seen in the middle. The sidebands generated by load modulation are located to the left and the right of the carrier at a spacing of 423.75 kHz. This signal is demodulated by rectifying the coil signal with diodes D1 and D2. Resonant circuit C9/L2 is tuned to 423.75 kHz and filters the received signal. The resulting signal is amplified by T1 and filtered again by L3/C11. To extract the useful data, this 423.75 kHz signal is rectified by diodes D2 and D4 and low-pass filtered by C3, R6 and C14. The resulting signal is applied to the ADC input of the microcontroller.

There it is sampled at a rate of 52.986 kHz ($13.56 \text{ MHz} \div 256$), so that each bit is represented by eight samples. This is achieved by clocking the ADC at a frequency of 847.5 kHz ($13.56 \text{ MHz} \div 16$). This is distinctly higher than the maximum allowable frequency, with the result that we obtain less than 10-bit accuracy, but in our case this does not matter. The software first determines the signal level, then the optimal sampling time (bit synchronization), and finally the start of frame (SOF). After this the useful data can be read.

Alignment

The receiver stage must be aligned in order to achieve a good range. To do this, fit jumper JP2 and then switch the reader on. This causes the 13.56 MHz signal to be pulse-width modulated at 423.75 kHz, using a 3.31 kHz square wave as the baseband modulation signal.

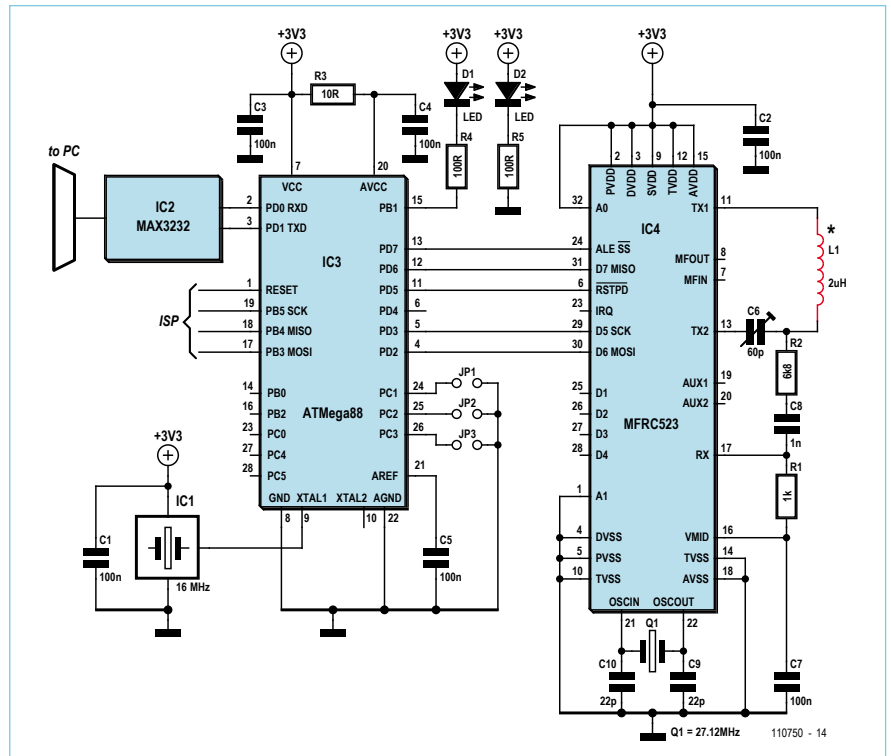

Figure 7. Circuit diagram of the MRFC523 reader.

With this test signal and an oscilloscope, alignment can be performed conveniently in a step by step process. After adjusting R1 to obtain the maximum transmit signal amplitude, you should see a 423 kHz signal on C9, modulated (keyed) by the 3.31 kHz square wave signal. Adjust C9 to maximise the amplitude of this signal. This is best done by replacing C9 with a 500 pF variable capacitor, adjusting it for maximum signal amplitude, and measuring the capacitance value. Of course, you can also use the cut-and-try approach with various values for C9. Once the resonant circuit C9/L2 is aligned, use the oscilloscope to

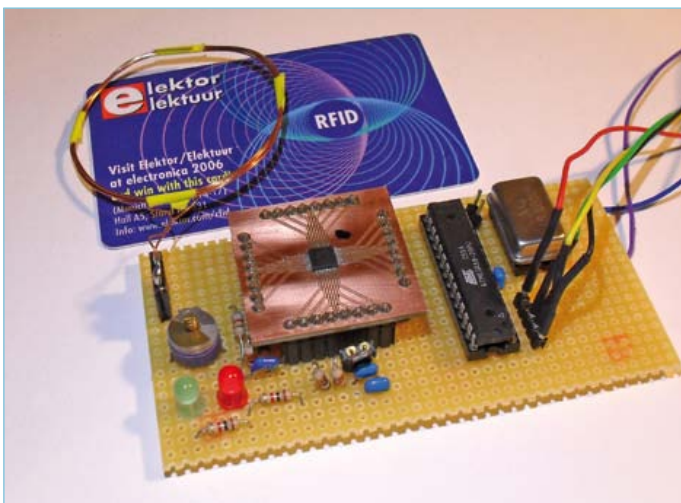

Figure 6. DIY reader with an MFR523 on an adapter board.

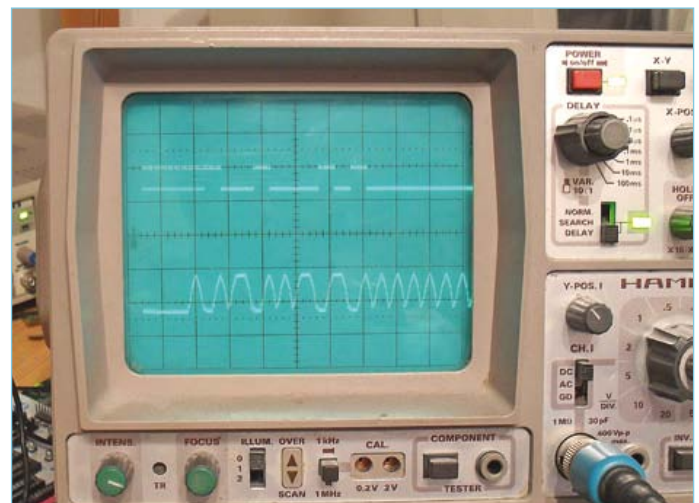

Figure 8. Test signals measured at the MFR523: demodulated analogue signal (bottom) and received digital data (top).

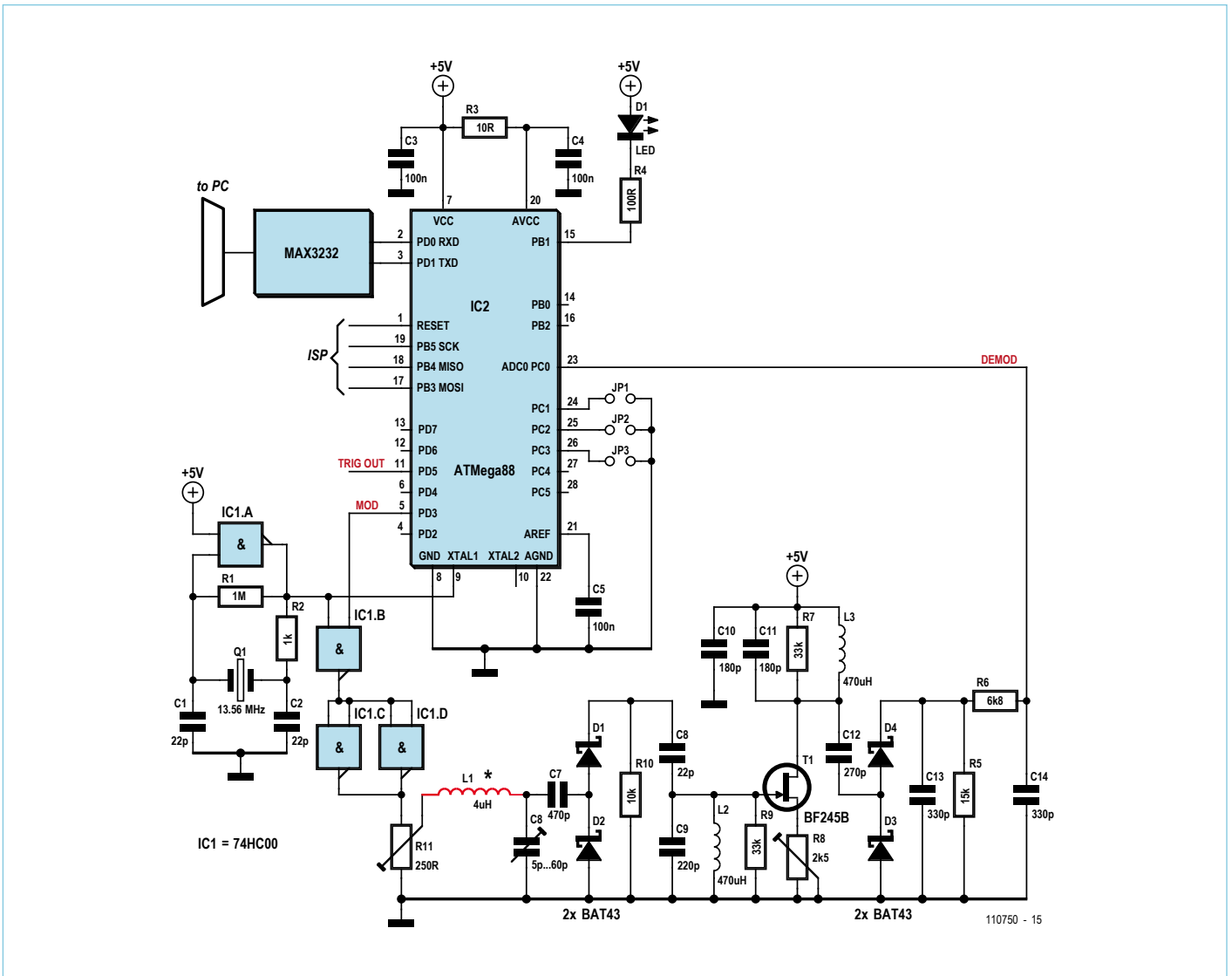

Figure 9. Circuit diagram of the ISO 15693 reader.

Listing 2. Readout from an RFID tag in a book

```
-->READsystemINFO
TX=[00 2B;96 90 ] RX=[00 0F 4E 82 61 45 00 01 04 E0 00 00 1B 03 01;13 10 ]
UID=E00401004561824E
DSFID=00
AFI=00
MEM_BLKs=1B BYTESinBLK=04
-->
DATA=
00 RX=[00 11 01 01 32;F8 41 ] DATA=11 01 01 32 2
01 RX=[00 31 20 54 57;A8 0E ] DATA=31 20 54 57 1 TW
02 RX=[00 51 20 31 34;3C DD ] DATA=51 20 31 34 Q 14
03 RX=[00 35 31 28 32;C2 CE ] DATA=35 31 28 32 51(2
04 RX=[00 29 00 00 18;8E 25 ] DATA=29 00 00 18 )
05 RX=[00 98 44 45 41;24 CA ] DATA=98 44 45 41 DEA
06 RX=[00 39 36 00 00;91 2A ] DATA=39 36 00 00 96
07 RX=[00 00 00 00 00;77 CF ] DATA=00 00 00 00
```

Internet Links

- [1] www.reiner-sct.com/npa/basis.html (ReinerSCT cyberJack RFID Basis product page) (in German only)
- [2] www.heise.de/ct/artikel/ePerso-Alltag-Vom-Foerdern-und-Fordern-Update-1147116.html (in German only)
- [3] www.nxp.com/acrobat_download2/other/identification/124533.pdf (PN512 data sheet)
- [4] www.nxp.com/documents/application_note/AN1445_An1444.zip (AN1445 Antenna design guide for MFRC52x, PN51x, PN53x; AN1444 RF Design Guide plus Excel Calculation)
- [5] www.nxp.com/documents/data_sheet/MFRC523.pdf (MFRC523 data sheet)
- [6] www.waazaa.org/download/fcd-15693-3.pdf (Identification cards - Contactless integrated circuit(s) cards - Vicinity cards Part 3: Anti-collision and transmission protocol)
- [7] www.waazaa.org/download/fcd-15693-2.pdf (ISO/IEC FCD 15693-2 Identification cards - Contactless integrated circuit(s) cards -Vicinity cards -Part 2: Radio frequency power and signal interface)
- [8] www.waazaa.org/download/fcd-14443-2.pdf (ISO/IEC 14443-2 cards, Contactless integrated circuit(s) cards – frequency, power and signal interface)
- [9] www.waazaa.org/download/fcd-14443-3.pdf (ISO/IEC 14443-3 Identification cards Contactless integrated circuit(s) cards - Proximity cards Part 3: Initialization and anticollision)
- [10] www.elektor.com/060221 (Ossmann, Martin: Experimental RFID Reader)
- [11] www.elektor.de/060132-2 (Schalk, Gerhard: The Elektor Electronics RFID Card 13.56 MHz card with MIFARE Ultralight IC) (in German only)
- [12] www.elektor.de/060132-1 (Schalk, Gerhard: Elektor RFID Reader for MIFARE and ISO 14443-A cards) (in German only)
- [13] www.elektor.com/110750 (web page with downloads and links for this article)

measure the signal at the drain lead of T1. Adjust C11 to maximize the signal amplitude at this point. You can view the demodulated signal on C14 ('Demod' test point). Adjust the amplitude by varying the value of R11 until T1 is no longer overdriven. **Figure 12** shows the signal on the drain lead of T1 (upper trace) and the demodulated signal (lower trace) when an RFID card is being read. The amplitude of the demodulated signal is approximately 3 V. Finally, adjust the value of C6 for maximum range.

You can use the software to read various types of data from ISO 15963 cards. For instance, many libraries have fitted RFID tags on their books. **Listing 2** shows the result of analyzing the data from a book with the signature 'TWQ 1451(2)'. As you can see, the signature is stored in the data area as plain text.

All sorts of experiments can be performed using the circuits described here. The software is available for free download [13], so you can also use it (either as is or modified) for your own projects. (110750)

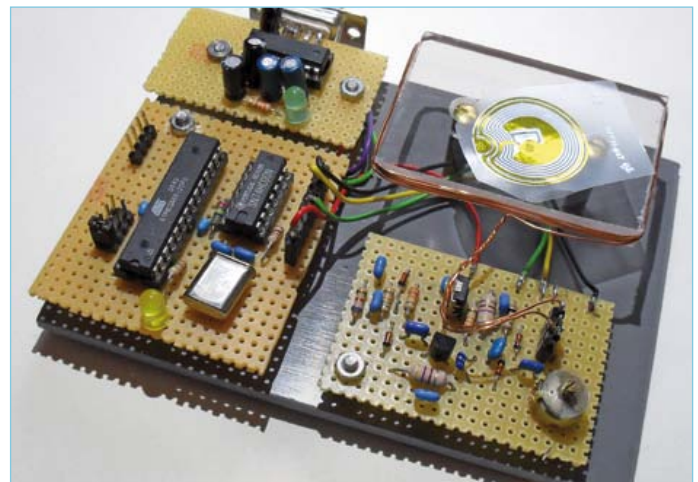

Figure 10. Prototype of the ISO 15693 reader.

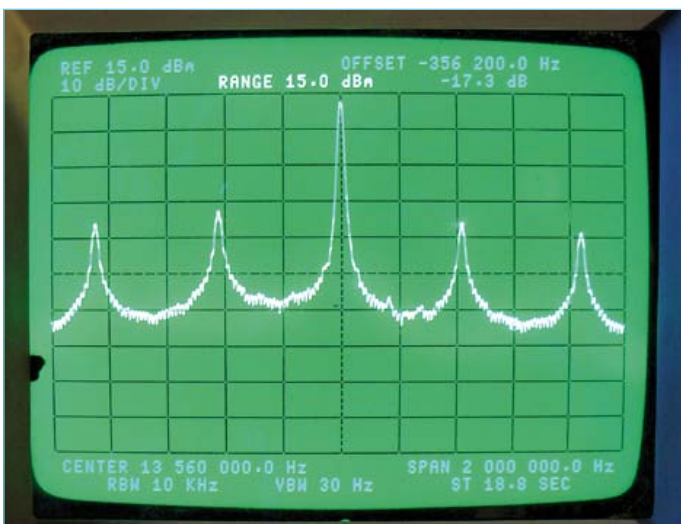

Figure 11. Spectrum during data exchange.

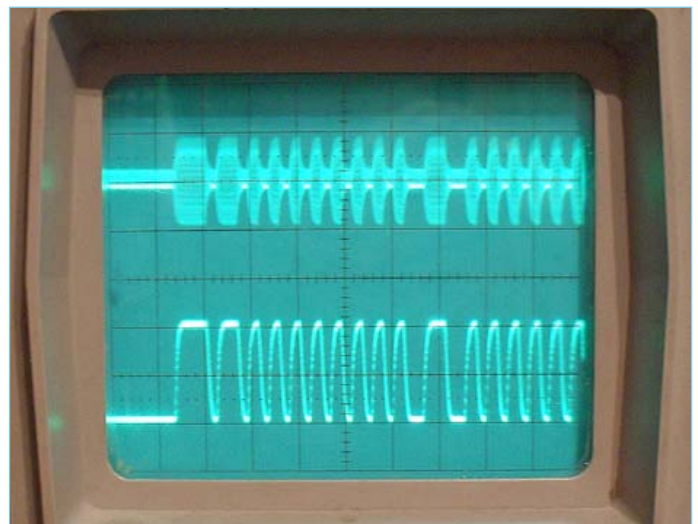

Figure 12. Received 432 kHz signal and demodulated signal.

Electronics for Starters (4)

Constant current sources

Designing electronic circuits usually starts with studying the data sheets of complex integrated circuits. However, you shouldn't lose sight of the fact that ICs incorporate a variety of basic circuits, which in many cases you can also build with discrete transistors. Besides being educational, that's a lot of fun!

By Burkhard Kainka (Germany)

In the previous installments of this course we have already dealt with the current gain, input characteristics and saturation behavior of bipolar transistors. Now we expand our field of view to include field-effect transistors. The various properties of transistors can be utilized in a wide variety of circuits. In each case the interesting question is how you should design the circuit so it will reliably do what it is suppose to do. Of course, you also need to know the limits of what the circuit can handle.

A constant current source

Sometimes you need a constant current with the least possible dependence on supply voltage stability. For example, a LED driven by a constant current source will always have the same brightness, even when the battery voltage drops. In theory all you need for this is a single transistor in a common-emitter circuit. If you drive the transistor with a constant base current, the collector current will be nearly constant

regardless of the voltage between the collector and the emitter. This can be seen from the output characteristics of a typical NPN transistor (**Figure 1**).

Figure 2 shows a constant current source built around a single transistor. It can be used with a wide range of supply voltages and with different numbers of LEDs wired in series. The collector current is nearly constant. In technical terms, we say that the constant current source has a large differential internal resistance R_i , where $R_i = dU/dI$. In this circuit the constant base current is provided by a separate voltage source.

You could also build a voltage regulator that generates a stable voltage (e.g. 3 V) from an unstable supply voltage. However, you can't easily obtain a precisely defined current with this circuit. In particular, the tolerance range of the current gain makes it impossible to predict the exact collector current.

Using a BF245 JFET

A similarly imprecise constant current source can be built with a junction field-effect transistor (JFET), such as the type

BF245. As explained in the inset, with this type of transistor you apply a negative voltage to the gate to obtain the desired current. **Figure 3** shows the output characteristics of the BF245B with various values of gate-source voltage V_{GS} . The drain current I_D is fairly constant as long as the drain-source voltage V_{DS} is not too low. The range of variation of the BF245's characteristics is similar to that of the BC547, which is why the BF245 also has three gain classes (A, B and C). The BF245B has a specified drain current of approximately 10 mA with zero gate voltage.

The simple 10 mA current source shown in **Figure 4** is good enough for practical use, as long as you can live with an actual current somewhere between 8 mA and 12 mA. In any case, it's hard to beat this circuit for simplicity, although it should be noted that the current is somewhat dependent on the drain-source voltage because the internal resistance is not especially high at low drain-source voltages.

What you need here is some sort of closed-loop control that keeps the current con-

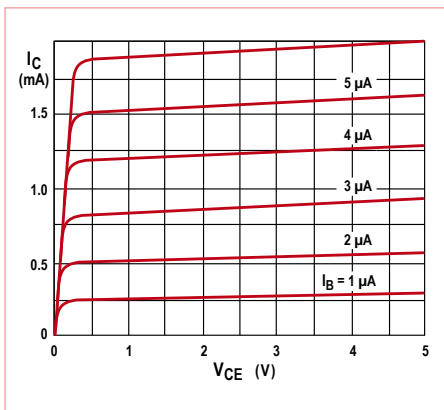

Figure 1. BC547B output characteristics.

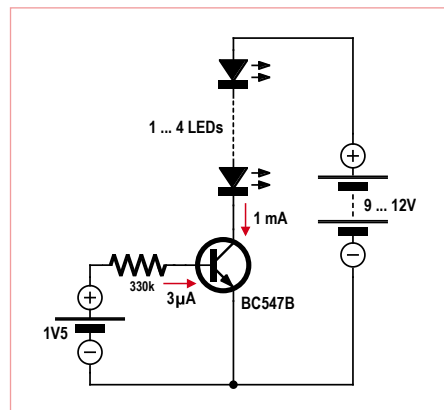

Figure 2. Constant current.

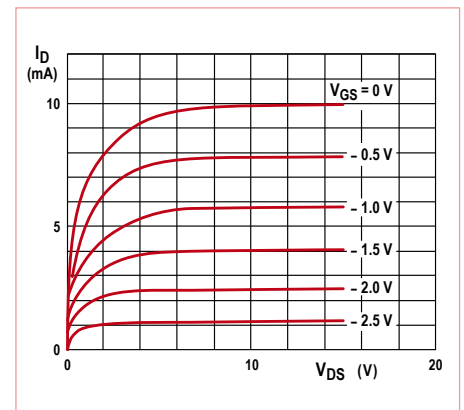
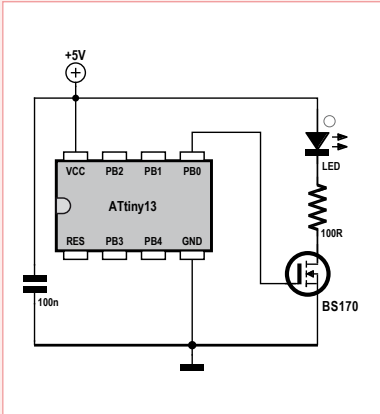

Figure 3. BF245B output characteristics (source: Philips).

Soft LED blinker



This simple ATtiny13 application implements an LED driver that causes the LED brightness to slowly rise and fall repeatedly. Of course, you could achieve the same effect with a controlled current source, but standard practice in the microcontroller world is exactly the opposite: everything is either hard on or hard off — absolutely

binary. In order to achieve variable brightness in this situation, you can use pulse width modulation (PWM). This involves switching an output alternately on and off in rapid sequence to generate a pulse train that is so fast that you can't see the individual pulses. Here the LED brightness depends on the ratio of the On and Off times. The ATtiny13 uses its internal Timer 1 for PWM output; the PWM signal appears on the PB0 pin. Here we use a VMOS transistor type BS170 as a power driver. As you can see, the base resistor needed with a bipolar transistor is not required here.

```
$regfile = „attiny13.dat“
$crystal = 1200000
Dim I As Byte
Dim D As Integer

Config Portb = Output
Config Timer0 = Pwm , Prescale = 1 , Compare
A Pwm = Clear Down

Do
  For I = 40 To 215
    If I < 128 Then
      D = I
      D = D * D
    End If
    If I > 127 Then
      D = 255 - I
      D = D * D
    End If
    D = D / 64
    Pwm0a = D
    Waitms 60
  Next I
  Waitms 800
Loop
End
```

stant. A simple way to implement this is to add a source resistor, as shown in **Figure 5**. This arrangement is often used to generate the gate bias voltage 'automatically'. It also improves the stability of the output current by increasing the internal resistance. This works as follows: if the output current increases, the voltage drop over the source resistor also increases, causing the gate voltage to be more negative relative to the source voltage. This acts to reduce the drain current. This circuit effectively generates a simple form of negative

feedback. You can also set the value of the current within wide limits by selecting the value of the resistor. If you want to have a bit more than 1 mA, simply use a resistor with a lower value.

Using a bipolar transistor

The circuit shown in **Figure 6** is a simple constant current source built around an NPN transistor, which converts a constant voltage into a constant current. A Zener diode at the input stabilizes the base volt-

age at approximately 2.7 V, due to the effect of its steep characteristic curve. As the base-emitter voltage is always approximately 0.6 V, the voltage over the emitter resistor is approximately 2.1 V. This resistor therefore determines the emitter current. The collector current is only slightly less than the emitter current, which also includes the much smaller base current. With negative feedback provided by the emitter resistor, this circuit is almost directly equivalent to the FET circuit shown in Figure 5. The only difference is that here

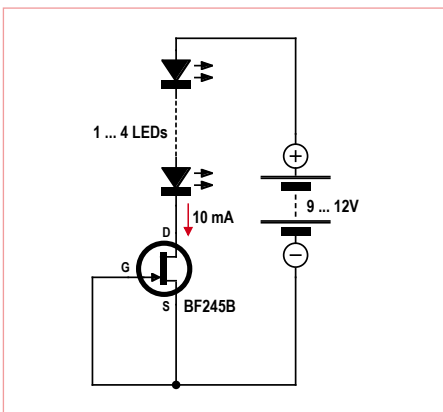

Figure 4. A simple JFET constant current source.

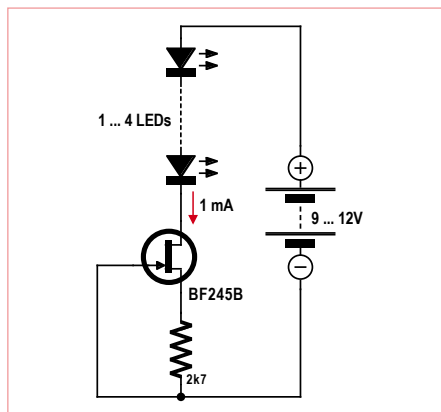

Figure 5. Using a source resistor to set the current.

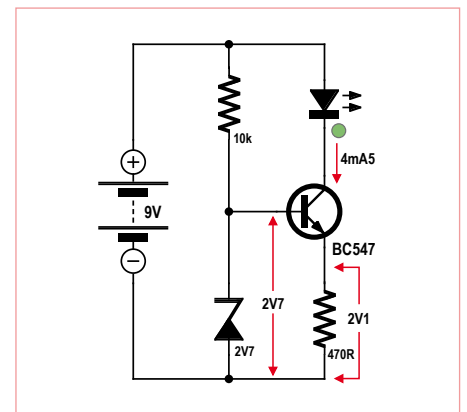

Figure 6. A constant current source using a Zener diode.

Field-effect transistors

The two main classes of transistors are bipolar transistors and field-effect transistors (FETs). A field-effect transistor consists of a small piece of semiconductor material with only one type of doping (either p or n). It has an isolated gate electrode, which alters the number of charge carriers in the region between the source and the drain when a voltage is applied to the gate. This changes the conductivity in this region, which is called the channel. Depending on the voltage on the gate, the concentration of charge carriers in the channel is either depleted or enriched. The advantage of field-effect transistors is that they do not need a current to control the output current, but instead a voltage.

The gate (G), source (S) and drain (D) terminals of a FET correspond to the base (B), emitter (E) and collector (C) terminals of a bipolar transistor. There are numerous types of field-effect transistors. Along with the junction FET, which has an isolating diode junction between the gate and the channel, there is another type (MOSFET) that has a metallic oxide isolating layer. Like bipolar transistors, MOSFETs are available in two polarities, called n-type MOSFETs and p-type MOSFETs according to the polarity of the source and drain voltages. MOSFETs are basic building blocks of many types of integrated circuits, especially computer ICs. Complementary n-type and p-type MOSFETs are often used in the same IC, which is called CMOS technology. Power MOSFETs are usually fabricated with a vertical structure and accordingly designated VMOS. The following table provides a comparative overview of the specifications of a number of typical VMOS transistors:

| Type | N/P channel | I_{max} | U_{max} | P_{max} | R_{DS-ON} | C_{GS} | C_{DG} |
|-------|-------------|-----------|-----------|-----------|-------------|----------|----------|
| BS107 | N | 150 mA | 200 V | 0.8 W | 28 Ω | 50 pF | 4 pF |
| BS170 | N | 175 mA | 60 V | 0.8 W | 5 Ω | 60 pF | 5 pF |
| BS250 | P | 180 mA | 45 V | 0.8 W | 14 Ω | 60 pF | 5 pF |

Junction field-effect transistors use a semiconductor junction to isolate the gate from body of the transistor. This means that the gate voltage must always be negative, as otherwise the GS junction would be biased into conduction. JFETs are classified as depletion-mode FETs because charge carriers are normally present in the channel when no gate voltage is applied, and they can be depleted by applying a voltage to the gate. If an increasingly negative voltage is applied to the gate, the channel between the source and the drain is gradually pinched off until the transistor stops conducting. Incidentally, this behavior corresponds exactly to that of a vacuum valve.

A typical example of this type of FET is the BF245, which is primarily intended to be used in high-frequency applications. It has a typical transconductance of 5 mA/V, which means that changing the gate voltage by 1 V causes the drain current to change by 5 mA. The BF245B has a typical cutoff voltage (zero drain current) of approximately -4 V and a drain current of approximately 10 mA with zero gate voltage.

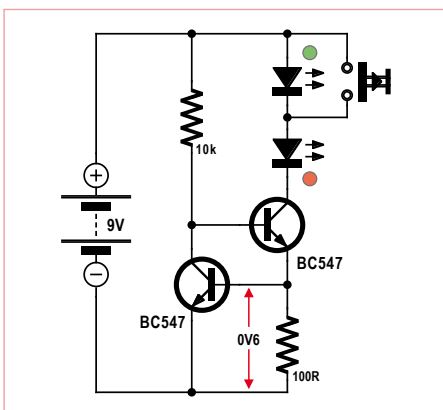
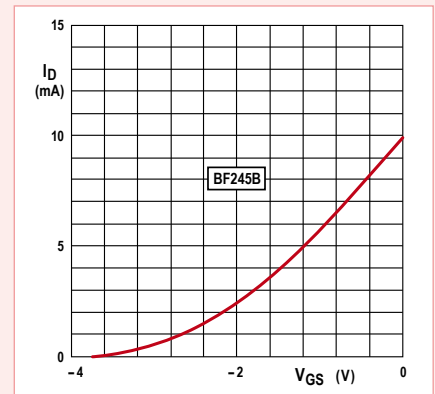
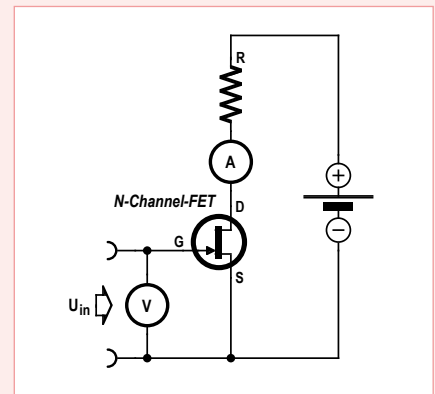
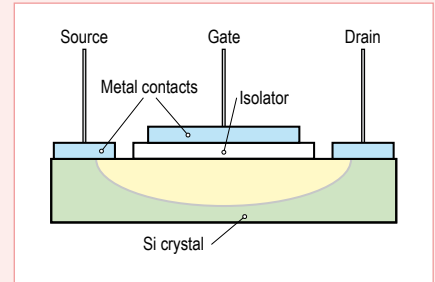

you need a positive voltage source for the base, which makes the component count a bit higher. However, the good news is that the BC547 is cheaper and it provides better regulation in this circuit. The negative feedback is so effective with this circuit that you can scarcely measure any

Figure 7. A constant current source with two transistors.

difference if you first fit a BC547A, then a BC547B and finally a BC547C. In other words, you can use whatever version you happen to have in your parts tray. Another tip: if you don't have a suitable Zener diode handy, you can replace it with a forward-biased LED and still obtain good results.

Test the results for yourself with a new battery and with a nearly discharged battery, or with an adjustable power supply. The LED

Quiz

You want to power three white 1-watt power LEDs from a 12 V lead-acid battery. The LEDs have a specified forward voltage of 3.4 V and a specified operating current of 350 mA. You want to use a constant current source to provide the correct current. The circuit uses a BD135 power transistor, which can be attached to a heat sink if necessary.

The battery voltage can rise as high as 14 V during charging and drop as low as 11 V during discharge. The circuit should operate properly within this range. The current source should supply a current close to 350 mA, but in no case more than 350 mA. At this relatively high current, you can assume that the base-emitter voltage is approximately 0.7 V.

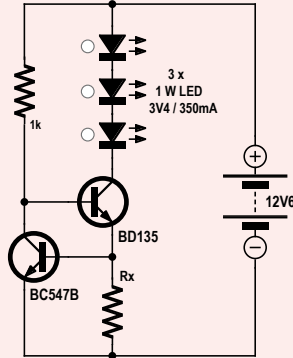

1) You have three choices available for resistor R_x . Which one would you use?

- A) 100 Ω
- B) 47 Ω
- C) 22 Ω

2) You measure a battery voltage of exactly 12.6 V, and the voltage over each of the LEDs is 3.4 V. How high is the efficiency of the circuit?

- D) 81%
- E) 52%
- F) 99%

3) You measure a battery voltage of exactly 14 V, and the voltage over each of the LEDs is 3.4 V. If the current is 350 mA, how much power must the BD135 dissipate?

- G) Approximately 0.5 W
- H) Approximately 1 W
- I) Approximately 3 W

If you send us the correct answers, you have a chance of winning a **Minty Geek Electronics 101 Kit**.

Send you answer code (composed of a series of three letters corresponding to your selected answers) by e-mail to basics@elektor.com.

Please enter only the answer code in the Subject line of your email.

The deadline for sending answers is April 30, 2012.

All decisions are final. Employees of the publishing companies forming part of the Elektor International Media group of companies and their family member are not eligible to participate.

The correct solution code for the quiz in the February 2012 edition is 'CDH'.

Here are the explanations:

- 1) Answer 'C' is correct. When you touch the contacts, the (small) capacitor charges relatively quickly. The two transistors conduct and light up the LED. Due to the high gain of the Darlington circuit, the base resistance could be even greater than 10 M Ω , but resistors with such high values are difficult to obtain. The capacitor discharges very slowly, with a time constant of 10 s. However, the LED continues to emit light for much longer than 10 s.
- 2) Both transistors are in the B class and have similar current gains in the range of 200 to 450. Their current gains multiply, so the effective current gain lies in the range of approximately 40,000 to approximately 200,000. The figure of 100,000 is close to the middle of this range, so answer 'D' is correct.
- 3) The current gain with two NPN transistors would lie in the same range, and the junction voltages at saturation are the same: the base-emitter voltage is approximately 0.6 V, and the collector-emitter voltage is approximately 0.1 V. However, there is a difference at the input. With two transistors of the same type, you need twice the usual base-emitter voltage (i.e. approximately 1.2 V) to cause the transistors to conduct. Only one base-emitter voltage (approximately 0.6 V) is necessary with the complementary circuit. 'H' is therefore the correct answer.

brightness should remain nearly the same as long as the battery isn't completely flat, and an ammeter should show a constant collector current.

Another commonly used type of constant current source uses a second transistor in place of the LED. In this case the reference voltage is effectively the base-emitter voltage (around 0.6 V) of the left-hand transistor in **Figure 7**. If the voltage drop over the

emitter resistor is too high, the left-hand transistor reduces the base current until everything is as it should be.

The current provided by a constant current source is not only independent of supply voltage variations, but also independent of the voltage drop over the load. You can use the switch in the circuit shown in **Figure 7** to drive either one or two LEDs with the constant current source. The same cur-

rent flows in both cases. This current source is quite practical and provides a current of approximately 6 mA.

(120004)

The RL78 Microcontroller

An MCU family for low-power applications

When Renesas took over NEC they acquired a large range of electronic devices, including the popular 78K series of 8 and 16-bit microcontrollers. Not long after the acquisition the RL78 MCU family was announced, decidedly targeted at low power applications.

By Clemens Valens (Elektor UK/US Editorial)

The low power 8/16 bit microcontroller (MCU) market is a bit of a war zone with several MCU manufacturers proposing “the industry’s lowest power solution”. In a YouTube video [1] TI boasts a best active figure of 160 $\mu\text{A}/\text{MIPS}$ for their MSP430 family; in application note AN1267 [2] Microchip claims 110 μA at “1 MHz Run” for their PIC16LF72X, and Renesas announces 70 μA at “1 MHz normal operation” on their RL78 product website [3]. The absence of justification on just how these figures were obtained makes comparing them rather futile. But then, you don’t really have to, because, as most low power developers will know from experience, if you don’t get the hardware and software design right, you will never achieve the promised 20-year battery life-time no matter how low the MCU’s active, sleep or standby current may be. In this article we will take a closer look at Renesas’ quickly expanding RL78 family to see what they have on offer that may help you create a successful low power design.

The RL78 family

The RL78 family of 16-bit MCUs currently has two branches called ‘generic’ and ‘application specific’, but a third one named ‘display’ is due to arrive soon. The generic branch contains the subfamilies G12, G13 and G14 — all based on the 78K core — and the G14 based on the R8C core. In the application specific branch we find the 1A and F12. I am not sure about their core origins



as these products are still very new and documentation is not available at the time of writing. No big deal, from now on it’s the new RL78 core for all devices, hence I can concentrate on the G13 for which I got this nice evaluation board (see inset).

RL78/G13

This family comes in a large number of versions (I counted 182), with devices having between 20 and 128 pins (note that the parts themselves are labeled R5F10xxx). Besides the package type the devices differ in terms of flash memory size (program and data) and RAM. Program flash memory starts at 16 KB and currently tops at 512 KB while data flash sizes can be 0, 4 or 8 KB, and RAM is 2 KB for the small devices up to 32 KB for the big ones.

Let’s have a look at the chip architecture in **Figure 1**. The CPU is 16-bit, but the internal memory architecture is 8-bit. Its 32 general-purpose registers are organized in four

banks of eight and can be used as 8-bit or 16-bit registers. The memory-mapped special function registers (SFRs) that control the on-chip peripherals can be addressed at bit level, at byte level or as 16-bit registers, depending on the register. A second set of SFRs, the extended or 2nd SFRs is available too, but they need longer instructions to be accessed.

For those who need to squeeze the maximum out of MCU performance it may be interesting to know that the CPU offers a short addressing mode allowing you to access a page of 256 bytes with a minimum amount of code.

The maximum clock frequency of the processor is 32 MHz but the hardware user’s manual of almost 1100 pages interestingly also boasts about the ultra low speed capabilities of the processor as it can run from a clock as low as 32.768 kHz.

The RL78 core features 15 I/O ports, most of which are 8-bit wide. Port 13 is 2-bit wide and ports 10 and 15 are 7-bit wide. The port pins that are actually available depend on the device. Inputs and outputs are highly configurable. Inputs can be analog, CMOS or TTL; outputs can be CMOS or N-channel open drain. Pull-up resistors are available too. The exact configuration possibilities depend on the port pin, so be sure to consult the datasheet. Because of the many configuration options it is possible to use the MCU in multi voltage systems without level-shifting circuitry except for the occasional external pullup resistor. The chip can be powered from 1.6 V to 5.5 V, the core itself runs from 1.8 V supplied by an internal voltage regulator.

Time management

Several options are available for the MCU clock. When clock precision is not too important the MCU can be run from its internal clock – up to 32 MHz – otherwise it is possible to connect an external quartz crystal, resonator or oscillator. An internal low speed clock (15 kHz) is also available, but not for the CPU, it's for the watchdog timer (WDT), the real-time clock (RTC) and the interval timer only.

The RL78's timers are flexible and offer many functions. Depending on the pin count of the device you can have up to sixteen 16-bit timers, grouped in two arrays of eight. Each timer (called a 'channel') can function as interval timer, square wave generator, event counter, frequency divider, pulse interval timer, pulse duration timer and delay counter. For even more possibilities, timers can be combined to create monostable multivibrators and PWM. This way up to seven PWM signals can be generated from one master timer. If you need more timers and resolution is of lesser importance you can split some 16-bit timers in two 8-bit timers (this not possible with all timers). Timer 7 of array 0 is extra special as it features LIN network support (see below).

Besides date and time keeping and alarm management the real-time clock (RTC) also provides constant period interrupts at 2 Hz and 1 Hz and also every minute, hour, day or month. A 1 Hz output is available on devices with 40 or more pins. For extra precision the RTC offers a correction register for fine tuning the 32.768 kHz clock. Unsurprisingly, the RTC continues to work when the MCU is stopped. Now that I mentioned Stop mode, a special interval timer peripheral allows the MCU to be woken up at periodic intervals. This timer is also used for the A/D converter's 'snooze mode', on which more later on. With a clock frequency of 32,768 Hz the lowest interval rate is 8 Hz (0.125 ms).

Yet another time related peripheral on the RL78 is the buzzer controller (not available on 20-pin devices). This is a clock output aimed at IR comms carrier generation, to clock other chips in a system or to produce sound through a passive buzzer. A gate bit allows modulation of this output in such a way that pulses always have the same width.

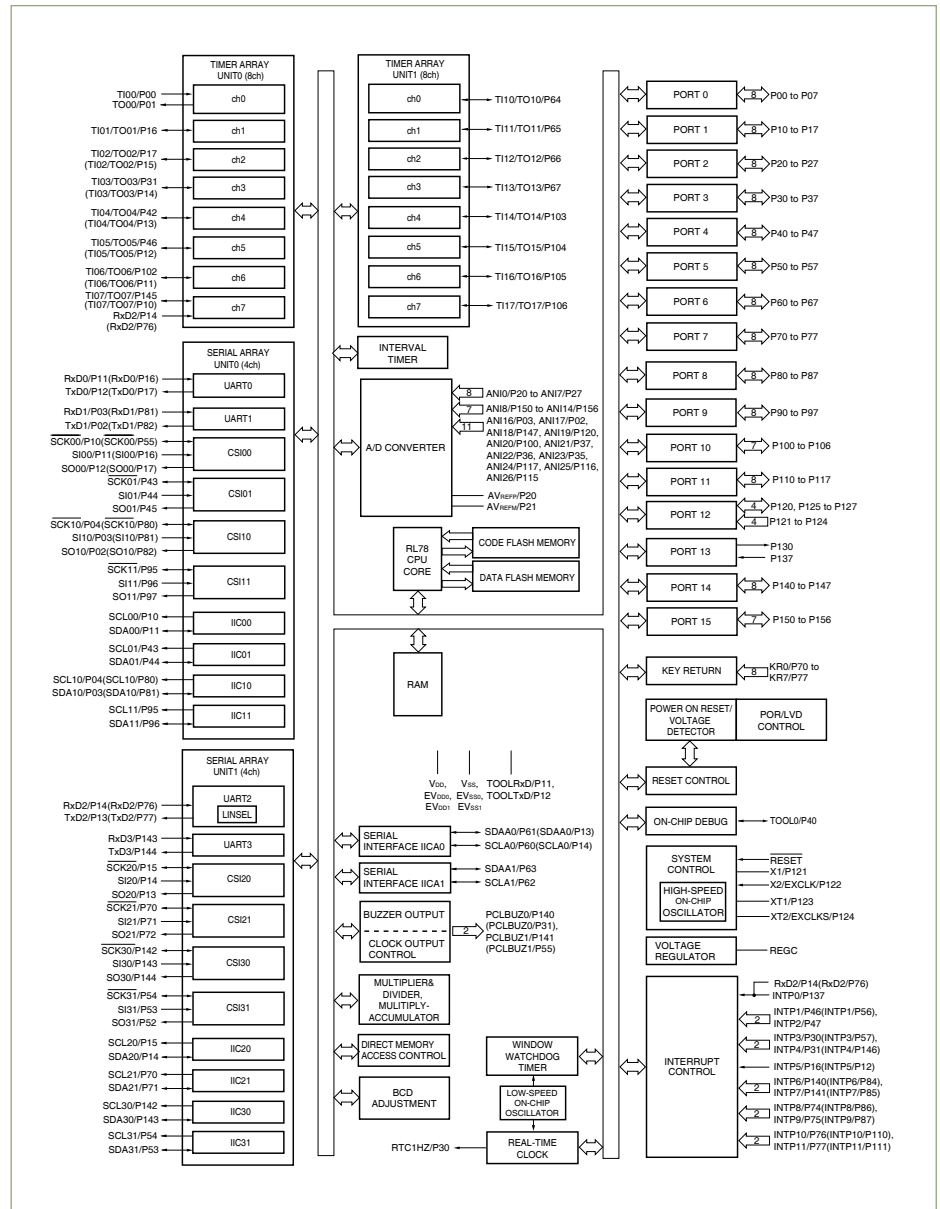

Figure 1. Block diagram of the 128-pin RL78/G13 devices. Devices with fewer pins have less and/or smaller blocks.

Finally, a watchdog timer completes the timing peripherals. It has a special window mode limiting the time frame during which you are allowed to reset the watch-

dog to a certain fraction of the watchdog interval (50 %, 75 % or 100 %). Resetting the watchdog counter outside the window results in a reset. The window is open

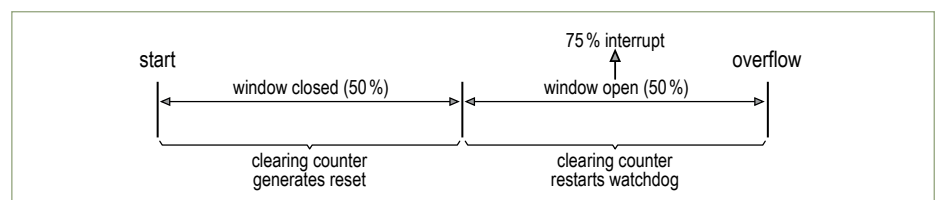

Figure 2. Trying to reset the watchdog counter when the window is closed results in an internal reset signal being generated. An interrupt can be used to flag that the window is open.

in the second part of the interval. An interrupt can be generated when the watchdog timer reaches 75 % of its time-out value, i.e. when the watchdog reset window is known to be open in all cases. **Figure 2** illustrates the mechanism.

A/D converter

The analog-to-digital converter (ADC) is of the 10-bit successive approximation type and can have up to 26 inputs. Several triggering options are provided in terms of hardware and software, where hardware triggering means triggering by a timer module (timer channel 1 end of count or capture, interval timer or RTC). The time it takes to do a conversion depends partly on the triggering mode. When input stabilization is not too much of an issue (when you don't switch inputs for instance) you can achieve conversion times of just over 2 μ s.

Two registers allow comparing the ADC's output to maximum and minimum values, producing an interrupt when the new value is either out of bounds or within bounds. This function is also available in Snooze mode. In this mode the processor itself is stopped and consumes very little power, but ADC conversions continue under control of the hardware trigger. When a conversion triggers an ADC interrupt the processor can then wake up from Snooze mode and resume normal operation.

Communications

The RL78 features multifunction serial units. The devices with 25 pins or less have one such unit, the others have two. Only serial unit 2 provides LIN bus support. A serial unit can function in asynchronous UART mode, in Synchronous CSI mode (3-wire bus with clock, data in & data out signals, Master & Slave mode supported) and in Simplified mode, meaning Master-only I²C mode. Again, depending on the device, you can have up to four UARTs or eight CSI and/or simplified I²C ports. Of

course a mix is possible too. Full I²C is possible with the specialized I²C unit. UART0 and UART2, CSI00 and CSI20 provide Snooze mode functionality similar to the A/D converter. In Snooze mode these ports can be made to wake up on the arrival of incoming data without waking up the CPU. If the received data is interesting enough, it is possible to wake up the CPU too. Local Interconnect Network (LIN) communications are possible with UART2 together with timer 7 of array 0. The LIN bus is a

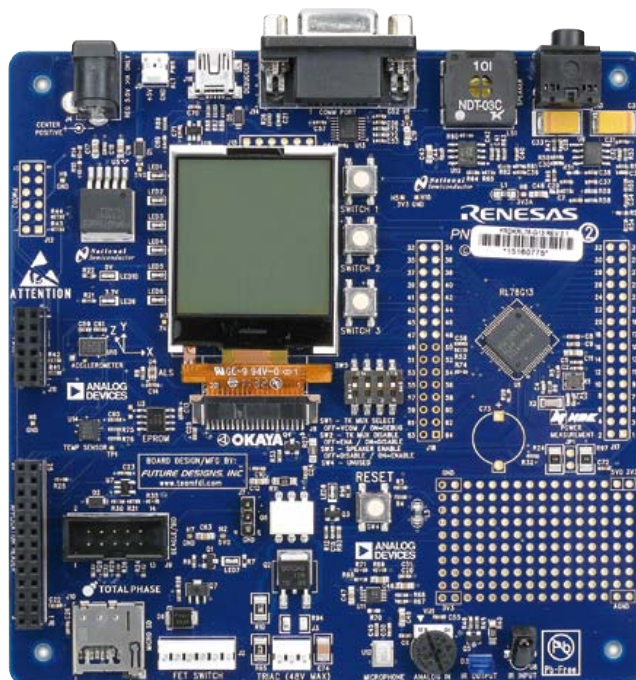

cheap alternative to the CAN bus in automotive systems to control simple devices like switches, sensors and actuators. LIN only uses one wire and is rather low speed (max. 20 kbit/s). The timer takes care of the LIN synchronization issues and the UART performs the (de)serialization of the data. Full blown I²C communication is possible with the specialized I²C peripheral IICA. The 80-pin and more devices have two channels, the others only one. Communication speeds up to 20 MHz are allowed, making I²C 'fast mode' (3.5 MHz) and 'fast mode plus' (10 MHz) possible. This module is capable of waking up the CPU from Stop mode.

Math accelerators

The hardware multiplier and divider module intended for filtering and FFT functions is highly interesting. This module is capable of doing 16 x 16 bits signed and unsigned multiplications and divisions producing 32-bit results. It can also do 16 x 16 bits multiply-accumulate. We're talking about a module here, not an instruction, meaning you have to load the operands yourself in special registers and get the result from yet another. The multiplication itself is done in one clock cycle, a division takes 16. The accumulate operation adds another cycle.

Another special math function is the Binary Coded Decimals (BCD) correction register that allows you to easily transform binary calculation results into BCD results.

Direct Memory Access

To speed up data transport without loading the CPU, the RL78 core features Direct Memory Access (DMA, up to four channels). DMA transfers up to 1024 words of data (8 or 16 bit) to and from SFRs and RAM, and they can be started by a range of interrupts (ADC, serial, timer). Although DMA transfers are performed in parallel with normal CPU operation, it does slow down the CPU. For time critical situations you can put a DMA transfer on hold for a number of clock cycles and let the CPU finish its job first.

Interrupts

Interrupts are pretty standard on the RL78, and many sources are available. The 'key interrupt' function on the other hand is less common. It provides up to eight (depending on the device, you guessed it) key or pushbutton inputs that are OR-ed together to generate an interrupt on a key press (active Low).

Operating modes and security

Besides the Stop and Snooze modes already mentioned the RL78 also provides a Halt mode. In this mode the CPU is stopped, but the clocks keep running making rapid

The Renesas Demonstration Kit (RDK) for RL78

The square development board (5.1 x 5.1") for the RL78/G13 MCU comes loaded with many useful peripherals like a graphical LCD with SPI interface, a stereo audio/PWM output, a MEMS microphone, a miniature loudspeaker with its own amplifier, three pushbuttons, some LEDs, communication interfaces like IR, RS-232, I²C & SPI, a micro SD card slot, a 512 KB serial EEPROM, a 3-axis I²C accelerometer, I²C temperature and ambient light sensors, extension connectors and more. Less common are the two power switching outputs, one controlled by a MOSFET (2 A, 60 VDC, $R_{DSon} = 78 \text{ m}\Omega$) and the other by a TRIAC (max. 48 VAC_{RMS}). The RDK has an on-board Renesas TK debugger/programmer supported by the IAR compiler (kick-start edition included in the kit).

The extension headers come in several flavors: two are compatible with Digilent's SPI-based PMOD standard, one is an application header accepting add-on modules like the Wi-Fi modules from Red-Pine and Gainspan and finally two expansion headers allow direct access to certain MCU pins. For the owners of a Beagle I²C or SPI protocol analyzer (manufactured by Total Phase) it will be interesting to know that a compatible port is available on the board providing easy access to the I²C and SPI busses.

The board can be powered over USB or from an external 5 VDC regulated power supply, but be careful: there are no overvoltage or under-voltage protections. A supercap can be mounted for battery-operated applications.

resuming possible. In Stop mode the clocks are stopped too, reducing power consumption more than in Halt mode. Snooze mode is like Stop mode, but with one or more peripherals in a snoozing state, ready to wake up when something interesting happens. Interrupts can be used to wake up from Snooze, Stop or Halt mode. A reset usually works too.

Reset, by the way, can originate from seven sources, three of which are related to safety functions: illegal instruction, RAM parity and illegal memory access. Two others involve the power supply: Power-On Reset (POR) and Low Voltage Detection (LVD). All these reset options are needed to conform to the IEC 60730 (*Automatic electrical controls for household and similar use*) and IEC 61508 (*Functional Safety of Electrical/Electronic/Programmable Electronic Safety-related Systems*) safety standards. The RL78 being compliant in this respect, it also implements flash memory CRC checking, protections to prevent RAM and SFRs to be modified when the CPU stops functioning, an oscillator frequency detection circuit and an ADC self-test function.

The hardware used for the flash memory CRC check is also available as a general-

purpose CRC module for user programs. It implements the standard CCITT CRC-16 polynomial ($X^{16} + X^{12} + X^5 + 1$).

The RAM guard function protects only up to 512 bytes, so be careful where you put your sensitive data.

Flash & fuses

Those familiar with the fuse bytes of PIC and AVR processors will be happy to know that the RL78 contains four of these configuring the watchdog timer settings, low voltage detection, flash memory modes, clock frequencies and debugging modes.

Flash memory is divided in two parts, program memory and data memory, and it can be programmed in-circuit over a serial interface. A boot partition is available also. This partition employs a kind of ping-pong mechanism called 'boot swapping' to ensure that a valid bootloader is always programmed into the boot partition so that even power failures during bootloader programming will not harm the boot partition. A flash window function protects the memory against parts of it being reprogrammed unintentionally.

Further information

www.renesasrulz.com/community/demoboards/rdkrl78g13



Sounding off

This concludes our initial tour of the Renesas' RL78 core. It's obvious that the RL78 offers many interesting peripherals, all combined in a flexible low-power optimized design. Thanks to the integrated oscillator and other functions an RL78 MCU can be used with very little external hardware, enabling cheap and compact designs. Having mastered its Snooze mode and with a fair command of low-power designing, you can confidently use this MCU family in applications like battery-operated metering. I am sure though you can think of something more surprising.

(120183)

Internet Links & References

- [1] www.youtube.com/watch?v=eG4xDCq17jc
- [2] <http://ww1.microchip.com/downloads/en/AppNotes/01267a.pdf>
- [3] www.renesas.com/pr/mcu/rl78/index.html

Component Tips

By Raymond Vermeulen (Elektor Labs)

Isolation

This month we're talking about isolation. In recent times I've come across this topic in several projects I have been working on. One of the first questions you have to ask yourself is: "What is the best place in a system for the isolation barrier?". Try to find a location in the circuit where the isolator will have the minimum influence. You will then quickly realize that this is generally at the inputs and outputs of the system. That is also the place where the ICs described below can be used. But why would you want to isolate? This can be done for several reasons: to prevent ground-loop noise, to connect systems with different ground potentials together or to protect sensitive equipment from faults in systems to which they are connected. The most dangerous situation is when the AC line voltage suddenly appears on the ground of the system. If I'm interpreting the data-sheets for these two ICs correctly then these should easily cope with that.

(120224)

ADM2587E

During the design phase of the ElektorBus RS485 Switch Board discussed elsewhere in this issue, we considered whether we should galvanically isolate the bus lines from the rest of the electronics. In the end we didn't do this, but that doesn't make this chip any less interesting. In addition to the RS-485 bus it is also possible to connect an RS-422 bus. Remarkably, the data lines are isolated using tiny 'on-chip' transformers instead of opto-couplers. The maximum data rate is 500 kb/s, which would make an isolated DMX possible, for example. Another interesting feature of this chip is the integrated isolated power supply, and all this for a reasonable price and surface area. One disadvantage however is that this power supply is very inefficient; because of the small dimensions the operating frequency has to be very high (180 MHz!). This could be a potential source of EMI problems with a poor board layout. The manufacturer has an Application Note (AN-0971) that describes this problem. But the most important, of course, are its isolation qualities. High DC offsets are permitted for short durations, 2500 VDC for 1 minute and continuously up to 560 VDC. ESD protection on the data lines is also quite good, rated at ± 15 kV.

| Parameter | Condition | Value |
|---|--------------------------|-----------------------|
| Data Rate | Maximum | 500 Kbps |
| Nodes | Maximum connected | 256 |
| Rated Dielectric insulation voltage | 1 minute duration | 2500 V |
| Maximum continuous working voltage (AC) | 50 year minimum lifetime | 424 V _{peak} |

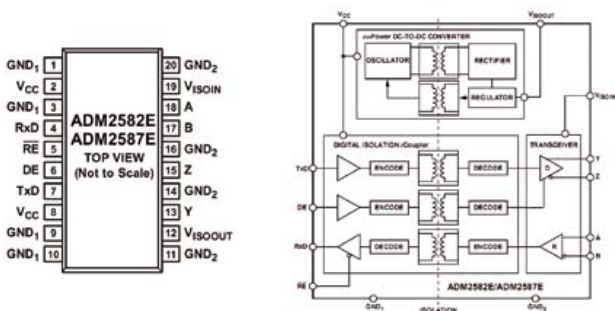

Internet link: www.analog.com/static/imported-files/data_sheets/ADM2582E_2587E.pdf

ADuM3160

When it comes to isolation of the USB bus lines, there aren't a lot of ICs to choose from. This IC and its more expensive brother, the ADuM4160, are the only one I could find to offer USB isolation. It may be the reason all commercially available isolators are fitted with one of these chips. During a new design, or a redesign, the designer can drop such an IC directly into the circuit. In contrast to the ADM2587E alongside, these ICs do not have an integrated isolated power supply, so this will have to be added separately. Both sides can be powered from 3.3 V or 5 V, both sides contain an integrated LDO. One disadvantage of this IC is that it does not comply fully with the USB specifications. Normally the data rate on a USB line can change automatically. In this case a hardware choice has to be made between 1.5 Mb/s and 12 Mb/s. However I don't think that's a problem for most applications. All is well when it comes to isolation, an AC voltage of 565 V can be sustained for 50 years. Higher voltages are tolerated for a much shorter period, like 2500 V for only 1 minute.

| Parameter | Condition | Value |
|---|--------------------------|-----------------------|
| Min. Data Rate | SPD, SPU = L | 1,5 Mbps |
| Max. Data Rate | SPD, SPU = H | 12 Mbps |
| Maximum continuous working voltage (AC) | 50 year minimum lifetime | 565 V _{peak} |
| Rated Dielectric insulation voltage | 1 minute duration | 2500 V |

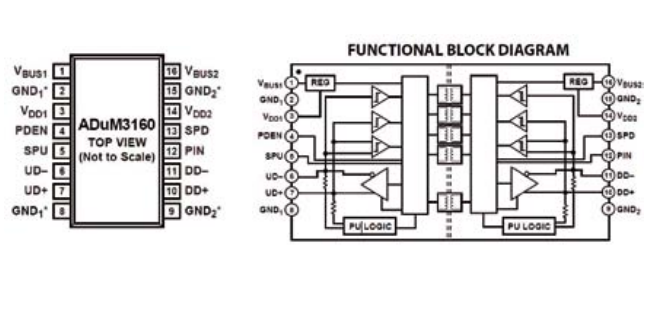

Internet link: www.analog.com/static/imported-files/data_sheets/ADuM3160.pdf

Elektor RF & Microwave Toolbox

➔ for Android

The RF & Microwave Toolbox contains 34 calculation and conversion tools for RF, microwave and electronics in general. Whether you are an RF professional, radio-amateur, astronomer or hobbyist, this app puts some of the most important tools right at your fingertips. Literally!

Highlights:

- Amplifier cascade (NF, Gain, P1 db, OIP2, OIP3)
- Field intensity and power density converter (W/m², V/m, A/m, Tesla, Gauss, dBm, W)
- PCB Trace calculator (impedance/dimensions)
- PI and T attenuator
- Antenna temperature (Kelvin)
- EMC (EIRP, ERP, dBμV/m)
- Filter Design (Butterworth, Chebyshev, prototype)
- And much more

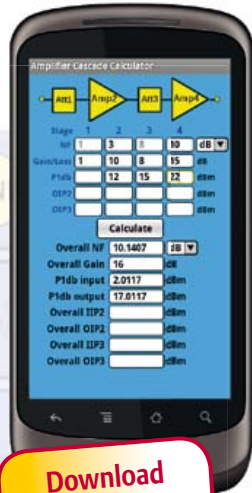

Download your app now!



Further information at

www.elektor.com/rf-app





FREE Stencil

with every prototype order



EAGLE order button

pcb-pool.com/download-button

20% off! on your first order

Call Tyler: 1 707 447 7744
sales@pcb-pool.us

PCB-POOL® is a registered trademark of **Beta** LAYOUT

www.pcb-pool.com

eweekly

elektor newsletter

Take out a free subscription to Elektor Weekly

Do you want to stay up to date with electronics and information technology? Always looking for useful hints, tips and interesting offers? Subscribe now to Elektor Weekly, the free Elektor Newsletter.

Your benefits:

- The latest news on electronics in your own mailbox each Friday
- Free access to the News Archive on the Elektor website
- You're authorized to post replies and new topics in our forum



Register today on www.elektor.com/newsletter

USB Add USB to your next project. It's easier than you might think!

DLP-USB1232H: USB 2.0 UART/FIFO

HIGH-SPEED
480Mb/s



Only \$28.95!

- Multipurpose: 7 interfaces
- Royalty-free, robust USB drivers
- No in-depth knowledge of USB required
- Standard 18-pin DIP interface; 0.6x1.26-inch footprint

DLP-IO8-G

8-Channel Data Acquisition

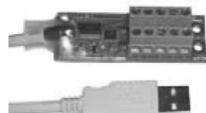

Only \$29.95!

DLP-IOR4

4-Channel Relay Cable

DLP-TH1b

Temp/Humidity Cable

DLP-RFID1

HF RFID Reader/Writer

DLP-FPGA

USB-to-Xilinx FPGA Module

- 8 I/Os: Digital I/O
- Analog In
- Temperature
- USB Port Powered
- Single-Byte Commands



www.dlpdesign.com

Reliability

By Gerard Fonte (USA)

Arguably, the biggest difference between a hobbyist-designed project and a commercial product is reliability. Hobbyists don't mind if they have to tinker with it from time to time. After all, we like to tinker. But you don't want to tinker every morning to get your car started, or with the toaster, or with your computer. A reliable product is tinker free.

Analyze This

It cannot be overstated that reliability comes from attention to detail. It's the small things that count. You need to take the time to examine all the aspects of any circuit the first time you design it. After the first time, you will know the important areas to look at. But for the first time, you have to consider every part.

My favorite example is the lowly unregulated, power supply. It's just a transformer, bridge rectifier and filter capacitor. Simple, right? If you choose a 24 volt transformer, then a 35 volt capacitor should be fine, shouldn't it? That's a 50% safety margin. The answer is a resounding, NO!

The transformer is rated in RMS voltage, under load; not peak voltage. The peak is 1.414 times the RMS or about 34 volts. Add about 10% for being unloaded and the actual DC voltage at the filter capacitor is over 37 volts. Capacitor confetti, anyone? And if you plan on using a common 3-terminal voltage regulator (LM78xx type) you should know that they have a maximum input of 35 volts (although there is some variation from manufacturer to manufacturer). Another failure in waiting.

You choose to use half-amp rectifiers because your design only draws 0.1 amps. To be extra safe you use a 2-amp transformer and high value capacitors you have on hand. There shouldn't be a problem here, should there? Yes there is. During turn-on the capacitors act as dead shorts across the transformer. During a short, the transformer's output is only limited by the resistance of the winding, which is typically about 0.5 ohms. In theory, a surge current of about 75 amps could occur (37 volts into 0.5 ohms). In practice it's quite complicated, but the usually accepted value (not guaranteed!) is 10 times the transformer rating. In this case, that's 20 amps (10×2 amps). Most silicon rectifiers are robust and can take very short surges up to 30 times their continuous rating or 15 amps here (30×0.5 amps). A surge of 20 amps into a 15-amp-surge rectifier won't go. Also, the length of the surge depends upon the size of the capacitors. The bigger the capacitors, the longer the surge. So, the reliability of the rectifier may depend more on the transformer and capacitor rather than the down-stream circuit.

It's important to see the critical need for proper circuit analysis for every part under every condition. You can't guess at reliability. You have to be sure.

More for Your Money

Hobbyists (like me) are perpetually short on cash. So, we tend to look for the minimum requirements for a part. Sometimes this isn't

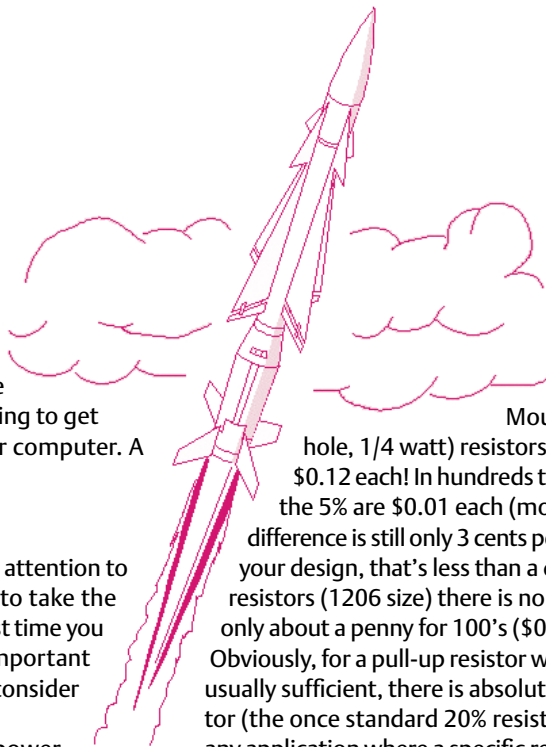

the best choice. For example, why use a 1% resistor when a 5% resistor will work? The reason is that 1% resistors are so commonplace now that the price is virtually the same. My

Mouser catalog shows 1% (through-hole, 1/4 watt) resistors at \$0.06 each and 5% resistors at \$0.12 each! In hundreds the 1% resistors are \$0.04 each and the 5% are \$0.01 each (more sensible). But in hundreds, the difference is still only 3 cents per resistor. If you use 30 resistors in your design, that's less than a dollar increase. For surface mount resistors (1206 size) there is no difference for singles (\$0.05) and only about a penny for 100's (\$0.02 vs. \$0.032).

Obviously, for a pull-up resistor where any value from 1K to 100K is usually sufficient, there is absolutely no requirement for a 1% resistor (the once standard 20% resistors don't exist anymore). But for any application where a specific resistance is needed (voltage dividers, gain-setting, etc) the question is reversed. Why shouldn't you use a 1% resistor? Additionally, 1% resistors usually have better temperature stability.

It's a similar story for generic power rectifiers (1N400x). Different manufacturers have different basic prices for the diodes (I saw \$0.05 to \$0.15 each). But within the series (1N4001 to 1N4007) there was often no difference in price. The 1N4007 has a PIV (Peak Inverse Voltage) of 1000 volts where the 1N4001 has a PIV of only 50 volts. According to my Motorola Data Book, every other specification is the same. So, there is simply no reason not to buy the better diodes. You are getting much more for your money.

Look Before You Leap

These examples show the need to know what your design requires and what parts are available. Using parts that exceed the operational needs of the circuit will improve performance and reliability. And we've seen that this can be achieved with a minimum increase in cost or no increase at all.

The point is not to focus only on your needs when looking for parts. You might be able to find parts that are better than what you need for a small difference in price. And there are trade-offs. Which is more important in your design, the actual value of the capacitor or its working voltage? Will the lower on-resistance of the power MOSFET switch reduce heat build-up? Is it worth spending an extra dollar for a relay with 20 amp contacts versus 10 amp contacts? Does it make sense to use a solid-state relay, instead?

There is clearly much, much more to reliability than I can possibly cover here. There are many fine books on the subject. But fundamentally, designing reliable products is the result of a mind-set. It's not enough to make it work, it has to work well. And in order to do this, you have to consider every aspect of your design as well as the practical considerations of the parts that go into that design. After all (one of my favorites), engineering is just common sense with attention to detail.

(120236)

Philips EL3581 Dictaphone (ca. 1960)

“Did you get that, Miss Money Penny?”



By Jan Buiting (Elektor UK/US Editor)

First seen in the mid 1950s, dictating machines were the pinnacle of office automation. In the sales pitch of the period, these machines “contribute substantially to general efficiency in the busy office by reducing costly time spent by doctors, attorneys, managing directors, editors in chief and other high ranging officials, commercial or government, on producing written communication with the outside world.” With a dictation machine in the office, the contemporary MD/CEO would record his message alone in his room or cubicle, speaking his corrections, erasing and rewinding the tape and then discretely hand the cassette to his secretary for her to work out into a document. Or so they thought it should work. Earlier systems like the Gray AudoGraph used flexible records to store recordings [1]. The Dutch generally known an industrious people keen on getting the most money from as little time as possible, it is surprising to note that their only electronics giant, the Philips company (US: Norelco), was late to introduce a dictating machine. But when they did, the concept became an important product line that would last well into the 1990s – in different guises of course and eventually called ‘memocorder’. Today, we have smartphones and no secretaries anymore. Cigars and typewriters also seem out of fashion.

Apart from its obvious use in *The Office*, the dictating machine was claimed as great for “recording telephone calls, recording and/or preparing momentous speeches, recording interviews, pronunciation drills (in language classes), as well as recording weather bulletins and stock exchange information”.

The Philips EL3581/22 kit shown here was probably introduced around 1960 – despite its clear 1950s looks and two-tone color scheme (plus oxblood red for the controls). I have no evidence of it being a mid-1950s product. In good Philips tradition the machines got a coined name: *Dictaphone*. The original EL3581 (pictured here) has a rotating tape dial under a clear plastic, slightly magnifying bell jar with a control on top you could turn to reset the counter to 0. The later more frequently seen EL3581R Dictaphone had a mundane thumbwheel-operated tape counter, besides an additional telephone pickup input and a less vivid color scheme.

My machine is a gem in every way and attracts affectionate responses from young and old. It is in pristine condition complete with a mass of accessories like a footswitch, stethoscope earphones, a zip-up carrying bag not unfit for the 2013 Prada Collection, a typewriter support panel, an unused notepad, a microphone/loudspeaker with desktop support, and two tape cassettes in their original boxes. I found the ‘luxury’ accessories like the footswitch, typewriter support panel and the earphones in new condition after

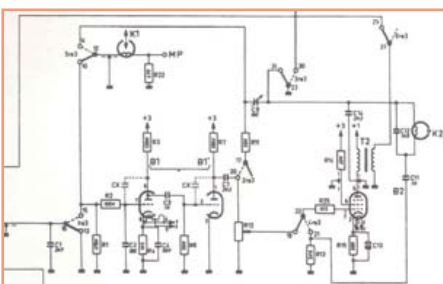

~~Secretaries~~ Administrative Professionals and Executive Admins Day
April 25, ~~1952~~ 2012
Consider: Flowers, Cards, Gift Certificates, Lunch, Candies, Assorted Gift Baskets

In a way, dictating machines replaced three scenarios that were common in a pre-1950 corporate head office:

- MD/CEO smoking a cigar, slowly pacing up and down the room and giving straight dictation to a patient and diligent secretary with a stenographic notepad on her lap. Putting figures to efficiency, 50 words and 2 cigars per hour were not uncommon.
- MD/CEO scrawling notes on bits of paper, rummaging the trash bin for lost scraps. Cutting, pasting, rewording, panicking, doodling, finally stapling his scribbling at 5:58 pm and grabbing his coat. In overtime, an extremely patient secretary assembles the text fragments in the right order, corrects glaring mistakes, tones down aggressive sections and generally formats the lot into a professional yet polite letter she drops in the mail on her way home.
- MD/CEO behind his desk, helpless without his secretary, she having taken a day off. No official letters sent for a full day! No doubt causing serious decline in turnover, profit, assets, S&P Ratings and cigar consumption.

For the difference between a secretary and a stenographer, watch Jean in the fantastic Coronet Instructional Film from 1947 [3], especially at 09:20.



50 years. Unusually, the unit came with an envelope full of documents, including a repair note and associated invoice showing one of the rubber drive belts had been replaced (at fabulous cost) by Philips' Service Center in 1966. I also found a user manual for the EL3581R kindly but erroneously sent by Philips (at moderate cost) because Sales was "unable to determine the customer's exact version of the equipment" (sorry chaps, it was the old EL3581; "I shall advise you by return letter shortly.").

The documents to hand indicate the unit was registered to a School Medical Service in Holland probably aiming to speed up medical reporting and forms creation and filing on thousands of hapless school children in the early 1960s. Hands up everyone with horrible recollections of these examinations! However neither the doctors, nurses, nor any of the medical secretaries up in Stadskanaal seem to have made much use of the Dictaphone pictured here, except someone sending it off for repair once.

I decided to test the Dictaphone, silently hoping to hear dry medical observations on the tapes supplied. The equipment contains two tubes so I powered it up ever so gently using my variable transformer, slowly raising the AC line voltage over a day or so to enable the electrolytic capacitors to reform and not explode or squirt their nasty content through the top vents. The unit turned out to work okay, except the tape rewind dish did not turn. Oh well, I could still

play tapes, record and fast-forward; and fast-reverse simply by flipping the cassette over and fast-forward. The machine appears to have two identical green knobs on the front but in reality the left one is a finger support.

The unit employs 3.5-inch (8 cm) tape reels in transparent plastic cassettes. The cassettes can be opened by removing a single metal clamp, allowing reels to be exchanged. The quarter inch (6.35 mm) magnetic tape runs at 4.75 cm/s (1 7/8 ips) and I guess with the maximum length of tape you can record up to about 20 minutes of precious information. Philips proudly advertised the cassettes and associated cardboard boxes as an efficient means of conveying important business information by post including airmail to remote destinations. Like Canada, Limbricht or Barra ("a wild & desolate place")!

My initial impression when starting the first tape was the EL95 (6DL5) tube being in some self-oscillating frenzy, but on listening carefully it turned out to be someone playing a transverse flute badly. When the cats had returned to the room, a father's voice deftly said "That was Wendy on the flute, now little Anton continues on his alt saxophone". About five minutes on on the tape, the children joined in an as yet unidentified musical piece. In 1965, none of my friends' or classmates' parents could afford flute or saxophone lessons for their offspring, let alone own such instruments legally. So it might have been the good doctor himself having permanently



borrowed the precious Dictaphone for pure scientific use at home. According to the manual the Dictaphone is ever so easy to use by the skilled secretary. There's truth in that if the secretary is female, most men I reckon are befuddled by the controls and the excruciatingly slow method of getting coherent sentences and information in the right order. "Best left to Moneypenny that, 007!"

I intend to restore my Dictaphone to full working order by replacing the broken rubber belt in the rewind mechanism. The mechanical construction of these machines is second to none and the belt should be easy to replace once I get the extremely sticky black goo left by the previous belt, off the drive wheels.

In terms of electronics the EL3581 is not terribly exciting, after all it's a simple reel-to-reel tape recording machine using just two Mini-Watt audio tubes types ECC83 and EL95. A selenium rectifier is used for the HT supply rather than the expected EZ80. Never toast selenium parts — the fumes and debris are toxic and the smell is, well, one of a kind.

On the Internet, YouTube user 'CassetteMaster' from the US of A can be seen and heard demonstrating a Norelco EL3581 machine from his collection of dictation machines [2]. Judging from the clutter in his room and his way of speaking I thought CassetteMaster was even older than the machine he was filming but his sneakers and brief appearance on camera tell a different story.

Retronics Fans! If you recognize your mother or grandmother on the photos of the EL3581 user manual reproduced here, give me a call. Dictaphone or not, she looks like an efficient secretary for sure.

(120083)



[1] www.youtube.com/watch?v=wyM0H11-rjs&feature=related

[2] www.youtube.com/watch?v=DpTaZF8EBcE

[3] <http://www.archive.org/details/Secretar1947>

Retronics is a monthly column covering vintage electronics including legendary Elektor designs. Contributions, suggestions and requests are welcomed; please send an email to editor@elektor.com

Programmable Controllers:

Item #1336: Wixel Programmable USB Wireless Module



Motor Drivers:

Item #2502: Dual VNH5019 Motor Driver Shield for Arduino



Custom Laser Cutting:

Design Your Own Chassis



Finding the right parts for your robot can be difficult, but you also don't want to spend all your time reinventing the wheel (or motor controller). That's where we come in: Pololu has the unique products - from actuators to wireless modules - that can help you take your robot from idea to reality.

Pololu
Robotics & Electronics

www.pololu.com

CIRCUIT CELLAR

Spring Book Deal!

Save 15% and enter to win a free development kit!

ADuC841 Microcontroller Design Manual: From Microcontroller Theory to Design Projects

If you've ever wanted to design and program with the ADuC841 microcontroller, or other microcontrollers in the 8051 family, this is the book for you. With introductory and advanced labs, you'll soon master the many ways to use a microcontroller. Perfect for academics!



In April, **you'll save 15%** off the cover price plus have a chance to win a free ADuC841 QuickStart Development Kit! To enter the drawing **use coupon code ADKIT0412 at checkout.** The Analog Devices ADuC841 features a precision analog microcontroller: 20 MIPS 8052 Flash MCU + 8-channel 12-Bit ADC + Dual 12-Bit DAC.

Now Just \$29.75



Buy it today!

www.cc-webshop.com

* By entering coupon code ADKIT0412 at checkout you are indicating that you have read and agree to the terms and conditions posted at www.circuitcellar.com/books. The ADuC841 kit drawing is open to U.S. residents only and ends April 30, 2012.

sensors expo & conference

The Leading Sensors Event in North America

Pre-Conference: June 5, 2012
Conference & Expo: June 6-7, 2012

Donald E. Stephens Convention Center • Rosemont, IL

www.sensorexpo.com



The Only Industry Event in North America focused exclusively on sensors and sensor integrated systems.

Gain the knowledge you need from the leading experts and peers in the industry. This year's Conference Program includes more Technical Sessions in Tracks covering the topics that are most important to you and your business, including:

- Applied Sensing **NEW!**
- MEMS
- Sensor and System Design **NEW!**
- Energy Harvesting
- Mobile Sensing
- Wireless Sensing Solutions
- Novel Approaches to Measurement & Detection
- RFID **NEW!**



Identify specific solutions to your most difficult sensing, detection and control-related challenges on the Expo floor.

Sensors Expo brings together the largest and best-in-class showcase of sensing technologies and systems for attendees to evaluate and make informed decision. Plus – see new Pavilions on the Expo floor to help you easily find your specific sensor solution.

- BIG DATA & ANALYTICS PAVILION **NEW!**
- MEMS PAVILION
- MEMS INNOVATION AREA
- ENERGY HARVESTING PAVILION
- WIRELESS PAVILION **NEW!**



JUST ANNOUNCED!



Day 2 Keynote:
Assaf Biderman, Associate Director,
SENSEable City Laboratory

Thursday, June 7, 2012 • 9:00 AM – 10:00 AM

Subscribers: Visit www.sensorexpo.com to register today! Use discount code **A341F** for an **EXTRA \$50** off a Gold or Main Conference Pass!

Scan QR code to register on the go!



Get the free mobile app at <http://gettag.mobi>

Hexadoku

Puzzle with an electronics touch

Here's your monthly mission to keep the gray matter active. Hexadoku is the surest way to practice deep thinking, reduction, deduction and recombination. Get cracking, enter the right numbers in the puzzle below. Next, send the ones in the gray boxes to us and you automatically enter the prize draw for one of four Elektor Shop vouchers.

The instructions for this puzzle are straightforward. Fully geared to electronics fans and programmers, the Hexadoku puzzle employs the hexadecimal range 0 through F. In the diagram composed of 16 × 16 boxes, enter numbers such that **all** hexadecimal numbers 0 through F (that's 0-9 and A-F) occur once only in each row, once

in each column and in each of the 4×4 boxes (marked by the thicker black lines). A number of clues are given in the puzzle and these determine the start situation. Correct entries received enter a draw for a main prize and three lesser prizes. All you need to do is send us the numbers in the grey boxes.

Solve Hexadoku and win!

Correct solutions received from the entire Elektor readership automatically enter a prize draw for one Elektor Shop voucher worth \$ 140.00* and three Elektor Shop Vouchers worth \$ 70.00* each, which should encourage all Elektor readers to participate.

*Subject to exchange rate.

Participate!

Before May 1, 2012,

send your solution
(the numbers in the gray boxes) by email to

hexadoku@elektor.com

Prize winners

The solution of the February 2012 Hexadoku is: BEF8D.
The Elektor \$140.00 voucher has been awarded to Hans Berglund (Norway).
The Elektor \$70.00 vouchers have been awarded to Brian Unitt (UK),
Abdullah Saeed Bin Ali Jaber (Yemen) and Raúl Elguezabal Martínez (Spain).
Congratulations everyone!

| | | | | | | | | | | | | | | | |
|---|---|---|---|---|---|---|---|---|---|---|---|---|---|---|---|
| | | | A | | 6 | 2 | | D | | 9 | C | | | | |
| | | 9 | | | | | 6 | 3 | 1 | | | 7 | | | |
| 2 | | | | 4 | 7 | | 5 | | | | | 8 | E | | |
| B | F | | | A | 5 | 8 | | C | 7 | | 2 | 3 | | 6 | |
| 5 | 8 | | | 0 | 9 | D | 3 | | A | 6 | F | | E | | |
| | 7 | | B | A | | | 3 | | | 8 | | | 9 | 0 | |
| 0 | 9 | A | D | | 6 | | | | 2 | B | 7 | | | 8 | |
| | | | 6 | | | | | | 4 | 5 | | | 2 | | |
| | | B | | | D | 2 | | | | | | E | | | |
| D | | | 3 | 1 | B | | | | E | | 9 | A | 6 | 5 | |
| 9 | E | | | 5 | | | A | | | | C | B | | 4 | |
| | A | | 5 | C | | F | | 8 | 9 | B | 4 | | | 0 | 2 |
| F | | 2 | 0 | | C | 9 | | A | 7 | 6 | | | | B | D |
| 3 | D | | | | A | | | | B | 4 | | | | | 9 |
| | C | | | B | 1 | 3 | | | | | | | 0 | | |
| | B | 8 | | D | | | 0 | | F | | | C | | | |

| | | | | | | | | | | | | | | | |
|---|---|---|---|---|---|---|---|---|---|---|---|---|---|---|---|
| 3 | C | F | 8 | 1 | 6 | A | D | 2 | 4 | B | E | 5 | 9 | 7 | 0 |
| 1 | D | 0 | 9 | 4 | 5 | 7 | 3 | C | A | 6 | F | 8 | B | 2 | E |
| 2 | 4 | 5 | 7 | 9 | B | E | F | 8 | D | 0 | 3 | C | 6 | 1 | A |
| 6 | A | B | E | C | 8 | 0 | 2 | 1 | 7 | 9 | 5 | 3 | D | F | 4 |
| A | F | 6 | D | 2 | 0 | C | 4 | B | 1 | 3 | 7 | E | 8 | 9 | 5 |
| 4 | 2 | C | 0 | 3 | 9 | 6 | E | F | 5 | D | 8 | A | 7 | B | 1 |
| B | E | 1 | 3 | 5 | D | 8 | 7 | 9 | 2 | A | 4 | F | C | 0 | 6 |
| 7 | 8 | 9 | 5 | F | A | B | 1 | E | 0 | C | 6 | 2 | 3 | 4 | D |
| 5 | 0 | E | 6 | A | C | F | 9 | D | 8 | 4 | B | 1 | 2 | 3 | 7 |
| F | 9 | D | 2 | 7 | 1 | 5 | 8 | 0 | 3 | E | C | 4 | A | 6 | B |
| C | 1 | 3 | A | D | E | 4 | B | 5 | 6 | 7 | 2 | 0 | F | 8 | 9 |
| 8 | 7 | 4 | B | 6 | 2 | 3 | 0 | A | 9 | F | 1 | D | 5 | E | C |
| D | 5 | 2 | C | 0 | 4 | 1 | 6 | 3 | B | 8 | 9 | 7 | E | A | F |
| 9 | B | 7 | F | E | 3 | 2 | A | 4 | C | 1 | D | 6 | 0 | 5 | 8 |
| E | 3 | A | 4 | 8 | 7 | 9 | C | 6 | F | 5 | 0 | B | 1 | D | 2 |
| 0 | 6 | 8 | 1 | B | F | D | 5 | 7 | E | 2 | A | 9 | 4 | C | 3 |

The competition is not open to employees of Elektor International Media, its business partners and/or associated publishing houses.

Elektor Print

Classical reading: on paper



Elektor Digital

Contemporary & innovative reading:
on PC, notebook or tablet



Elektor PLUS

Comprehensive reading: at home and on the road

**Read Elektor with the
premium PLUS subscription!**

Subscribe now or upgrade: www.elektor.com/usa

ASSEMBLY LANGUAGE ESSENTIALS

Circuit Cellar's first book, *Assembly Language Essentials*, is a matter-of-fact guide to Assembly that will introduce you to the most fundamental programming language of a processor.

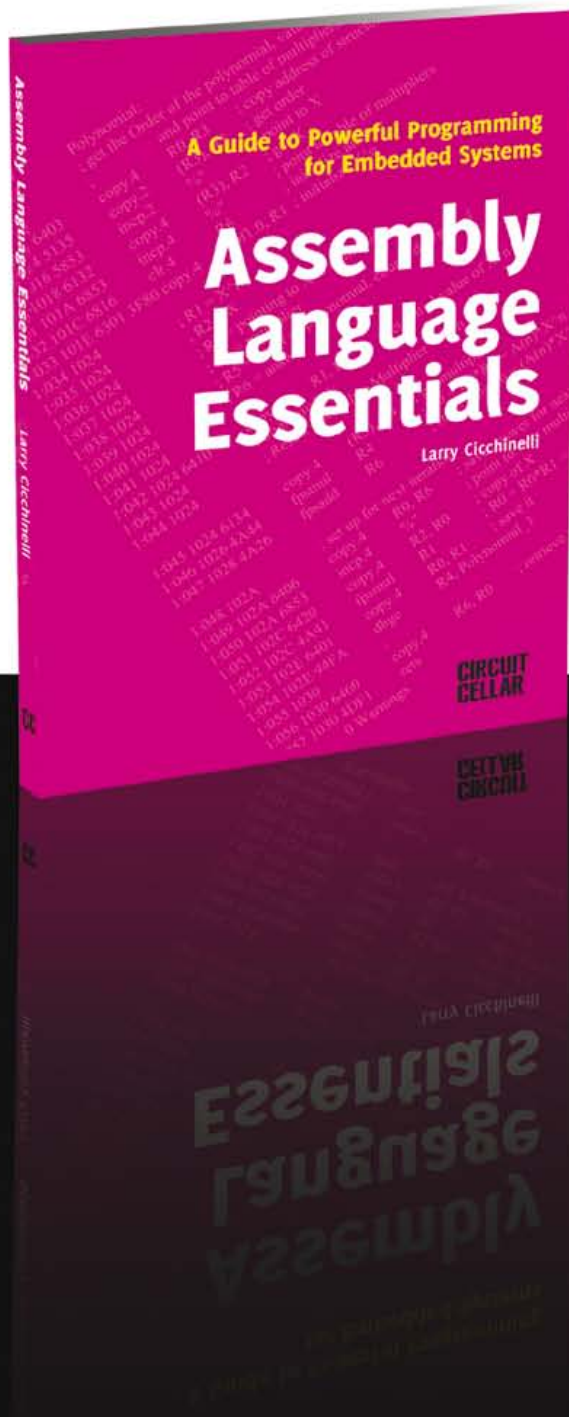

Author Larry Cicchinelli provides readers with:

- An introduction to Assembly language & its functionality
- Essential terminology pertaining to higher-level programming languages & computer architecture
- Important algorithms that may be built into high-level languages — multiplication, division, and polynomial evaluation
- Overview of Interrupt Service Routines
- Free, downloadable Assembler program ...
and more!

On Sale NOW!

\$47.50

ELEKTOR SHOWCASE

To book your showcase space contact Strategic Media Marketing Inc.

Tel. 1-978-281-7708

Fax 1-978-281-7706

Email ElektorUSA@smmarketing.us

SCOPES and more

HAMEG[®]
Instruments

A Rohde & Schwarz Company

www.hameg.com

**Great Value in
TEST & MEASUREMENT**



**SCIENCE,
ROBOTICS &
ELECTRONICS**
IMAGES Scientific Instruments Inc.

Microcontrollers
Servo Motor Controllers
Artificial Vision
Speech Recognition
Flex Sensors

www.imagesco.com

Tel: (718) 966-3694 Fax: (718) 966-3695

**THE NEXT
GENERATION OF
MAXSONAR**



The HRLV - MaxSonar Sensors

- Amazing One-Millimeter Resolution
- Simultaneous Multiple Sensor Operation
- Superior Noise Rejection
- Target Size Compensation for Accuracy
- Temperature Compensation (\$4.95)
- Outputs now include TTL Serial

\$34.95 (MSRP) www.MaxBotix.com

Pololu
Robotics & Electronics

Robot chassis, wheels,
casters, motors & servos

Save 10%
on motor controllers
with coupon code
ELEKTORMC94



\$49.95

Jrk USB motor controller
with feedback

RP5 chassis
\$49.95

Controllers, sensors,
cables, batteries & more!

Plastic SMT stencils &
custom laser cutting

www.pololu.com

**LISTEN
TO YOUR MACHINES**
Ethernet PLCs for OEMs

Ethernet PLCs for OEMs



From
\$119

- Built-in Ethernet
- MODBUS TCP/IP
- Digital and Analog I/Os
- PWM/PID/Stepper Control

Tel : 1 877 TRI-PLCS
web : www.tri-plc.com/ek.htm

TRI TRIANGLE
RESEARCH
INTERNATIONAL

BPS BusBoard
Prototype
Systems www.BusBoard.us

Many PCB styles
available

BB400T
Transparent
BreadBoard

SB400
Solderable PC
BreadBoard

Solder
and Keep

Build
and Test

Available from:
JAMECO
ELECTRONICS
amazon.com **MOUSER**
ELECTRONICS
a TI company

Microcontrollers 8 & 32 bit

| | |
|-------------|------------|
| MC9S08AS128 | MCF51AC256 |
| MC9S08CN128 | MCF51CN128 |
| MC9S08JM64 | MCF51JM128 |
| MC9S08QE128 | MCF51QE128 |

Bluetooth • RS-232 • USB • RF • 2x20 LCD
4x4 Keypad • Motor Control • Real Time Clock

Prototypes
quickly and easily

Explore
microcontrollers

Visit Us Now

Learn
programming



New Modules
For 2011

Experiment

ATRIA Technologies Inc.

www.AtriaTechnologies.com

AP CIRCUITS
PCB Fabrication Since 1984

As low as...

\$9.95
each!

Two Boards
Two Layers
Two Masks
One Legend

Unmasked boards ship next day!

www.apcircuits.com

VISA

MasterCard

PayPal

IPC MEMBER

BBB

**TO BOOK YOUR SHOWCASE SPACE
CONTACT STRATEGIC MEDIA MARKETING INC.**

Tel. 1-978-281-7708

Fax 1-978-281-7706

Email ElektorUSA@smmarketing.us

NEW BUD Board

BUD is a compact Atmel ATmega640 microcontroller board
with a big extra: when a BOB-4 module is installed, BUD
easily generates complex text and graphics on TV monitors.

INTRODUCTORY PRICING THROUGH JUNE 2012!



www.decadenet.com



DECADE ENGINEERING
503-743-3194 Turner, OR, USA

Going Strong

A world of electronics from a single shop!



**Package Deal
12% DISCOUNT**

Signal Generator + Universal Receiver + Active Antenna

AVR Software Defined Radio

(March 2012)

Atmel AVR microcontrollers are very popular, not least because of the free development tools that are available. In Elektor magazine we show how these processors can be pressed into service for digital signal processing tasks. This package consists of the three boards associated with the AVR Software Defined Radio articles series in Elektor, which is built around practical experiments. The first board, which includes an ATtiny2313, a 20 MHz oscillator and an R-2R DAC, will be used to make a signal generator. The second board will fish signals out of the ether. It contains all the hardware needed to make a digital software-defined radio (SDR), with an RS-232 interface, an LCD panel, and a 20 MHz VCXO (voltage-controlled crystal oscillator), which can be locked to a reference signal. The third board provides an active ferrite antenna. The software for all these projects is written using the WinAVR GCC compiler in AVR Studio and can be downloaded as C source code (plus fuse settings) or as hex files.

Signal Generator + Universal Receiver + Active Antenna: PCBs and all components
+ USB-FT232R breakout-board

Art.# 100182-72 • \$133.00



AndroPod

(February 2012)

With their high-resolution touchscreens, ample computing power, WLAN support and telephone functions, Android smartphones and tablets are ideal for use as control centres in your own projects. However, up to now it has been rather difficult to connect them to external circuitry. Our AndroPod interface board, which adds a serial TTL port and an RS485 port to the picture, changes this situation.

Andropod module with RS485 Extension

Art.# 110405-91 • \$74.70



Bestseller!

Improved Radiation Meter

(November 2011)

This device can be used with different sensors to measure gamma and alpha radiation. It is particularly suitable for long-term measurements and for examining weakly radioactive samples. The photodiode has a smaller sensitive area than a Geiger-Müller tube and so has a lower background count rate, which in turn means that the radiation from a small sample is easier to detect against the background. A further advantage of a semiconductor sensor is that it offers the possibility of measuring the energy of each particle, allowing a more detailed investigation of the characteristics of a sample. The optional PC-based software displays the energy spectrum, permitting a very detailed analysis to be carried out.

Kit of parts incl. display and programmed controller

Art.# 110538-71 • \$57.30

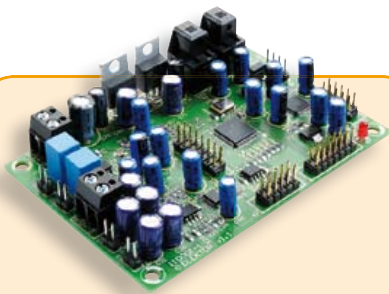

Audio DSP Course

(September 2011)

This DSP board is the platform for the applications described in our Audio DSP Course. It is also intended to enable you to develop your own initial digital audio signal processing applications. The DSP board can be used stand-alone as is, and even though it is an ideal learning platform, with its 24-bit signal processing capability for sampling rates up to 192 kHz and its high-performance interfaces, it is also suitable for applications with very stringent quality requirements for both signal to noise ratio and DSP computing power.

Populated and tested DSP board

Art.# 110001-91 • \$186.70



FT232R USB/ Serial Bridge/BOB

(September 2011)

You'll be surprised first and foremost by the size of this USB/serial converter – no larger than the moulded plug on a USB cable! And you're also bound to appreciate that fact that it's practical, quick to implement, reusable, and multi-platform – and yet for all that, not too expensive! Maybe you don't think much of the various commercially-available FT232R-based modules. Too expensive, too bulky, badly designed, ... That's why this project got designed in the form of a breakout board (BOB).

PCB, assembled and tested

Art.# 110553-91 • \$20.90

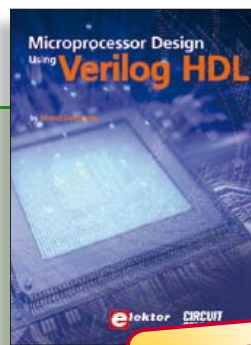

Bestseller!

Get going with Verilog Hardware Description Language

Microprocessor Design using Verilog HDL

If you have the right tools, designing a microprocessor shouldn't be complicated. The Verilog hardware description language (HDL) is one such tool. It can enable you to depict, simulate, and synthesize an electronic design, and thus increase your productivity by reducing the overall workload associated with a given project. This book is a practical guide to processor design in the real world. It presents the Verilog HDL in an easily digestible fashion and serves as a thorough introduction about reducing a computer architecture and instruction set to practice. You're led through the microprocessor design process from the start to finish, and essential topics ranging from writing in Verilog to debugging and testing are laid bare.

337 pages • ISBN 978-0-9630133-5-4 • \$45.00

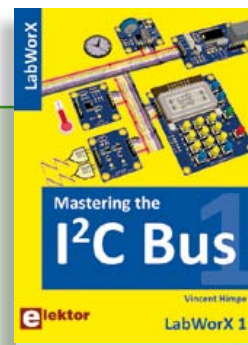

LabWorX: Straight from the Lab to your Brain

Mastering the I²C Bus

Mastering the I²C Bus is the first book in the LabWorX collection. It takes you on an exploratory journey of the I²C Bus and its applications. Besides the Bus protocol plenty of attention is given to the practical applications and designing a solid system. The most common I²C compatible chip classes are covered in detail. Two experimentation boards are available that allow for rapid prototype development. These are completed by a USB to I²C probe and a software framework to control I²C devices from your computer.

248 pages • ISBN 978-0-905705-98-9 • \$47.60

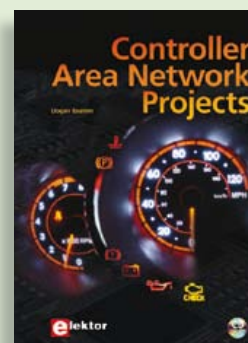

Free mikroC compiler CD-ROM included

Controller Area Network Projects

The aim of the book is to teach you the basic principles of CAN networks and in addition the development of microcontroller based projects using the CAN bus. You will learn how to design microcontroller based CAN bus nodes, build a CAN bus, develop high-level programs, and then exchange data in real-time over the bus. You will also learn how to build microcontroller hardware and interface it to LEDs, LCDs, and A/D converters.

260 pages • ISBN 978-1-907920-04-2 • \$47.60

More information on the
Elektor Website:

www.elektor.com

Elektor USA
4 Park Street
Vernon, CT 06066
USA
Phone: 860-875-2199
Fax: 860-871-0411
E-mail: order@elektor.com

elektor

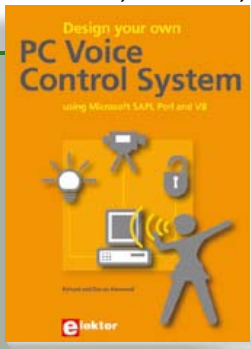

Talk with your computer
Design your own PC Voice Control System

This book guides you through practical speech recognition, speech announcement and control of really useful peripherals. It details a project which will enable you to instruct your computer using your voice and get it to control electrical devices, tell you the time, check your share values, get the weather forecast, etc. and speak it all back to you in a natural human voice. If you are interested in the practical technology of interfacing with machines using voice, then this book is your guide!

216 pages • ISBN 978-1-907920-07-3 • \$47.60

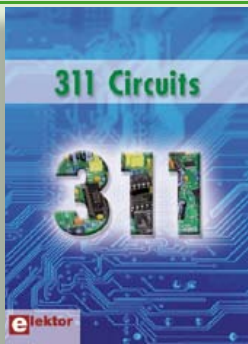

Creative solutions for all areas of electronics
311 Circuits

311 Circuits is the twelfth volume in Elektor's renowned 30x series. This book contains circuits, design ideas, tips and tricks from all areas of electronics: audio & video, computers & microcontrollers, radio, hobby & modelling, home & garden, power supplies & batteries, test & measurement, software, not forgetting a section 'miscellaneous' for everything that doesn't fit in one of the other categories. 311 Circuits offers many complete solutions as well as useful starting points for your own projects.

420 pages • ISBN 978-1-907920-08-0 • \$47.60



Bestseller!

A whole year of Elektor magazine onto a single disk

DVD Elektor 2011

The year volume DVD/CD-ROMs are among the most popular items in Elektor's product range. This DVD-ROM contains all editorial articles published in Volume 2011 of the English, American, Spanish, Dutch, French and German editions of Elektor. Using the supplied Adobe Reader program, articles are presented in the same layout as originally found in the magazine. An extensive search machine is available to locate keywords in any article. With this DVD you can also produce hard copy of PCB layouts at printer resolution, adapt PCB layouts using your favourite graphics program, zoom in/out on selected PCB areas and export circuit diagrams and illustrations to other programs.

ISBN 978-90-5381-276-1 • \$37.90



110 issues, more than 2,100 articles

DVD Elektor 1990 through 1999

This DVD-ROM contains the full range of 1990-1999 volumes (all 110 issues) of Elektor Electronics magazine (PDF). The more than 2,100 separate articles have been classified chronologically by their dates of publication (month/year), but are also listed alphabetically by topic. A comprehensive index enables you to search the entire DVD. This DVD also contains (free of charge) the entire 'The Elektor Datasheet Collection 1...5' CD-ROM series, with the original full datasheets of semiconductors, memory ICs, microcontrollers, and much more.

ISBN 978-0-905705-76-7 • \$111.30

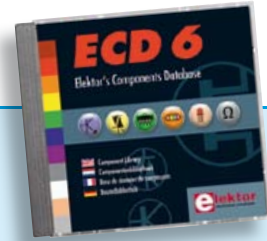

More than 70,000 components

CD Elektor's Components Database 6

This CD-ROM gives you easy access to design data for over 7,800 ICs, more than 35,600 transistors, FETs, thyristors and triacs, just under 25,000 diodes and 1,800 optocouplers. The program package consists of eight databanks covering ICs, transistors, diodes and optocouplers. A further eleven applications cover the calculation of, for example, zener diode series resistors, voltage regulators, voltage dividers and AMV's. A colour band decoder is included for determining resistor and inductor values. All data-bank applications are fully interactive, allowing the user to add, edit and complete component data. This CD-ROM is a must-have for all electronics enthusiasts!

ISBN 978-90-5381-258-7 • \$40.20



Circuits, ideas, tips and tricks from Elektor

CD 1001 Circuits

This CD-ROM contains more than 1000 circuits, ideas, tips and tricks from the Summer Circuits issues 2001-2010 of Elektor, supplemented with various other small projects, including all circuit diagrams, descriptions, component lists and full-sized layouts. The articles are grouped alphabetically in nine different sections: audio & video, computer & microcontroller, hobby & modelling, home & garden, high frequency, power supply, robotics, test & measurement and of course a section miscellaneous for everything that didn't fit in one of the other sections. Texts and component lists may be searched with the search function of Adobe Reader.

ISBN 978-1-907920-06-6 • \$55.70

April 2012 (No. 40)

\$

+ + + Product Shortlist April: See www.elektor.com + + +

March 2012 (No. 39)

AVR Software Defined Radio (1)

| | |
|--|--------|
| 080083-71 USB-AVR Programmer: SMD stuffed board and all components..... | 47.00 |
| 100180-71 Signal Generator kit; PCB and all components | 33.20 |
| 100181-71 Universal Receiver: PCB and all components..... | 83.10 |
| 100182-71 Active Antenna: PCB and all components | 33.20 |
| 100182-72 Signal Generator + Universal Receiver + Active Antenna: PCBs and all components..... | 133.00 |
| 110553-91 USB-FT232 breakout board, assembled and tested | 20.90 |

AndroPod (2)

| | |
|---|-------|
| 110258-91 USB/RS485 Converter: ready assembled module | 35.70 |
| 110405-91 Andropod module with RS485 Extension..... | 74.70 |
| 110553-91 USB-FT232 breakout board, assembled and tested | 20.90 |
| 120103-92 1.8m USB 2.0 A male to USB micro-B 5 pin black cable | 4.90 |
| 120103-94 5V / 1A (5W) PSU with micro-USB connector..... | 11.20 |

February 2012 (No. 38)

AndroPod (1)

| | |
|--|-------|
| 110258-91 USB/RS485 converter, ready-made module | 35.70 |
| 110405-91 Andropod module with RS485 Extension..... | 74.70 |
| 110553-91 USB-FT232R breakout board, assembled and tested | 20.90 |
| 120103-92 5-way cable USB 2.0 A male to USB micro-B, black..... | 5.70 |
| 120103-94 5V / 1A (5W) PSU with micro-USB connector..... | 12.90 |

Pico C-Plus and Pico C-Super

| | |
|---|------|
| 110687-41 Pico C-Plus controller, programmed (ATTINY2313-20PU)..... | 7.10 |
| 110687-42 Pico C-Super controller, programmed (ATTINY2313-20PU)..... | 7.10 |

Electronics for Starters (2)

| | |
|--|-------|
| ELEX-1 Prototyping board | 7.90 |
| ELEX-2 Prototyping board (double size) | 14.30 |

January 2012 (No. 37)

Wideband Lambda Probe Interface

| | |
|---|-------|
| 110363-41 Programmed controller ATMEGA8-16AU | 14.30 |
|---|-------|

Audio DSP Course (7)

| | |
|--|-------|
| 110002-71 Printed circuit board partly populated with SMD's | 71.80 |
|--|-------|

Grid Frequency Monitor

| | |
|---|-------|
| 110461-42 Programmed controller AT89C2051-24PU, for 60 Hz areas (USA) | 14.30 |
|---|-------|

Here comes the Bus! (11)

| | |
|--|-------|
| 110258-1 Experimental Node Board..... | 8.60 |
| 110258-1C3 .. 3 pcs Experimental Node Board | 18.60 |
| 110258-91 USB/RS485-Converter, ready made module..... | 35.90 |

Time / Interval Meter with ATtiny

| | |
|---|-------|
| 080876-41 Programmed ATtiny2313..... | 12.60 |
|---|-------|

December 2011 (No. 36)

Here comes the Bus! (10)

| | |
|---|-------|
| 110258-1 Experimental Node board..... | 8.60 |
| 110258-1C3 .. 3 pcs Experimental Node board | 18.60 |
| 110258-91 USB/RS485 Converter, ready made module | 35.90 |

USB Data Logger

| | |
|--|-------|
| 110409-1 Printed circuit board..... | 15.70 |
| 110409-41 Programmed controller PIC24FJ64GB002-I/sp dil-28s | 21.40 |

November 2011 (No. 35)

Improved Radiation Meter

| | |
|--|-------|
| 110538-41 Programmed controller ATmega88PA-PU..... | 15.10 |
| 110538-71 Kit of parts incl. display and programmed controller | 57.30 |

Bestsellers

| | | | | |
|----------------|---|---|--|----------|
| Books | 1 | ➡ | Microprocessor Design using Verilog HDL ISBN 978-0-9630133-5-4 | \$45.00 |
| | 2 | ➡ | Controller Area Network Projects ISBN 978-1-907920-04-2 | \$47.60 |
| | 3 | ➡ | 311 Circuits ISBN 978-1-907920-08-0 | \$47.60 |
| | 4 | ➡ | Mastering the I²C Bus ISBN 978-0-905705-98-9 | \$47.60 |
| | 5 | ➡ | Design your own PC Voice Control System ISBN 978-1-907920-07-3 | \$47.60 |
| CD/DVD-ROMs | 1 | ⬆ | DVD Elektor 2011 ISBN 978-90-5381-276-1 | \$37.90 |
| | 2 | ➡ | CD 1001 Circuits ISBN 978-1-907920-06-6 | \$55.70 |
| | 3 | ➡ | DVD Elektor 1990 through 1999 ISBN 978-0-905705-76-7 | \$111.30 |
| | 4 | ➡ | CD Elektor's Components Database 6 ISBN 978-90-5381-258-7 | \$40.20 |
| | 5 | ➡ | CD ATM18 Collection ISBN 978-0-905705-92-7 | \$39.60 |
| Kits & Modules | 1 | ➡ | Improved Radiation Meter Art. # 110538-71 | \$57.30 |
| | 2 | ➡ | FT232R USB/Serial Bridge/BOB Art. # 110553-91 | \$20.90 |
| | 3 | ⬆ | AVR SDR: Signal Generator kit Art. # 100180-71 | \$33.20 |
| | 4 | ➡ | Here comes the Bus! Art. # 110258-91 | \$35.90 |
| | 5 | ➡ | Audio DSP Board + Programmer Art. # 110001-92 | \$215.40 |

Order quickly and securely through
www.elektor.com/shop
 or use the Order Form near the end
 of the magazine!



Elektor USA
 4 Park Street
 Vernon, CT 06066
 USA
 Phone: 860-875-2199
 Fax: 860-871-0411
 E-mail: order@elektor.com



Stepper Motor Driver

A compact driver board was designed by Elektor Labs for controlling stepper motors, for instance, by way of the PC's parallel port. Use has been made of Allegro's A3979 driver chip, which is designed for controlling bipolar stepper motors in full, half, quarter and sixteenth-step modes. The board also sports optocouplers for electrical separation between the PC and the driver module. With an input voltage of 35 V and a maximum current of 1.5 A this driver is able to control the smaller Nema17 series motors with ease.

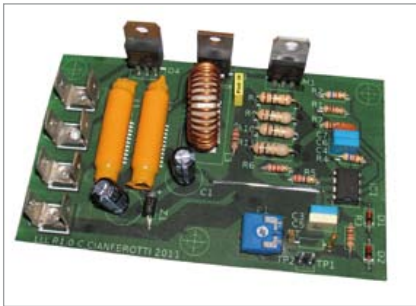

Lossless LED Load

Retrofit LED lamp units are increasingly used to replace standard light bulbs in cars and other vehicles. To prevent the error detection in the vehicle responding with a notification that a lamp is defective, a large bleeder resistor is usually fitted in parallel with the LED lamp to make sure enough current flows in the circuit. This is obviously a waste of energy. Our innovative circuit simulates a load in an energy-efficient way thanks to a trick. (photo shows author's prototype, an Elektor version is under development)



Embedded Linux Series

Nowadays Linux is actively running in many appliances, from coffee machines right up to industrial controllers. Many electronics fans would like to use Linux in their embedded designs, but often fear the seemingly high complexity. The high prices for Linux evaluation boards form an additional barrier. In the April 2012 edition we launch an 'Embedded Linux' series which hopefully eradicates both hindrances. For the course hardware we present a small and inexpensive Linux board with dual USB, SD Card interface, relays and many connecting options, so for all practical purposes you have everything you need to start designing and implementing a modern microcontroller application.

Article titles and magazine contents subject to change; please check the Magazine tab on www.elektor.com

Elektor UK/European April 2012 edition: on sale April 19, 2012.

Elektor USA March 2012 edition: published April 16, 2012.

www.elektor.com www.elektor.com www.elektor.com www.elektor.com www.elektor.com www.elektor.com

Elektor on the web

All magazine articles back to volume 2000 are available individually in pdf format against e-credits. Article summaries and component lists (if applicable) can be instantly viewed to help you positively identify an article. Article related items and resources are also shown, including software downloads, hyperlinks, circuit boards, programmed ICs and corrections and updates if applicable.

In the Elektor Shop you'll find all other products sold by the publishers, like CD-ROMs, DVDs, kits, modules, equipment, tools and books. A powerful search function allows you to search for items and references across the entire website.

Also on the Elektor website:

- Electronics news and Elektor announcements
- Readers Forum
- PCB, software and e-magazine downloads
- Time limited offers
- FAQ, Author Guidelines and Contact



| Description | Price each | Qty. | Total | Order Code |
|---|---|------|-------|------------|
| AVR Software Defined Radio Bundle (100182-72) | \$133.00 | | | |
| DVD Elektor 2011 | \$37.90 | | | |
| Microprocessor Design using Verilog HDL | \$45.00 | | | |
| 311 Circuits | \$47.60 | | | |
| Design your own PC Voice Control System | \$47.60 | | | |
| Controller Area Network Projects | \$47.60 | | | |
| LabWorX – Mastering the I²C Bus | \$47.60 | | | |
| Sub-total | | | | |
| Prices and item descriptions subject to change. The publishers reserve the right to change prices without prior notification. Prices and item descriptions shown here supersede those in previous issues. E. & O.E. | Shipping & Handling (Airmail from Europe) | \$ | 5.00 | |
| Total paid | | | | |

METHOD OF PAYMENT

Remit in US \$ drawn on a US bank. Please see next page for ordering information.

- Check or Money Order
- Mastercard
- VISA
- Discover
- American Express

| | | | | | | | | | | | | | | | | | | | |
|--|--|--|--|--|--|--|--|--|--|--|--|--|--|--|--|--|--|--|--|
| | | | | | | | | | | | | | | | | | | | |
|--|--|--|--|--|--|--|--|--|--|--|--|--|--|--|--|--|--|--|--|

Expiry date: _____

Verification code: _____

Send order form to:

Elektor USA
4 Park Street
Vernon, CT 06066
USA

Phone: 860-875-2199
Fax: 860-871-0411
E-mail: order@elektor.com
www.elektor.com/shop



Name/Company _____

Street & No. _____

City/State/Zip _____ Country _____

E-mail _____ Tel _____

EL04 Date - - Signature _____

Yes, I want to subscribe to Elektor US for 1 year*

I would like:

- Standard Subscription for \$40 (Canada \$55) (11 issues)
- Plus Subscription for \$60 (Canada \$70) (11 issues + the Elektor Volume 2012 DVD-ROM + exclusive access to www.elektor-plus-usa.com)**



METHOD OF PAYMENT

Remit in US \$ drawn on a US bank. Please see next page for ordering information.

- Check or Money Order
- Mastercard
- VISA
- Discover
- American Express

| | | | | | | | | | | | | | | | | | | | |
|--|--|--|--|--|--|--|--|--|--|--|--|--|--|--|--|--|--|--|--|
| | | | | | | | | | | | | | | | | | | | |
|--|--|--|--|--|--|--|--|--|--|--|--|--|--|--|--|--|--|--|--|

Expiry date: _____

Verification code: _____

Send order form to:

Elektor USA
P.O. Box 462228
Escondido, CA 92046

Phone: 800.269.6301
E-mail: elektor@pcspublink.com
www.elektor.com/subs-usa

Name/Company _____

Street & No. _____

City/State/Zip _____ Country _____

E-mail _____ Tel _____

EL04 Date - - Signature _____

* Offer available in US and Canada only.
** Please note: For a Plus subscription, it's important that you fill in your email address. This will enable you to have access to Elektor-plus-usa.com where you can browse an online Elektor archive exclusively available to Elektor Plus subscribers!

ORDERING INFORMATION

To order contact customer service:

Phone: 860-875-2199
Fax: 860-871-0411
Mail: Elektor US
4 Park Street
Vernon, CT 06066
USA
E-mail: order@elektor.com
On-line at www.elektor.com/shop

Customer service hours: 8:30 AM-4:30 PM EST Monday-Friday. Voice mail available at other times.
When leaving a message please be sure to leave a daytime telephone number where we can return your call.

PLEASE NOTE: While we strive to provide the best possible information in this issue, pricing and availability are subject to change without notice. To find out about current pricing and stock, please call or email customer service.

COMPONENTS

Components for projects appearing in Elektor are usually available from certain advertisers in the magazine. If difficulties in obtaining components are suspected, a source will normally be identified in the article. Please note, however, that the source(s) given is (are) not exclusive.

PAYMENT

Orders must be prepaid. We accept checks or money orders (in US \$ drawn on a US bank only), VISA, Mastercard, Discover, and American Express credit cards. We do not accept C.O.D. orders.
We also accept wire transfers. Add \$20 to cover fees charged for these transfers.

TERMS OF BUSINESS

Shipping Note: All orders will be shipped from Europe. Please allow 3–4 weeks for delivery. Shipping and handling via airmail: US \$20.00 per order. **Returns** Damaged or miss-shipped goods may be returned for replacement or refund. All returns must have an RA #. Call or email customer service to receive an RA# before returning the merchandise and be sure to put the RA# on the outside of the package. Please save shipping materials for possible carrier inspection. Requests for RA# must be received 30 days from invoice. **Patents** Patent protection may exist with respect to circuits, devices, components, and items described in our books and magazines. Elektor accepts no responsibility or liability for failing to identify such patent or other protection. **Copyright** All drawing, photographs, articles, printed circuit boards, programmed integrated circuits, diskettes, and software carriers published in our books and magazines (other than in third-party advertisements) are copyrighted and may not be reproduced (or stored in any sort of retrieval system) without written permission from Elektor. Notwithstanding, printed circuit boards may be produced for private and personal use without prior permission. **Limitation of liability** Elektor shall not be liable in contract, tort, or otherwise, for any loss or damage suffered by the purchaser whatsoever or howsoever arising out of, or in connection with, the supply of goods or services by Elektor other than to supply goods as described or, at the option of Elektor, to refund the purchaser any money paid with respect to the goods.

SUBSCRIPTIONS (US & CANADA ONLY)

Subscription rates (1 Yr.)

Standard Subscription: \$40 (Canada \$55)
Plus Subscription: \$60 (Canada \$70)

All subscriptions begin with the current issue. Expect 3–4 weeks for receipt of the first issue. Subscriptions, renewals, and change of address should be sent to:

Elektor USA
P.O. Box 462228
Escondido, CA 92046

E-mail: elektor@pcspublink.com

Order subscriptions on-line at www.elektor.com/subs-usa

Subscriptions may be paid for by check or money order (in US \$ drawn on a US bank only). We accept Mastercard, VISA, Discover and American Express credit cards.

For gift subscriptions, please include gift recipient's name and address as well as your own, with remittance. A gift card will be sent on request.
Subscriptions may be cancelled at any time for a refund of all unmailed issues.

Does your subscription expire soon?

Renew it online at www.elektor.com/subs-usa



Save

66%

off the cover price!

Delivering insightful analysis of the hottest topics in embedded tech

Subscribe to
Circuit Cellar NOW!

CIRCUIT CELLAR
THE WORLD'S SOURCE FOR EMBEDDED ELECTRONICS ENGINEERING INFORMATION

www.circuitcellar.com

Tired of Buttons & Knobs?

Your iPad, iPhone or iPod becomes the instrument

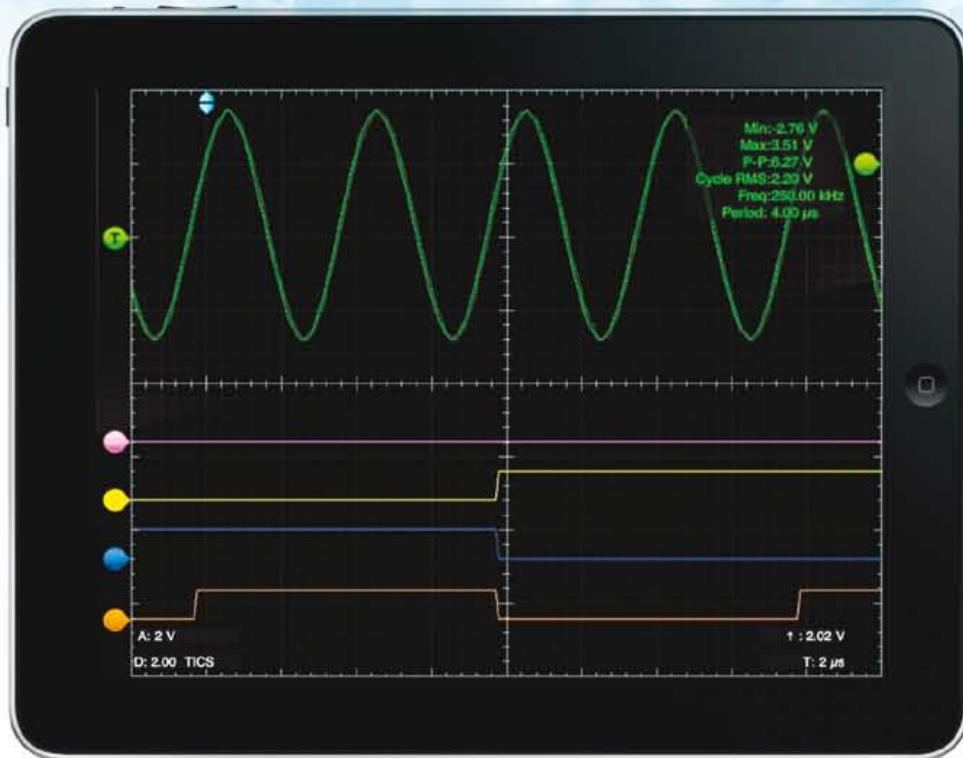

iMSO-104

Mixed Signal Oscilloscope
1 analog + 4 digital, 5MHz, 12MSPS, FFT



Made for
iPod iPhone iPad

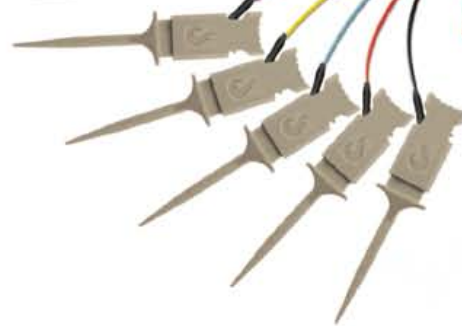

ACE AWARDS
2012 FINALIST
EE Times EDN

OSCIUM ELECTRONICS
DESIGN VISION AWARDS
2012 WINNER

Also Available:

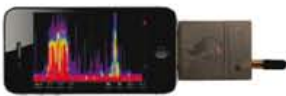

WiPry-Spectrum

2.400-2.495GHz, -40dBm to +20dBm
Resolution 2.0dBm, Sweep Time 200ms



WiPry-Power

100MHz to 2.7GHz, -45dBm to +20dBm
Resolution 0.2dBm, 2 μs/div to 1 s/div



WiPry-Combo

WiPry-Spectrum & WiPry-Power Combined!



OSCIUM

www.oscium.com