



elektor

electronics worldwide

Reflow Control

home-baked SMD boards from the oven

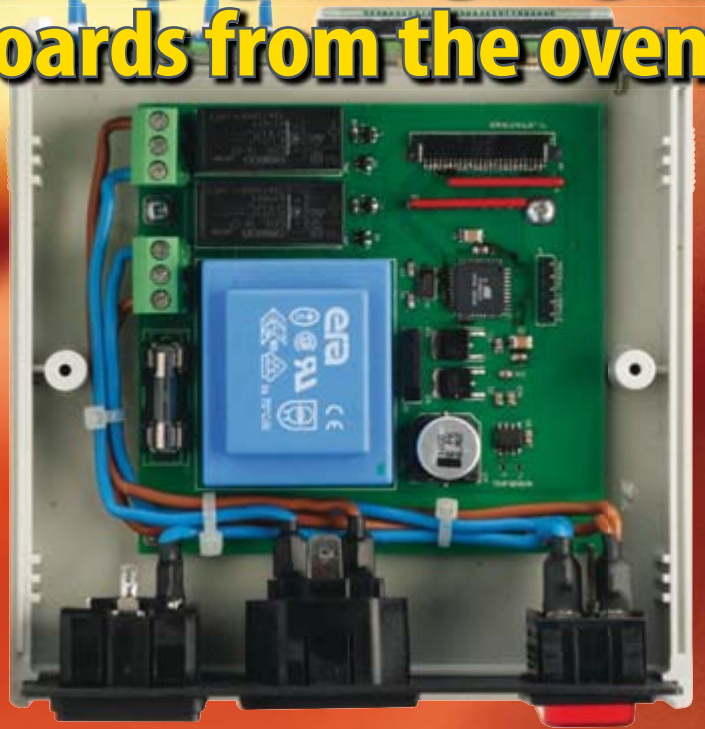

XMAS XTRA

The i-TRIXX collection

- ✓ Experimenters' Kits: still around!
and **nicer** than **ever**
- ✓ ATmega Webserver
reuse that ISA network card!



Great Kits for Electronics Enthusiasts

Top Selling Kits

DC Relay Switch

KC-5434 £4.50 + post & packing

An extremely useful and versatile kit that enables you to use a tiny trigger current - as low as 400µA at 12V to switch up to 30A at 50VDC. It has an isolated input, and is suitable for a variety of triggering options. The kit includes PCB with overlay and all electronic components with clear English instructions.

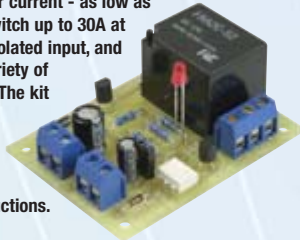

Two-Way SPDIF/Toslink Digital Audio Converter Kit

KC-5425 £7.25 + post and packing

This kit converts coaxial digital audio signals into optical or vice-versa. Use this bit stream converter in situations where one piece of equipment has an optical audio input and the other a coaxial digital output. Kit includes Toslink optical modules, PCB with overlay, case with screen printed lid, all electronic components and clear English instructions.

Requires 9-12VDC wall adaptor (Maplin #UG01B £13.99)

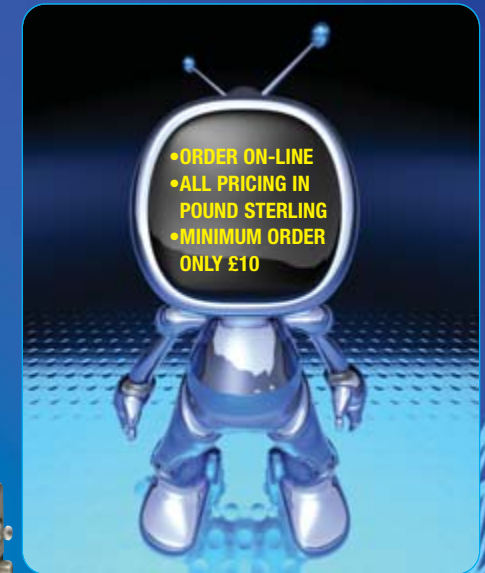

•ORDER ON-LINE
•ALL PRICING IN POUND STERLING
•MINIMUM ORDER ONLY £10

Battery Zapper MKII

KC-5427 £29.00 + post & packing

This kit attacks a common cause of failure in wet lead acid cell batteries: sulphation. The circuit produces short bursts of high level energy to reverse the damaging sulphation effect. This new improved unit features a battery health checker with LED indicator, new circuit protection against badly sulphated batteries, test points for a DMM and connection for a battery charger. Kit includes case with screen printed lid, PCB with overlay, all electronic components and clear English instructions. Suitable for 6, 12 and 24V batteries

- Powered by the battery itself



IR Remote Control Extender MKII

KC-5432 £7.25 + post & packing

Operate your DVD player or digital decoder using its remote control from another room. It picks up the signal from the remote control and sends it via a 2-wire cable to an infrared LED located close to the device. This improved model features fast data transfer, capable of transmitting Foxtel digital remote control signals using the Pace 400 series decoder. Kit supplied with case, screen printed front panel, PCB with overlay and all electronic components.

Requires 9VDC wall adaptor (Maplin #GS74R £10.99)



Handy Tools

Step Drill Bits

TD-2436 £6.50 + post and packing

TD-2438 £9.50 + post and packing

Drill multiple size holes with the one bit. Ideal for plastics and soft metals such as aluminium or copper sheeting up to 4mm thick. Made from high speed steel.

Two sizes available:

4 - 12mm in 1mm steps - TD-2436

12 - 20mm in 1mm steps - TD-2438



File Saw

TH-2127 £3.95 + post and packing

Perfect for cutting odd shaped holes in plastic pipes, plywood or other soft materials. It's not pretty, but it does the job.

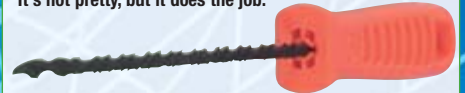

Budget 6" (150mm) Digital Vernier Calipers

TD-2081 £5.75 + post and packing

This carbon composite digital caliper is ideal for use where the cost of our precision stainless steel tool is not justified. The digital display is calibrated in imperial and metric units and a corresponding vernier scale is etched onto the caliper slide. Excellent value for money and tradesman tough.



6 in 1 Foldable Keyring Tool

TH-1904 £1.50 + post and packing

This handy tool is a wire cutter, standard pliers, crimping tool, wrench, and a Phillips and slotted screwdriver all in one! Folded up, it measures just 48 x 30mm.

Lightweight and compact. A perfect companion to your keyring.



Universal High Energy Ignition Kit

KC-5419 £27.75 + post & packing

A high energy 0.9ms spark burns fuel faster and more efficiently to give you more power! This versatile kit can be connected to conventional points, twin points or retractor ignition systems. Kit supplied with diecast case, PCB and all electronic components.



Build-Yourself Electronic Project Kits

Looking for a particular KIT?

Checkout Jaycar's extensive range.

We have kits and electronic projects for use in:

- Audio & Video
- Car & Automotive
- Computer
- Learning & Educational
- Lighting
- Power
- Test & Meters
- General Electronics Projects - just for fun!



430+ pages
ALL prices in PDS

Post and Packing Charges

Order Value	Cost	Order Value	Cost
£10 - £49.99	£5	£200 - £499.99	£30
£50 - £99.99	£10	£500+	£40
£100 - £199.99	£20		

Max weight 12lb (5kg). Heavier parcels POA.
Minimum order £10.

Note: Products are despatched from Australia, so local customs duty and taxes may apply.

How to order:

Phone: Call Australian Eastern Standard Time Mon-Fri on 0800 032 7241

Email: techstore@jaycarelectronics.co.uk

Post: PO BOX 6424, Silverwater NSW 1811. Australia

Expect 10-14 days for air parcel delivery

Check out the Jaycar range in your FREE Catalogue - logon to

www.jaycarelectronics.co.uk/elektor

or check out the range at

www.jaycarelectronics.co.uk

0800 032 7241

(Monday - Friday 09.00 to 17.30 GMT + 10 hours only)

For those who want to write: 100 Silverwater Rd
Silverwater NSW 2128 Sydney AUSTRALIA

Jaycar
Electronics

BitScope USB Mixed Signal Oscilloscope

Analog + Digital

Digital Storage Oscilloscope

- ✓ Dual Channel Digital Scope with industry standard probes or POD connected analog inputs. Fully opto-isolated.

Mixed Signal Oscilloscope

- ✓ Capture and display analog and logic signals together with sophisticated cross-triggers for precise analog/logic timing.

Multi-Band Spectrum Analyzer

- ✓ Display analog waveforms and their spectra simultaneously. Base-band or RF displays with variable bandwidth control.

Multi-Channel Logic Analyzer

- ✓ Eight logic/trigger channels with event capture to 25nS.

DSP Waveform Generator

- ✓ Built-in flash programmable DSP based function generator. Operates concurrently with waveform and logic capture.

Mixed Signal Data Recorder

- ✓ Record to disk anything BitScope can capture. Supports on-screen waveform replay and export.

User Programmable Tools and Drivers

- ✓ Use supplied drivers and interfaces to build custom test and measurement and data acquisition solutions.

Inventing the future requires a lot of test gear...
...or a BitScope



BS100U Mixed Signal Storage Scope & Analyzer

Innovations in modern electronics engineering are leading the new wave of inventions that promise clean and energy efficient technologies that will change the way we live.

It's a sophisticated world mixing digital logic, complex analog signals and high speed events. To make sense of it all you need to see exactly what's going on in real-time.

BS100U combines analog and digital capture and analysis in one cost effective test and measurement package to give you the tools you need to navigate this exciting new frontier.



Standard 1M/20pF BNC inputs

Smart POD Connector



Opto-isolated USB 2.0

12VDC with low power modes

BitScope DSO Software for Windows and Linux

BS100U includes BitScope DSO the fast and intuitive multichannel test and measurement software for your PC or notebook.

Capture deep buffer one-shots, display waveforms and spectra real-time or capture mixed signal data to disk. Comprehensive integration means you can view analog and logic signals in many different ways all at the click of a button.

The software may also be used stand-alone to share data with colleagues, students or customers.

Waveforms may be exported as portable image files or live captures replayed on another PC as if a BS100U was locally connected.

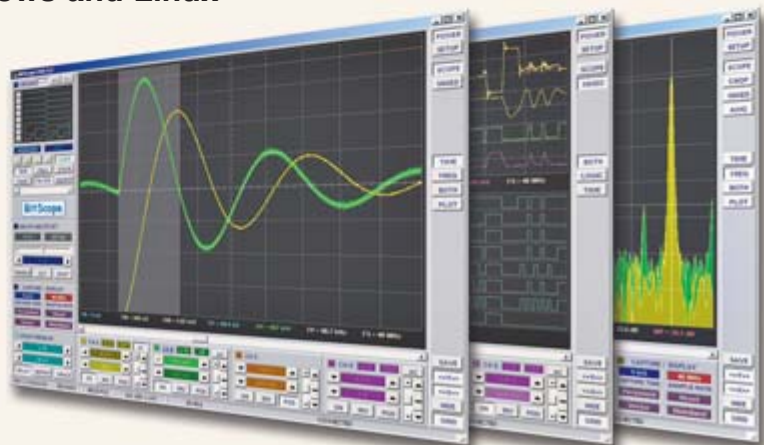

www.bitscope.com

Call for papers

One of the most frequent questions I get, usually by email but occasionally by telephone or letter (!) is "can I contribute to your wonderful publication and if so, what are the requirements and the specific subjects you are interested in?" The answer is invariably, "Yes, please, we're ready to evaluate the publication value of your article proposal Please review the Author Guidelines^[1] document available under the Service tab on our website at www.elektor.com". To this I usually add a few encouraging words and a pointer to Elektor's Publishing Plan^[2] for the current year. Now if this sounds like a straightforward approach to you, you should know that some of our competitors simply do not accept articles from persons outside their circle of 'approved authors' nor arrange for theme-driven content of their publications.

This year, in addition to the broad terms used in the Publishing Plan for the 12 months ahead of us in 2008, we have ventured to add a third column listing some keywords that hopefully trigger a response from you. For example, for the June 2008 issue focusing on Cool Electronics, why not send us your contribution on PC cooling, smart heatsinks, or electronics in clothes to keep you cool? Contributions from companies, journalists and workers in the industry are also welcomed. Although the 2008 schedule has been online for just two weeks now, the approach seems to work — three major articles are already in stock for publishing.

Now, for the solemn bit: about 70 percent of the article proposals reaching us through all international channels sadly gets rejected for publication. The reasons for the team of editors and designers be so harsh and unkind to budding authors include uninventive use of components; the use of obsolete components; re-hashing manufacturer's datasheets or old Elektor articles (!); vague circuits nicked from websites, poor electronic design and attempts to use the magazine as a catalogue for their products. The rest is gladly considered for publication and/or post-engineering by our lab, no matter if the piece is poorly written or the prototype built on perfboard — in general we are good humoured with a keen eye for originality. Even if it takes a while for us to get back to you due to the work load here at Elektor House, give us a try and eventually see your name (and circuit!) in print — it's by no means difficult, we're here to help.

Jan Buiting, Editor

[1] www.elektor.com/author_guide

[2] www.elektor.com/publishing_plan

Reflow Solder Controller

16

Here we present the control electronics for a do-it-yourself SMD oven. It is even available as a kit of parts, making the construction easy provided you know your bit about electrical safety regulati-



ons. In good Elektor tradition, in an associated article (starting on page 20) we supply a series of useful tips for the practical use of a reflow oven.

20 Reflow Techniques



24 AVR Webserver

In the world of Open Source technology seemingly nothing is impossible. What's more, it's entirely feasible to cram the code for a webserver into an ATmega32 microcontroller. External control and connectivity for a webcam make this project even more attractive.

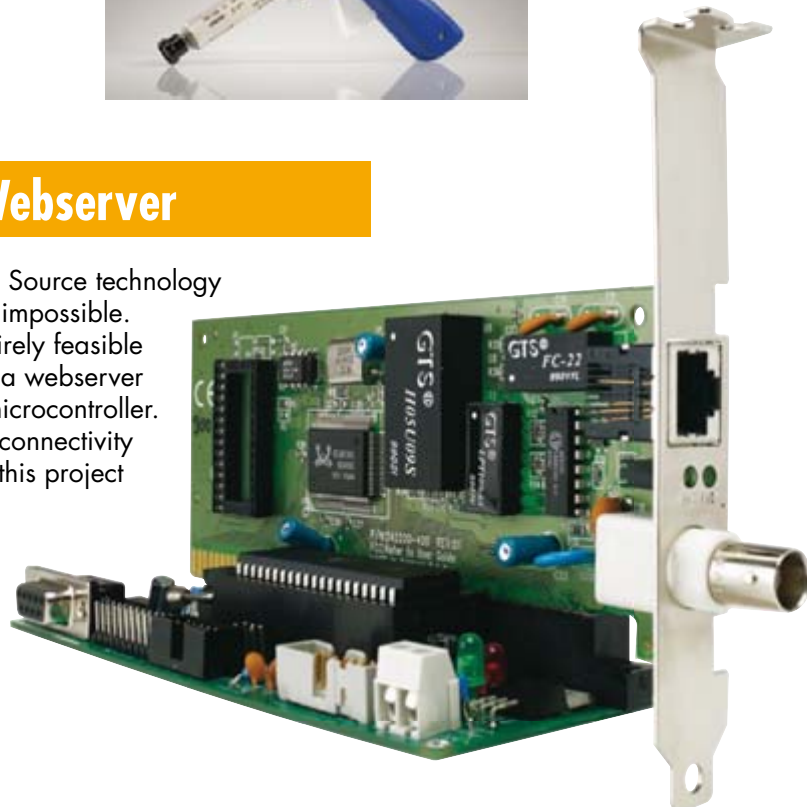

CONTENTS

What could be nicer for an electronics enthusiast than to help his or her children take their first steps into the world of electronics? Electronics lab kits let children of all ages experiment with electronics to their heart's content.

40 Learn Young...



**FREE 24-page
i-TRIXX supplement**

starts on page 45



**Merry Christmas and a happy,
peaceful 2008 from all at Elektor!**

70 Micromechanical Silicon Gyroscopes

In technological terms the progress being made in micromechanical sensors is enormous. Particularly commercially interesting examples of this are accelerometers and rotation sensors, also called gyroscopes. As manufacturing prices inexorably fall, so the number of applications rises. Stefan Tauschek reports.



**Volume 33
December 2007
no. 372**

projects

- 16** Reflow Solder Controller
- 24** AVR Webserver
- 30** VR Stamp™ Toolkit
- 34** Craft Drill Controller
- 76** E-blocks DCF Clock
- 84** Power on Tap
- 92** LED's Dive!
- 95** Design Tips: a Mini DI
- 96** LED Brake/Rear Light

technology

- 20** Reflow Techniques
- 70** Micromechanical Silicon Gyroscopes
- 98** IC-free (almost)

info & market

- 6** Colophon
- 8** Mailbox
- 10** News & New Products
- 40** Learn Young...
- 84** i.MX21 ARM9 Linux Board (review)
- 104** Elektor SHOP
- 108** Sneak Preview

infotainment

- 80** A Radiant Future
- 100** Hexadoku
- 101** Retronics: Philips 'SXA' VHF/UHF Handheld (1977)

elektor international media

Elektor International Media provides a multimedia and interactive platform for everyone interested in electronics.

From professionals passionate about their work to enthusiasts with professional ambitions.

From beginner to diehard, from student to lecturer. Information, education, inspiration and entertainment.

Analogue and digital; practical and theoretical; software and hardware.



English
German
Dutch
French
Chinese



Greek
Spanish
Swedish
Finnish

Volume 33, Number 372, December 2007

ISSN 0268/4519

Elektor Electronics aims at inspiring people to master electronics at any personal level by presenting construction projects and spotting developments in electronics and information technology.

Publishers: Elektor International Media, Regus Brentford, 1000 Great West Road, Brentford TW8 9HH, England. Tel. (+44) 208 261 4509, fax: (+44) 208 261 4447 www.elektor.com

The magazine is available from newsagents, bookshops and electronics retail outlets, or on subscription.

Elektor is published 11 times a year with a double issue for July & August.

Elektor is also published in French, Spanish, German and Dutch. Together with franchised editions the magazine is on circulation in more than 50 countries.

International Editor:
Wisse Hettinga (w.hettinga@elektor.nl)

Editor: Jan Buiting (editor@elektor.com)

International editorial staff: Harry Baggen, Thijs Beckers, Ernst Krempelsauer, Jens Nickel, Guy Raedersdorf.

Design staff: Antoine Authier, Ton Giesberts, Paul Goossens, Luc Lemmens, Jan Visser, Christian Vossen

Editorial secretariat: Hedwig Hennekens (secretariaat@elektor.nl)

Graphic design / DTP: Giel Dols, Mart Schroijen

Managing Director / Publisher: Paul Snakkers

Marketing: Carlo van Nistelrooy

Customer Services: Anouska van Ginkel

Subscriptions: Elektor International Media, Regus Brentford, 1000 Great West Road, Brentford TW8 9HH, England. Tel. (+44) 208 261 4509, fax: (+44) 208 261 4447
Internet: www.elektor.com

Formula Flowcode Buggy

USB-programmable robot vehicle (incl. CD-ROM)

Ready to use for only **£85.00**
US\$ 169.00

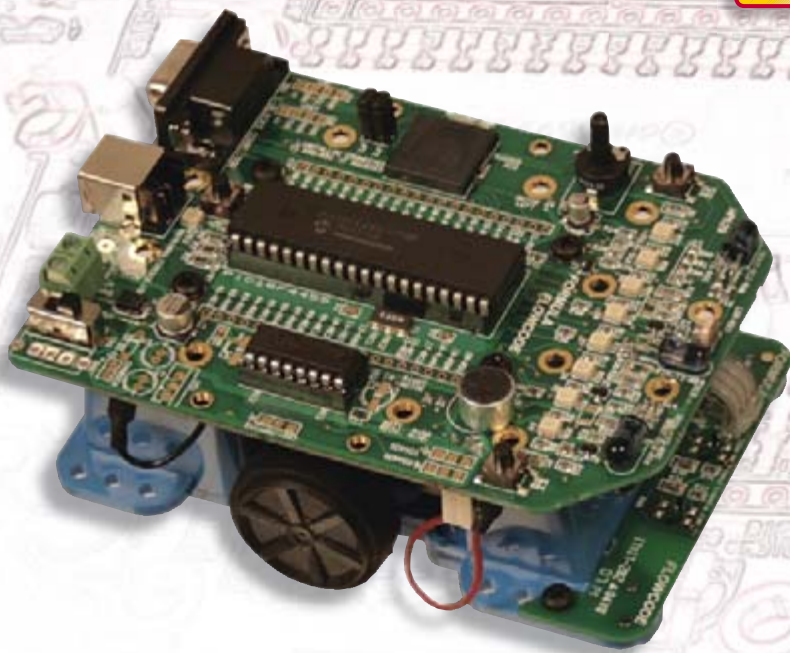

- A complete solution: robot + software + curriculum
- Line following and maze solving
- High-tech specifications
- Also programmable with C or ASM
- E-blocks compatible
- Motivating for education and hobby

elektor
SHOP

Order quickly and safe through www.elektor.com/shop
or use the Order Form near the end of the magazine

Email: subscriptions@elektor.com
Rates and terms are given on the Subscription Order Form

Head Office: Elektor International Media b.v.
P.O. Box 11 NL-6114-ZG Susteren The Netherlands
Telephone: (+31) 46 4389444, Fax: (+31) 46 4370161

Distribution: Seymour, 2 East Poultry Street, London EC1A, England
Telephone: +44 207 429 4073

UK Advertising: Huson International Media, Cambridge House,
Gogmore Lane, Chertsey, Surrey KT16 9AP, England.
Telephone: +44 1932 564999, Fax: +44 1932 564998

Email: p.brady@husonmedia.com
Internet: www.husonmedia.com
Advertising rates and terms available on request.

International Advertising: Frank van de Raadt, address as Head Office
Email: advertenties@elektor.nl
Advertising rates and terms available on request.

Copyright Notice
The circuits described in this magazine are for domestic use only. All drawings, photographs, printed circuit board layouts, programmed integrated circuits, disks, CD-ROMs, software carriers and article texts published in our books and magazines (other than third-party advertisements) are copyright Segment. b.v. and may not be reproduced or transmitted in any form or by any means, including photocopying, scanning or recording, in whole or in part without

prior written permission from the Publishers. Such written permission must also be obtained before any part of this publication is stored in a retrieval system of any nature. Patent protection may exist in respect of circuits, devices, components etc. described in this magazine. The Publisher does not accept responsibility for failing to identify such patent(s) or other protection. The submission of designs or articles implies permission to the Publishers to alter the text and design, and to use the contents in other Segment publications and activities. The Publishers cannot guarantee to return any material submitted to them.

Disclaimer
Prices and descriptions of publication-related items subject to change.
Errors and omissions excluded.

© Elektor International Media B.V. 2007

Printed in the Netherlands

Classy Class-A Amp

Dear Jan — I thought I would drop you a line to say I have recently finished building your design for a valve amplifier published in the June 2007 issue. I built my amp using an upside down oven roasting dish, this may sound strange but these trays are great as they are quite strong and most have a Teflon coating which saves painting. I also wound my own E.I transformers from your specs as I have the equipment to do so.

Thanks for the design, it works very well, sounds great and manages to achieve the figures you quoted for it. I sometimes build designs from the net but sad to say some don't live up to expectations. I find that designs in well known magazines are researched well and work well. I do however have a couple of minor criticisms — pin numbers for V2.B are incorrect and C7 is the wrong way around. One again, thanks for the circuit and I'll keep checking for future designs.

Keith Columbine (Australia)



Thanks for that Keith, somehow we knew the design of the valve amp was a dead cert because the author came to our audio lab and gave a very convincing demonstration of his own unit. The amp was not only pictured for the article, but also 'grilled' for an hour or so by our engineers to verify its performance. No smoke, no burnt crusts or fingers, just lovely 'tube sound' when playing our test CDs. Well recommended, that one.

The corrections you mention were published on the project page found our website.

Nice reminiscences

Dear Sirs — it was nice to read a little history about Elektor in the October 2007 issue. I have been in the electro-mechanical industry for some 47 years now, we have all seen a lot of changes in the way our hobby has grown. I must admit that at times I seemed baffled and came up against a hard wall with some projects. Maybe this is all part of growing older. But I still get a lot of pleasure

from this hobby, even if it is only in reading matter. Up until the year 2000, I had every copy of your magazine, they were all neatly filed and stored. Alas, I re-married and lost my storage space and had to part with 99% of them, I think I understand my wife when she says "you can't keep them up to date all the time". On a different note, I would like to see an article on the storage of data from an Oregon Scientific

WMR926NX Weather station. In other words 'an SD card and interface' that can be downloaded to the PC in my time instead of real time, this would save on energy! All the best for the future.

Alan Pattison (UK)

That's such nice things you wrote there, Alan, I may want to publish it in Mailbox, December 2007. (there, I did it!

I have passed your design request to our lab and a number of freelance contributors.



other household devices are assured of a source of power for a long time (or at least I hope so).

But that's not the end of the story. After all, I had a nice pile of electronic tea lights, and with my natural curiosity I had to take a closer look at them.

After opening up one of them, I found that the flickering light effect was produced by an IC embedded in a drop of hard plastic. At first I thought it was a random-number generator, but after watching for a while I discovered a certain repetitive pattern in the flickering. Then I wondered how it would sound if I connected it to a speaker. I quickly got out my soldering iron, soldered a short length of cable to the pins of the LED, and connected the other end of the cable to my audio system. To my utter amazement, the tea light was playing 'Happy Birthday'! The chip in the tea light is obviously the same kind you find in musical greeting cards.

Using a phototransistor and the amplifier from a portable FM scanner, I quickly put together a tea light music detector. It turned out that slightly more than half of the tea lights played 'Happy Birthday', while the rest played a melody that I didn't recognise. There is thus some variation in them. Now we have a new subject of conversation for birthday get-togethers: 'What tunes do your tea lights play?'

Martien Jansen (Netherlands)

Software for SDR receiver

Dear Editor — in response to your SDR receiver article in the May 2007 issue, I bought the fully assembled board.

CR2032 and musical tea lights

Dear Jan — I noticed the other day that the CMOS battery of one of my PCs was dead. You've probably seen the familiar start-up message, 'CMOS checksum error, defaults loaded'. It turned out to be a 3.3-V lithium battery, type CR2032, which is used not only on PC motherboards but also in all sorts of other equipment, such as home automation remote-control units, heart rate monitors, and so on.

As this type of battery from a top-name manufacturer can easily set you back several euros, I decided to look for a cheaper alternative. I remembered that I had seen an advert from a major discounter for 'electronic tea lights' that were powered by a button cell that appeared to be very close to the size and shape of the CR2032. You've probably seen tea light of this sort, with a tea-warmer candle where the wick has been replaced by a flickering yellow LED in a flame-shaped housing.

After ploughing through the weekly stack of junk mail in my letterbox, I indeed found an advert for 'electronic tea lights, battery included, 2 for 75p'.

In the shop I discovered that I was in luck: the batteries were type C2032. Although they were probably not top-brand batteries, I could hardly complain about the price, and I picked up a sizeable quantity. Now my motherboard and

However, the software you offer did not meet my wishes. I preferred the WinRad program from Alberto (I2PHD), although it did not have an interface to your SDR receiver, but it does have a well-documented API that can be used to produce a suitable interface.

Armed with the WinRad, FTDI and Cypress data sheets and APIs, I went to work and generated an interface DLL for linking your SDR receiver to WinRad. The initial version of this library can be found on my website at <http://home.gjk4all.net/winrad-dll/>. The source code for the DLL can also be downloaded from this site. I have placed the code under the GPL licence to prevent commercial exploitation.



I am sending you this message because I would like to make your readers aware of WinRad and because I think that using this package increases the versatility of your receiver. I thus hope that you will inform your readers that your SDR receiver can be linked to WinRad.

Gert Jan Kruizinga
(Netherlands)

This is without question interesting information for other readers, and it certainly deserves a place in our Mailbox forum!

Audio test CDs

Dear Jan — I am looking for a test CD (or a copy of one) with third-octave noise tracks so I can make some quick tests on loudspeakers without using a PC. A few years ago, you could get CDs of this sort from Stax (among others), but they are no longer available

because all test programs nowadays work with PC sound cards.

However, I'm sure that loud-speaker hobbyists must have various CDs of this sort tucked away in a drawer somewhere. Who can help me out?

Jocelyn Hayes (UK)

We managed to find two CDs. You can still order test CDs from http://www.rainfall.com/cdroms/pink_noise.htm and <http://www.rivesaudio.com/software/TestCD.html>. There is almost certainly software available that can generate the signals you need, but it probably costs more than the test CDs.

Replacement LED driver PCB

Dear Elektor people — the replacement for the defective LED driver board attached to the September issue arrived in good order, thanks for that. I immediately connected two white LEDs to it, along with a 1.5-V microcell that had just been removed from some other equipment, and the LEDs are still lit up on the second day now. Thanks once again for your trouble.

Ruprecht Hayna



As already reported on our forum, we have sent new LED driver boards at no charge in cases where the boards included with the September 2007 issue did not operate properly due to damage in transport. We would

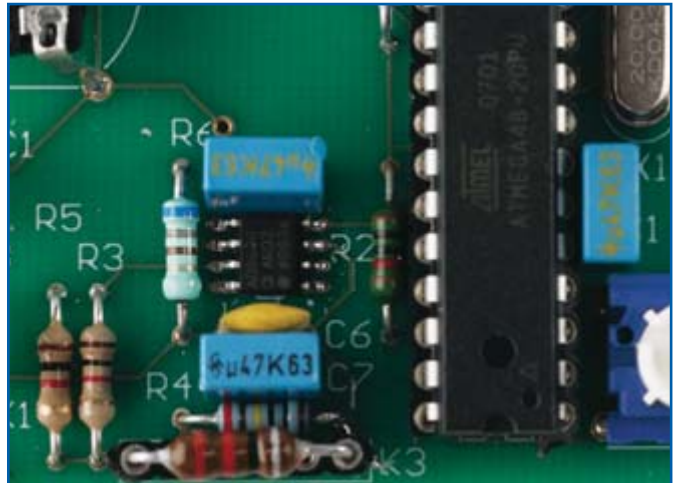

like to once again state that the inductors were delivered in perfect condition from the manufacturer (Würth-Electronics) and that the assembly work performed by ECS was also free of errors. The damage that occurred is entirely due to severe mechanical stresses (pressure and impact loads) during distribution of the magazine.

Calibration tip for Coil Clinic

When I tried to calibrate the Coil Clinic inductance meter published in the June 2007 issue of Elektor with the specified 22 μH and 220 nH coils, an 'Out of range' message was always displayed with the 220 nH coil. There were no problems with the 22 μH coil. The values of the reference coils that I used were measured with an accuracy of 1% using an HP LCR meter. All coils with a value of 180 nH or less yielded a 'No value' message (no oscillation). The calibration process worked perfectly after I replaced C6 and C7 with high-quality SMD capacitors. Now the measuring range extends down to slightly less than 100 nH. The value of C6 is definitely 4.7 nF, as indicated on the schematic diagram, since the combination of 100 nH and 4.7 nF yields a resonant frequency of about 7.3 MHz. The value of C6 is stated incorrectly as 4.7 μF in the components list.

The displayed value is very stable now. The meter ran all night with a 220-nH calibration inductor, and the next morning it still displayed exactly 220 nH.

Norbert Kohns, DG1KPN

Thank you for your tip, which will be very helpful in case anyone else has a quality problem with C6 and C7. Fortunately, the components list error is 'harmless' because the value shown on the schematic diagram is correct and there is simply not enough room on the PCB for an electrolytic capacitor in the C6 position. A glance at the photo of the prototype board (Figure 3 in the article) should eliminate any doubt.

MailBox Terms

- Publication of reader's correspondence is at the discretion of the Editor.
 - Viewpoints expressed by correspondents are not necessarily those of the Editor or Publisher.
 - Correspondence may be translated or edited for length, clarity and style.
- When replying to Mailbox correspondence, please quote Issue number.
- Please send your MailBox correspondence to:

editor@elektor.com or
Elektor, The Editor,
1000 Great West Road,
Brentford TW8 9HH, England.

1,000 Lumens from a single LED

Cree, Inc. announced it has demonstrated light output of more than 1,000 lumens – an amount equivalent to the output level of a standard household light bulb – from a single R&D LED. Cree’s achievement demonstrates continued leadership in the development of LEDs that can make traditional light bulbs obsolete. A single-die LED, driven at 4

amps, produced 1,050 lumens in cool white and 760 lumens in a warm-white version. Efficacy of the cool-white LED was 72 lumens per watt and 52 lumens per watt from the warm-white device. Both LED versions operated at substantially higher efficacy levels than those of today’s conventional light bulbs. Historically, Cree’s R&D demonstrations generally have been

commercialized within 12 to 24 months.

Cree’s product families include blue and green LED chips, lighting LEDs, LEDs for backlighting, power-switching devices and radio-frequency/wireless devices.

www.cree.com

(070723-VII)

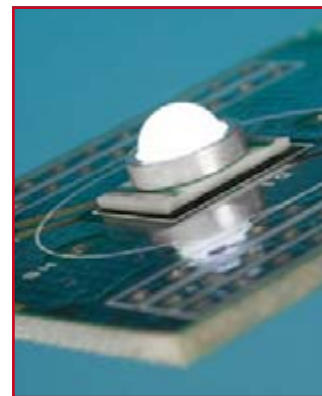

USB-to-Ethernet device server for synchronised audio/video Data transfer

Lantronix, Inc. announced their UBox® 2100, the first USB-to-Ethernet device server to support the USB isochronous data transfer standard, typically used for audio and video applications. With UBox 2100, users can put virtually any off-the-shelf USB 2.0 peripheral device on an Ethernet network. Removing the distance limitations normally associated with USB, users can access and share a variety of devices such as web cams, speakers, microphones, sensors, security access equipment, multi-function printers, hard drives, scanners – even Apple® iPods® – over the Internet.

Isochronous data transfer is typically used for time-dependent applications, such as multimedia streams with synchronised audio and video where the data must be delivered within specific time constraints. Along with its support for isochro-

nous data transfer, UBox eliminates the need to directly connect devices to a PC, thus IP-enabling the USB devices. For example, users can access and

share web cams with fully synchronised audio/video in real-time over a network or the Internet without needing to connect them directly to a computer. UBox includes software designed to identify, access, configure, upgrade and secure each UBox unit on the network as needed. Once the soft-

ware is installed and the UBox is configured, it runs seamlessly in the background allowing USB equipment to be automatically connected to PCs in the same manner as if they were connected locally.



UBox 2100 includes an Auto-Connect feature that automatically connects and disconnects shared USB printers based on need. UBox enables a PC to connect to the printer when it needs to print, then automatically disconnects when the job is finished, freeing the printer

for other users. Flexible network configuration options make it easy to use the UBox in local area networks (LANs) or wide area networks (WANs). Rather than require administrators to install drivers on each computer when each UBox is added, its Active Discovery feature automatically loads the software on each computer so that networked USB devices are available for immediate use over a LAN. For WANs, administrators can set up passwords and use static IP addresses to connect UBoxes to the network. UBox 2100 supports USB 2.0 high-speed and is housed in a ruggedised metal enclosure. It will be available globally through Lantronix channel and other sales partners for \$154 US MSRP.

www.lantronix.com

(070723-V)

Nepcon UK celebrates 40th anniversary with additional exhibitor benefits for 2008 event

In 2008 Nepcon, the complete electronics production line event for the UK and Ireland, will celebrate 40 years as the flagship event of the electronics community. As preparations for the 2008 show gain momentum, the Nepcon team announces significant additional benefits for exhibitors to celebrate this milestone event. These benefits are being offered following extensive discussions with customers and negotiations with the NEC. As a result exhibitors from last year’s event can save money by taking advantage of ‘priority booking’, with prices held at the 2007 rate until the 31st October. Free lifting and storage will be available to all exhibitors, helping to reduce costs and post-show invoices and there will be a 10% reduction on 2007 prices for service charges on electricity, air and water — making the running of machinery more cost effective. In 2008, exhibitors will also benefit from a three day build period, making it easier for companies with large equipment to set-up and avoiding expensive Sunday freight deliveries. Furthermore, the Nepcon team is delighted to announce that following negotiations with the NEC there will no longer be an £ 8.00 parking fee, making parking free for all who attend Nepcon 2008. For further details on exhibiting call Louise Conway on (+44) (0)20 8910 7706 or email lynda@consortiopr.co.uk.



to set-up and avoiding expensive Sunday freight deliveries. Furthermore, the Nepcon team is delighted to announce that following negotiations with the NEC there will no longer be an £ 8.00 parking fee, making parking free for all who attend Nepcon 2008. For further details on exhibiting call Louise Conway on (+44) (0)20 8910 7706 or email lynda@consortiopr.co.uk.

www.nepcon.co.uk
www.consortiopr.co.uk

(070819-IV)

FMicro NTC Thermistor Sensors for catheter/medical Applications

SeMitec's newest product is a micro thermistor sensor designed primarily for use in medical applications.

Using FT thin-film technology combined with laser-trimming techniques, the Fmicro thermistor sensor is only 0.5 mm diameter

by 2.3 mm long. The Fmicro is based on one of SeMitec's smallest FT thermistors encapsulated in a polyamide tube and fitted with 38AWG insulated leads.

The Fmicro is accurate to ± 0.2 K at 37 °C and is small enough to be incorporated within a catheter

probe for internal body temperature measurement. The operating temperature range is -10 to +70 °C.

www.atcsemitec.co.uk

(070819-III)

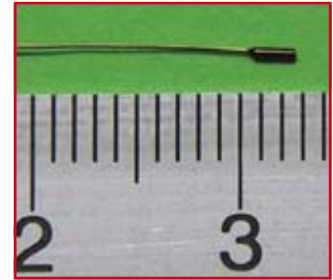

Flowcode for Atmel AVR micros



Those of you who have been following the evolution of Flowcode and E-blocks will be aware that all of this technology is based only on the 16 and 18 series of PICmicro microcontrollers. Not any more! Now there is a new version of Flowcode which generates code for the popular Atmel AVR series of microcontrollers.

The new version of Flowcode works with the Atmega and Attiny range of chips. Here's a list of the chips that are supported:

ATmega16, ATmega324P, ATmega8515, ATtiny24, ATtiny45,

ATmega162, ATmega328P, ATmega8535, ATtiny25, ATtiny461, ATmega164P, ATmega48, ATmega88, ATtiny26, ATtiny84, ATmega168, ATmega644, ATtiny13, ATtiny261, ATtiny85, ATmega32, ATmega8, ATtiny2313, ATtiny44, ATtiny861

The support for AVR is complete:

- All of Flowcode's internal components like LCD, CAN bus, internet, IrDA etc. are supported, and all of the E-blocks 'downstream' boards are compatible with the Flowcode routines.

- You can use the new version of Flowcode with any AVR programming hardware or you can develop systems based on the E-blocks AVR multiprogrammer.

- Flowcode supports on-screen simulation of systems based on the Atmel AVR processor as you can see in the screen image on the right.

- Any programs you have written for the PICmicro microcontroller using Flowcode will also transfer to the AVR microcontroller with ease.

As a special opening offer to Elektor's AVR orientated readers we are making a bundle of Flowcode for AVR Professional and a selection of E-blocks available at a discount of 30% off the retail price.

Further details in the E-blocks section at

www.elektor.com/shop

(070819-II)

PICmicro and PIC are trademarks of Microchip Technology Inc. EGo and EBlocks are trademarks of Matrix Multimedia Limited.

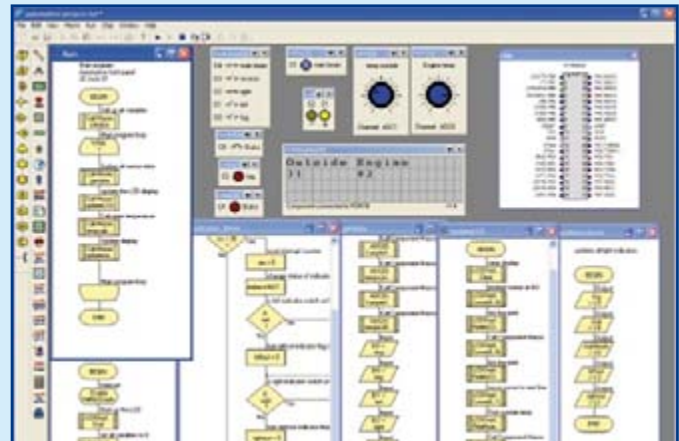

32-Channel, 1-GHz Logic Analyser

The LA-Gold-36 now in stock at The Debug Store is a high performance logic analyser with an integrated pattern generator. It was designed to be of superior technical quality to ensure measurements of excellent signal integrity. With class-leading specifications, it offers a comprehensive digital debugging environment for the electronics professional.

The LA-Gold-36 has a large data buffer of 1 megasamples per

channel for sampling rates of up to 1 GHz on all 32 channels. The large buffer allows long capture times at high sampling rates. The digital logger function is for capturing very slow varying signals, e.g. room temperature.

The LA-Gold-36's integrated pattern generator can be used in conjunction with the logic analyser. The user can set up the instrument to output data to the unit un-

der test (UUT) with the pattern generator and then measure its response with the logic analyser.

The LA-Gold-36 connects to the PC via USB2.0 for rapid display updates.

www.TheDebugStore.com



(070819-VI)



Low-cost ZigBee Antennas

choice of configuration options. Both series of antennas are suitable for use with any IEEE 802.15.4 standard 2.4-GHz ZigBee wireless system, and can accommodate vertically and horizontally polarised signals. Typical ZigBee wireless applications include environmental monitoring and control in homes and buildings, and low-speed data acquisition from remote sensors in industrial process control systems. The CTI-SB series of stubby ZigBee antennas comprises three models, with a choice of straight and right-angle SMA male and SMA male RS connectors. For applications that demand increased signal

strength, the slightly longer CTI-RA series of rubber ZigBee antennas provide a gain of up to 9 dBi. These antennas employ co-linear elements (contained within a robust, semi-flexible rubber housing) to maximise RF efficiency, and feature an integral swivel joint to facilitate orientation. The CTI-RA series offers a choice of SMA male RS and TNC male RS connectors. For designers of ZigBee systems intended for operation in the 868 MHz European or 915 MHz American ISM bands, CTi has a large selection of embedded and peripheral GSM antennas that operate at these frequencies. The compa-

ny also offers a range of adaptor cables which simplify system integration significantly; they are particularly useful for connecting the type of sub-miniature U.FL or W.FL connectors commonly used on pre-assembled ZigBee modules to external antenna. All CTi ZigBee antennas feature high-quality gold-plated connector pins to ensure signal integrity, have a nominal 50 ohms output impedance, and exhibit an output VSWR (Voltage Standing Wave Ratio) of less than 2:1.

www.cti-int.com

(070819-V)

CTi Ltd. launched two new series of low-cost ZigBee antennas which provide designers with a wide

Non-volatile Digital Potentiometers With SPI Interface

Microchip announces the MCP4141/2 and MCP4241/2 non-volatile digital potentiometers. The new 7- and 8-bit devices have an SPI interface and are specified over an extended temperature range of -40 to +125 degrees Celsius.

Unlike mechanical potentiometers, the MCP41XX/42XX devices can be controlled digitally, via an SPI interface. This can increase system accuracy, flexibility and manufacturing throughput, while decreasing manufacturing costs. Non-volatile memory enables the devices to retain their settings at power down, and their low static current consumption of just 5 µA maximum helps to extend battery life. The



MCP41XX/42XX digital potentiometers are ideal for a wide range

of trimming, calibration, set-point, offset-adjust, signal conditioning

and control applications. The MCP4141/2 digital potentiometers are available in 8-pin SOIC, MSOP, PDIP and 3x3 mm DFN packages. The MCP4241 is available in 14-pin SOIC, PDIP and TSSOP packages, and a 10-pin 4 mm x 4 mm QFN package. The MCP4242 is available in a 10-pin MSOP and an 8-pin 3x3 mm DFN package. Samples of all the new devices are available from sample.microchip.com while production quantities can be ordered at www.microchipdirect.com.

www.microchip.com/MCP41XX
www.microchip.com/MCP42XX

(070819-VIII)

Lowest-Cost USB Data Acquisition devices from NI

Scientists, technicians, engineers and students can now take advantage of measurement-quality data acquisition and the convenience of USB plug-and-play technology at a lower cost with the new National Instruments USB-6008 and USB-6009 data acquisition (DAQ) devices.

Starting at just £95 or €145 the new USB DAQ devices offer small size and easy connectivity, making them ideal for operations such as data logging and environmental monitoring. They also are useful in academic settings and are inexpensive enough for students to purchase and use in lab experi-

ments. Both devices ship with free, ready-to-run data-logging software that engineers and students can use to begin taking measurements within minutes.

The NI USB-6008 and NI USB-6009 DAQ devices deliver multifunction capabilities with eight channels of 12- or 14-bit analogue input, two analogue outputs, 12 digital I/O lines and one counter. Both devices draw power from the USB bus, so they do not require an external power supply to operate. They include removable screw terminals for direct signal connectivity, an onboard voltage reference for powering external devices and sensors, a four-layer board design

for reduced noise and improved accuracy and overvoltage protection on analogue input lines up to ±35 V. In addition to ready-to-run data-logging software, each device includes NI-DAQmx Base measurement services driver software for programming the device in LabVIEW or C.

Elektor readers can learn more about the new USB products as well as a full range of M Series multifunction DAQ devices, at the website below.

www.ni.com/daq

(070819-VII)



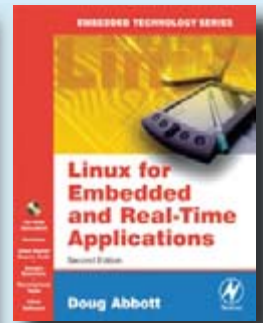
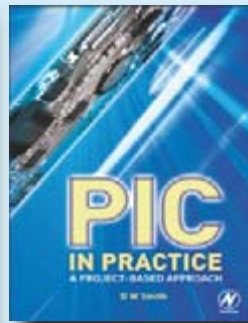
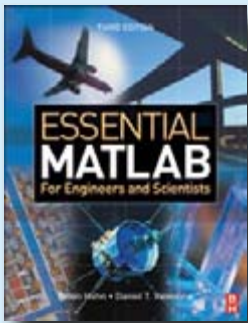

A little light reading

Elsevier Ltd. has a wide range of books of interest to electronics engineers, designers and enthusiasts, particularly those into PIC software development. A selection of relevant new releases is listed here along with their ISBN codes.

Audio Power Amplifier Design Handbook
(9780750680721)

Designing Embedded Systems with PIC Microcontrollers
(9780750667555)

Essential Matlab for Engineers and Scientists
(9780750684170)

Interfacing PIC Microcontrollers
(9780750680288)

Linux for Embedded and Real-time Application
(9780750679329)

PIC Basic Projects
(9780750668798)

PIC in Practice
(9780750668262)

Practical Electronics Handbook
(9780750680714)

Practical RF Handbook
(9780750680394)

Robot Builders Cookbook
(9780750665568)

(070819-1)

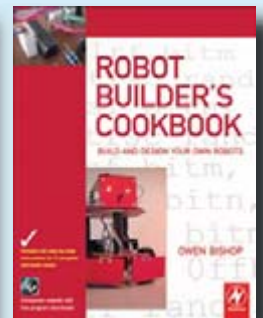
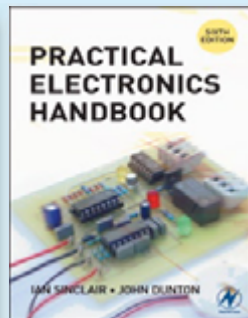
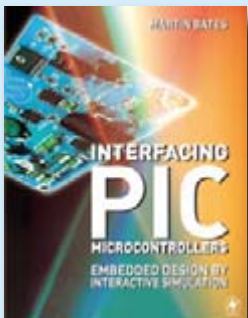

Boards for PIC, ARM and Embedded Linux

SK Pang Electronics announce three new products. The SB-C65EC is an embedded (PIC based) Single Board Computer with 10 Mbs Ethernet and RS232 interface. It can be added to any 10/100Mbs Ethernet network. It is programmed with a bootloader and a free SBC65EC Web Server. Configuration, control and monitoring can be done via a web based

interface, HTTP CGI commands or UDP commands. It has 32 general purpose I/O ports, of which 12 are 10-bit ADC (analog to digital) inputs, and 4 are 10-bit PWM (Pulse Width Modulator) outputs. The FOXLX32 is a complete Linux system in just 66 x 72 mm. The Fox board runs a real Linux operating system (not a uC Linux) on an ETRAX 100LX microproces-

sor, a 100 MIPS RISC CPU made by Axis. The FOX Board has two main field applications: as a stand alone device to build a micro web server or other network devices as proxy, router, firewall, etc. As a core engine to plug onto the PCB of a user application board instead of a simple microcontroller. For ARM7 development systems, there's a range of Atmel's SAM7

and NXP's LPC microcontroller boards. These feature from 32 kbyte to 2 Mbyte flash and from 8 kbyte to 1 Mbyte SRAM. All boards are compatible with the ARM-USB-TINY JTAG programmer making them ideal for prototype development and educational use.

www.skpang.co.uk

(070819-X)





PICFlash

with mikroCD support

PICFlash programmer – an ultra fast USB 2.0 programmer for the PIC microcontrollers. Continuing its tradition as one of the fastest PIC programmer on the market, a new PICFlash with the mikroCD now supports more PIC MCUs giving developer a wider choice of PIC MCU for further prototype development.

mikroCD debugger enables you to execute mikroC / mikroPascal / mikroBasic programs on the host PIC microcontroller and view variable values, Special Function Registers (SFR), memory and EEPROM while the program is running.

LvPICFlash

with mikroCD support

LvPICFlash programmer – an ultra fast USB 2.0 programmer for the PIC24 / dsPIC33 MCUs. A new LvPICFlash with the mikroCD now supports more MCUs giving developer a wider choice of PIC24 / dsPIC33 MCU for further prototype development.

mikroCD debugger enables you to execute mikroC / mikroPascal / mikroBasic programs on the host PIC24 / dsPIC33 microcontroller and view variable values, Special Function Registers (SFR), memory and EEPROM while the program is running.

dsPICFlash

with mikroCD support

dsPICFlash programmer – an ultra fast USB 2.0 programmer for the dsPIC30 microcontrollers. Continuing its tradition as one of the fastest dsPIC30 programmer on the market, a new dsPICFlash with the mikroCD now supports more dsPIC30 MCUs giving developer a wider choice of dsPIC30 MCU for further prototype development.

mikroCD debugger enables you to execute mikroC / mikroPascal / mikroBasic programs on the host dsPIC30 microcontroller and view variable values, Special Function Registers (SFR), memory and EEPROM while the program is running.

- All of our products are shipped in special protective boxes.
- On-line secure ordering provides fast and safe way of buying our products.

EasyPIC4 Development Board

Complete Hardware and Software solution with on-board USB 2.0 programmer and mikroCD



Following the tradition of its predecessor EasyPIC3 as one of the best PIC development systems on the market, the EasyPIC4 has more new features for the same price. The system supports 8-, 14-, 18-, 20-, 28- and 40- pin PIC microcontrollers (it comes with the PIC18F877A). The mikroCD (In-circuit Debugger) enables very efficient debugging and fast prototype developing. Examples in C, BASIC and Pascal language are provided with the board.

LV24-33 Development Board

Complete Hardware and Software solution with on-board USB 2.0 programmer and mikroCD

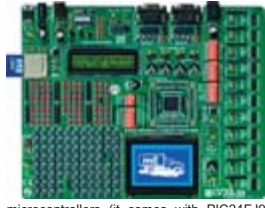

The system supports 64-, 80- and 100- pins PIC24F/24H/dsPIC33F microcontrollers (it comes with PIC24FJ96GA010 - PIC24 16-bit Microcontroller, 96 KB Flash Memory, 8 KB RAM in 100 Pin Package). Examples in BASIC, PASCAL and C are included in the system. You can choose between USB and External Power supply. LV 24-33 has many features that make your development easy. Explore new PIC24F/24H/dsPIC33F PIC MCUs with LV 24-33 and experience all advantages of these microcontrollers.

PICPLC16B Development Board

Complete Hardware and Software solution with on-board USB 2.0 programmer and mikroCD

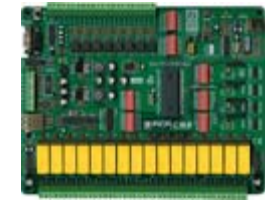

PICPLC16B is a system designed for controlling industrial systems and machines. 16 inputs with optocouplers and 16 relays (up to 10A) can satisfy many industrial needs. The ultra fast mikroCD (In-circuit Debugger) enables very efficient debugging and faster prototype development. Features : RS485, RS232, Serial Ethernet, USB 2.0 on-board programmer and mikroCD (In-Circuit Debugger) on-board.

ARMFlash



ARMFlash programmer – ARMFlash is an USB 2.0 programmer for the ARM family of Philips' microcontrollers. Very fast and easy to connect on the Board, it can program all the Philips ARM microcontrollers. You get the USB programmer which doesn't use boot loader or any similar way of programming. The whole ARM memory and all pins are available to you. Besides, you will have the state-of-the-art fast USB 2.0 ARM programmer for your future projects.

8051prog2



8051prog2 programmer – an ultra fast USB 2.0 programmer for the Atmel 8051 microcontrollers. When connected to device or development system, it becomes an IN-SYSTEM programmer. When plugged in ZIF socket, it becomes a standard programmer. You can order an optional ZIF socket, used for high volume production only. One of the possibilities of connecting 8051prog2 to the microcontroller is via an IDC10 connector. The 8051prog2 can also program the latest models.

mikroElektronika manufactures competitive development systems. We deliver our products across the globe and our satisfied customers are the best guarantee of our first-rate service. The company is an official consultant on the PIC microcontrollers and the third party partner of Microchip company. We are also an official consultant and the third party partner of Cypress Semiconductors since 2002 and official consultant of Philips Electronics company as well. All our products are RoHS compliant.

<http://www.mikroe.com/en/distributors/>

Find your distributor: UK, USA, Germany, Japan, France, Greece, Turkey, Italy, Slovenia, Croatia, Macedonia, Pakistan, Malaysia, Austria, Taiwan, Lebanon, Syria, Egypt, Portugal, India, Thailand, Slovak Republic, Czech Republic.

Uni-DS 3 Development Board

with on-board USB 2.0 programmer



The system supports PIC, dsPIC, AVR, 8051, ARM and PSoC microcontrollers with a large number of peripherals. In order to continue working with a different chip in the same development environment, you just need to switch a card. **UNI-DS3** has many features that make your development easy. You can choose between USB or External Power supply. Each MCU card has its own USB 2.0 programmer!

EasydsPIC4 Development Board

Complete Hardware and Software solution with on-board USB 2.0 programmer and mikroCD



The system supports 18-, 28- and 40-pin microcontrollers (it comes with the dsPIC30F4013 general purpose microcontroller with internal 12-bit ADC). **EasydsPIC4** has many features that make your development easy. Many of these already made examples in C, BASIC and PASCAL language guarantee successful use of the system. The ultra fast on-board programmer and mikroCD (In-circuit Debugger) enables very efficient debugging and fast prototype developing.

EasyARM Development Board

with on-board USB 2.0 programmer



EasyARM board comes with the Philips LPC2214 microcontroller. Each jumper, element and pin is clearly marked on the board. It is possible to test the most of industrial needs on the system: temperature controllers, counters, timers etc. **EasyARM** has many features making your development easy. One of them is on-board USB 2.0 programmer with automatic switch between 'run' and 'programming' mode. Examples in C language are provided with the board.

EasyAVR5 Development Board

with on-board USB 2.0 programmer



The system supports 8, 14, 20, 28 and 40 pin microcontrollers (it comes with ATMEGA16). Each jumper, element and pin is clearly marked on the board. It is possible to test the most of industrial needs on the system: temperature controllers, counters, timers etc. **EasyAVR5** is an easy-to-use Atmel AVR development system. On-board USB 2.0 programmer makes your development easy. Examples in BASIC and Pascal language are provided with the board.

Easy8051B Development Board

with on-board USB 2.0 programmer



System is compatible with 14, 16, 20, 28 and 40 pin microcontrollers (it comes with AT89S253). Also there are PLCC44 and PLCC32 sockets for 32 and 44 pin microcontrollers. **USB 2.0 Programmer** is supplied from the system and the programming can be done without taking the microcontroller out.

LV 18FJ Development Board

Complete Hardware and Software solution with on-board USB 2.0 programmer and mikroCD

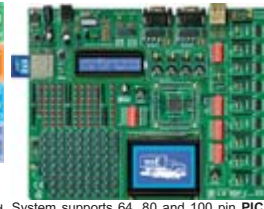

System supports 64, 80 and 100 pin PIC18FxxJxx microcontrollers (it comes with PIC18F87J60 - PIC18 Microcontroller with an integrated 10Mbps Ethernet communications peripheral, 80 Pin Package). **LV 18FJ** is easy to use Microchip PIC18FxxJxx development system. **USB 2.0** on-board programmer with mikroCD (In-Circuit Debugger) enables very efficient debugging and faster prototype development. Examples in C, BASIC and Pascal language are provided with the board.

dsPICPRO 3 Development Board

Complete Hardware and Software solution with on-board USB 2.0 programmer and mikroCD



The system supports dsPIC microcontrollers in 64- and 80-pins packages. It is delivered with the dsPIC30F014A microcontroller. **dsPICPRO3** development system is a full-feature development board for the Microchip dsPIC MCU. dsPICPRO3 board allows microcontroller to be interfaced with external circuits and broad range of peripheral devices. This development board has an on-board USB 2.0 programmer and integrated connectors for MMC/SD memory cards, 2 x RS232 port, RS485, CAN, on-board ENC28J60 Ethernet Controller, DAC, etc.

BIGPIC4 Development Board

Complete Hardware and Software solution with on-board USB 2.0 programmer and mikroCD



Following the tradition of its predecessor **BIGPIC3** as one of the best 80-pin PIC development systems on the market, the **BIGPIC4** has more new features for the same price. System supports the latest 64- and 80-pin PIC microcontrollers (it is delivered with PIC18F8520). Many of these already made examples guarantee successful use of the system. Ultra fast on-board programmer and mikroCD (In-circuit Debugger) enables very efficient debugging and faster prototype developing. Examples in C, BASIC and Pascal language are provided with the board.

BIGAVR Development Board

with on-board USB 2.0 programmer

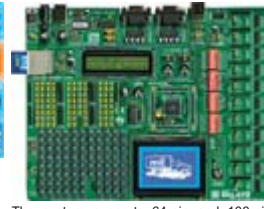

The system supports 64-pin and 100-pin AVR microcontrollers (it is delivered with ATMEGA128 working at 10MHz). Many already made examples guarantee successful use of the system. **BIGAVR** is Atmel AVR development system which is easy to use. **BIGAVR** has many features that makes your development easy. You can choose between USB or External Power supply. **BIGAVR** also supports Character LCD as well as Graphic LCD.

EasyPSoC3 Development Board

with on-board USB 2.0 programmer



The system supports 8-, 20-, 28- and 48-pin microcontrollers (it comes with CY8C27843). Each jumper, element and pin is clearly marked on the board. The **EasyPSoC3** is an easy-to-use PSoC development system. On-board USB 2.0 programmer provides fast and easy in-system programming.

Please visit our web page for more info <http://www.mikroe.com>

SOFTWARE AND HARDWARE SOLUTIONS FOR EMBEDDED WORLD



DAC Board



The MCP4921 is DAC with SPI interface that provide high accuracy and low noise performance for industrial applications where calibration or compensation of signals.

ADC with VREF



The MCP3204 is 4-Channel 12 Bit A/D Converter with SPI Serial Interface. There is 4.096V voltage reference on-board.

CAN-1 Board



The MCP2551 is High-Speed CAN Transceiver. It is used with MCUs that have integrated CAN module.

CANSPI Board



The MCP2551 Stand Alone CAN Controller with SPI Interface. This board is used with MCUs that have SPI module.

IrDA Board



The MCP2155 is IrDA Standard Protocol Stack Controller that is easy to use for implementing IrDA standard wireless connectivity.

Compact Flash Board



Easy way to use the Compact flash in your design and data acquisition. Record and analyze the information received by the MCU.

RS485 Board



The LTC485 is a low power differential bus line transceiver designed for multipoint data transmission standard RS485 applications.

Accel. Board



The ADXL311 is a low cost, low power, complete dual-axis accelerometer with signal conditioned voltage outputs. Board contains an operational amplifier.

IrDA2 Board



The MCP2120 is Infrared Encoder / Decoder. This board also contains TFDU4101 (Infrared Transceiver Module).



LCD Adapter - Connect your LCD (4x20 or 2x16) easily and save MCU pins.
GLCD 240x64 Adapter - Connect your T6963C (Toshiba) 240x64 GLCD easily.
GLCD 128x64 Adapter - Connect your 128x64 GLCD easily and save MCU pins.
GLCD 240x128 Adapter - Connect your T6963C (Toshiba) 240x128 Graphic LCD easily.

RTC Board



The PCF8583 is a clock/calendar with I2C bus interface. Keep track of the current time even when the MCU is turned off.

EEPROM Board



EEPROM is typically used to store prototype configuration parameters. AT24C02 is EEPROM with I2C bus interface.

MMC/SD Board



MMC card is used as storage media for a portable device, in the form that can easily be removed for access by a PC.

Serial Ethernet Board



ENC28J60 is a 10BASE-T stand alone Ethernet Controller with on board MAC & PHY, 8 Kbytes of Buffer RAM and an SPI interface.



Serial LCD/GLCD Adapter - Connect your GLCD and LCD (4x20 or 2x16) easily and save MCU pins.
Serial LCD Adapter - Connect your LCD (4x20 or 2x16) easily and save MCU pins.
Serial GLCD 240x128 Adapter - Connect your T6963C (Toshiba) 240x128 Graphic LCD easily.
Serial GLCD 240x64 Adapter - Connect your T6963C (Toshiba) 240x64 Graphic LCD easily.

EasyInput Board



DIP switch is designed to be used on a printed circuit board along with other electronic components and is commonly used to customize the behavior.

DIP to PLCC44 Board



Professional and production adapter allows easy and fast working. You will have to press the PIC into the adapter.

Port Expander Board



MCP23S17 is the only 16-bit Input / Output expander that features SPI(tm) clock speeds up to 10 MHz for higher throughput applications.

PIC Experimental Board



High Quality PIC Experimental board enables you to program microcontroller unit with ease. There are 8, 10, 14, 18, 28 and 40 pin DIP sockets.

3.3VReg Board



Voltage regulator specifically designed for use in low input voltage applications. This regulator can provide regulation changing your voltage from DC 5V to 3.3V.

EasyPROTO Board



Connects your prototype board with high quality IDC10 connector.

5V-3.3VReg Board



This regulator can provide local on-card regulation changing your voltage from AC/DC 8-16V to 5V or 3.3V.

EasyConnect Board



Connects your peripherals easy and fast using high quality on-board connectors. Useful in power as well as high-speed signal-handling applications.

Keypad 4x4 Board



Keypad can also be integrated as part of prototype that contains a calculator-style arrangement of buttons.

Digital POT Board



Digital Potentiometer with MCP41010 SPI interface single-channel digital potentiometer on board. Set potentiometer values from 0 ... 10 kohm.

EasyMP3 Board



Add MP3 to your prototype with VS1001k MPEG audio layer 3 decoder with SPI Interface. Screw terminal for easier connection with the external peripherals.

SmartMP3 Board



Add MP3 to your prototype with VS1001k MPEG audio layer 3 decoder with SPI Interface. Low Voltage Audio Power Amplifiers and Voltage Level Selection - 5V or 3.3V.

PIC-Ready Board



High Quality prototype board with extension pin headers for 40 and 28 pin mcu will give you easiness of programming microcontroller unit.

Light to Freq. Board



Add light to frequency converter to your prototype with TSL230BR programmable light-to-frequency converter on board.



A beginner? Don't worry. Easy-to-learn BASIC syntax, advanced compiler features, built-in routines, and many practical examples provided allow a quick start in programming PIC. mikroBasic for PIC has many routines and examples such as EEPROM, FLASH and MMC, SD and CF cards support, writing character and graphics on LCDs, push-buttons operations, 4x4 keyboard and PS/2 input, generation of signals and sounds, character string tools, math calculations, I2C, SPI, RS232, CAN, USB, RS485 and OneWire comm., Manchester coding, numerical conversion, PWM, interrupts, etc.



Comprehensive, stand-alone Pascal compiler for the PIC MCUs. Develop your applications in an intuitive and friendly Pascal environment, using many advanced features and practical examples for PIC. mikroPascal for PIC has many routines and examples such as EEPROM, FLASH and MMC, SD and CF cards support, writing character and graphics on LCDs, push-buttons operations, 4x4 keyboard and PS/2 input, generation of signals and sounds, character string tools, math calculations, I2C, SPI, RS232, CAN, USB, RS485 and OneWire comm., Manchester coding, numerical conversion, PWM, interrupts, etc.



The power and flexibility provided by ANSI C, with the most advanced IDE on the market. The perfect match. Plenty of practical examples and comprehensive documentation. The mikroC for PIC has many routines and examples such as EEPROM, FLASH and MMC, SD and CF cards support, writing character and graphics on LCDs, push-buttons operations, 4x4 keyboard and PS/2 input, generation of signals and sounds, character string tools, math calculations, I2C, SPI, RS232, CAN, USB, RS485 and OneWire communication, Manchester coding, numerical conversion, PWM, interrupts, etc.



A beginner? Don't worry. Easy-to-learn BASIC syntax, advanced compiler features, built-in routines, and many practical examples provided allow a quick start in programming dsPIC30/33 and PIC24. mikroBasic for dsPIC30/33 and PIC24 has many routines and examples such as EEPROM, FLASH and MMC, SD and CF cards support, writing character and graphics on LCDs, push-buttons operations, 4x4 keyboard and PS/2 input, generation of signals, character string tools, math calculations, I2C, SPI, RS232, CAN, RS485 and OneWire comm., Manchester coding, numerical conversion, PWM, interrupts, etc.



Comprehensive, stand-alone Pascal compiler for dsPIC30/33 and PIC24 MCUs. Develop your applications in an intuitive and friendly Pascal environment, using many advanced features and practical examples for dsPIC30/33 and PIC24. mikroPascal for dsPIC30/33 and PIC24 has many routines and examples such as EEPROM, FLASH and MMC, SD and CF cards support, writing character and graphics on LCDs, push-buttons operations, 4x4 keyboard and PS/2 input, generation of signals and sounds, character string tools, math calculations, I2C, SPI, RS232, CAN, RS485 and OneWire comm., Manchester coding, numerical conversion, PWM, interrupts, etc.



The power and flexibility provided by ANSI C, with the most advanced IDE on the market. The perfect match. Plenty of practical examples and comprehensive documentation. The mikroC for dsPIC30/33 and PIC24 has many routines and examples such as EEPROM, FLASH and MMC, SD and CF cards support, writing character and graphics on LCDs, push-buttons operations, 4x4 keyboard and PS/2 input, generation of signals and sounds, character string tools, math calculations, I2C, SPI, RS232, CAN, USB, RS485 and OneWire comm., Manchester coding, numerical conversion, PWM, interrupts, etc.



A beginner? Don't worry. Easy-to-learn BASIC syntax, advanced compiler features, built-in routines, and many practical examples provided allow a quick start in programming AVR. mikroBasic for AVR has many routines and examples such as EEPROM, FLASH and MMC, SD and CF cards support, writing character and graphics on LCDs, push-buttons operations, 4x4 keyboard and PS/2 input, generation of signals and sounds, character string tools, math calculations, I2C, SPI, RS232, CAN, USB, RS485 and OneWire comm., Manchester coding, numerical conversion, PWM, interrupts, etc.



Comprehensive, stand-alone Pascal compiler for AVR MCUs. Develop your applications in an intuitive and friendly Pascal environment, using many features and practical examples for AVR MCU. mikroPascal for AVR has many routines and examples such as EEPROM, FLASH and MMC, SD and CF cards support, writing character and graphics on LCDs, push-buttons operations, 4x4 keyboard and PS/2 input, generation of signals and sounds, character string tools, math calculations, I2C, SPI, RS232, CAN, USB, RS485 and OneWire comm., Manchester coding, numerical conversion, PWM, interrupts, etc.

Please visit our web page for more info <http://www.mikroe.com>

SOFTWARE AND HARDWARE SOLUTIONS FOR EMBEDDED WORLD

Reflow Solder Controller

Soldering SMDs in an ordinary electric oven

Paul Goossens

The Elektor lab needs to solder SMDs more often these days, something that undoubtedly also applies to many of our readers. In the January 2006 issue we described in some detail how you could build your own reflow oven using an inexpensive electric oven. That article resulted in many enthusiastic comments from our readers, which confirmed to us that there was a lot of interest in such a project. In this issue we present a completely new version of the control electronics for a DIY SMD oven. It is even available as a kit of parts, making the construction easy provided you know your bit about electrical safety regulations.

Our reflow oven is still used regularly in the Elektor lab two years since. As a result of the feedback from our readers we thought it was a good idea to come up with a more repeatable version of this project, and make it available as a kit of parts. This should enable many of our readers, we hope, to construct their own SMD reflow oven.

For those of you who have not read the original article we shall first take a closer look at the reflow process.

The end of the soldering iron?

Conventional soldering is usually done with a soldering iron. Here you first heat up the parts with the soldering iron. Once the temperature is high enough you apply a bit of solder. This will melt and bond the two parts together. The result is (hopefully) a good solder joint.

This method is just perfect for use with conventional electronic components, since the connections are heated up

one at a time and the chip itself remains relatively cool.

A limitation of this method is that both parts to be soldered have to be accessible to the soldering iron tip. With many SMDs (surface mount devices) this is difficult and with others it's completely impossible!

Reflow

One of the methods used for soldering these components is called reflow soldering. Instead of heating the parts with a soldering iron, with this method the whole board, including all components, is heated!

Standard solder is no longer used here; instead, use is made of a substance called solder paste. This grey material consists of extremely fine grains of solder mixed with flux. This paste is first applied to the pads on the board. The components are then placed on top of this. Everything then goes into the oven, where it is heated until the sol-

der starts to melt and joins the component leads to the pads.

Temperature profile

This sounds simple, so why would we need a Reflow Controller circuit? An ordinary oven should be able to do this job just fine!

The reason is that for the soldering process to complete successfully, the board has to be heated and cooled fairly accurately in a certain amount of time. **Figure 1** shows a measured temperature curve.

The process begins with the 'Pre-heat' phase. Here the temperature in the oven is increased to about 125 °C. At this temperature the flux becomes liquid. The excess flux will flow away from the pads, leaving the grains of solder behind.

The temperature then rises relatively slowly to 175 °C. This temperature is close to the melting point of the grains of solder. The reason for the gradual



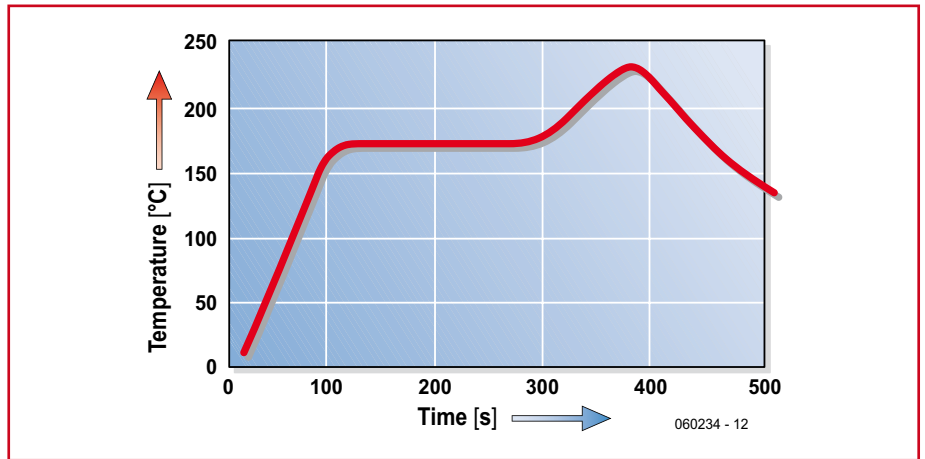

Figure 1. Temperature characteristic measured inside the oven.

rise of the temperature is that the board and the components need time to end up at the same temperature. In reflow terminology this is known as the 'Soak' phase.

Once this temperature is reached, the oven has to heat up the board and components to the maximum temperature (usually 220-240 °C). During this phase (called 'Reflow') the grains of

solder melt and bond to the surrounding metal. The solder joint is now effectively made. After the maximum temperature has been reached, everything needs to

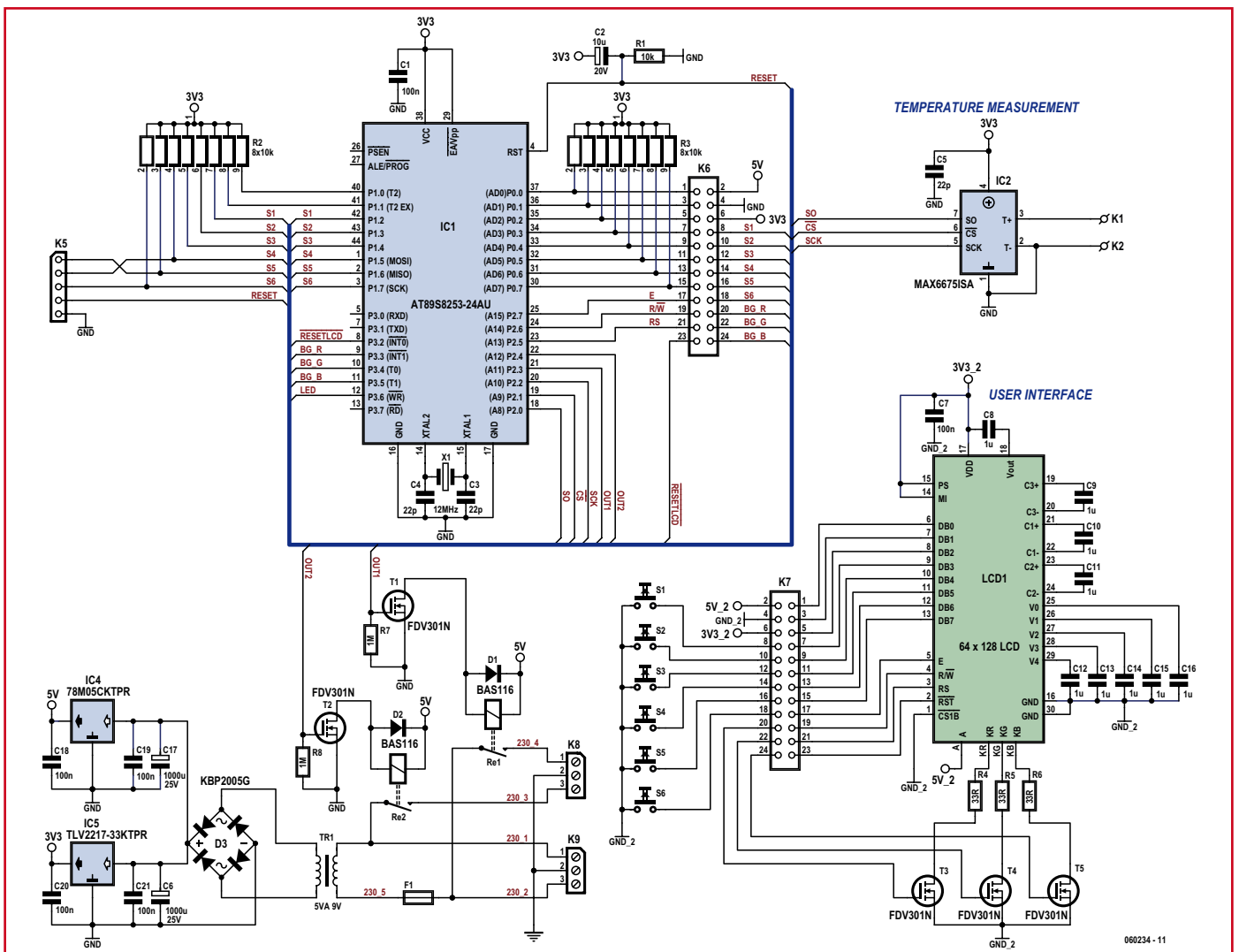

Figure 2. Circuit diagram for the Reflow Controller.



Figure 3. A quick look inside the box.

cool down again. This phase has the unequivocal name of 'Cooling'. However, this cooling shouldn't happen too quickly; again this is to avoid large temperature differences between the board and components. Otherwise they may still deform or even break! On the other hand, the cooling shouldn't happen too slowly, especially at the beginning. Some components can only stay above a critical temperature for a limited amount of time!

Lead versus lead-free

Broadly speaking, solder pastes can be divided into two groups, based on the composition of the solder. The metal used in solder is an alloy consisting of two or more metals.

With most of the lead-based solder pastes this is an alloy of tin and lead (SnPb). This alloy has a melting point of 183°C.

The second group, the lead-free pastes, usually consist of a tin, silver and copper alloy (SnAgCu). This doesn't contain lead, which means it has a much

higher melting point. It is only at 217°C that it begins to melt.

When the latter group is used in soldering the maximum temperature in reflow soldering has to reach about 240 °C.

With lead-free pastes 220 °C is sufficient, and sometimes it even works with a maximum temperature of 200 °C. This doesn't only save time, but it also means that the components suffer less from the soldering process.

According to the new RoHS regulations it is no longer permissible for consumer electronics to contain lead-based solder, with a few exceptions such as automotive applications. Consequently, you are still allowed to use it in the lab when building one offs and prototypes. As long as the gear you build is not offered for sale there is nothing to worry about.

New design

Now that we're familiar with the 'reflow' concept it is time to take a closer look at the controller circuit.

The fact that we wanted to make this project available as a construction kit was another good reason for us to enhance the original design. At first blush there wasn't anything wrong with the first version, but we decided to modify the electronics somewhat, based on our experiences with the previous design and the feedback from our readers (thanks all for contributing to the forum topic on the 2006 oven).

From this it became clear that nobody made use of the serial port. With this port you could display the change in temperature during the reflow process on a PC. Instead of this facility we thought it would be useful to show this on the display of the controller itself.

In the new design we therefore left out the serial port and the EEPROM. We also replaced the 2×16 character LCD with a spiffy graphical display. As far as cost is concerned, it even turns out to be a bit cheaper and the end product looks a lot better.

Another change is that both solid-state relays have been replaced with conventional relays. This was also done to reduce the cost.

Circuit diagram

The circuit diagram for the controller (Figure 2) is very similar to its celebrated predecessor from 2006. At the heart of the circuit is controller IC1, an AT89S8253. In this circuit it operates at a frequency of 12 MHz.

K5 is a programming interface, which can be used to program new firmware into the controller. A simple programmer is required for this. The controller in the kit is ready programmed, so for most users this connector won't be of much interest.

The supply is taken care of by Tr1, D3, IC4 and IC5, as well as a few other components to provide smoothing. As far as the power supply is concerned, we would like to point out that the construction kit is available in two versions: one for 230 V mains (most of Europe) and the other for 115 V mains (USA and some other countries). The only difference between the two is in the mains transformer.

The mains voltage is connected via K9. This voltage is switched by relays Re1 and Re2, which in turn are driven by FETs T1 and T2. The oven is connected to K8.

The temperature is measured using a thermocouple. This is connected via a cable and latching plug to K1 and K2. IC2 performs the actual measurement.

This IC converts the thermocouple voltage into an absolute temperature that is read by the controller via P2.0, P2.1 and P2.2.

The connections for pushbuttons S1 to S6 are very simple. They are connected directly to inputs P1.2 to P1.7 of the controller. Remember that these inputs are also used during the programming of the controller. This means that you shouldn't press any of the buttons when the controller is programmed via K5! Pullup resistor R2 is used to keep the inputs at 5 V when the circuit is at rest.

The graphical LCD doesn't have many surprises. Apart from the usual LCD interface there are also a few capacitors. These are used by the onboard electronics of the LCD module to generate the extra voltages required by the LCD.

FETs T3, T4 and T5 drive the LEDs for the background lighting. In this case we decided on RGB lighting. The background light can then be given any colour by applying varying PWM signals to the three FETs.

Which oven?

Apart from the Reflow Controller board you obviously also need an oven to construct the project. It is absolutely vital that it is a **fully analogue oven with a mechanical thermostat and a mechanical clock**. It should be able reach a temperature of 225 °C, and preferably a bit higher still.

It is also advantageous if the oven has a small internal volume, as the temperature can rise more quickly in that case. A power rating of 1500 watts should be sufficient then.

In practice you should find that just about any all-analogue pizza oven or mini-oven rated at 1.5 kW would work.

With this version of the Reflow Controller it is no longer necessary to make extensive changes to the oven. You only need to mount a thermocouple inside the oven. This can be done via a small hole in the side or on a bracket inside the oven. You have to make sure that the thermocouple remains galvanically isolated from the oven itself!

The second modification is in the mains lead (cord). The normal mains lead is replaced by the lead included with the construction kit. This comes with a mains socket that fits to our Reflow Controller.

Construction and use

The construction of the Reflow Controller (**Figure 3**) is straightforward. The building is limited to screwing the different parts together and making a few connections. Full instructions are supplied with the construction kit. This manual can also be downloaded from the Elektor website. An introduction to the operation of the reflow oven is also included with this.

(060234-1)

Web Links

www.elektor.com

www.8052.com/visisp52/

Baking

Components can adsorb some moisture from the air. During normal operation this doesn't really matter, but this can cause problems with reflow soldering.

The temperature of the chip will rise above that of the boiling point for water. The moisture inside the chip will then turn into steam, which causes the pressure inside the chip to increase a fair amount. The result of this is that the chip can crack because of the presence of the steam.

When the components have been stored in humid conditions it's possible to remove the moisture from them by heating them to about 80 °C for several hours.

This is even more important when lead-free solder is used, as the pressure of the steam increases as the square of the temperature!

The Reflow Controller has a special function that performs this baking process.

Solder paste

Apart from the grouping of solder pastes into lead and lead-free there is another possible grouping based on the type of flux used. The flux can be chemically active, which requires that the board is cleaned after the soldering process to remove any remaining flux from the board. There are also types of flux that exhibit some conductivity. Keep an eye out for these!

The best pastes to use are those that have 'No-Clean' written on their label. This means that it's quite alright to leave the flux on the board after soldering. It won't corrode the board in any way, nor is the residue conductive so it won't affect the operation of the circuit.

Another point to look out for is the size of the grains of 'tin'. The smaller these grains are, the easier it is to apply small doses to the board with a syringe. The rule of thumb here is: "the smaller the better"!

Firmware

As is usually the case with Elektor projects, the firmware for the microcontroller used in this project is available as a free download from our website.

For the compiler we've used the free (!) 'SDCC' C compiler.

If you want to include some of your own ideas to the firmware in the controller, you will need a programmer as well as this compiler.

Our preferred software for this is VisISP-52. The associated programmer (which can be found on the visISP52 website [2]) is easily built on a piece of experimenter's board.

Reflow Techniques

Using the Elektor SMD Reflow Soldering Oven

Hagay Ben-Elie

There is a bit more to using reflow soldering than just popping the circuit board in the oven and setting a simple timer. Modern SMT and BGA devices require special handling and strict processes. The steps and tips described in this article will remarkably increase the rate of success in assembling such novel projects.

Tip #1: Baking and drying

The chances of hobbyists to get newly manufactured devices in their original sealed vacuum packages are not very high, to say the least. It is more likely that second hand or salvaged components are used. Even with newly bought devices there is no way to know their storage conditions prior to reaching our hands.

Components tend to absorb ambient moisture. This happens all the time, even when already assembled and soldered in the circuit. This is not a problem when manually soldering these de-

vices as heat is applied to only one lead at a time and the entire device is not overheated. However, when placed in a reflow oven and heated to about 250 °C these devices can be destroyed due to what is known as the 'popcorn effect'. Moisture, at such high temperatures, is becoming steam that erupts from the device — most likely by cracking

its case — and permanently destroying it.

The same applies to printed circuit boards (PCBs), which absorb moisture during their production (etching) stage. When significantly heated, e.g. during a reflow process, this moisture becomes steam and usually erupts from vias and through-holes (TH). When steam erupts from holes filled with melted solder, it creates bubbles in the solder joints (voids) and even worse, scatters solder balls (splashes) all around.

The best way to avoid these devastating effects is by simply drying PCBs and devices prior to being as-

sembled and reflowed. This is often called 'baking', and is done by placing them in a specially designed 'baking oven', at 100-250°C for at least six hours (or even longer). Moisture then evaporates without causing any harm to the items. Items are considered to remain 'dried' for about 48 hours, so baking/drying should be performed less than 48 hours before the reflow process.

PCBs and devices are designed to withstand higher temperatures, so there is no impact on the behaviour or characteristics of these items. This, however, cannot always be said about the containers (tubes, trays, etc.) in which these items are stored. Make sure to bake items with no 'plastics' around them! Figure 1 shows humidity recording strips for use on an FPGA device — its purpose is all to clear!

Allow for natural (not forced) cooling of items afterwards. As I don't know of any other homemade solution, the best way to bake items seems to be using the reflow oven itself. This feature was not implemented in the original (2006) version of the Elektor oven, but now it is!

The art of SMT assembly differs immensely from what we got used to doing with TH assembly.



Figure 1. Humidity indicator strips and desiccant bags should be part of your SMD reflow soldering toolkit!

Tip #2: Solder paste

Solder paste alloys are usually sold in large quantities as they are intended for industrial use. Minimum package size



Figure 2.
Not for the squeamish!
Syringes and 'guns' like the ones shown here will prove invaluable for applying solder paste on solder pads for SMD devices.

(called 'jar') is 0.5 kg (approx. 1 lb.) and that is a lot! Normal shelf life is about six months, and is achieved by storing it in a refrigerator. A normal kitchen refrigerator will do, but the jar must be adequately sealed and marked as 'non-edible substance'. It is best if kept well out of reach of other family members and especially children.

The stated shelf life is primarily intended for quality aspects during industrial use and mass production. For homemade projects, where no restrictions exist (life dependency, etc.), solder paste can be used as long as it keeps its original appearance (colour, texture, viscosity). With proper storage conditions, 3-year old compounds may still do the job.

Unless specially intended for, avoid using the new Pb-free alloys. The new RoHS directive dictates other soldering conditions for the industry — usually related to higher temperatures (up to 280°C) — which are above the rated conditions of current PCBs and components, nor are supported by the Elektor Reflow Soldering Oven.

The best normal use alloy for non-industrial use is the Sn63Pb37 (63% tin, 37% lead) compound. It is easiest to use and

gives the best results in terms of strength, appearance and conductivity. If possible select a compound with the finest granularity.

Solder paste is, in essence, a blend of tiny solder balls and active flux. If a $\times 10$ to $\times 30$ microscope is accessible these solder balls may be actually observed. 25-45 μ grains will give the best results. Refer to manufacturers' websites [1], [2] and [3] for further information.

A new solder jar is always hermetically sealed to protect it against oxidation and moisture. Check it and avoid buying opened jars (unless received free of charge...). A sealed jar must be kept at room temperature and never refrigerated.

Open the sealed jar just before using it. When re-using a refrigerated jar, remove it from the fridge at least three hours before use. Keep it tightly closed and allow it to reach room temperature before opening and using. Otherwise, condensation might affect the compound — causing bubbles in the solder joints and solder splashes all over the circuit.

Just before use, using a flat object like a knife or a spatula, gently blend compound to reach a uniform mixture. Avoid rapid stirring as this might let air to enter the compound and cause air bubbles (voids) in the final solder joints. Instead, use gentle, smooth blending — just to make sure that compound ingredients have not got separated.

Cleaning of solder paste residues (before soldering) is easily performed using Isopropyl Alcohol (IPA).

Tip #3: Visual aids

As probably understood by now, a good visual aid is a must. A minimum $\times 5$ illuminated magnifying glass or preferably a $\times 10$ (or higher) microscope might make the difference between good and poor solder joints. The bare eye can hardly locate shorts and/or bad solder joints smaller than 20 mils ($0.02'' = 0.5 \text{ mm}$).

Tip #4: Solder paste application

Solder paste must be applied to each pad on the PCB where components are to be assembled. During industrial use a special template, called stencil, is used. This is a 4-6 mils ($0.004\text{-}0.006'' = 0.10\text{-}0.15 \text{ mm}$) thick stainless steel sheet (mask), which is perforated where solder paste should be applied to the board.

Solder paste is then spread on the stencil and squeezed into these small holes. Excessive paste is removed, and when the stencil is vertically lifted off the board only small solder paste dots are left on it, as required.

This process is very expensive and, obviously, cannot be performed using our humble resources. A manual application method is more likely to be used. This is carried out by using a medical syringe as the application tool. Use a small (about 5-10 cc) syringe (Figure 2) — you'll be amazed how little material is being used. Fill it with a few drops (2-3 cc) of solder paste. Re-assemble it and connect it to a thick needle. Look for the thickest needles available — like the ones used for blood tests — and not those fine ones used for injections. Buy needles new and unused only.

Using some kind of visual aid, as mentioned above, apply small dots of solder paste to each required solder joint. Apply the smallest possible dots and try having them all in the same size. Especially keep them as uniform as possible for all joints of the same device.

Remove excessive compound using a toothpick or gently wipe it using a cotton swab/bud dipped in IPA.

Solder pastes have nominal on-board active life of about 8-12 hours. This means that the board must be reflowed within this period of time since the first dot was applied. This is

Baking/drying was not implemented in the original version of the Elektor oven, but now it is!

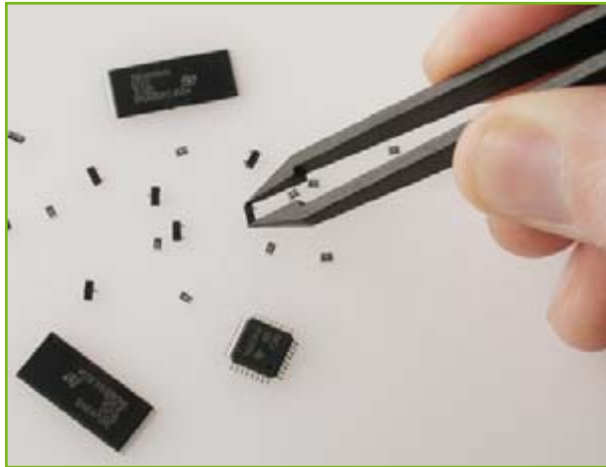

Figure 3. Special antistatic tweezers for SMDs are cheap and will not easily end up in the missus' beauty case.



no problem when only a few components are to be assembled but gets complicated for larger construction projects. Well, no one promised you a rose garden...

Tip #5: Placing the components

Automatic pick & place machines are usually beyond the reach of the home worker. Fortunately, in most cases manual placement will be as good. Small chip components (resistors, capacitors) may be placed using small tweezers (Figure 3). For larger components (ICs) a vacuum pen is recommended.

Observe orientation and polarity of devices and gently lay them in place. Don't press them down. Just let them hover on top of the solder paste dots.

This requires some practice, though, but is not so difficult to achieve. As with solder paste

application, a good visual aid is essential. Special attention should be given to precise location of the devices prior to releasing them on the board. Slight misalignments are self remedied (see below) but should be kept as small as possible. Trying to move misaligned devices will most probably cause smearing of the solder paste dots and lead to poor solder joints and a bigger chance of shorts.

For the real boffins among you, the 'BGA Challenge' is discussed in the inset.

Tip #6: Cleaning and inspection

Most modern solder pastes are defined as non-cleanable, which means that the flux residues are not conducting and may, therefore, be left on the final product. Sometimes cleaning is simply impossible, such as beneath BGA devices. Cleaning also involves hazardous materials that are harmful to the inexperienced user and may contaminate the working place as well as pollute the environment.

If, after all these warnings, cleaning is still desired, simply use the same materials and techniques as for ordinary TH soldering.

As mentioned before, inspection of the final product is crucial. Solder joints are so small and delicate that shorts and bad joints are most likely. Using a good visual aid will help locating these mishaps and manually correcting them.

Tip #7: Mixed technology double sided reflow, and some technical insights

Where both reflow and manual soldering are required (assumably most of the cases) reflow must be performed first. After all SMT/BGA devices are assembled, soldered, and checked it is easy to manually assemble and solder all other devices.

Double-sided reflow, where needed, can also be performed quite easily.

During industrial electronic assembly of double sided reflow, boards undergo this process twice: once for the secondary side (PS) and then for the primary side (CS).

During this process, the temperatures of the other side of the board are kept below solder melting point, thus not affecting the already

soldered devices.

This is not the case with the Elektor reflow oven where temperatures on both sides of the

Fortunately, in most cases manual placement will be as good as industrial pick & place.

board are likely to be the same.

To overcome this we must use a small trick. Start by reflowing only one side of the board — preferably with a smaller number of SMT/BGA devices. Wait for the board to completely cool down. Using epoxy adhesive, secure each device with a small drop or two. Larger PLCC or BGA devices might require four drops — one on each corner of the device. Apply small drops and avoid spilling on adjacent conductors or leads. This is to allow replacing devices at a later stage without endangering the board or devices. Additionally, epoxy adhesive and solder have different thermal coefficients, causing them to expand differently while heated. This might cause pads to literally be torn off the board at high temperatures.

Clean excessive adhesive and allow curing in accordance with manufacturer instructions. When completely cured, process the other side of the board if it was the only side. A common mistake is to use SMT adhesive for securing multileaded devices. This adhesive is best kept for chip components (resistors, capacitors, etc.) only. The soldering process of larger devices is obstructed if the devices can't move freely during reflow. Remember that devices need to float on top of the solder paste dots? The reason is simple. While melting, the solder dots simply collapse and cause the device to descend into place by means of the already mentioned facial tension. Each lead or ball is then contained within a small solder bead — creating a good elec-

Tip #5.1: Ball Grid Array (BGA) Masterclass

Placing a BGA (ball grid array) device is hard to perform but by no means impossible. Different BGA devices have different sizes, footprints, and balls' arrangements. Each device needs to be uniquely processed. First check that the device matches its designated footprint. Check for balls' arrangement, pad sizes and pitch (distance between two adjacent joints). If these all match then precise placing is to be determined. On commercially available PC boards, where silkscreen printing exists, check that the distance between outer rows of pads and marked rectangle equals the distance between device's outer rows of balls and its contour. Check all four directions.

When using non-marked boards, this rectangle needs to be manually drawn on the board (using an extra fine marking

pen or a very sharp pencil). Otherwise, there is no practical way to put the BGA device in place.

This stage, obviously, needs to be performed before applying solder paste to the board. As mentioned above, slight deviations (or rather misalignments) are acceptable. During normal reflow process, while solder is liquefied, the facial tension within the solder (multiplied by the number of solder joints) has enough force to pull the device into place and compensate for small placing errors.

As with other devices, use a vacuum pen to lay the device on top of the solder paste dots. Don't squeeze it. Let physics do its work.

Finally, let it be said that BGA placement and soldering is an art of itself. Even industry experts do not always succeed in achieving 100% yield and sometimes need to replace BGAs at a much higher rate than other SMD devices.

trical connection. Obviously, SMT adhesive fixes the device in one place and prevents it from "moving with the stream". The melted solder might then simply loose contact with the device's leads. When this happens to even one ball of a BGA device, where rework is impossible, the entire device may be rendered useless and needs to be completely removed from the board and replaced. An unthankful job!

Tip #8: Removal of soldered multileaded devices

If heat is used to solder these devices, why not use it for removing them?

Since we usually deal with single or double layer boards, preheating of the other side of the board is normally not required.

Multiple-layer boards usually tend to have internal discontinuities if processed without preheating since this exposes to a severe thermal shock (a significant thermal difference between both sides of the board).

An electrical heat gun, such as the one used for shrinking tubing insulation or for removing paint from walls, is the perfect tool for this task. (Don't use the open fire type as it can burn the board and devices. Don't use a hair drier, as its air stream is not hot enough). This appliance is capable of producing heat that will melt solder and that is just what it will do. Point the air stream at the device's leads and gently move it around. Avoid heating the case of the

device. After a short while all solder joints will melt and stay liquefied even when air stream is not directly pointed at them. The device is then easily lifted off the board using small tweezers. Use desoldering wick (braid) to remove any solder residues from the pads on the board.

Some final words

The art of SMT assembly differs immensely from what we got used to doing with TH assembly. Yet, it is not beyond the capabilities of the average enthusiast. Some level of experiencing is required, but come to think of it — were you successful with your very first TH solder joints?

Lets face it, TH assembly is about to go extinct for new design. In this aspect the new Elektor Reflow Soldering Oven Controller is a real leap into the future.

(070658-1)

Note. A Powerpoint presentation showing equipment used for various steps in professional SMD board production and reworking is available as a free download (# 070658-11) with this article.

Web Links

1. www.kester.com/en-US/technical/alloy.aspx
2. www.aimsolder.com
3. www.ko-ki.co.jp/product/index.html

Electrostatic Discharge (ESD) precautions

A lot was said in the past about ESD but more than ever before, these tiny creatures are susceptible to charges as small as 20 V! ESD will not always destroy the components but might rather cause latent failures that will affect their operation and significantly reduce their life expectancy. Following a few simple rules will help us to avoid such failures:

- Always keep active devices (transistors, ICs), in their ESD protective containers (trays, tubes, envelopes). Take them out only when needed.
- Avoid touching devices' leads. Always hold their cases instead.
- Use protected workstations. Desktop shall be always covered by a grounded working surface. Verify that electrical working tools — soldering irons, reflow oven, etc. — are adequately grounded. Preferably connect all of them, together with the desktop surface, to the same grounding point — in

order to minimize potential differences between them.

- Use ESD protective wrist (or heel) strap. This cheap commercially available bracelet makes an excellent protective measure, as it removes any harmful charge off our body. High quality straps are equipped with an internal 1 M Ω resistor Assuming that the most common grounding connection is the mains outlet earth terminal, this resistor protects us from the lethal voltages that may exist on power lines (or when accidentally plugging it to the mains Live terminal...).
- The wrist strap's cord is better connected to the desktop protective surface, which is ground by another connection, rather than having them both grounded together.
- And a final word about grounding the reflow oven (or at least its metal net shelf). This shelf, most likely used for placing the reflowed circuit, should be electrically isolated from the grounded case of the oven. It should, instead, be grounded via the ESD grounding regime. This is to avoid rapid discharge of the ESD susceptible devices through metal connection — another way to destroy components.

Low Cost – Low Power AVR Web Server

Holger Buss and Ulrich Radig, in collaboration with Dr. Thomas Scherer

A web server using an Atmel controller cannot be for real — or can it? Perhaps it can, because in the world of Open Source technology seemingly nothing is impossible. What's more, it's entirely feasible to cram the code required into an ATmega32. External control and connectivity for a webcam make this project even more attractive.

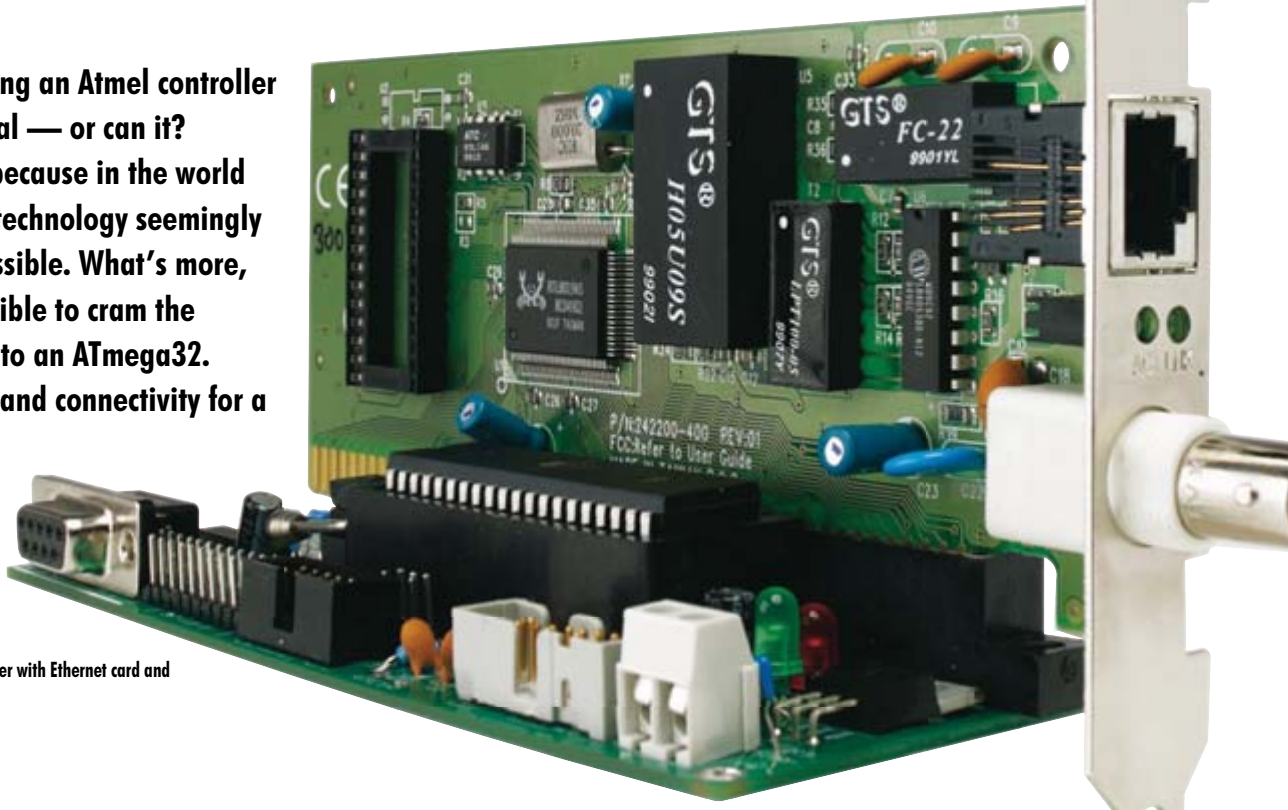

Figure 1. Completed web server with Ethernet card and serial interface.

It all began, Ulrich Radig confesses, when he wanted to switch his coffee filter machine on using the Internet. Some nifty design work resulted in a

small web server with some Ports that allowed him to control and select analogue inputs. Having launched his design on the Internet [1], he soon attracted an enthusiastic following of like-minded individuals who improved his original concept by designing a host of hardware and software add-ons. Holger Buss then designed a PCB with 'only' two sides for a hook-up that linked it up to the Internet using an old NE2000-compatible Ethernet card [2] (Figure 1). Unlike many other small server designs, this circuit didn't call for any SMDs. Ease of soldering is one advantage of that approach, along with minimal cost thanks to the use of low-budget new materials and recycled 'ancient technology' parts.

changing now as suppliers offer smaller form factors, such as housings for external hard drives that are distinguished not only by USB, eSATA or Firewire interfaces but also the three letters NAS (standing for Network Attached Storage). Part of the standard specification is a speedy controller device operating at several hundred MHz plus a slimmed down Linux operating system. Server capabilities are configurable for protocols including FTP, SMB and frequently HTTP as well, via a built-in web page. A few score megabytes of Flash and RAM are *de rigueur*.

Despite all this sophistication an ATmega32 has a mere 32 kilobytes of Flash memory and in matters of RAM you must make do with a whole 2,048 bytes! In consequence a microcontroller cycling at 16 MHz is operating at a mere fraction of the rate of an NAS controller. And despite the '32' in the ATmega32 designation, the ATmega series still uses true blue 8-bit CPUs.

Performance data

- Web server with ATmega32/ATmega644
- Current consumption <100 mA
- Polling of three analogue inputs
- 7 digital I/O lines
- 1-Wire interface (Dallas)
- Connection for webcam
- Interface for SD memory card
- Polling of an NTP time server
- Configuration by text file
- e-Mail notification
- Serial interface
- In-circuit programming
- Ethernet via NE2000-compatible ISA network card

Linux rules—or does it?

Web servers tend to be bulky and noisy, housed in 19-inch rack cabinets and using Linux or Windows as their operating system. This picture is

This harks back all too strongly of the earliest beginnings of hobby computery of at least 25 years ago, when for mega-money you could buy monster A3-size PCBs populated with Z80, 6502 or 6800 CPUs. Compared to the fearsome cost of a KIM-1, AIM-65 or even *Elektor* magazine's own modular SC/MP system (does anyone still remember this?), you can buy a significantly more powerful ATmega32 today for well under £ 5 (\$ 10) and even the ATmega644 variant that's blessed with twice as much memory sells for under £ 10 (\$ 20). This economic and technical minimalism has a clear con-

sequence: Linux is by no means the only fruit.

Open Source?

Little else remains on our agenda other than to compress the vitally necessary elements of the Internet protocol so that they fit within the Flash memory 'brain power' of an AVR controller. The authors were not the only ones facing this challenge and a number of other programmers had already done some valuable preparatory work along these lines. The good thing about Open Source is that you don't have to

reinvent the wheel from scratch. Consequently it didn't take a huge amount of time to develop a web server on the basis of an AVR controller, especially as not only complete source code but also oven-ready compiled Make files were waiting on the project pages [3] and [4], which even not desperately software-minded folk could flash their controllers without any risk of making errors. There's even a special forum [5] for anyone needing a bit of help. The capabilities of this little server can be found in the box-out along with the technical data. It's quite amazing how much punch this little pack-

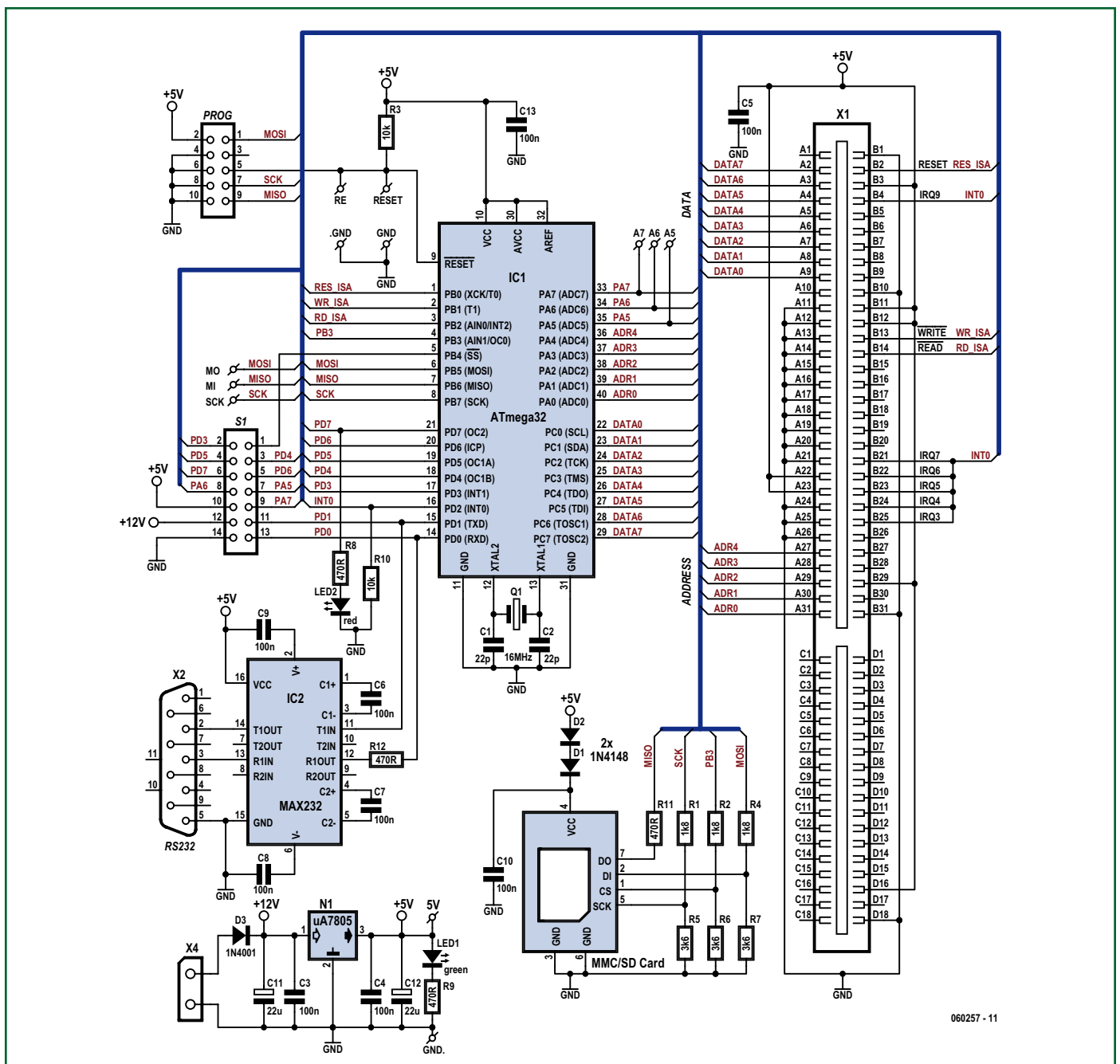

Figure 2. The circuit of the web server is unbelievably simple, as network connection is outsourced to an Ethernet card.

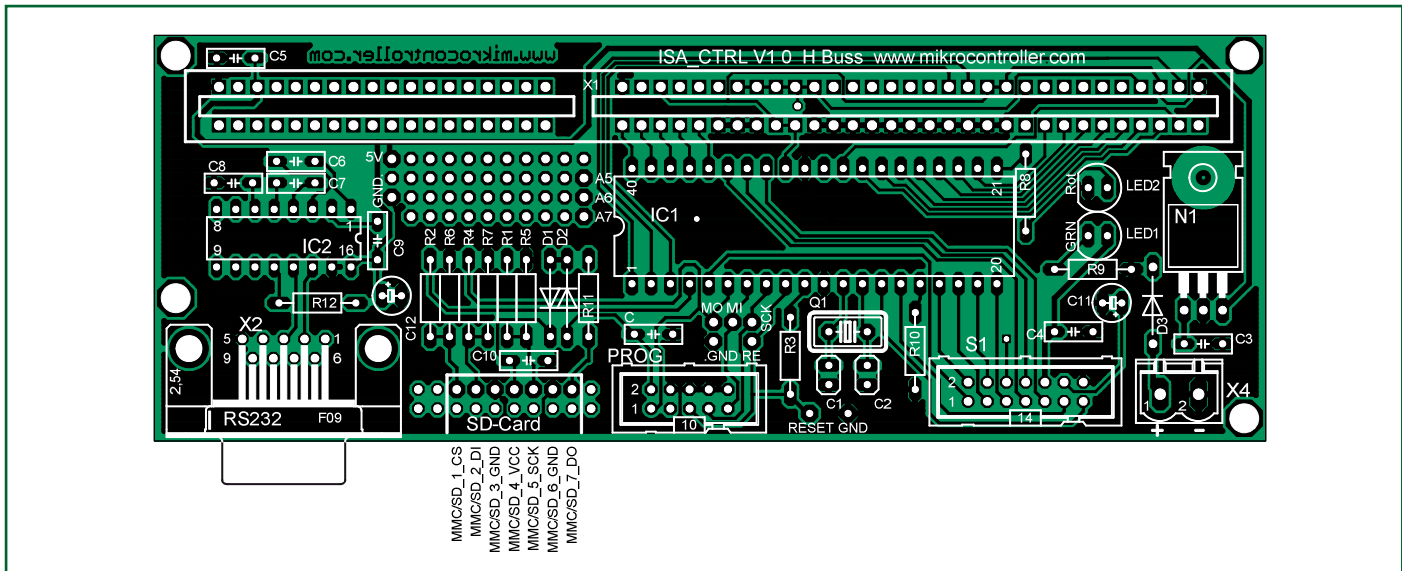

Figure 3. The double-sided PCB of the web server.

age of electronics can pack. On the I/O front adding a low-cost SD memory card is particularly interesting proposition. This makes it easy to alter the web page that the server provides or to optimise the configuration parameters. And a system that's so minimalist is completely secure against hacking attempts.

Nevertheless where there's light you also find shadows. This little server is not intended as a substitute for 'real', full-size servers. The data rates achievable are not earth-shattering (downloads around 10 kB/s) and HTTP and other niceties such as scripts etc. are simply not supported. Device control is the primary function of a small web server like this — for instance, remote temperature sensing and taking pictures with a webcam. Its energy needs, at just under an amp, are not exactly minimalist ecologically but neither are they excessive.

ATmega and firmware

In the circuit shown in **Figure 2** the

microcontroller takes centre stage. As well as this IC there's a MAX232 level converter for the serial interface and a 5-volt voltage regulator. If serial communication is not required you will not need the 12 V supply either, meaning that the web server can be run on 5 V alone. IC2, N1 and D3 need not be provided in this case; D3 can be bypassed and wire links inserted between pins 1 and 3 of the voltage regulator connections. The result then — apart from the Ethernet card — is a single IC web server that's as minimalist as you can imagine. Energy consumption would then fall below 500 mW.

On the authors' web pages you will see a number of firmware versions for which the Flash memory of an ATmega32 will suffice. If you are using what is currently the latest version (v. 1.4) then some extra space will be necessary, meaning the ATmega644 type is required. Shrewd colleagues who enjoy a challenge have managed to slim down the source code by leaving out all the extravagances to make it fit inside an ATmega8! Electrically

it's no big deal whether you use an ATmega16, ATmega32 or ATmega644 in DIL-40 form factor, as they are all pin-compatible.

The version 1.4 firmware offered was compiled for a 'oddball' crystal frequency of 14.7456 MHz, as this makes it easy to derive suitable Baud rates for the serial interface. Using the ATmega644 you are actually giving away or wasting a few MHz, as this chip will happily manage 20 MHz without any problems. If you feel inclined to tickle the hardware to produce more power using a higher frequency you will need to adapt the source code or go without serial communication.

The SD card is actually looking for an operating voltage of 3.3 V. With the help of the two diodes D1 and D2 we get an operating voltage of around 3.5 V and since SD cards are not fussy about supply voltage this is close enough.

As well as the serial interface there are also two SPI interfaces for in-circuit programming using suitable programs (e.g. the **USBprog** in the October 2007 issue *Elektor*) that make use of either 6

components list

Resistors

- R1,R2,R4 = 1kΩ8
- R3, R10 = 10kΩ
- R5,R6,R7 = 3kΩ6
- R8, R9, R11, R12 = 470Ω

Capacitors

- C1,C2 = 22pF, ceramic
- C3-C10, C13 = 100nF foil dielectric, 5mm pitch
- C11,C12 = 22μF 16V, tantalum

Semiconductors

- IC1* = ATmega32 or ATmega644, DIL 40 ATmega644, programmed, order code **060257-41** from Elektor SHOP
- IC2 = MAX232
- N1 = 7805
- D1,D2 = 1N4148
- D3 = 1N4001
- LED1 = LED, green
- LED1 = LED, red

Miscellaneous

- Q1* = 14.7456MHz quartz crystal

- S1 = 14-way boxheader
- X1* = 2x31-way Slot (reichelt.de) or ISA Slot
- X2 = 9-way sub-D socket, PCB mount
- Prog = 10-way boxheader with 6-way (2x3) pinheader
- SD* = 14-way DIL pinheader
- 40-way IC socket
- 16-way IC socket
- PCB, ref **060257-1** from Elektor SHOP

* = see text



Figure 4. The fully populated web server, with room between the two ICs for future expansion developments.

or 10 pins of the interface. The supply voltages and I/O lines are taken to the 14-way 'bathtub' connector S1, which is then wired to the peripheral using flat cable. A classic ISA slot is provided to receive the Ethernet card.

Ethernet

As already mentioned, a card from the days when PCs still came in XT and AT versions can find a new lease of life. In this pre-PCI era so-called NE2000 compatible 10-Mbit Ethernet cards were a quasi-standard for the ISA Bus. It's easy to make these cards respond in 8-bit mode, which is ideal for 8-bit microcontrollers. Cards using a controller from the firm Realtek work particularly well. Keep a special look out for cards with the chip RTL8019AS when you're searching through eBay and other second-hand outlets. These ones will work without any further modification. There may be an EPROM fitted that needs to be removed from the card, as this may contain software for Netboot etc. that may interfere with our operations.

As these cards may have become harder to find in the meantime there's a modification [7] that lets you use 3Com cards with a 3C5x9 chip. Naturally this will involve some alterations to the source code.

Incidentally there's no pressing need to hunt for an actual ISA slot connector. The cards also work in a 2x31-way slot, available at low cost from mail order electronics suppliers. The 2x18 pins missing on the PCB (Figure 3) are in any case only connected to Ground

and +5 V. Both lines are practically always looped round on the Ethernet card itself. Even the ready populated PCB in Figure 4 has only the 2x31-pin slot.

Construction and commissioning

Using no SMD components whatsoever makes putting the components into the PCB a trivial affair. Sockets are recommended for IC1 and IC2, particularly for IC1 if you plan to remove the microcontroller to flash it with a programmer such as the STK500 from Atmel or make any other mods.

The 'socket' we're using for the SD card is a 14-way DIL header connector, which is soldered to the PCB at the position marked. Proper solderable slot connectors for SD cards are not that easy to come by and if you do find them, the cost is out of all proportion. As an alternative there are 2.5 possibilities... and the 'half' option is really a cheat. As shown in Figure 5 the two rows of pins are bent towards one another until their tips are about 1.5 mm apart. Then it's easy enough to solder an SD card between them.

Figure 6 shows how this arrangement works out and is perfectly adequate for experimenting.

A perfectly valid option is to use a Mini or Micro SD card with an adapter to the standard form factor, simply soldering the adapter direct to the seven inner pins (the seven pins on the PCB side have no electrical function).

More elegant but still very affordable is the slot to be found in any low-cost SD card reader (as in Figure 7). The SD



Figure 5. In order to fit an SD memory card between the pins of the DIL header connector the pins of each row are bent inwards until they stand about 1.5 mm apart.

card socket is unsoldered and resoldered direct to the pins of the PCB as seen in Figure 8. Tack-soldering the outer row of pins to the thin metallic shield (Figure 9) provides additional mechanical stability.

The files awaiting you on the project



Figure 6. An SD card fitted between the pins of the DIL header connector.



Figure 7. After cannibalisation a low-cost card reader yields an SD card slot.

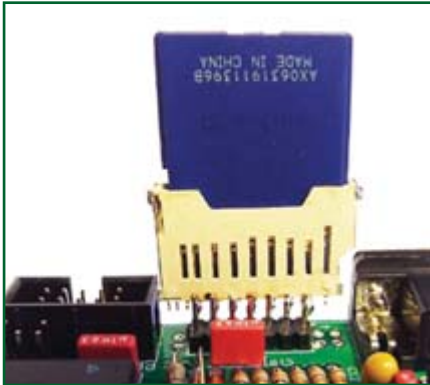

Figure 8. How to solder the pins of the SD card slot to the pins of the header connector.



Figure 9. Improved mechanical stability is the result of soldering the electrically 'dead' pins of the header connector to the metal shielding of the SD card slot.

```

----- AVR-Server V1.4B -----
MMC/SD: Ok. reading 'server.cfg'...Ok
NIC : Init RTL0019: Ok
MAC : 01 00 12 24 00 FF
IP : 192.168.1.102

ROUT: 192.168.1.0
NTP : 132.187.3.3
FTP : 192.168.1.81
SMTP: 192.168.1.81
-----
NTP Enabled=NO
-----
Mail-Trigger Enabled=NO
SMTP AUTH LOGIN=NO
CRM Enabled=NO
CRM Store SD-Card Enabled=NO
FTP Push Enabled=NO
CRM Store (SD or FTP) Time= 5
External Trigger Enabled=NO
    
```

Figure 10: If you see this result in Hyperterminal all your efforts are spot-on.

About the authors

Ulrich Radig and Holger Buss are passionate developers of Open Source hardware and software. Their project pages are devoted to developing the AVR web servers to a higher level as well as a host of other projects.

pages need to be loaded into the SD card. Particularly important is the file named **server.cfg**. In this you will need to enter the IP address using a text editor so that the first three bytes agree with the address of the router. The web page itself is contained in the file **index.asp**. As this is not a high-power server, the older kind of SD card holding a few tens of MB is perfectly adequate.

As an initial test you should observe the output of the serial interface using Hyperterminal. The parameters are: 9,600 Baud, 8 data bits, no parity, 1 stop bit and no flow control. With a supply voltage of 9 to 12 V applied and everything in order, an output like in the screen-shot of **Figure 10** should result. Moreover you should be able to see the web page of the SD card at the selected IP address.

And finally...

The server will also work without the SD card. In this case you need to connect an additional 100 kΩ pull-up resistor from pin 7 of the SD card interface to +5 V, ensuring that the server is in no doubt that a SD card is not present. The resistor does not interfere with operation when an SD card is fitted. In version 1.4 firmware the IP address 192.168.1.201 is prescribed when an SD card is not used. Although the server is certainly not the zippiest, a Ping is normally answered within 1 ms by the way.

At [5] you can access the test setup at the Elektor lab (**Figure 11**) in real time. But not everybody at once please as we designed it for less than 1,000 simultaneous accesses per second ;-)

If you wish to hook up peripherals such as temperature sensors or a webcam please take a look at the authors' project pages on the Web, where you will find detailed information.

(060257-1)

Web Links

- [1] www.ulrichradig.de
- [2] www.mikrocontroller.com
- [3] www.mikrocontroller.com/eng/avr_webserver.php
- [4] www.elektor.com/webserver
- [5] www.elektor.com/testserver/
- [6] www.ulrichradig.de/site/forum/viewforum.php?f=5
- [7] www.mikrocontroller.com/de/ISA_3Com.php
- [8] www.atmel.com/dyn/resources/prod_documents/doc2593.pdf



Figure 11. This is the message display from our prototype web server in the Elektor lab.

10% OFF Enter Discount Code At Checkout
Online Orders XMAS07
www.pcb-soldering.co.uk Valid until 15/01/08

<p>850A+ SMD Rework Station</p>  <p>Discounted Price £40.46</p>	<p>932 Vacuum Pick Up Station</p>  <p>Discounted Price £26.96</p>	<p>937+ 45W Soldering Station</p>  <p>Discounted Price £34.16</p>	<p>Range Of Tools & Accessories</p> 
<p>2738 CPU Controlled PCB Work Station</p> <p>Kit Includes: Hot Air Gun 6 x Air Nozzles 70W Soldering Iron with Fume Absorber Soldering Iron Stand Soldering Iron Tip with Heating Element Vacuum Suction Pen Heat Resistant Pad IC Removal Tool 2 x Carbon Filters</p>  <p>Discounted Price £125.96</p>	<p>2900 70W Soldering Station</p>  <p>Discounted Price £67.46</p>	<p>710 Infrared Welding Station</p>  <p>Discounted Price £675.00</p>	<p>Soldering Iron Tips & Air Nozzles</p>  <p>Wide Selection Available</p>
<p>853A Quartz Infrared Preheater</p>  <p>Discounted Price £62.96</p>	<p>950 SMD Hot Tweezers & Station</p>  <p>Discounted Price £40.46</p>	<p>TEST-PINS.CO.UK Suppliers of Test-pins, Receptacles & Probes... For Test-pins & Probes Visit www.test-pins.co.uk Above discount code also applies</p>	

www.pcb-soldering.co.uk

Allendale Electronics Ltd, 43 Hoddesdon Industrial Centre, Pindar Road, Hoddesdon, Hertfordshire. EN11 0FF.

T: +44 (0)1992 450780 W: www.pcb-soldering.co.uk
 F: +44 (0)1992 450781 E: sales@pcb-soldering.co.uk

ANTEX

Antex offer a wide choice of input voltages and bit profiles for our soldering iron range



visit: www.antex.co.uk

60+ years of experience

www.antex.co.uk
 FREE shipping on all orders

It may surprise you but buying an Antex soldering iron costs less than you think in the long run. British made to exacting standards, they last significantly longer than many imported brands. With a wide range of thermally balanced models, and temperature controlled irons too, you can always be sure to find an iron that meets your needs.

A large range of replacement tips are available for most irons, and technical help is on hand from our offices in Devon UK.

Buy Online

Our new website has all of our irons, and soldering spares and accessories available 24hrs a day. Most items are shipped next day, and we offer free carriage throughout Europe. Why not give antex.co.uk a try!

Antex Electronics Ltd
 2 Westbridge Industrial Estate
 Tavistock, Devon PL19 8DE, UK
 Tel: +44(0)1822 613565
 Fax: +44(0)1822 617598
 Email: sales@antex.co.uk
 Web: www.antex.co.uk

Voice recognition, speech, music synthesis

VR Stamp™ Toolkit



Antoine Authier & Guy Raedersdorf

Sensory® has been well-known for over five years for its modules that make it possible to add voice recognition to an electronic product.

As so often the case in electronics, things are evolving very fast. We were lucky enough to have the latest baby from the Sensory stable, the VR Stamp™ Toolkit, arrive on our desk. Let's take a little look at what it has to offer.

Let's start right away by clearing up a puzzle – what do the two letters VR mean in the prefix of the various Sensory® products? Well, they're quite simply the acronym for **V**oice **R**ecognition.

What's it for?

The VR Stamp™ from Sensory fulfils a triple rôle: to give any kind of product a voice recognition capability, to make it possible for it to 'speak', and lastly, to give it the capacity to synthesize music. The VR Stamp is the first speech module (combining voice recognition and speech generation) to use the Quick T2SI (**T**ext **T**o **S**peaker **I**ndependent) technology from Sensory – not at all surprising, since it is the intellectual property of this company. It takes no more than a few

minutes to be able to create a voice module. Another attraction of this approach is its support for different languages (up till now, we've generally been limited to just English), making it possible to envisage creating products practically anywhere in the world. The box is a real treasure-chest: a mother board with ZIF socket for the VR Stamp Module and a serial EEPROM allowing data to be re-written, a power supply, a pair of CD-ROMs, a USB cable, and even a USB dongle (!) used to protect the compiler.

Piggy-back board

In the first photo (**Figure 1**) we see the VR Stamp™ Toolkit, which serves as a support for the VR Stamp™ proper, i.e. the VR Stamp™ Module.

Technical specifications

FluentChip Technology

- Recognition, both SI (Speaker Independent) and SD (Speaker Dependent)
- Several language modules for international applications
- High-quality 2.4 compression at 10.8 kbps
- Sound effects supported by Sensory's 'SX' synthesis technology
- SVWS (Speaker Verification), biometric security by vocal password
- 8-voice MIDI-compatible music synthesis
- DTMF tone synthesis

- Standby mode for audio amplifier

VR Stamp™ Module

- RSC-4128 speech processor
- 1 Mbit Flash memory
- 128 kbit data EEPROM
- Dual clock (system 14.3 MHz and crystal-controlled 32 kHz time-keeper)
- 24 Input/Output lines
- Mic preamp
- PWM for speaker
- Optional DAC output
- Low power consumption: 26 mA @ 3 V, <20 µA in standby

The Toolkit comprises everything you need to program the VR Stamp™ as you wish. In reality, the Toolkit is a programming tool used to transfer an application program into the VR Stamp module via a PC USB port. The board uses a ZIF (Zero Insertion Force) socket that lets you insert and remove the Module without risk.

The VR Stamp™ is a small circuit board in standard 40-pin DIL format (pin 1 of the module must be at the insertion lever end of the socket). After programming, it can be plugged directly into the application. The Toolkit comes with a pair of CD-ROMs: the Toolkit CD and the Phyton CD-ROM with a 3-month limited version of this company's C compiler.

At the heart of the module

The heart of the VR Stamp is an RSC-4128 processor from Sensory's own foundries. If you want to know more about it, we can do no better than recommend you to take a look at its datasheet [1]. The interesting aspect of this series of dedicated processors in the RSC-4x family is that they support the FluentChip™ technology, which employs extremely high-performance algorithms that allow greater possibilities and also more accurate processing (recognition and speech). Besides its voice recognition functions, the RSC-4x family is characterized by the presence of a certain number of on-board functions, including for example a microphone preamplifier, a pair of DMA (Direct Memory Access) units, a vector accelerator, a hardware multiplication unit, three timers, and not forgetting almost 5 kB of RAM used for temporary storage of data being processed. Given all the functions crammed into the processor, only a few additional components are needed to produce an operational project: a speaker, a microphone, power (battery), and a handful of resistors and capacitors.

Figure 3 show the block diagram of it. Don't be deceived by this, as it's extremely simplified. Besides the lines shown here for power, mic and speaker connections, and an RS-232 interface (SERIAL PORT), there are also no less than 24 I/O lines available.

Let's get down to business!

After this brief introduction, it's high time to get an idea of how this tool is used in practice. Contrary to the usual practice of many of us, let's start by reading the documentation on the CD-ROM.

After that, the first step consists of installing the support programs. First of all, you need to locate on the CD-ROM



Figure 1. The VR Stamp™ Toolkit is in fact a mother board, onto which the VR Stamp™ Module is piggy-backed.

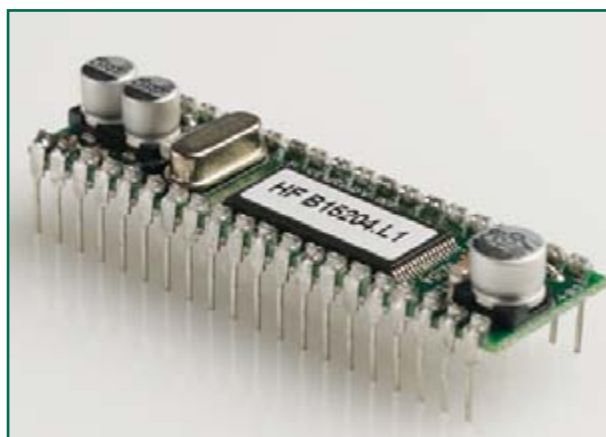

Figure 2. The VR Stamp™ Module in all its splendour.

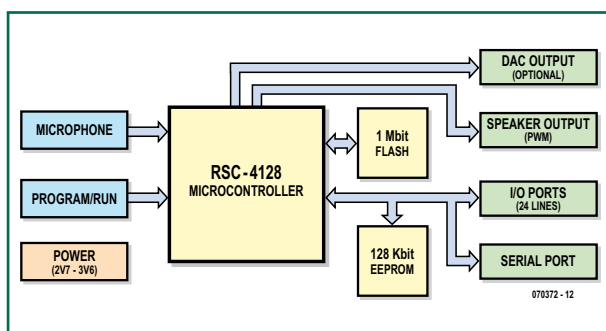

Figure 3. If you have an eye for technology, you'll doubtless be impressed by the apparent simplicity of such a high-performance component.

The competition

In the past, we have seen various circuits: one capable of synthesizing words to generate phrases with a very artificial timbre (Texas Instruments – you had to visit their laboratories to record, with great difficulty, the texts to be stored in ROM, and there was no question of changing anything later); the other able to convert words into synthesized sound (the SP0256 from General Instruments, which knew only 59 English phonemes – mostly numbers and figures – and 5 pauses of various lengths; just try saying anything meaningful with these rudiments of language!). And a third, like the TTS256, which is

not, contrary to what one might think, from Texas Instruments, but from Magnevation.

Another component from this same company does deserve a mention: its SpeakJet [3], programmed with 72 speech elements (allophones), 43 sound effects, and – yes, you have to read it to believe it – 12 sounds corresponding to the DTMF dial tones.

Choosing judiciously from these various elements and combining them with different variable parameters such as volume, pitch, roundness, and frequency makes it possible to produce all the phrases and sound effects in the world. But it's nevertheless a really painstaking task.

Once the drivers are correctly installed and the dongle recognized, Phython ought to install without problem. Phython Project-SE offers a simulator and an on-chip emulator, in addition to the development, assembler, and compiler environment.

The screen dumps illustrate different stages in using this universal tool.

Tools

The Toolkit provides samples and demonstration modules illustrating the technologies Sensory employs to simplify to a maximum the development of everything related to voice recognition and speech generation. QuickSynthesis™ 4 allow recordings of speech to be compressed quickly with the right combination of size and quality.

On the Toolkit CD-ROM are the FluentChip™ technology library, and the QuickSynthesis™ 4 and Quick T2SI-Lite™ tools supporting language packs, allowing creation of vocabularies on a world-wide level. The latter module's Lite suffix is certainly justified, as it is limited to 50 vocabulary creations or 6 months' use, whichever is reached first.

On the second 'Phython' CD-ROM we find an IDE (Integrated Development Environment) comprising an assembler, a linker, and a C compiler (restricted as mentioned above).



All the technologies offered by the FluentChip™ library are available for use on the VR Stamp, with the exception of Record & Play (due memory constraints).

A fascinating world

If you're interested in the subject of speech synthesis in all its various aspects, we can do no better than recommend you to pay a visit to the website referred to in [2] of the links. You'll see that there are many roads leading to Rome, but none of them has the universal capabilities of the VR Stamp™ Module.

(070372-1)

Bibliography and links

- [1] <http://backoffice.inware.it/files/prodotti/download/sensory/rsc4128data.pdf>
- [2] www.speechchips.com/shop/
- [3] www.sensoryinc.com/
- [4] Distributor : www.tigal.com

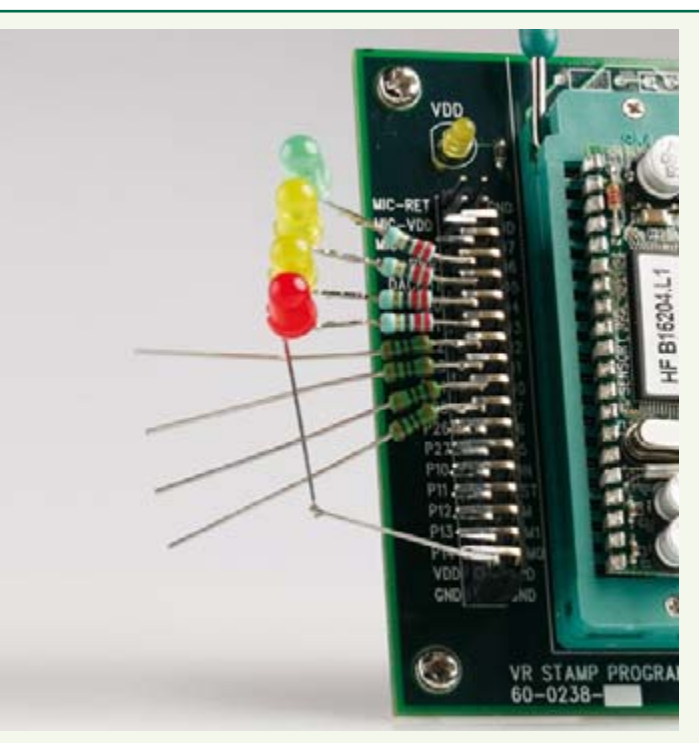

Craft Drill Controller

for semi-automated PCB drilling – and more

David Clark

For example, the final speed for the drill can be preset, as can the time the drill takes to speed up to, and slow down from, this final speed. The drill can be run in this 'timed' mode, or can be run continuously as normal. Furthermore, the drill can be switched on and off via a footswitch, leaving both hands free for positioning the drill and the PCB. The Craft Drill Controller is also useful for the control of other 'mini' cutting and polishing tools that can be fitted to small 12-V powered drills of the 'Dremel' and 'Proxxon' variety, which come in a wide range of product qualities, of course matched by the price tag.

Accuracy vs. Tedium

The recommended way of drilling a PCB is to use a mini drill running while fixed in a small drill stand. However, this method is slow and inflexible. The alternative, hand-holding the drill, can easily result in imprecise positioning and/or the drill 'skidding' across the PCB, an equally frustrating situation. The Craft Drill Controller overcomes these difficulties in the following ways:

1. The controller automatically switches the drill on and off, allowing the

user to carefully position the drill while it is off and then hold it in position until the drill starts.

2. Drill-on and drill-off times can be individually set.
3. The same for the speed-up and slow-down rates for the drill as it 'ramps' between off and its final speed and vice versa.
4. The final speed, too, can be set by controller.
5. Footswitch control is optional, keeping both hands free to position the board and lower the drill.

All settings can be 'fine-tuned' in such a way that the user quickly establishes a 'rhythm', according to his/her own natural pace in using the drill, which speeds up the drilling process and relieves much of the tedium of this job.

Principle Of Operation

The Craft Drill Controller does not provide the power to the drill, but instead is connected **between** the drill and its conventional DC power supply (set to maximum), and it controls how the supply power is applied to the drill.

A block diagram for the Craft Drill Controller is shown in **Figure 1**. Control of the drill speed is achieved by a form of

Designing and making a printed circuit board (PCB) for a project has many advantages over using stripboard, but there is one big disadvantage – drilling the holes. Our Craft Drill Controller takes away some of the tedium of this task by semi-automating the way a 12V mini drill has its speed controlled, so saving time and drill bits!

pulsewidth control, in which three levels of pulsewidth control are combined to control overall on/off timing, ramp up/ramp down rate, and final speed.

The circuit

Let's have a look at the circuit diagram shown in **Figure 2**. Apart from a five-volt regulator, the circuit is built entirely around general-purpose transistors, bipolar ones (BC550C; BC560C, TIP122) as well as FETs (BS170; BS250P). The pulses are generated by three astable multivibrator circuits; the timing of these is, however, controlled by variable constant-current capacitor charging rather than the usual capacitor-resistor timing. This gives better timing and more linear control settings.

The first astable multivibrator is based around transistors T14 and T16. T8 and T10 are the constant-current sources, the currents being set by eternally connected potentiometers P3 and P4. These control the 'on' and 'off' times of the astable, which correspond to the on and off times for the drill. In the circuit diagram, 'ccw' means counter-clockwise, this indicates one of the outer legs of the pot the wire has to be connected to. The centre leg (c) of a potentiometer is invariably the 'wiper' and goes to the centre pin of the relevant connector.

The outputs from the first astable are applied, via FET buffers T12 and T13, to the two sets of 'ganged' (a.k.a. stereo or 'tandem') potentiometers that control the charging currents for the second astable, which is based around T5 and T6. This second astable controls the 'speed-up' rate applied to the drill when the output of the T14/T16 astable switches the drill on, and the 'slow-down' rate when the astable causes the drill to be turned off.

The output of the T5/T6 astable passes, again via a buffer, T1, to what is in effect an AND gate, consisting of diode-resistor logic components D1, D8 and R1. Thus the output of this astable ANDed with the output of the next astable, which is based around T15/T17. This one sets the final, i.e. maxi-

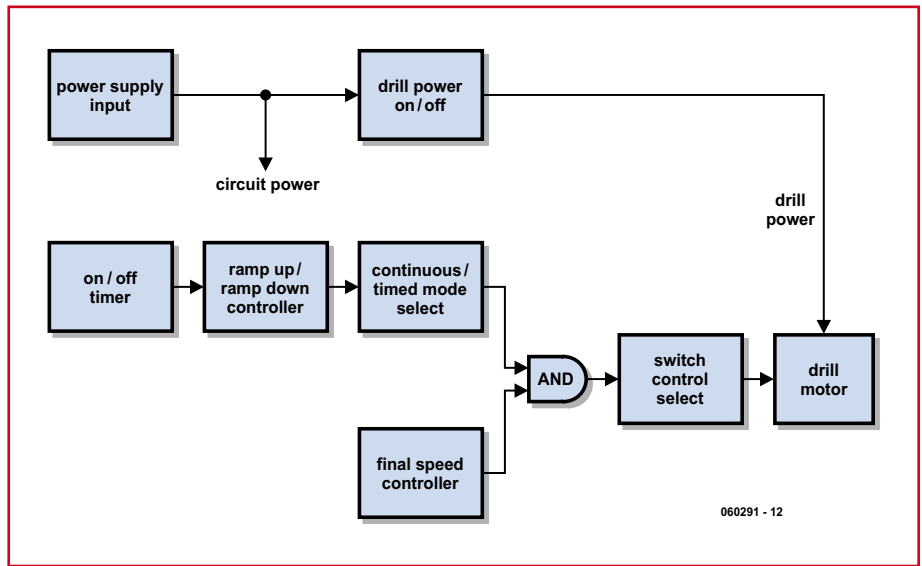

Figure 1. Block diagram of the Craft Drill Controller. Electrically, the circuit sits between the 12-15 V PSU and the hobby drill.

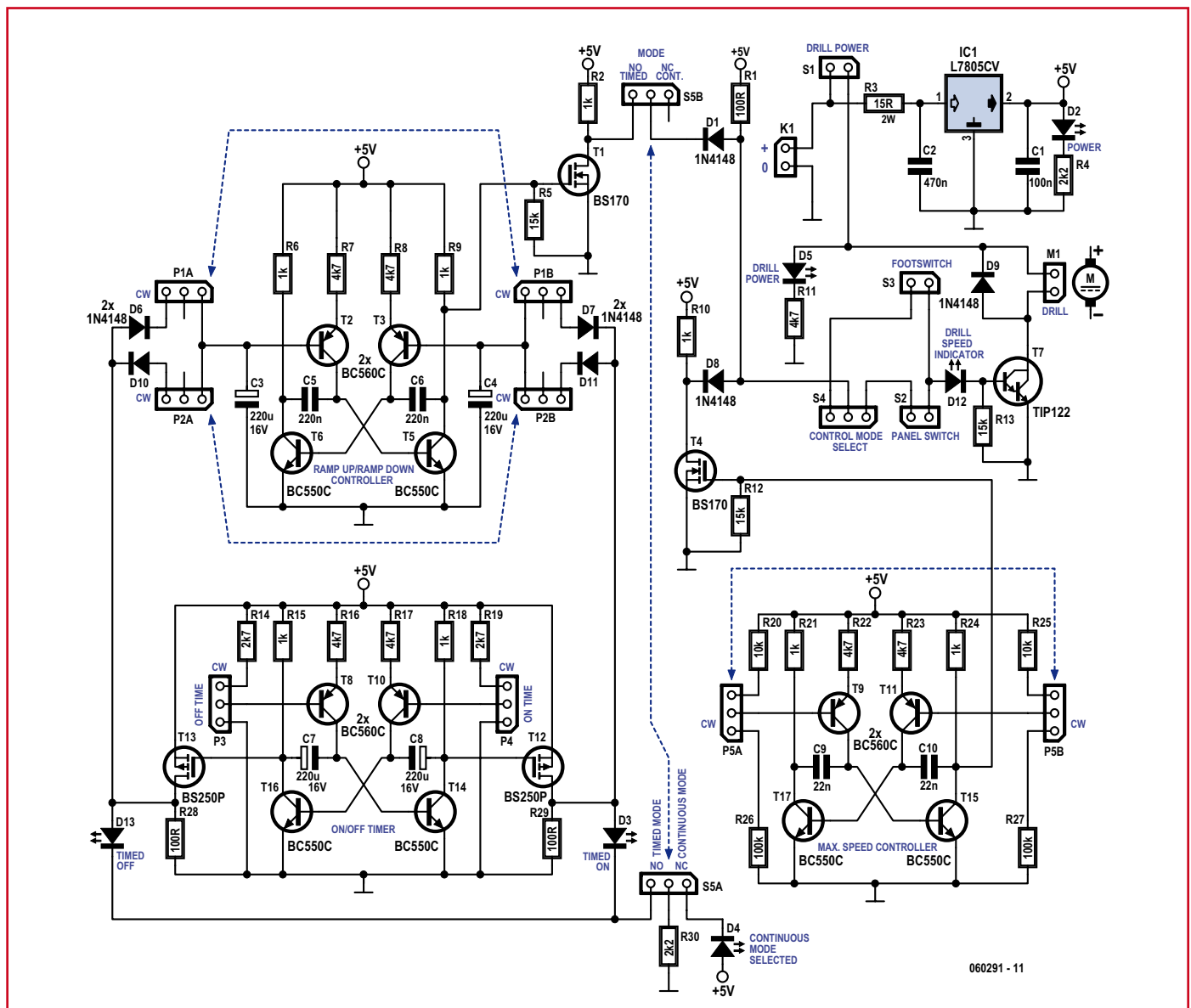

Figure 2. All three astable multivibrators in this circuit are built from discrete parts. An improved control characteristic for the various ramp voltages generated by the circuit is achieved by using constant-current sources rather than R/C networks.

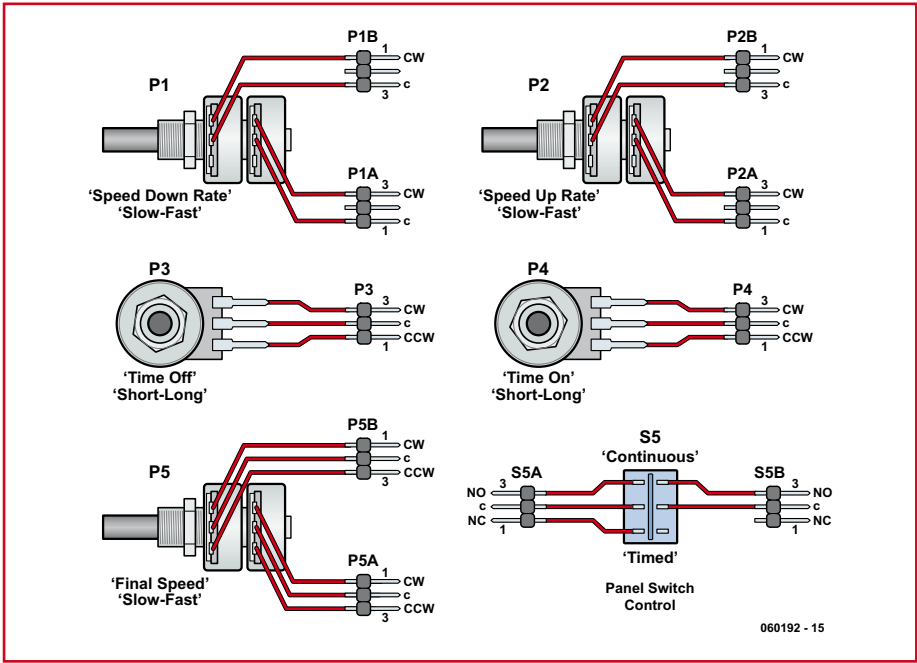

Figure 3. Pictorial representation of connections of some of the external controls to the circuit board.

...mum, speed of the drill by controlling the mark-space (on/off) ratio of the pulses applied to the drill motor via a power Darlington transistor, T7. The 'mode' of the drill controller, i.e. continuous or timed mode, and foot or panel control, is determined by switches S3, S4, S5 and S6, which simply 'route' the motor control pulses. Various light emitting diodes (LEDs) indicate the state of operation at any moment.

Two more switches on the rear panel of the Craft Drill Controller control power to the controller circuitry as supplied by the external power supply, which must of course match the power requirements for the drill. A main power switch should be provided on the back panel, controlling the supply to both the drill and the controlling circuit. S1 allows the power to the **drill only** to be switched off, for when it is required to

COMPONENTS LIST

Resistors

- R1,R28,R29 = 100Ω
- R2,R6,R9,R10,R15,R18,R21,R24 = 1kΩ
- R3 = 15Ω 2W
- R4,R30 = 2kΩ
- R5,R12,R13 = 15kΩ
- R7,R8,R11,R16,R17,R22,R23 = 4kΩ
- R14,R19 = 2kΩ
- R20, R25 = 10kΩ
- R26,R27 = 100kΩ
- P1,P2 = 5kΩ linear-law potentiometer
- P3,P4 = 10kΩ linear-law potentiometer
- P5 = 50kΩ linear-law stereo potentiometer

Capacitors

- C1 = 100nF
- C2 = 470nF
- C3,C4,C7,C8 = 220μF 25V radial electrolytic
- C5,C6 = 220nF
- C9,C10 = 22nF

Semiconductors

- D1,D6,D7,D8,D9,D10,D11 = 1N4148
- D2,D3,D4,D5,D12,D13 = LED, low current
- T1,T4 = BS170
- T2,T3,T8,T9,T10,T11 = BC560C
- T5,T6,T14,T15,T16,T17 = BC550C
- T7 = TIP122

T12,T13 = BS250P (watch suffix P)
IC1 = L7805CV

Miscellaneous

- S1 = on/off switch, 1 make contact
 - S2 = on/off switch, 1 make contact
 - S3 = footswitch, on/off, 1 make contact, see text.
 - S4 = single-pole changeover switch
 - S5 = single-pole changeover switch
- PCB, ref. 060291-1 from ThePCBShop; free artwork download # 060291-1.zip from www.elektor.com
Front & rear panel artwork files, free download from www.elektor.com

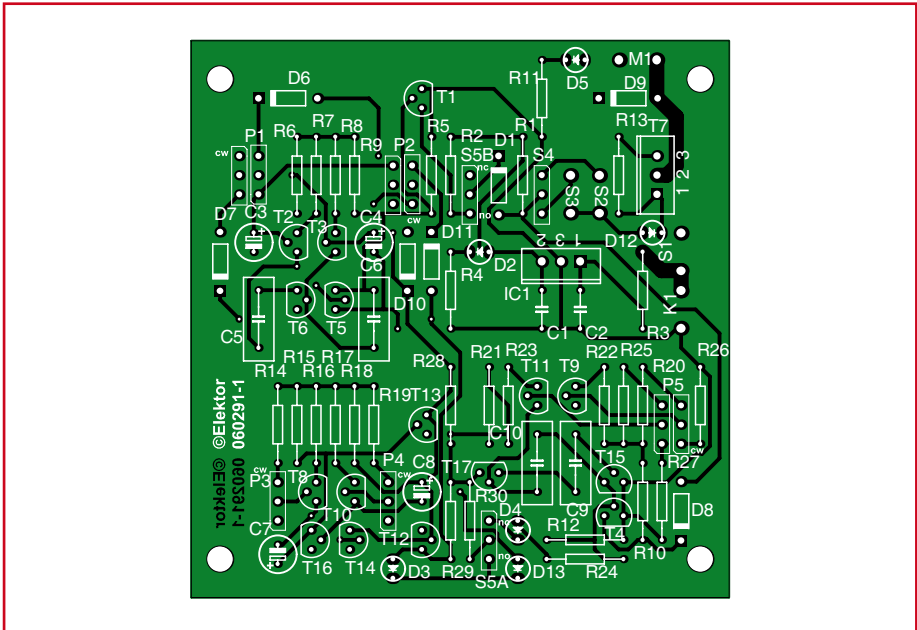

Figure 4. Component arrangement on the printed circuit board designed for the Craft Drill Controller. Copper track layouts available free from our website.

have the controller running but to ensure that the drill is not allowed to run accidentally.

To prevent supply voltage fluctuations affecting the timing circuits, these are powered via a 5-volt regulator, IC1. To reduce inefficiency and over-heating in IC1, resistor R3 drops the voltage applied to the regulator input.

A 2-amp fuse should be connected between the PSU and the supply input of the controller to protect the overall circuit.

The controller was designed to operate with a supply of between 12 and 15 volts DC. Nevertheless, it should be possible to use drills of higher voltage and power if component specifications are updated, in particular those of the fuse, R3 and T7. Heat sink requirements for IC1 and T7 should also be consid-

ered – in the prototype they were fixed to the inside of the aluminium rear panel using insulating washers.

Construction

Construction is straightforward thanks to the use of none but standard leaded components that might well be lurking

Populating the board is a breeze as there are no SMDs or multi-legged microcontrollers to fit.

ing in your junkbox, with no special measures or setting up required, other than the usual care over handling electrostatic-discharge (ESD) sensitive components.

The component mounting plan of the double-sided printed circuit board we've designed is given in **Figure 4**. The .pdf file with the copper track layouts (reflected and non-reflected) for home production of the circuit board is available as free download from the *Elektor* website. Populating the board is a breeze as there are no SMDs or multi-legged microcontrollers to fit. The connections to the external components (switches and pots) are illustrated in **Figure 3**. Work with care and take your time to do this wiring job. The blue, dashed, lines in the circuit diagram indicate that potentiometers P1 and P2 are ganged versions operating in tandem.

Your completed, wired up board should look something like our lab prototype

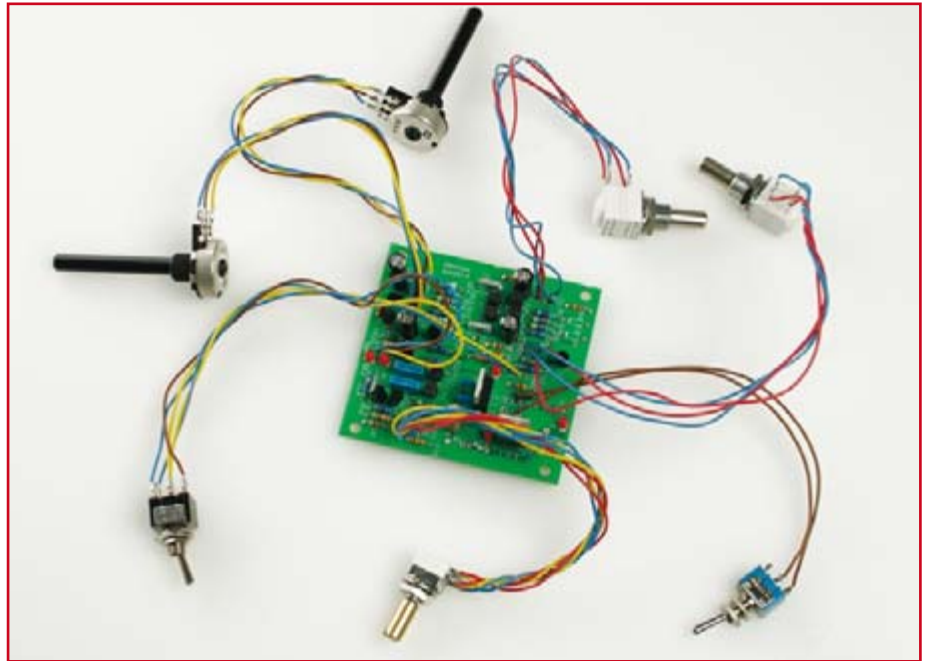

Figure 5. Our fully working, populated and wired up board.

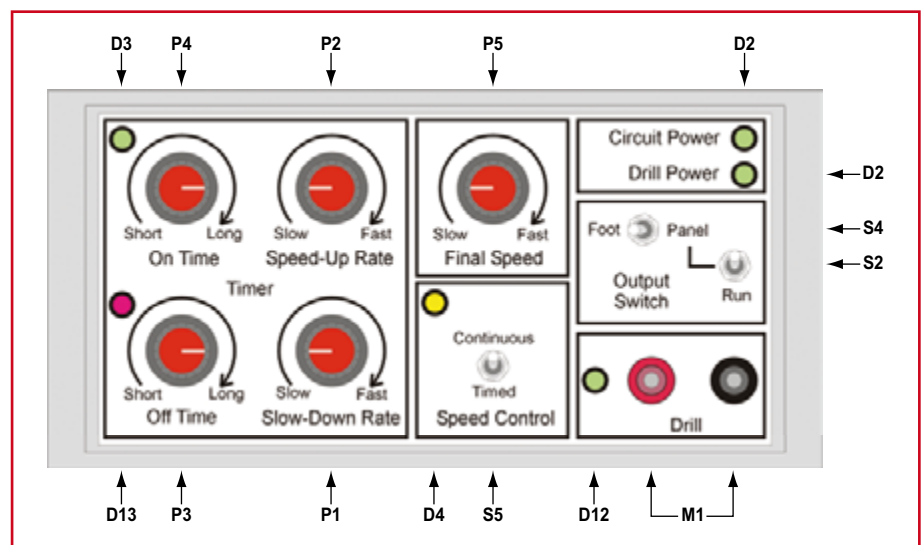

Figure 6. Suggested layout for the front panel (file for full-size artwork available as a free download).

It should be possible to use drills of higher voltage and power if component specifications are updated.

pictured in **Figure 5**. Do not fit your board into a case before it has been tested 'live', i.e. with a power supply and a drill connected, and you are satisfied with the operation. If you find that a pot regulates the wrong way around, simply swap the wires to the outer legs.

Figures 6 and 7 show suggested layouts for front and rear panels, respectively, for a housing for the controller.

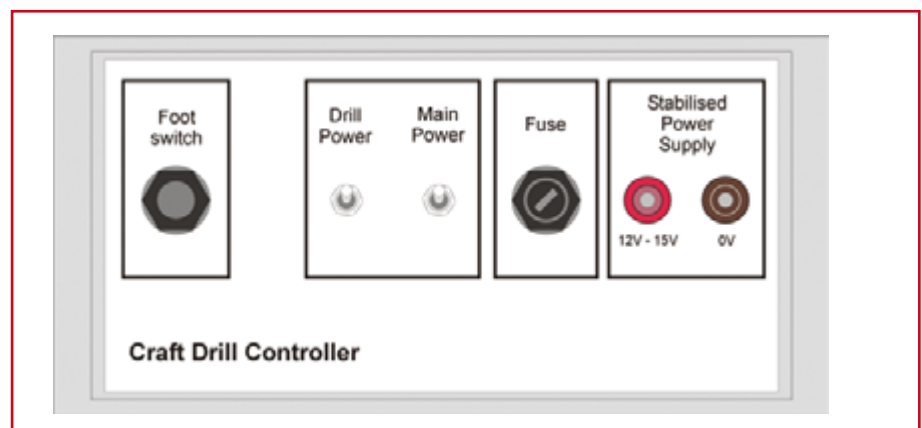

Figure 7. There's a few things on the rear panel, too, and this is how you could arrange and label them (file for full-size artwork available as a free download).

The artwork for these panels is also available as a free download for editing and/or scaling (if you want) using your favourite graphics design program. As the diagrams indicate, 4-mm plug (banana) sockets were used for connections to the drill and the power supply, and a 0.25-inch (6.3 mm) jack socket was used for the footswitch connector. The footswitch itself can be a latching or non-latching type as preferred.

In Use – your preferences rule

Make sure the main power on/off and drill power switches are off, and then



Safety First

The usual precautions regarding eye protection etc. apply of course, particularly when using a hand-held drill with a small tungsten carbide drill bit, as these can be brittle and prone to breaking under sideways stress.



connect the power supply and the drill to the controller, and a footswitch if one is required. Switch the main power on/off switch to on, but do not switch the drill power switch on until everything is set up and ready for use.

How the controller is used will of course depend on the job in hand, the choices being for:

footswitch or front panel control – flip the Foot/Panel switch. The drill can then be switched on and off using the footswitch or the 'Run' front panel switch as selected, for either:

Timed or Continuous operation – set the 'Speed Control' switch on the front panel.

If timed operation is selected, adjust the four Timer controls until a comfortable working 'rhythm' is achieved by varying how long the on and off cycles are, and how long it takes to speed up to, or slow down from, the final speed as set by the Final Speed control.

If continuous operation is wanted, switch the drill on and off as required, at the speed set by the Final Speed control, using the footswitch or Run switch as selected above.

The Final Speed setting will be chosen according to the material being drilled or perhaps according to the tool being used if the controller is used with, say, a polishing or grinding tool. Safety precautions are mentioned in the **inset**.

In Conclusion

The Craft Drill Controller is a low-cost circuit of whose functionality and versatility is surprisingly hard to find commercially. It should make perhaps the most time-consuming part of producing a PCB a little more pleasurable, and get rid of the final excuse for choosing stripboard over a purpose-designed PCB, for the electronics constructor without access to a high-end programmable drilling machine!

(060291-1)

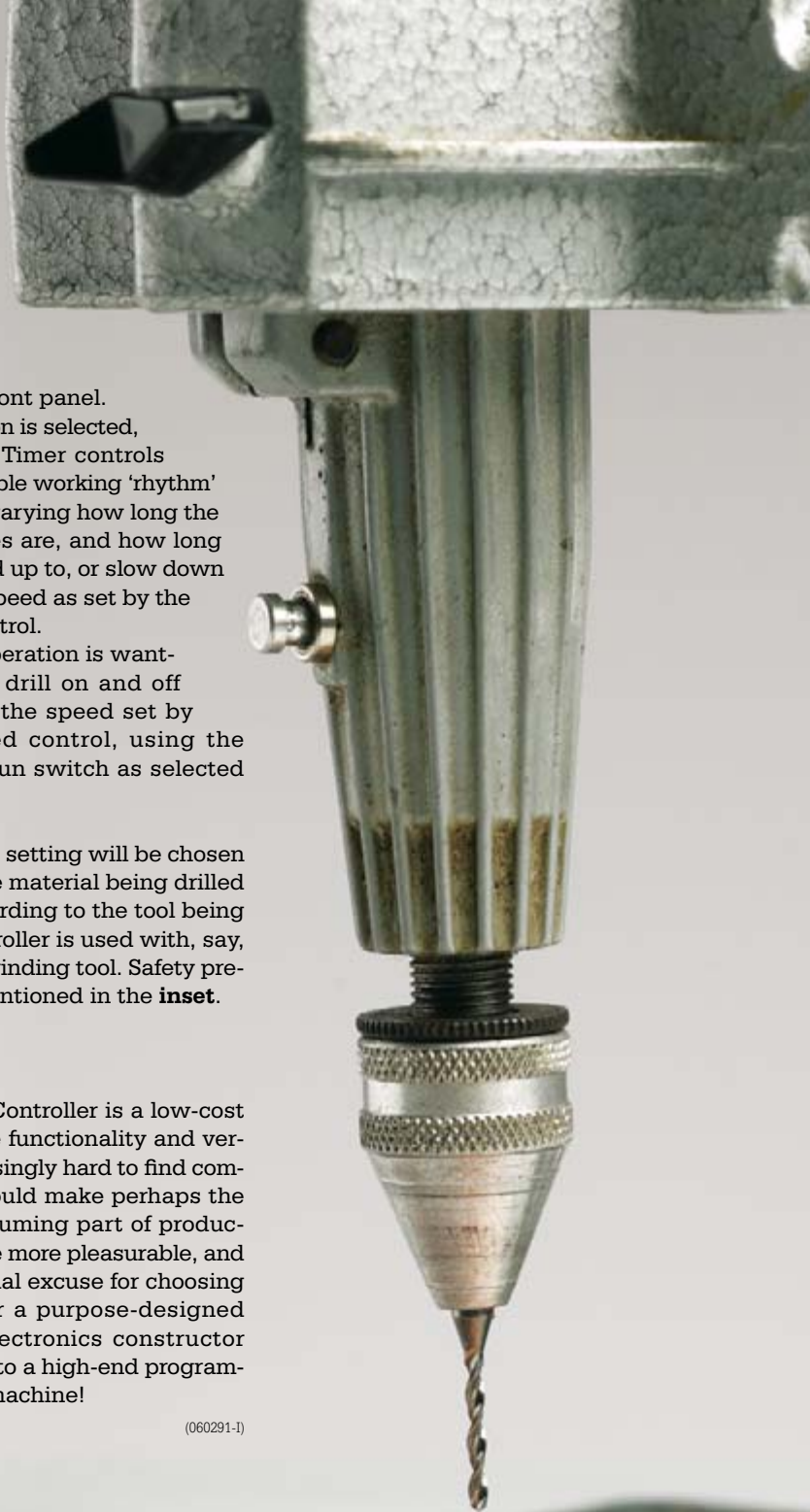



How many pieces of test equipment can you buy for £99?

With a PoScope USB instrument you get the features of an oscilloscope, spectrum analyser, chart recorder, logic analyser (with UART, SPI, I²C and 1-wire serial bus decoding), pattern generator and square-wave/PWM generator. That's equivalent to six pieces of test equipment for £99 including UK delivery and VAT.

PoScope is a low-cost USB-based instrument that adds invaluable test equipment features to your desktop or notebook PC. Being PC-based, all measurements can be printed, copied to the clipboard and saved as text, bitmap or vector graphics for subsequent analysis or to import into other programs. PoScope is ideal for use by electronics hobbyists, students and engineers alike and is particularly suited to those developing with microcontrollers such as PIC and AVR.

PoScope provides the following operation modes:

- 2-channel oscilloscope with 100Hz to 200kHz sampling, -20V to +20V input range, 10-bit ADC resolution, absolute, differential and external triggering, adjustable pre-trigger and marker measurements.
- 2-channel spectrum analyser with klirr factor measurement, Hamming, Hanning, Blackman and Blackman-Harris FFT window functions.
- 2-channel chart recorder with 0.01Hz to 200kHz sampling, maximum, minimum and average voltage measurements for each channel and waveform record over several tens of hours.
- 16-channel (8 when pattern generator used) logic analyser with 1kHz to 8MHz sampling, versatile triggering with adjustable pre-trigger, external clocking, preset pulse miss, preset bit sequence/edge, decoding of UART, SPI, I²C and 1-wire serial interfaces.
- 8-channel 1kHz to 1MHz pattern generator with tabular waveform formatting or direct timing chart plotting on the screen.
- Square-wave/PWM (pulse width modulation) generator.

Compatible with Microsoft Windows ME, 2000 and XP, PoScope is supplied with easy-to-use software and a USB cable. Oscilloscope probes and logic analyser test lead/clip sets are available separately.

Order now on **Freefone 0800 612 2135** or online at www.paltronix.com

PALTRONIX
EQUIPMENT FOR ELECTRONICS DEVELOPMENT, TRAINING & EXPERIMENTATION

Paltronix Limited
Unit 3 Dolphin Lane, 35 High Street, Southampton SO14 2DF
Telephone: 0845 226 9451 Facsimile: 0845 226 9452
Email: sales@paltronix.com Web: www.paltronix.com



All major credit and debit cards accepted

Learn Young... Electronics lab kits



Harry Baggen



Most of our readers can doubtless still remember how they first learned about electronics. What could be nicer for an electronics enthusiast than to help his or her children take their first steps into the world of electronics? Electronics lab kits let children of all ages experiment with electronics to their heart's content.

A good way to get started with electronics is to buy an electronics lab kit. These kits usually have boards that make it easy to interconnect various electronic components, and many of them have components fitted to a front panel. Small springs attached to the terminals of the components can be used to connect them together using various lengths of insulated wire included in the kit. The stripped ends of the wires can be clamped between the turns of the springs. Most kits can be used to build several different circuits, and the number of circuits is often indicated in the name of the kit, such as '130-in-1 Electronics Lab Kit'. The size and price of the kit is generally proportional to the number of circuits that can be built with it. Relatively large kits let you use individual components placed in a breadboard area in addition to the fixed components. This gives you more of a feeling of actually putting together a circuit, and it considerably increases your freedom to modify the circuits on your own. Some kits also have a selection of control elements, such as linear and rotary controls. This makes the controls a lot

more realistic for young users and thus more interesting. After all, most of the components are 'black boxes' for beginners, even of their operation is described in the user's guide. The kits described in this overview can be divided into two groups: Maxitronix kits and Kosmos kits. This seems to cover most of the commercially available kits; we omitted kits specifically made for school use from consideration here, although some are listed in the **table**. Kits from the Chinese company Maxitronix are sold all over the world under various names and descriptions. The smaller kits in this family are remarkably simple. They have a base panel made from cardboard with a thickness of several millimetres, with the components and spiral springs attached to this panel. The edges are plastic, and the bottom covering is also made from cardboard. In some cases it is quite thin and held in place with a bit of adhesive tape. You shouldn't expect much luxury here, but the prices are relatively low — you can buy a kit that will give you hours of pleasant experimenting for just a few dozen quid. The larg-



Practical test

Besides the assessment of the various kits by our editorial staff, we also had several youngsters perform a 'field test' with a couple of kits. The following are some of the characteristic responses.

Guy (age 15)

Tested: Electronic XN1000

- The introduction and explanation in the user's guide make a childish impression. I already feel too old for them.
- Some of the words used in the explanations are much too difficult.
- Assembly is nice and easy.
- The components don't always match the descriptions, and the wire colours are sometimes not the same.
- Most of the experiments work right away, but if something doesn't work, there aren't any instructions on how find the problem.
- It is not always clear what results you should expect from the circuit.
- It's actually an interesting lab kit!



Frits (11) and Luuk (12)

Tested: Electronic Lab 30 in 1

- It's all pretty difficult at first, and you need some explanations from an adult.
- The kit looks interesting, and it's very 'technical' with all those parts and springs. (For comparison, they were given a Kosmos kit to look at, but they found its appearance not at all interesting.)
- Putting together the circuits is easy, and almost all of the experiments work right away.
- It's fun to fit the wires according to the wiring diagram and then see whether the circuit does something, but we don't find the explanations in the user's guide interesting.
- You actually find out something about electricity with this; at school you don't learn anything about it.
- I wouldn't buy it myself; I'd rather spend the money on something else. And once you have done all the experiments, you won't use the kit any more (however, they would like to have a kit like this as a gift).



er kits from Maxitronix (such as the '300-in-1' kit) make a more mature impression. Here the entire box is made from plastic, and you are not limited to using fixed components and springs. The circuits are largely built on a breadboard area in the middle of the box.

A completely different approach is used with the kits from the German manufacturer Kosmos. The kit box consists of two hinged plastic sections, with room inside to store the components. The breadboard area consists of little tubes with spring tabs inside. The user can insert them (once only) into small holes in the kit box. Each tube has four holes into which component leads or interconnecting wires can be inserted. A sort of jig is located at the edge of the box for bending the leads of the included components and wires to the right length. Depending on the size of the kit system, the kit includes one box or two boxes that can be fitted together. Everything looks very 'technical', and it arouses an interest in experimenting.

For whom?

The relatively small kits are quite suitable for familiarising children with electronic circuits. To start off and see whether a child is actually interested in kits of this sort, it is good idea to buy one of the radio kits. They cost next to nothing (less than 10 pounds), and they provide a lot of hobby fun. After this, you can move up to a kit such as the 300-in-1 Electronic Lab or the Electronic XN1000. The larger kits from Maxitronix and Kosmos are most suitable for a budding enthusiast aged 15 or older who is seriously interested in electronics. In particular, the models with a breadboard area are handy for more advanced experiments because you can use them to build any desired circuit and you are not restricted to the projects or circuits described in the user's guide. All of the Kosmos kits use this approach, although the breadboard area of the smallest kit (XN1000) is rather small.

In any case, you should certainly buy an electronics lab kit for your children, because they're never too young to start learning. Maybe it will be the start of a fascinating hobby, or even a career in electronics!

(060338-1)

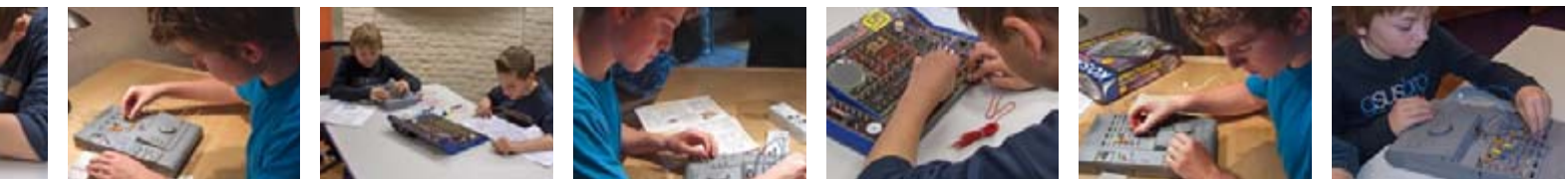

Electronic AM crystal radio

(approx. £ 7 (€ 9); 10 years and above)

A simple little kit for building only one project: a medium-wave (MW) crystal receiver. In contrast to the larger Maxitronix kits, here you have to assemble everything yourself, which means inserting the spiral springs in the holes, etc. After this, you connect lengths of wire between the springs as with the other Maxitronix kits. The special feature of this crystal receiver is of course that no battery is necessary. It draws its energy from the radio signal, which is naturally a special experience for beginners.



Electronic lab kit – AM/FM radio

(approx. £ 11 (€ 14); 10 years and above)

The second simple kit contains a more elaborate radio receiver suitable for medium-wave and VHF FM band signals. A fully assembled and aligned module is provided for FM reception. Here again you first have to attach all the springs and components to the base panel and then fit lengths of wire between the spiral springs to make the interconnections. A ear bud is used for signal output. This radio needs a source of power (in the form of a 9-V battery) because it included several transistors. A nice starter kit at a low price.



Electronic Lab 30 in 1

(approx. £ 19 (€ 25); 10 years and above)

This kit contains a base panel with components that can be used to build 30 different circuits. They include a ferrite-rod with a coil, a variable capacitor, several resistors and capacitors, two transistors, a diode and an LED, an audio transformer, a pushbutton, and a battery. The user's guide provides brief explanations of the operation of the various components, after which it gets down to business with connecting wires between the springs on the board to

put together specific projects. The initial projects are very simple, such as connecting the LED to the battery via a resistor. There are lots of circuits that generate sound, and the ubiquitous crystal radio circuit is also included. A miniature radio transmitter is also described. It's a bit of a pity that many of the circuits use the audio transformer, because this it makes it fairly difficult to understand how they work. The user's guide has an inconvenient format with a glued back that prevents it from lying flat. In light of the price, this is a fairly nice kit for beginners.



Electronic Lab 130 in 1

(approx. £ 45 (€ 60); 10 years and above)

The sample kit we received includes a user's guide in English and French. This shouldn't present any problems, although we doubt that your average 10-year-old will be able to do much with the French text. The construction is the same as with the previously mentioned kit, but the board is a good deal larger and there are more components on it. The most important additions are a loudspeaker, a 7-segment LED display, a slide switch, a potentiometer with knob, a CdS photocell, a dual opamp, and an IC with four NAND gates. The user's guide is generously dimensioned, and the descriptions are clearly worded. The projects are more sophisticated than the ones in the 30-in-1 kit, and beginners will find them relatively difficult to understand. For them, it would be better to start with the 30-in-1 kit and so acquire some experience with it before moving to the 130-in-1 kit. The projects in the 130-in-1 kit are divided into the following categories: entertainment, basic circuits, experimenting with the 7-segment display, digital circuits, oscillator circuits, opamp circuits, various radio designs, and test & measurement circuits. A nice kit with a large variety of circuits, but better suited to hobbyists who already have some experience.



Electronic Lab 30 in 1

(approx. £ 75 (€ 100); 10 years and above)

This kit has a different construction consisting of a plastic box containing various components with the familiar spiral springs. They include pushbuttons, potentiometers, a loud-

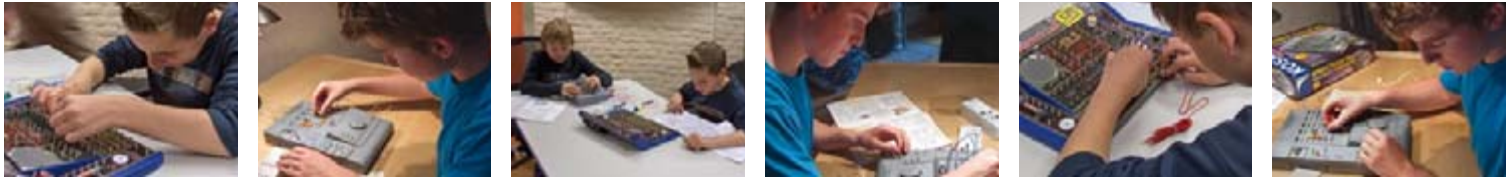

speaker, LEDs, a 7-segment display, a ferrite antenna, an audio transformer, a switch, and a

Electronic XN1000

(approx. £ 45 (€ 58); 8 years and above)

The approach taken with this kit from the German manufacturer Kosmos is completely different from the Maxitronix kits. The base panel consists of two plastic parts that must be partially assembled by the user. They are hinged together so the inside space can be used to store the battery, wires and components. You have to assemble the breadboard area yourself using miniature spring-steel tubes that are fitted in openings in the upper panel. Pre-stripped wires of various lengths are included. They must be bent to fit the hole spacing of the breadboard. The component leads also have to be bent to size. A sort of bending jig is provided on the box to make this easier.



The projects are described in story form. This is doubtless nice for small children, but older children will probably find the story form irritating. In addition, a lot of difficult terms are used, despite the generally playful approach. The attractive appearance and design of this basic kit with 100 projects will encourage anyone with an interest in technology to start experimenting. A well-conceived product.

Electronic Lab 500 in 1

(approx. £ 300 (€ 400); 10 years and above)

This kit is available from various Internet shops. One of its special features is that it includes a breadboard with a microcontroller, which certainly opens up a lot of possibilities.

The kit is built in the form of a suitcase box, with both halves completely filled with basic components and connector springs.



Several bags of loose components are also included. They can be used to put together circuits on the breadboard included with the kit.

Beside the analogue and digital projects included with the smaller kits, with this kit you can expand your knowledge of computer technology. It even has an LCD module and a keyboard for entering programs. Everything is explained in three user's guides – two for the hardware and one that deals with generating programs. The described projects range from super-simple to quite complicated. Even hobbyists with a fair amount of experience can make good use of this kit, and you can build very interesting circuits with it. The software portion provides an excellent introduction to programming in machine language.

Electronic XN2000

(approx. £ 85 (€ 110); 8 years and above)

This kit consists of two boxes (four half boxes) that can be fitted together to form a quite substantial system for experimenting with electronics. It supports a total of 236 differ-



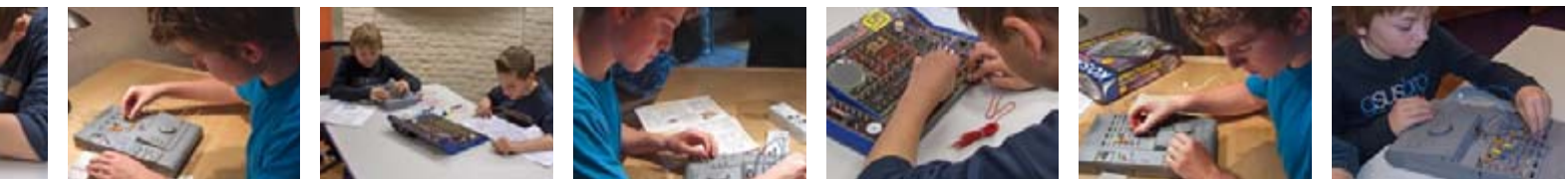

ent projects, although the number of components is very limited. Compared with the XN1000 kit, it has eight more passive components, a phototransistor, and an amplifier IC. Most of the additional scope is in the second box, which houses a loudspeaker and a potentiometer. The additional projects that can be built using this kit make extensive use of the opamp for driving the loudspeaker or an LED. Several relatively elaborate radio receivers are described. The style of the descriptions is the same as with the basic kit – here again, a group of fantasy figures guide you through the projects. This is a very nice experimenting system with a good variety of circuits.

ponents include a humidity sensor, a type 555 timer IC, a counter IC (4024), and a quad opamp (LM324). In contrast to the smaller kits, the user's guide is written in a completely different style. It is oriented to more mature 'future electronics specialists'. The explanations of how the various components and circuits work are also more extensive and detailed. For anyone who is genuinely interested in electronics and already has some experience, this kit provides a good guide to learning more about this fascinating subject.

Electronic XN3000

(approx. £ 125 (€ 165); 8 years and above)

This is the largest electronics lab kit from Kosmos, and the basic part consists of the same two plastic boxes as in the XN2000 system. An expansion set with additional spring clips, knobs, components, and even a genuine moving-coil meter increases the range of options. The additional com-



More kits (not just for kids)

Product	Supplier/Manufacturer	Website	price (rrp)
EL1301 electronic lab kit 130 in 1	Velleman	www.velleman.be	distributor(s)
EL3001 electronic lab kit - 300 in 1	Velleman	www.velleman.be	distributor(s)
EL301 electronic lab kit - 30 in 1	Velleman	www.velleman.be	distributor(s)
Explorer, Primary (Plus), Secondary	Cambridge Brainbox	www.cambridgebrainbox.com	£ 13-42
Electronics, grade 6-8	Foss	www.delta-education.com/science/foss/index.shtml	for schools
Locktronics Kits	Locktronics	www.tqlocktronics.com	for schools
Switch On!	Science Kit	http://sciencekitinternational.com	
Mr. Circuit Lab nr. I, II en III	Electronix Express	www.elexp.com	US\$ 26-62
Plugnlearn	Graymark Int.	www.graymarkint.com	US\$ 495
Introducing Electronics Technology	Techsoft	www.techsoft.co.nz	for schools
CD Electro Lab	Omnitron Electronics	www.omnitronelectronics.net	\$ 30
Radio and Electronics Lab	Omnitron Electronics	www.omnitronelectronics.net	\$ 30
200 in 1 Electronic Projects Lab Kit	Quasar Electronics	www.quasarelectronics.com	£ 45
500 in 1 Electronic Projects Lab Kit	Quasar Electronics	www.quasarelectronics.com	£ 150
Snap circuit boards SC-300; SC-500	Elenco	http://www.elenco.com/	US\$ 100\$; \$ 150
50-in-1 Electr. playground EP50	Elenco	http://www.elenco.com/	US\$ 25
75-in-1 Electronics lab MX-905	Elenco	http://www.elenco.com/	US\$ 34
130-in-1 Electronics lab MX-906	Elenco	http://www.elenco.com/	US\$ 51
200-in-1 Electronics lab MX-907	Elenco	http://www.elenco.com/	US\$ 67
300-in-1 Electronics lab MX-908 (= EL3001)	Elenco	http://www.elenco.com/	US\$ 81
500-in-1 Electronics lab MX-909	Elenco	http://www.elenco.com/	US\$ 203



collection

i-trixx

i-trixx is powered by





“Elektor? Fun in finding solutions for my electronics hobby. Never failed to impress my boss or my wife.”

– Thomas Gosling, 38, electronics enthusiast –

Electronics at all the right levels

Secure a head start in electronics with a subscription!

Advantages to subscribers:

- ✓ Cheaper than 11 issues from the newsstand
- ✓ Subscribers get up to **40% discount** on special Elektor products
- ✓ As a welcome gift you get a free **1GB MP3 player** worth £ 34.50
- ✓ No queues, travelling, parking fees or ‘sold out’ Elektor is supplied to your doorstep every month
- ✓ Always up to date – read your copy before everyone else



FREE 3-in-1 welcome gift: 1GB MP3 player, USB Stick and Voice Recorder

www.elektor.com/subs
Tel. +44 (0) 20 8261 4509

elektor
electronics worldwide

i-TRIXX collection

Assorted small circuits in a free supplement with Elektor magazine

For the second year round, we have gathered a varied collection of simple but useful and sometimes downright cute electronic circuits that you can build yourself, so that there's no excuse for being bored to death during the long winter evenings that are upon us. The 2006 i-TRIXX supplement was generally well received in terms of its educational value, contents and presentation, both by old hands at electronics and newcomers to the Elektor publication. The success story is continued this year.

Although the present i-TRIXX collection is again aimed at those of you starting out in electronics, or on a modest budget, scavenging components from the junk box, we know that the circuits presented also have an appeal if you just want to make something quickly in an afternoon or so. All projects are based on easy to obtain components or items normally thrown away as useless just because they are not state of the art (compared to 'what the neighbours have'). An i-TRIXX project is never complicated, big or difficult to understand, we hope! Plus, it can be soldered together in a spare hour or so. This free supplement contains a large selection of these types of circuits, pulled from the Elektor lab and from our large circle of free-lance contributing authors. If you would like to contribute to next year's 'dose', please let me know.

Much pleasant soldering!

Jan Buiting
Editor

www.elektor.com

Christmas flasher p4 | Water alarm p5 | Bio-feedback p6 | Thirst indicator for house plants p7 | Test beeper for your stereo system p8 | Light dimmer for torches p9 | LEDs show the way p10 | Electronic drumming p11 | Time for a game? p12 | Chip-canary p14 | Nervous spiral p15 | Tent alarm p16 | Silent dog whistle p17 | Lie detector p18 | Artful LED dimmer p19 | Failure detector for freezers p20 | A home-made battery p22 | Sensitive torch p23 |

collection

TRIXX

Christmas flasher

Have you already brought a Christmas tree into the house and decorated it with lights according to ancient Germanic custom? Improve the atmosphere some more by making one or more of your own Christmas decorations.

Colourful light emitting diodes (LEDs) flashing in an apparently random order and speed provide a festive scene.

Building this is a piece of cake because of a complete kit containing all the necessary parts, including the circuit board. This kit can be ordered via the Elektor website for a very reasonable price.

The circuit for the Christmas flasher is quite a simple design. A digital counter of the type 4060 (IC1) is used. This IC has a built-in oscillator, the frequency of which is set with resistor R1 and capacitor C1. With the values shown here this frequency is about 5 kHz. This oscillator signal is divided using various ratios by the internal digital electronics. These divisors are indicated with the letters CT on the IC symbol. So, for example, on output CT3 (pin 7) there will be a square wave with a frequency of 5 kHz divided by 2^3 , that is $5 \text{ kHz} / 8 = 625 \text{ Hz}$.

CT4 divides the oscillator frequency by $2^4 = 16$, CT5 by $2^5 = 32$, etc.

That means all these outputs toggle at their own rate.

The LEDs are connected in three groups between six of the counter outputs, resulting in 11 LEDs flashing with a seemingly arbitrary pattern.

The IC socket (note the marking!), both resistors, the capacitor and the battery clip are soldered on the triangular circuit board first. The eleven LEDs are next. Make sure you get the polarity correct: the short (or cut) lead is the cathode.

After a final inspection the Christmas flasher can be connected to a 9-Volt battery. A festive winking should be the result!

Design: Dieter Folger (Germany)

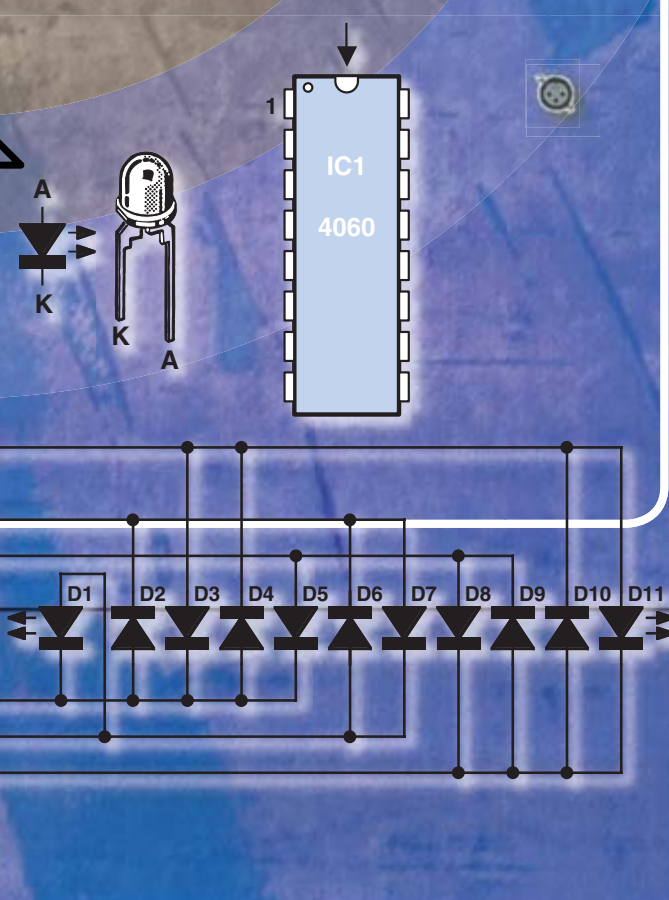
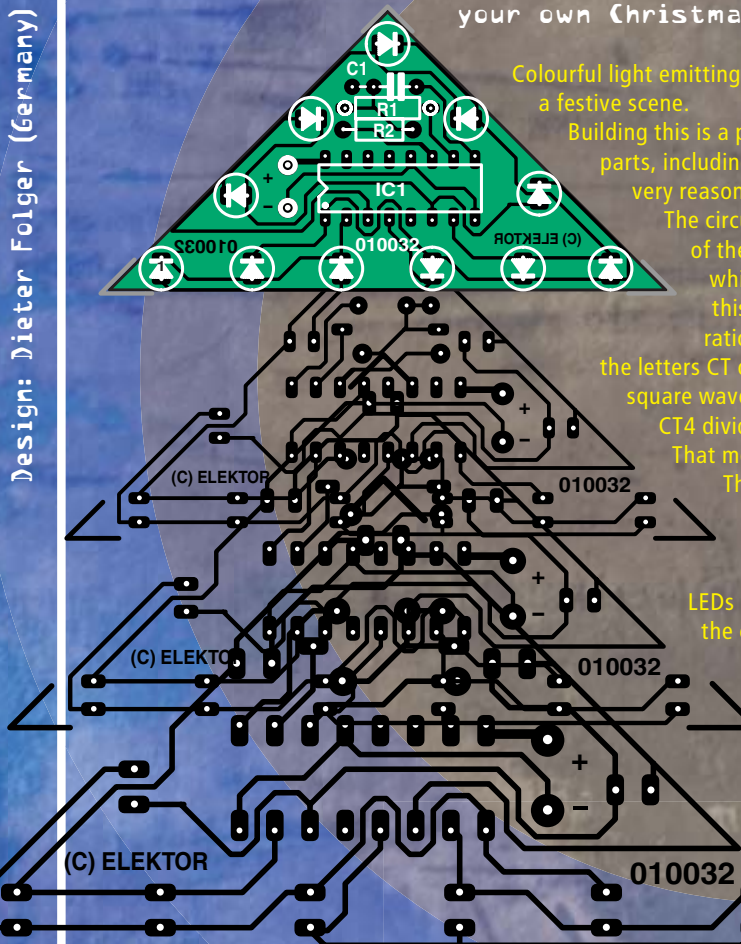

Water alarm

Have you ever witnessed the stairs to a higher floor transformed into a genuine waterfall? Or that the fish, next to the aquarium, are practising swimming on dry land? No? You certainly wouldn't want to, because the mess is incomprehensible. With a handful of electronics you can ensure that you are warned before things get too damp.

Flooding is better prevented than remedied! But despite the best precautions it is regrettable that sometimes it is possible that something will leak. A broken water hose to the washing machine, a forgotten bath tap, a broken aquarium window or a leaking boiler, any of these could happen. In any of these cases it is useful that you are warned as soon as possible, for example by means of an acoustic water alarm. That way you can at least attempt to limit the amount of damage.

This circuit uses the fact that 'ordinary' water is always, ever so slightly, polluted and therefore conducts current to a certain extent. This circuit is built around a popular IC from the old 4000 series logic: the 4093. This IC contains four inverting AND gates (NANDs) with so-called Schmitt trigger inputs. When water is detected between the sensors an intermittent and somewhat irritating alarm will sound. The conducting water is used to switch IC1a on. Two electrodes (sensors) are mounted at the lowest point the water will reach. These could be two tinned, copper wires, but two pieces of circuit board with the copper surface tinned will also work. IC1a forms, with resistor R2 and capacitor C2, a simple oscillator that generates the intermittent (on/off) effect of the alarm sound. If there is no water between the sensors, then the input of IC1a is held low with resistor R1 and the output of IC1b is also low. The oscillator does not operate in this state. When moisture is detected, the power supply voltage, via the sensors and conducting water will change input 1 of gate IC1a to a high level, which causes this gate to function as an oscillator. Each time the output of IC1b is high, the tone generator built around IC1c is activated, which in turn drives buzzer BZ1. In this way a rhythmical, on/off switching beeping noise is generated. The intermittent effect of the sound produced by the water alarm can be easily adjusted to your liking by changing the values of R2 or C2. With P1 you can adjust the pitch of the sound. The closer you are to the resonant frequency of buzzer BZ1 the louder the sound will be. This sound has to be adjusted to the most irritating level.

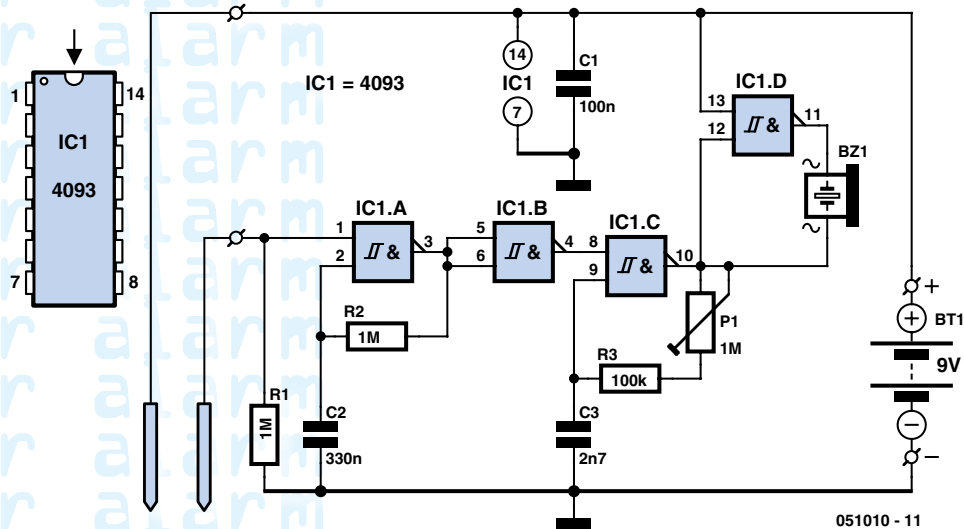

Gate IC1d is used to allow more power to be generated for the buzzer. IC1d inverts the output signal from IC1c and the voltage across the buzzer is therefore twice as much.

The circuit itself has to be mounted in a high and dry place, of course. Connect the electrodes (sensors) with two thin, twisted wires to the circuit. Be sure to use insulated and flexible wire. By twisting the wires, the (relatively long) connection between the sensors and the circuit is less sensitive to false alarms caused by electromagnetic interference.

The current consumption in the dry state is very small (less than 0.1 μ A). When the buzzer is activated the current consumption will be about 2 mA. With the frequency adjusted to the highest level we measured 3 mA. As long as no water is detected the battery will therefore last for years. However, in the long term there is a risk of leaking batteries...





Two-thirds of the higher educated can be reached for work via telephone, text or email while on holiday, according to recent reports in the media. Communication has become so easy because of technical developments that it can be easy to feel yourself morally obliged to be available at all times. Mobile phones and notebook computers have become standard items in our travel luggage. But what was the purpose of a holiday again? Yes, exactly, to relax! And if there is no other solution, then we can use technology here also to help us with this too.

You can be too hot when you physically exert yourself, but it can also happen when too much is demanded from your psychological powers. If, in the latter case, you are able to relax then this can be measured electronically based on the skin resistance. This resistance, as it happens, increases when you perspire less and the blood is less close to the surface of the skin (there is less need for cooling, after all). This phenomenon is put to good use in our electronic relaxer. It does nothing else than measure the electrical resistance between, for example your left and right hands, and translating it into a beeping sound. By relaxing yourself you lower the frequency of this sound.

You know it when you are (too) busy; perspiration is only one of the harmless physical symptoms of psychological stress, insomnia or increased blood pressure is less harmless. If you continue to ignore these alarm signals from your body, the sources of stress can build up, and you are well on your way to mental or physical exhaustion, with burn-out as the final consequence. A holiday can be an excellent method to take your mind off things and to interrupt the continuous state of high stress. But then you have to be able to switch off! You can train yourself in the operation of this 'switch'. The circuit presented here helps you with this.

The principle of this electronic relaxer is based on biofeedback. Feedback is also a well-known concept in electronics and in particular with control technology. In this, the output signal from an amplifier is compared with the input signal so that discrepancies in the shape of the output signal (distortion) are minimised by the action of negative feedback. Positive feedback is also a form of feedback, but in this case the differences between the input and output signal wave shape are reinforced. Feedback is an essential feature in, for example, an oscillator (the output signal sustains itself via positive feedback).

Our body also knows how to control certain functions via biofeedback. If we are too hot we will start to perspire, which cools us off, so the amount of perspiration can reduce again. With a good biofeedback control (and fortunately this is the case most of the time) the control system is nicely in balance. However, excessive or long-term stress can cause the system to become unstable (an amplifier becomes an oscillator or the other way around) and it's high time that you relax to give the system an opportunity to find its natural balance again.

Biofeedback

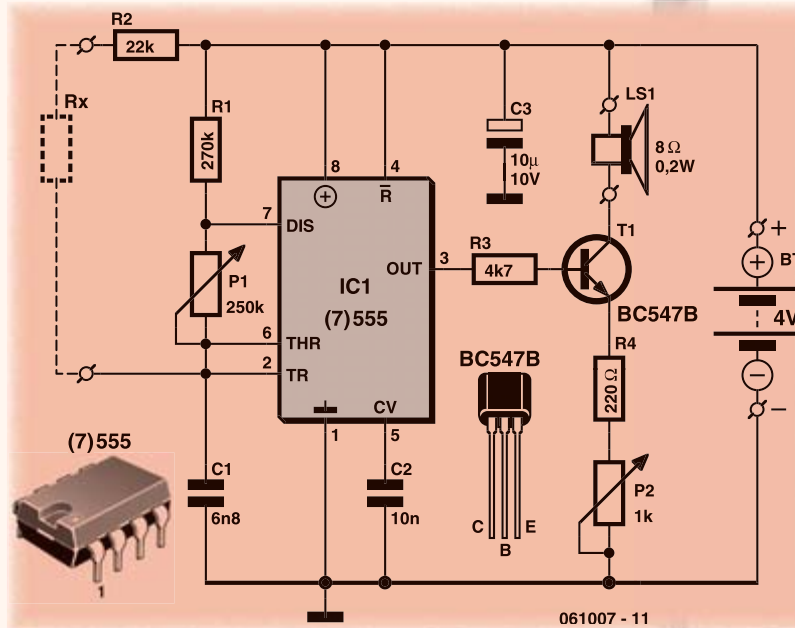

The circuit is built around the well-known 555 type timer IC (or the energy saving 7555). The resistor Rx, drawn with dashed lines, represents the electrical resistance of the human body. This body is connected via two sensors. You can, for example, use two metal rings which you put around a finger of your left and right hands. The rings are connected with flexible wire to the circuit; one to R2 and the other to pin 6 of the IC. Instead of rings you can also use metal rods of course, but holding them with unvarying pressure is less relaxing. Out of safety considerations, this circuit may not be connected to the mains (so don't use a mains power adapter).

To power the circuit, only use a 4.5-V battery or three 1.5-V penlight batteries in series (optionally rechargeable). Never make the power supply voltage higher than 6 volts (that is, 4 penlight batteries in series). Although this low power supply voltage is harmlessly low, we strongly advise against the use of the electronic relaxer by heart patients (in particular those with a pacemaker)!

The IC with the surrounding components have been designed such that the output results in a square wave, the frequency of which is in the audible range. Transistor T1 amplifies the signal and passes it to the little loudspeaker, which turns it into a beeping sound. The output frequency can be adjusted with P1 to suit your skin resistance. Choose a sound frequency that you find pleasing. You can adjust the volume of the sound with P2.

So what happens when you get tense? The skin resistance will drop and the result of that is a higher frequency sound. Now try to lower the beep frequency by relaxing yourself (think of peaceful scenes). This requires some training, of course; so do not give up too soon, and certainly do not get agitated if you fail to succeed at first. Getting wound up never serves any purpose, because it never changes anything to the source of the agitation and is only an obstacle to making the right decisions or thinking of good solutions. And if you understand that art of relaxation, then this will result in sufficient energy to survive the next period of stress intact. So plenty of practice, because practice makes relaxed!

i-TRIXX

Electronics inside out!

Thirst indicator for house plants

Watering house plants on time is not always an easy task for everyone. The watering can often only appears after the leaves are already looking a bit sad. Not every plant recovers from such a period of drought. With a handful of electronic parts and a spare hour you can build yourself an indicator that will give a timely indication with a flashing LED that the well-being of your house plants is in your hands.

An easy way to determine the moisture of the soil of a pot plant is to measure the electrical conductance of the soil with two electrodes. As the soil dries out, it becomes a poorer conductor between the two electrodes. To prevent electrolysis (decay or corrosion) of the electrodes, a pure AC voltage has to be used. The easiest way to make this AC voltage is to use a gate with a Schmitt trigger input as an oscillator. Here we used a 74HC132 (an IC with 4 NAND gates).

An oscillator (also called an astable multivibrator) has been designed around IC1A, the frequency of which is set to about 10 kHz. C1 is charged and discharged via R1, whenever a switching threshold of the Schmitt trigger is crossed and the output of the gate changes logic state. The electrodes are connected via capacitors (C2 and C3) to the output of the oscillator and the input of the second gate (IC1B) to make absolutely sure that the current through the electrodes is pure AC. In this way the soil of the plant conducts the signal from IC1A to IC1B. If the soil is sufficiently moist, the AC voltage at the second electrode is large enough to switch IC1B at the same rate as that of the oscillator (IC1A). The square wave output voltage of IC1B is rectified by diode D1 and filtered by capacitor C4 so that gate IC1C has a high level on both of its inputs and therefore a low level at its output. This low level ensures that the output of gate IC1D remains high and the indicator LED (D3) stays off.

IC1D is also wired as an oscillator. This oscillator comes alive (input pin 13 goes high) when the soil is too dry and therefore the AC voltage at the second electrode is too low. The correct level between dry and moist can be adjusted with P1, depending on the type of plant and soil, and the spacing between the electrodes.

The frequency of the oscillator built around IC1D is about 1.5 Hz. The result of this is a brightly flashing LED. D2 and R7 ensure that the LED is lit for only 20% of the period (and is therefore off for 80% of the time); it is therefore obvious when the LED is on, while at the same time the average current consumption from two 1.5-V batteries is reduced significantly.

The current consumption with a flashing LED amounts to about 1.4 mA. When the LED is off it is about 0.4 mA. With two penlight batteries the circuit will operate for about 300 days (we assume a capacity of 3000 mAh), provided, of course, that the plants are always watered in good time...

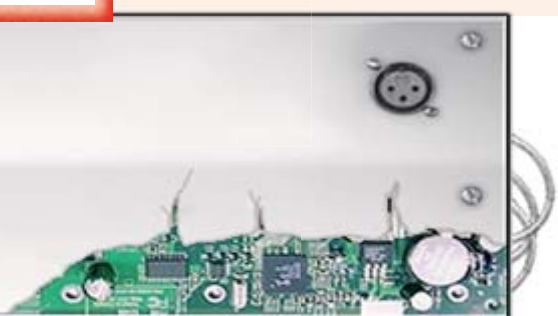
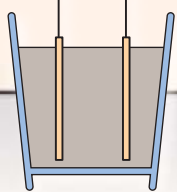
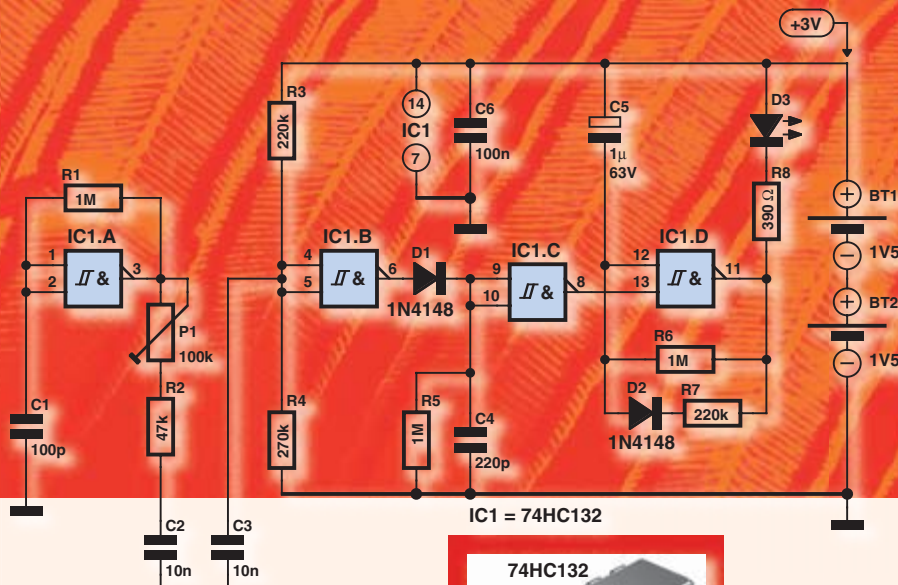

Test beeper for your stereo system

Has a channel from your stereo failed, or you don't hear anything anymore from your headphones from your MP3 player? It could be a broken wire or a bad plug, but also the internal electronics could have given up the ghost. With this test beeper you can quickly find out.

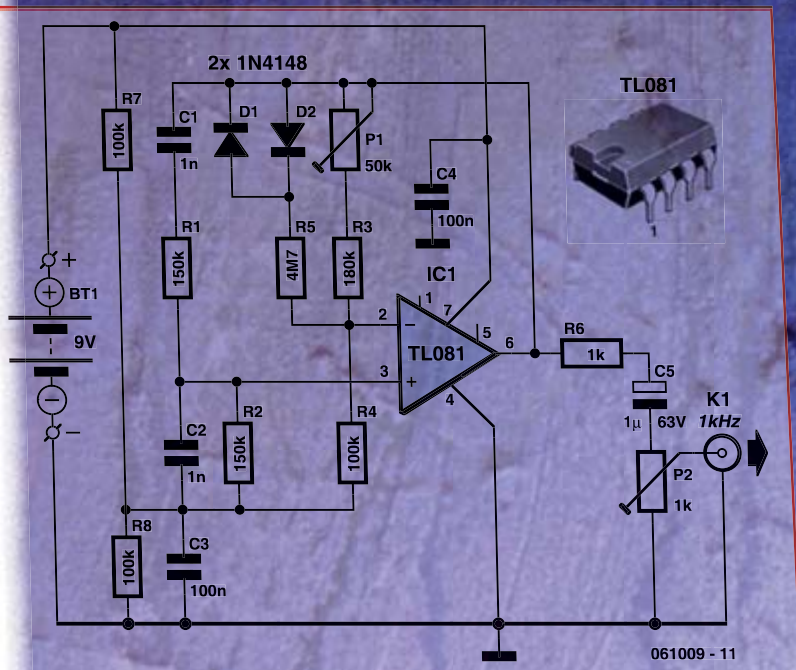

The test beeper presented here generates a sinusoidal signal with a frequency of 1,000 Hz, a common test frequency for audio amplifiers. The test signal can be directly connected to the input of an amplifier or via the suspect cable. You can then wiggle cables and plugs in an attempt to locate a potentially bad connection. Swapping cables around sometimes helps as well. The test beeper can also be used as a signal injector when looking for faults in amplifier stages. For this you 'inject' a test signal, for example starting at the input, directly into the amplifier and progressively move the injection point towards the output until the test signal becomes audible; the location of doom is quickly found in this way. If you are going to use the test beeper as a signal injector then it is recommended (to prevent a potential overload of the electronics to be tested) to connect a resistor of at least 10 kohm in series with the output.

The test beeper consists of a classic Wien-Bridge oscillator (also known as a Wien-Robinson oscillator). The network that determines the frequency consists here of a series connection of a resistor and capacitor (R1/C1) and a parallel connection (R2/C2), where the values of the resistors and capacitors are equal. This network behaves, at the oscillator frequency (1 kHz in this case), as two pure resistors. The opamp (IC1) ensures that the attenuation of the network (3 times) is compensated for. In principle, a gain of 3 times should have been sufficient to sustain the oscillation, but that is in theory. Because of tolerances in the values, the amplification needs to be (automatically) adjusted. Instead of an intelligent amplitude controller we went for a somewhat simpler solution. With P1, R3 and R4 you can adjust the gain to the point that oscillation just takes place. The range of P1 ($\pm 10\%$) is large enough to cover the tolerance range. To sustain the oscillation, a gain of slightly more than 3 times is required, which would, however, cause the amplifier to clip (the 'round-trip' signal becomes increasingly larger, after all). To prevent this from happening, a resistor in series with two anti-parallel diodes (D1 and D2) are connected in parallel with the feedback (P1 and R3). If the voltage increases to the point where the threshold voltage of the diodes is exceeded, then these will start to conduct slowly. The consequence of this is that the total resistance of the feedback is reduced and with it, the amplitude of the signal. So D1 and D2 provide a stabilising function. The distortion of this simple oscillator is around 0.1% after adjustment of P1 and at an output voltage of 100 mV (P2 to maximum). You can adjust the amplitude of the output signal with P2 as required for the application. The circuit is powered from a 9-V battery. Because of the low current consumption of only 2 mA the circuit will provide many hours of service.



i-TRIXX

Electronics inside out !

Light dimmer for torches

Light dimmers these days are not a curiosity anymore; every home improvement store, Wall-Mart or B&Q has at least a few models on their shelves. A light dimmer for a torch, however, is something that you will not find all that quickly. Such a controller can nevertheless be very handy: a battery-saving, dimmed light when reading or for mood-lighting in a tent when camping, or maximum light output when required. And if such an energy-saving light dimmer cannot be bought, then why don't we just build one ourselves?

You can, of course, reduce the output from a torch by connecting a resistor in series with the lamp. If you select resistors with several different values you can adjust the brightness of the lamp in several steps. Such a control does not make particularly efficient use of the (rechargeable) batteries in the torch; after all, a considerable amount of electrical energy in the form of heat is wasted in the series resistor. In particular when we, as campers, choose to pitch our tent far from the civilised world (and power points), we obviously have to be as frugal as possible with the limited energy in the batteries of our torch. This is easily done with a little electronics.

Ordinary mains light dimmers also use as little energy as possible. Not only to prevent the waste of energy but also to limit the heat generated by the dimmer itself. The latter is very important when dimming incandescent lamps connected to the mains, if we would like to avoid scorched wallpaper. The ubiquitous light dimmer for incandescent lamps regulates according to the on/off principle. The mains voltage is passed completely for part of the time and blocked completely for another part. This happens at the same rate as the frequency of the mains. In this type of control there is (nearly) no electrical energy lost in the form of heat.

We can also make such a low-loss on/off control for the DC (= battery voltage) powered torch. The controller ensures that the battery voltage is switched on and off at such a high rate that it appears to the eye that the lamp is on continuously. The lamp itself, because of the filament's slow reaction, also contributes to averaging of the on/off switching. By varying the ratio between the 'on time' and 'off time' we control the amount of light from the lamp in an energy efficient way.

For the fast on/off switch we use the familiar timer IC type 555. Specifically the CMOS version of the original NE555 is used, called TLC555 because this version uses less current. Even though this IC has a lower output current rating this is not a problem here, because an additional output transistor is used (in this case a FET) to drive the lamp. A BS170 was chosen for this transistor, which can deal with a lamp current of 500 mA without any problems. For larger applications you will have to use a real power MOSFET such as a BUZ11 or similar. With these make sure that the battery voltage is sufficient to ensure that the MOSFET is turned on properly; some types may require more than 4 V on their gate!

The 555 is configured here as a squarewave oscillator. A squarewave-shaped voltage appears at the output (pin 3). Differing from the standard application is the addition of diode D1. Because of D1, two different times can now be adjusted independently. The amount of time that the output is logic High is determined by R1 and C1 and amounts to about 0.8 ms. The time the output is low is determined by R2, P1 and C1 and can be adjusted with potentiometer to a value between 1.9 ms and 36 μ s. The duty cycle (the ratio between on and off) can be adjusted from 30% to 96% with these part values. Dimming to less than 30% has little merit because the light output will be too low to be useful in practice.

The operating principle of the circuit also causes the frequency to vary. At 30% the frequency is about 370 Hz and at 96% about 1.2 kHz. But that doesn't matter of course, both for an incandescent lamp and our eyes. The circuit is obviously powered from the batteries in the torch. Without a lamp the circuit, at a battery voltage of 6 V, consumes only 170 μ A and at 12 V, about 280 μ A. (If an NE555 were used instead of a TLC555 this current consumption would be considerably higher!) The low current consumption of the circuit itself can be neglected compared to the current consumption of the lamp and the circuit therefore

has practically no influence on the life of the batteries. The fact that the maximum setting is only 96% has the pleasant side-effect that the lamp will have a much longer life expectancy.

To test the circuit we used a lamp rated at 6 V/50 mA. At full brightness the voltage across the lamp was 5.66 V and current was 49.5 mA. At minimum brightness this voltage was 1.71 V with a current of 19.6 mA. Both the measured voltages are a little lower than expected from the duty cycle, but don't forget that T1 is not an ideal switch and a small voltage is lost across it.

First build the circuit on a piece of prototyping board (experimenting PCB) and connect the lamp from the torch by itself. Only build the dimmer into the torch when everything works properly! First trace the connections from the batteries to the lamp and on/off switch. Because it is usual for the switch and/or the lamp holder to be permanently connected with ground (the electrically conducting metal housing of the torch) it can be a bit of a puzzle to obtain the correct connections with the switch. It is easier if you fit a separate miniature on/off switch in the housing for the torch and connect it in series with the batteries with two separate wires. Use a small piece of double-sided PCB that you place between the battery and the ground spring (if there is more than one battery in the torch you can place the PCB between two batteries; it doesn't matter between which, as long as it ends up in series with the batteries). Solder the wires to each of the copper surfaces (i.e. those that are electrically separated from each other). Both wires are now connected to the new on/off switch. Now connect the lamp from the torch to the circuit. Make sure there are no electrical connections between the lamp holder and the other parts of the torch (change the mounting of this holder if necessary) and connect the lamp with two wires to transistor T1 and the positive of the battery (or the series connected batteries).

Use a miniature version for the potentiometer (P1) and mount it in a convenient place and connect this to the circuit with two wires as well. Once you've connected everything correctly you can adjust the light output from the torch between mood light and search light.

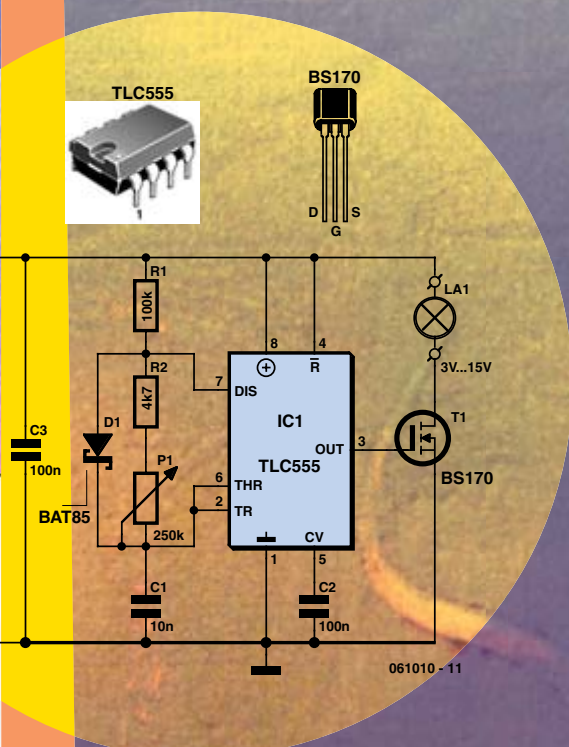

LEDs show the way

In dark places in particular, an illuminated direction indicator can be a handy aid. We're not referring to the turn indicators on your car, motorbike or scooter, but merely an illuminated sign that, for example, directs you to the exit of a building. With only one IC, 18 LEDs and a few resistors and capacitors you can build a prominent indicator that shows the correct direction in the form of running LED arrows. In this way no one will miss the door to your house party, and afterwards, the outside door.

To indicate direction you could obviously just use an illuminated arrow or a flashing light, but it is much nicer of course if something moves in the correct direction. The idea, here developed into a circuit, was born when we saw an older circuit with a few LEDs in the shape of an arrow. The LEDs were driven as a running light with two ICs; a clock generator and a shift register. We immediately thought that this was a nice idea, but it should be simpler than that. And that that is indeed possible is shown by this circuit. Only three inverters with Schmitt-trigger inputs are used. That is only half of a 74HC14. The other three inverters (IC1D to IC1F) are, to prevent noise on open inputs, connected to fixed input voltages by connecting them in series with the first input connected to the power supply voltage. The inverters behave as level-changing switches (a High level appears on the output as a Low level), while the Schmitt-trigger behaviour ensures a clean switching transition.

The clock signal (the pacemaker for the running effect) is, just as with a standard oscillator, generated with a Schmitt-trigger inverter (IC1A), but instead of feeding back its own output, feedback is now connected to the output of the third (IC1C) of the three in series connected inverters. The output signal used for the feedback signal has the be of opposite phase, of course.

Six series connections of three LEDs each (arranged in the shape of arrows) are connected to the outputs, or more accurately, between the outputs of the inverters in such a way that only two of the six columns (arrow points) are lit with two extinguished columns in between. Each time the lit arrows move over by one column, so that it appears that the arrows run from right to left.

To make the arrow longer than the six columns drawn in the schematic, the additional columns are connected in the same order as the first. So the seventh column is connected in parallel with the first column (D16, D17 and D18), the eighth column in parallel with the second column (D13, D14 and D15), etc. Keep the number of columns limited to 15; more columns are too high a load for the inverters.

Once the circuit has been built, you can experiment with the clock speed if you like. This has an influence on the perception of the running effect. With a slightly shorter time (lower value for C1 to C3 or R1 to R3) the circuit appears to become a collection of flashing LEDs. Depending on your personal preference, another timing may be required.

Build the circuit with red LEDs of the high-efficiency type. With 9 columns the circuit does not quite draw 6 mA. This is quite easy to calculate, because the current for each column of LEDs is set to just under 2 mA, and 3 columns are turned on each time. If only 8 columns are connected then the average current consumption will be a little lower. The low current consumption of the circuit makes it possible to power it from batteries. Recent alkaline AA batteries often have a capacity of 2800 mAh. With four AA batteries in series (and therefore generate a power supply voltage of 6 V) the circuit will run continuously for nearly 20 days. In a permanent installation a modern switch-mode mains adaptor is preferable for the power supply.

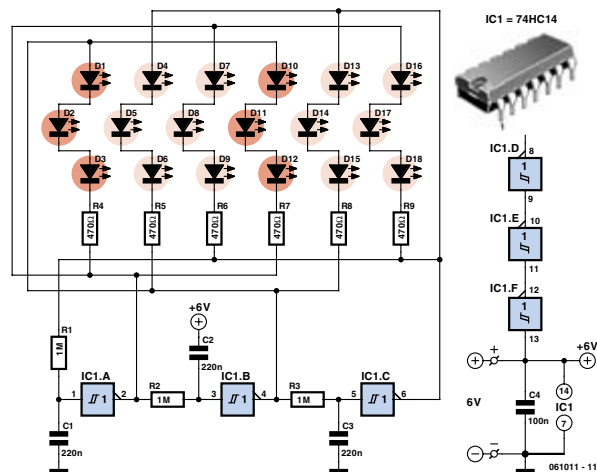

i-TRIXX

Electronics inside out!

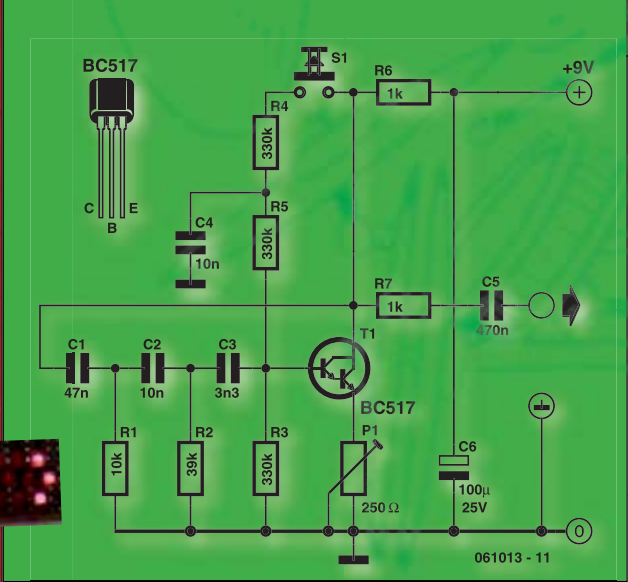

Electronic drumming

The sound of a drum is generated when a stick or hand hits a tightly stretched skin. This skin causes the surrounding air to vibrate which then sounds like music.

After the strong strike (attack) that brings the skin in motion, the sinusoidal vibration dies away slowly (decay). This wave shape can also be generated electronically by driving a loudspeaker with a suitable circuit. Such a circuit is shown here.

It concerns a simple phase-shift oscillator. This oscillator generates a nice sinusoidal signal. The resistors R1, R2 and R3, the capacitors C1, C2 and C3 and coupled to this network the resistors R4 (when S1 is pressed) and R5 and capacitor C4 ensure that the sinusoidal signal at the collector of T1 is changed in phase by exactly 180° and gets fed back to the base of T1. The signal at the collector is again phase shifted by 180° with respect to the base voltage so that the total phase shift is 0° and the circuit will oscillate when there is sufficient gain (which is the case here).

When you press push button S1, the oscillator generates a continuous sinusoidal signal, provided the gain is set correctly with P1. This gain has to be just right so that the oscillator just continuous to oscillate and does not decay. When S1 is released the oscillator will stop. Checking the oscillator is obviously the easiest (that is, without measuring instruments) by connecting the output to the input of your sound system. Take into account the fact that the circuit has an output signal of several volts, so start by setting the volume of the sound system to a low level (this saves speakers and ears).

So, by pressing switch S1 you strike the electronic drum. The pitch is determined by the oscillator frequency. With the component values shown in the schematic this frequency is around 240 Hz. Our drum sounds like a marimba that is being played with soft

sticks. If you would like to change the frequency and therefore the sound of the drum you need to change the values of C1, C2 and C3 up or down by the same ratio (higher values result in a lower frequency). You can also experiment with the value of capacitor C4 and resistor R4. For a slower decay, increase C4 and reduce R4 in the same proportion. When R4 is ratiometrically reduced even further this increases the attack of the oscillator and changes the sound to more that of a drum. Don't forget to adjust the gain again to its optimum setting.

The electronic drum draws about 4 mA of power supply current whenever it is struck. When S1 is not pressed the circuit draws practically no current: a separate on/off switch is therefore not necessary. You can use a 9-V battery for the power supply.

In the accompanying photograph you can see a piece of prototyping board we used to build the electronic drum. At the bottom left of the board you can see two sockets; this makes experimenting with different resistor or capacitor values much easier than repeatedly soldering and de-soldering!

If you would like to build multiple drums of different pitch, then you obviously need a correspondingly larger circuit board. Position the switches, for example, in such a way you can play them without moving your hand. Use microswitches that require a low force to operate and if necessary glue a larger striking surface to each switch.

The drum in earlier times was not only used as musical instrument, but also (if we're to believe the 'Indian stories'...) as a communications device to transfer messages quickly over large distances. Such communications go much simpler these days; you don't have to follow a difficult course in 'message drumming' and in addition you can send your message (if the servers decide to co-operate a little) around the world in mere moments, sometimes to the annoyance of those who didn't ask for it. In the current electronic age an electronic drum is more appropriate, not as a communication device any more, but solely as a musical instrument.



Your
time
starts
now!

"Your time starts now!" This is a phrase that is often heard preceding a contestant's turn in an exciting game show. An electronic timer serves as an aid to give each player an equal chance. With some games played around the table at home, such a timer can also avoid heated arguments. An i-TRIXX reader who apparently was keen to maintain good relations within his family asked us for a design of an easy to build game timer. Our Elektor lab got busy.

Time for a game?

The reader asked for a timer to be used with the game Rummikub. The circuit has to give some sort of indication when 1 or 2 minutes have elapsed. We started with this design brief, but the circuit is easily adapted if different times are required.

For the heart of this circuit we chose an IC that has been used in earlier i-TRIXX circuits, the type 4060. This IC makes it easy to generate extremely long times that can be set accurately. An LED (D2, a low-current type) is used to indicate that the timer is running and the power is switched on. A buzzer (BZ1) sounds when the game time is over.

Just a short explanation about the operation of the IC, a so-called binary counter with an internal clock oscillator. At its CT outputs there is a digital pattern of zeros and ones. At first all outputs are zero. It then runs through all the digital counter values (and that are quite a few with this 14-bit counter, 16,384 to be exact). This happens at a rate set by the RC network connected to pins 9 to 11. Since the indicator LED (D2) is connected to the internal clock oscillator, it flashes at the same rate of about 4 Hz. The way the IC is used in this circuit, the

counter will not reach its maximum value. When the switch S2 is in the '2 minutes' position, the counter will stop itself (via diode D1) the moment that output CT9 becomes high (logic 1). At the same time, transistor T1 (which serves as a buffer) will activate the buzzer. That obviously happens exactly 2 minutes after pressing the start button (S1). If switch S2 is in the other position then the buzzer will sound after 1 minute. Should the time not be quite right then it can be accurately adjusted with potentiometer P1 and comparing it with a stopwatch or the seconds hand of a clock or watch.

We deliberately kept the circuit as simple as possible (no additional power-on-reset network). So it is possible that when the circuit is first switched on, some arbitrary time between 0 and 1 or 2 minutes will elapse before the buzzer sounds. However, after pressing the start button (reset) the timer will run for the correct length of time. Incidentally, the length of time that the start button is held down has no influence on the selected time.

If you would like to be able to stop the timer before the time is up you can consider connecting S1 with the positive power supply instead of pin 12 of the IC. The counter will now be reset whenever S2 is pressed. Once you release the button the timer starts to run.

Besides Rummikub, the timer can of course be used with other games and applications that require an indication after a predetermined amount of time. The time can be shortened by a factor of 2 to half a minute by connecting output CT7 (pin 14) instead of output CT8; or lengthened by a factor of 4 from 2 minutes to 8 minutes by connecting output CT11 (pin 1) instead of output CT9 to switch S2. Note that the IC does not have an output CT10; lengthening the time from 2 to 4 minutes (factor of 2) is therefore not possible. If you need that length of time, then it is necessary to double the value of resistor R1 or capacitor C1. If you would like more than two different timer values then you can substitute a switch with more positions for S2 and connect its contacts to the desired CT outputs.

The current consumption of the timer – when running – is determined mainly by the flashing LED and mounts to less than 1 mA. The current consumption is obviously considerably higher when the buzzer is on. With the prototype we built, it was about 16 mA. For the beeper (buzzer) we used a round, axial, 12-V version.

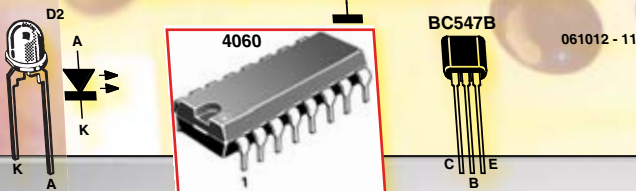
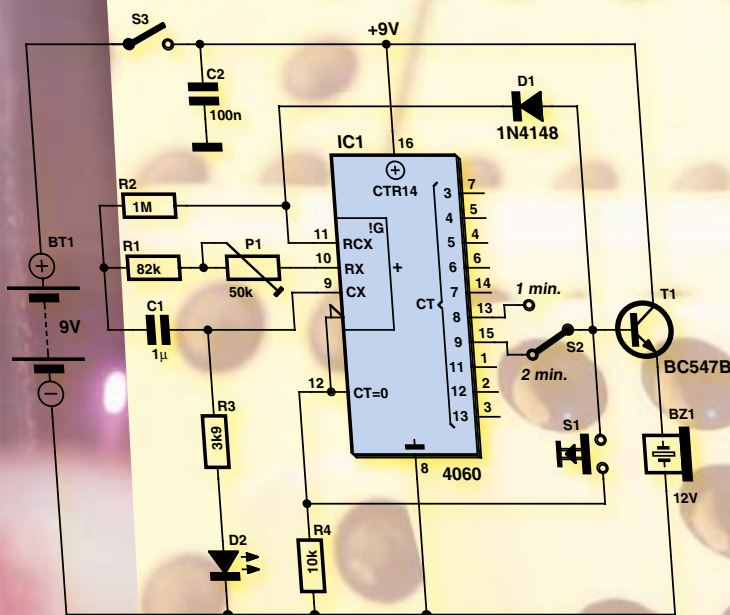

i-TRIXX

Electronics inside out!

Formula Flowcode Buggy

USB-programmable
robot vehicle (incl. CD-ROM)

Ready
to use
for only **£85.00**
US\$ 169.00

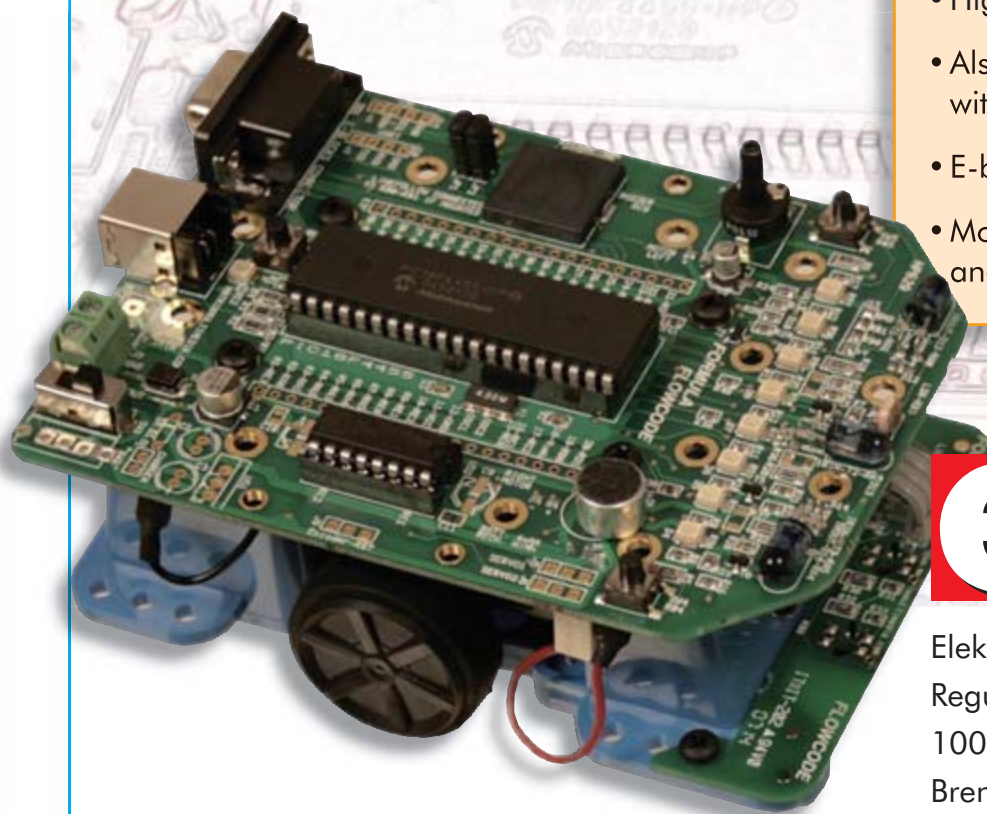

- A complete solution:
robot + software + curriculum
- Line following and maze
solving
- High-tech specifications
- Also programmable
with C or ASM
- E-blocks compatible
- Motivating for education
and hobby

elektor
electronics worldwide

Elektor
Regus Brentford
1000 Great West Road
Brentford TW8 9HH
United Kingdom
Tel. +44 20 8261 4509

Order quickly and safe through

www.elektor.com/shop

Chip-canary

Pets are nice; they provide pleasant companionship. Especially for those living alone, and those in nursing homes, a pet can provide a welcome relief from the mundane of daily routine. It is less pleasant when pets die, not a single specimen exempted. They tend to do that sooner if they're not looked after. Forgotten to feed the dog or the cat? Oh, they will definitely let you know, but the canary will sit there quietly until he drops off his perch. The chip-canary, built from electronics, will be spared this grief.

The silicon canary described here (*Serinus canarius silicinis*) is fed with batteries. An empty battery just means that the cheerful chirping stops; a fresh specimen will bring it back to 'life'. In this way feelings of guilt on the part of the owner are avoided.

The heart of this canary is formed by a chip, or more specifically, an IC type 4093, a quad NAND-Schmitt-trigger. This IC has already been used in other i-TRIXX circuits. With NAND-gates you can very easily build different types of oscillators. That is the case here as well.

Birds have a syrinx at the lower part of their throat, a vocal organ whose shape is changed by muscles and in this way produces different sounds. The syrinx is here emulated with three oscillators, built around gates IC1.A, -B and -D. Each oscillator provides its own part of the canary song. The individual oscillator wave shapes are combined by the surrounding components and produces an output signal that, when acoustically reproduced by piezo buzzer (Bz1), sounds quite similar to the cheerful chirping of a real, live canary. The oscillators obviously have to be properly tuned by ear first. Adjust potentiometers P2, P3 and P4 so the song from the chip-canary best resembles a real one. With three presets it takes a little while to obtain the closest true-to-life setting. P4 is used to move the entire frequency range up or down. P2 and P3 are then adjusted so that a realistic chirping can be heard.

To get this electronic canary to sing, it is enough to push switch S2. Depending on the setting of potentiometer P1 he will sing for a certain amount of time. Feed this canary with a 9-volt battery. To prevent the canary from eating the whole battery, you can turn the power supply voltage off with S1.

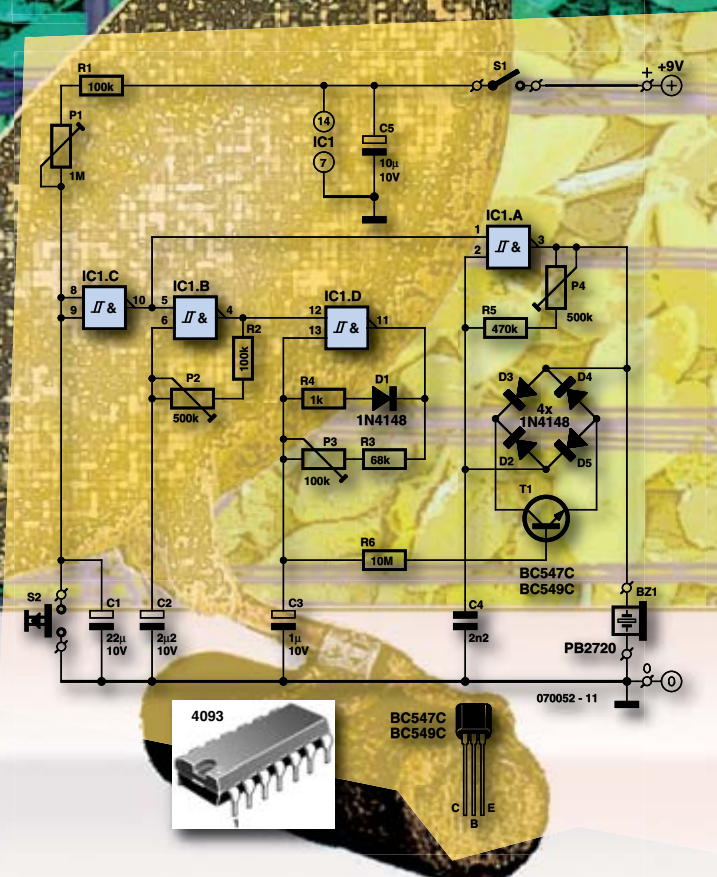

i-TRIXX

Electronics inside out!



Nervous spiral

Who hasn't seen one of these, or perhaps in this century we should ask: who still has one of these, that nerve-racking but exciting game where you have to move a metal ring along a twisted, metal wire to an endpoint without the two making electrical contact with each other? This requires a steady hand and nerves of steel. i-TRIXX helps you build an electronic referee for this game, which not only verifies whether the finish line has been reached, but also places a time limit on the duration of the game.

When playing this game you literally have to become a contortionist. The skill is to move the ring along the twisted wire from beginning to end. The ring is obviously not allowed to touch the wire along its path, because this is punished immediately with the sound of the buzzer to indicate that you have forfeited your turn. Dawdling too much will also end your attempt.

We have attempted to keep the electronic part of the game as simple as possible. So we haven't used, for example, an on/off switch; in the idle state the current consumption is negligibly small. The circuit comes alive when pressing the start button (S1).

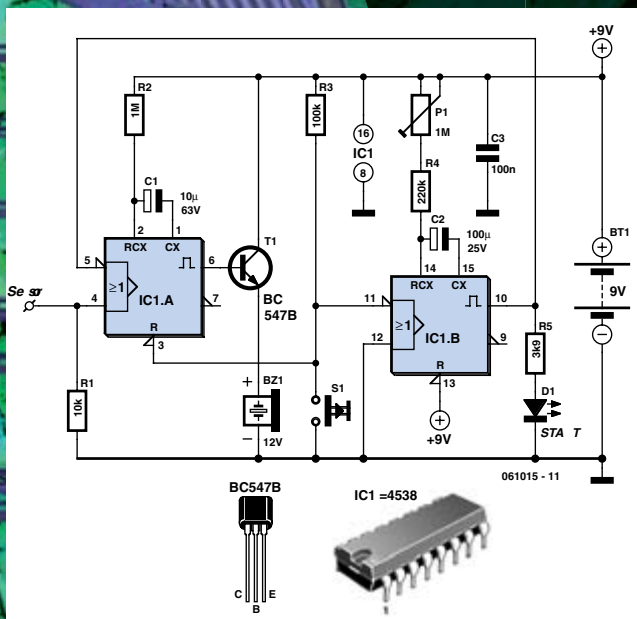

The circuit consists of only one IC (a 4538) that contains two timers. The first timer (IC1A) drives the buzzer for a limited amount of time, so that it does not continue to beep unnecessarily and irritate other players and spectators. We choose a duration of 10 seconds. This also reduces the current consumption of the circuit and since the power supply is provided by a 9-V battery this is a nice benefit. Because the outputs from the IC cannot deliver sufficient current to drive the buzzer directly, T1 is connected to the output of IC1A to act as a buffer.

The second timer IC2B determines the amount of time allotted to carry out your task. This time can be adjusted from 22 seconds to 2 minutes with the aid of P1. An LED (D1) is lit for the duration of your turn.

The timing durations for both the first as well as the second timer are easily changed to suit your needs. The duration is determined by an RC network connected to pins 1 and 2 of IC1A and pins 14 and 15 of IC1B. The length of time that the outputs of the timers are active is equal to $R \times C$. For example, for IC1A the time is: $1 \text{ M}\Omega \times 10 \mu\text{F} = 1 \times 10^6 \times 10 \times 10^{-6} = 10 \text{ seconds}$.

It is as easy as that! Always use good quality electrolytic capacitors (that means high leakage resistance) for C1 and C2.

The sensor (the ring) is connected to the positive trigger input (pin 4) of the first timer. Output pin 6 of the first timer goes High (= 9 volts) when pin 4 goes from Low (= 0 volts) to High, that is, when the ring touches the wire. The buzzer is driven via T1 and sounds the signal that the 'attempt has failed'. Pin 5 of this timer works the other way around; a low level starts the buzzer. This is used to drive the buzzer (the LED turns off) when the maximum game time (pin 10 of IC1B goes low) has elapsed. When you press S1, the first timer is reset and the second timer is started. Pin 6 of IC1A is now low and pin 10 of IC1B is high, with the result that the buzzer is silent and LED D1 is lit to indicate that the game is in progress. If the game time elapses before the player has reached the finish line, then the second timer will activate the buzzer and turn the LED off.

If the finish is reached within the allotted time, it is not necessary to wait until the time is up to start a new game. As soon as S1 is pressed the timers are back at their initial positions and a new game has started.

The circuit draws practically no current when the LED and buzzer are off. We measured less than $0.4 \mu\text{A}$. With only the LED on the current consumption amounts to slightly less than 2 mA. When the buzzer is activated and the sensor is connected with the wire (9 V) the current consumption is the greatest and that was a little over 17 mA in our prototype. We used a low-current type for the LED, which is quite bright at only 2 mA. The minimum voltage is mainly determined by the buzzer and our prototype continued to work when the power supply voltage was down to 4.4 V! The LED, however, was only dimly lit. To save on battery power it is possible to shorten the amount of time that the buzzer is on some more.

It is best to build the circuit into the enclosure that also supports the twisted metal wire. The beginning (start) and end (finish) of the wire is fitted with a small amount of insulation (electrical tape or sleeving, for example); the ring can then be parked without activating the circuit. Internally you connect the twisted wire with the positive terminal of the battery (which is also connected to the circuit). The metal ring is connected with a flexible (insulated) wire to the sensor input of the circuit (pin 4 of IC1A). Now you can check whether you possess a steady hand and nerves of steel.

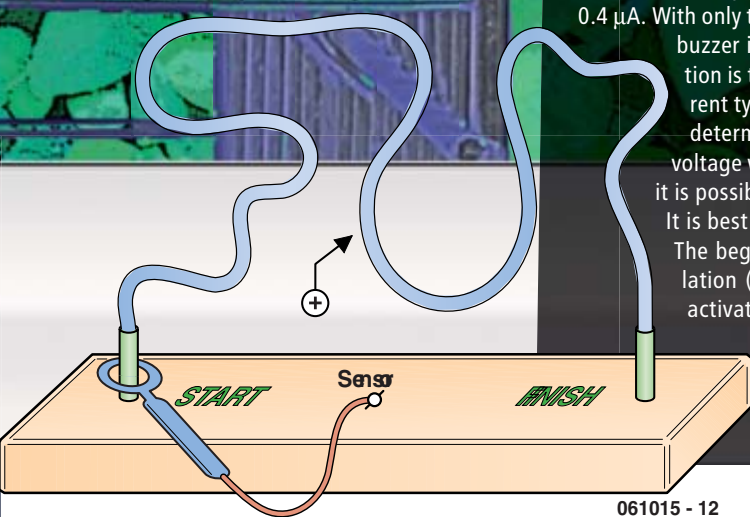

Tent alarm

It is quite difficult these days to protect a house from unwelcome guests, not to mention a tent! However, with a little bit of electronics it is possible to protect a tent reasonably well. It is of course not possible to completely prevent someone from breaking into a tent with an electronic tent alarm, but at least you and the other camping guests will be made aware when someone is in the process of wrongfully appropriating other people's property. Such a tent alarm is, of course, also handy when camping in, for example, the North-American wilderness to prevent a grizzly from joining you unnoticed in your sleeping bag.

The alarm described here is triggered when a wire is cut or broken. This wire is connected to the circuit at points A and B (see schematic).

The circuit itself is built around a single digital IC, type 4093. This IC contains a set of four NAND gates (IC1.A to D). The characteristic of such a NAND gate is that the output is only 'logic 0' (= 0 volts) when both(1) of the inputs are 'logic 1' (= power supply voltage); in all other cases the output is always 'logic 1'. Using that property, two square wave oscillators are built around gates IC1.C and IC1.D. The task of these two oscillators is to generate an interrupted beeping sound.

We explain the operation of the oscillator using gate IC1.D. When the alarm is armed with switch S1, the still intact and electrically conducting wire ensures that point A which is connected to pin 12 of gate IC1.D is at a 'logic 0' level (= 0 volts). As a result the output of this gate stays at 'logic 1'. This output will charge capacitor C1 (after a short while) via resistor R2 and trimpot P1 to a 'logic 1' level. The other input (pin 13) is thus at a 'logic 1' level. Nothing else happens. This state changes when the wire is interrupted. The input at pin 12 will become 'logic 1' because of resistor R1. Now both inputs of this NAND-gate are 'logic 1' with the consequence that the output toggles to 'logic 0'. The output will therefore discharge capacitor C1 which causes the input at pin 13 to go below the 'logic 1' level after a short time. (The Schmitt trigger characteristic of this type of NAND-gate ensures that the transition from '1' to '0' occurs without hesitation. Without this built-in characteristic there could be an undefined situation halfway, which means that faultless operation is not guaranteed.) Since one of the two gate inputs is no longer at 'logic 1', the output at pin 11 changes from '0' to '1'. Capacitor C1 is charged again and the whole process repeats itself. The output pin 11 now rapidly toggles between High and Low levels: we have a square wave.

A similar square wave oscillator is built around gate IC1.C. Because of the higher value of capacitance of capacitor C2 connected to the output (pin 3) of this gate now sounds an interrupted beeping noise: alarm!

The remaining fourth gate (IC1.B) of the IC is used for a nice technical trick. This gate delivers an inverted version of the output signal of gate IC1.A to the other side of the buzzer. The result is a doubling of the sound volume because the membrane of the buzzer now moves in the positive as well as the negative direction from its rest position. Without this trick the membrane would only move in either the positive or negative direction (depending on the polarity).

Now how to use the tent alarm in practice. Build the circuit on a piece of prototyping board and fit it complete with batteries in a 'camping-proof' enclosure. Make sure that the buzzer (a type suitable for 6 volts AC, for example the PB2720 made by Toko) can deliver its sound unimpeded to its environment. Adjust the frequency of the beeper with P1 so that its sounds the loudest. Adjust preset P2 according to your own liking.

Use a thin piece of insulated wire for the 'guard wire'. Connect one side of this wire to the circuit via a small plug and socket. The other side is directly connected to the circuit. The wire can now be woven through the tabs of the closed zips of the tent entrance. If the plug does not fit through the hole in the tabs you can attach (key)rings to them. If the zip is now forcefully opened then either the plug and socket will come apart or the wire will break. In either case the alarm will sound. If you would also like to keep grizzlies out of your tent then it is a good idea to protect more than the official entry into the tent. In this case you could stretch the thin wire around your tent with the aid of a few tent pegs. Position the wire far enough from your tent so that in the event of an alarm you have enough time to flee up a tree...

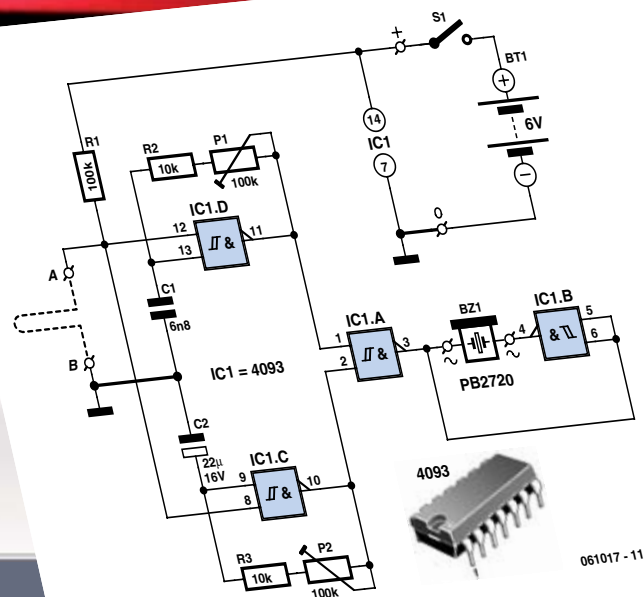

i-TRIXX

Electronics inside out!

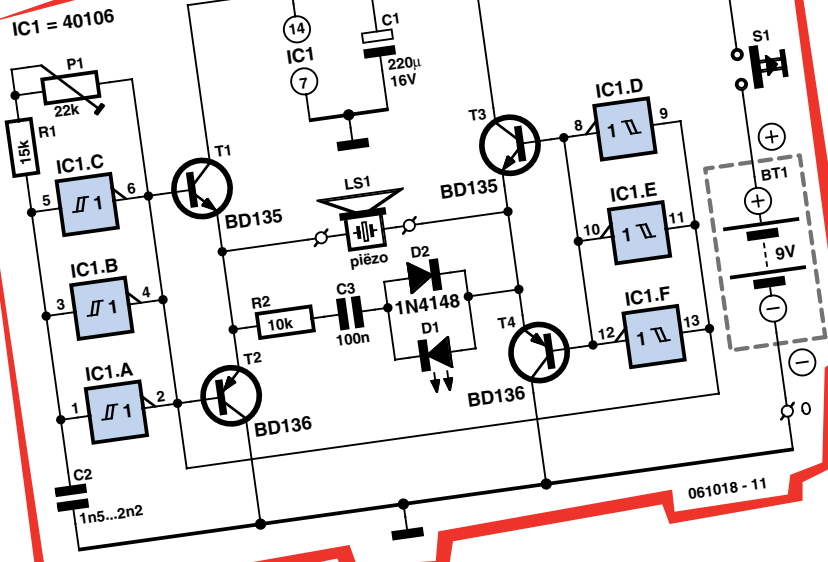
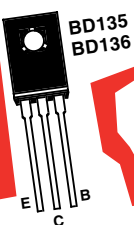
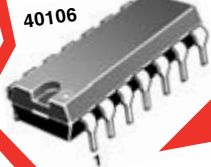

You see them, or perhaps better expressed, you hear them: dog owners who decide at too late a time to teach their (un)faithful companion some obedience. They scream their lungs out when Fido has decided to run off and, for the time being, refuses to return to its owner. And why would he? Running after other dogs is much more fun, isn't it? No, it is first necessary to teach him to return on command. This conditioning and response does not need to be accompanied with a lot of screaming. Certainly not when using with a, for other people inaudible, electronic dog whistle. We can build one with a handful of electronic parts.

Silent dog whistle

Canis lupus familiaris, the dog that is, possesses excellent hearing. Even though you may not suspect that when Fido, at the displeasure of his 'master' and amusement of bystanders, behaves as if he doesn't hear a thing. "Fido here, HEEEEERE... Bad dog, come here immediately!" None of it helps, Fido pretends to be deaf. Of course he hears his master call and plead, he just doesn't listen. During those moments some dog owners doubt the good ears of their unfaithful companion and try with abnormally raised voice to get the message across, with little result. It all has to do with the fact that the owner often does not understand that the dog does not comprehend spoken words. A dog, any dog, does not understand spoken language, any language. Words and their underlying meaning are wasted on the dog. He is better at dealing with clearly separate sounds and particularly when they are heard in the same (preferably happy) circumstances. Whistle to the dog and immediately give him a dog treat. After a few goes (depending on breed and individual) he will walk towards you when he hears you whistling. After a while you omit the treat, of course, otherwise Fido won't be able to walk because of obesity. It is important that we always sound the same whistle. If we suddenly let Beethoven's ninth symphony pass our lips then there is a good chance that Fido will look at us with incomprehension. With the dog whistle described here we can consistently generate the same sound. In addition, the circuit produces an ultrasonic tone which is not audible to humans but which a dog can hear. In this way 'calling' Fido is not noticed by others. The circuit also makes a sufficient racket to be able to call the dog back from a large distance.

The electronic dog whistle shown in the schematic consists of a piezo-tweeter (LS1, a high frequency speaker that can reproduce frequencies higher than 20 kHz), which is driven by a so-called bridge circuit. The bridge circuit actually consists of two switching stages, namely T1 and T2 on one side, and T3 and T4 on the other side. The switching behaviour is each other's mirror image (inverted with respect to each other). When the output signal on the left half is high (T1 conducts and T2 blocks) then the right half is low (T3 blocks and T4 conducts) and the other way around. When the bridge circuit is driven with a square wave, the full power supply voltage as applied across the tweeter, which alternates at the frequency of the square wave. The output volume is doubled because of this reversal. That is because the membrane in the buzzer moves both inwards and outwards from its rest position. Without this trick the membrane would move in only one direction (depending on the polarity), either inwards or outwards.

The bridge circuit is driven by the square wave oscillator built around gates IC1.A to IC1.C. The frequency of this square wave is above the human threshold of hearing and is determined by the RC-network P1/R1/C2. The left switching stage (T1/T2) is driven directly by this oscillator and the other stage via the, as buffer and inverter functioning, parallel connected gates IC1.D to IC1.F.

To prevent Fido from being punished unjustly because he does not react to the dog whistle any more while the blame should be placed on the empty battery, we have added a battery indicator in the form of an LED (D1). This LED lights up only when you press button S1 and the tweeter is driven. This optical indicator is necessary because we cannot, after all, hear the dog whistle. If the LED stays off then we have to replace the battery (and not the dog).

Build the circuit on a piece of prototyping board. For the power supply use a 9-V (rechargeable) battery. Suitable tweeters are, for example, types KSN 1001A or KSN 1005A.

You need to test the circuit before you can use it. Turn potentiometer P1 so that you can hear the whistle (if need be, increase the value of C2). You now know that the circuit generates sound. Obviously LED D1 should light up as well. Now turn P1 so that the sound becomes inaudible. If you are still young and don't have disco-ears, you may assume that other people won't be able to hear it either. If you've spent too much time in the disco or are not that young any more then ask the help of a young child, because a younger person can still hear high frequencies! Adjust P1 in such a way so that a young person cannot hear the whistle more. The dog still has to look up surprised when you press push button S1. This is a sign that everything works properly. Once the circuit is calibrated, the 'calibration' of Fido can commence. Don't hold the dog whistle too close, because the thing produces a lot of noise to his ears. He could run away never to return, and that was not why you built this! Start the training in your back garden (or at one of the neighbour's if you don't have one yourself); at least Fido can't escape this way. When the dog is far enough away, activate only the dog whistle and not your voice. If the dog shows an inclination to come towards you then squat down and encourage him by talking to him with a happy and high pitch voice. Reward him with a dog treat when he walks towards you (never walk to the dog!). Condition this behaviour by doing it often enough (obviously with rest breaks in between) before taking Fido into the street.

Lie detector

Do you know the saying 'Though the lie be swift, the truth overtakes it'? If you, based on the wisdom of practical experience, doubt the truth of this saying, then you place perhaps more faith in a lie detector. American judges do this; they accept the result of a lie detector test as supporting evidence. Fortunately there is a big stretch of water between the US and Europe!

If you would like to play CIA- or FBI-agent and subject people to a test of trustworthiness, using electronics, then you can build yourself a lie detector. An advance warning: doubt the indication of this device before you doubt the honesty of the person concerned, or you will be left with very few friends!

A lie detector does not give reliable results. That is the reason that European judges do not accept the device as evidence in a trial. Nonetheless it is interesting to experiment with one of these and hence the reason we present a simple, make-your-own, lie detector here. The electronic detection of a lie is based on the fact that various physiological reactions can be measured when a person lies. So there are changes (or said in a better way: there may be changes) in blood pressure, breathing, heartbeat, skin temperature and the amount of perspiration when a person adamantly lies. The circuit

presented here measures just the latter reaction: a change in sweat production, that is, a change in skin resistance.

The measurement of the skin resistance is done with the aid of two electrodes that are stuck a certain distance apart on the skin of the 'suspect'. The sensors can be made from, for example, small pieces of circuit board. Solder flexible wires to the copper side of the small plates and connect them to the lie detector. You stick the small plates with the conducting surfaces with bits of tape to, for example, the underarm. The skin has a certain electrical resistance between the sensors. If the 'suspect' feels uncomfortable with the questions asked then he will literally break into a sweat with a resulting change of skin resistance. This change is sensed by the lie detector and has to ring alarm bells with you, the questioner. To have any hope of 'reliable' results you have to ask simple questions and not something along the lines of: Is this the first time you have lied today?...

The schematic shows the electronic contents of the build-your-own lie detector. Since we want to measure small changes in skin resistance and not the

absolute resistance value, it is not sufficient to make a simple ohmmeter. The circuit filters only the change in skin resistance in gives a clear indication on the moving coil meter. The meter (M1) that is used here has a null position in the centre of the scale and can therefore indicate both an increase and a decrease of skin resistance (the scale itself is not important, only the movement of the pointer is relevant).

Since the skin has a resistance ranging from a few thousand ohms to several tens of kilo-ohms, the circuit is provided with a high-impedance input amplifier in the shape of opamp IC1. This opamp drives with its relatively low-impedance output both meter M1 as well as a second opamp (IC2). This second opamp has deliberately been made to react slowly with capacitor C2. Slow changes in skin resistance and therefore also slow changes in output voltage of opamp C1 are fed back through IC2 via R1 and P2 to IC1 with the result that the output voltage of IC1, and therefore also the meter deflection, hardly changes.

On the other hand, a fast change of skin resistance and therefore also the output voltage of IC1 is not compensated by IC2 (C2 effectively shorts-out fast voltage changes), so that the meter (M1) deflection indicates that the 'suspect' is feeling extremely uncomfortable.

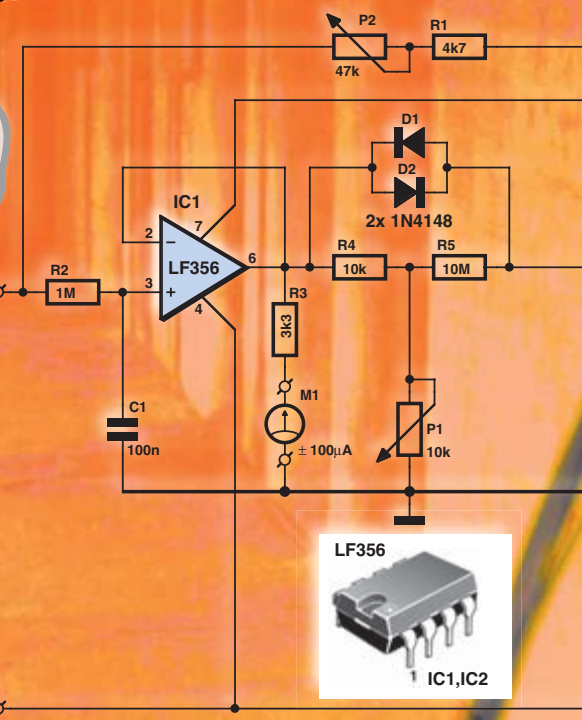

i-TRIXX

Electronics inside out!

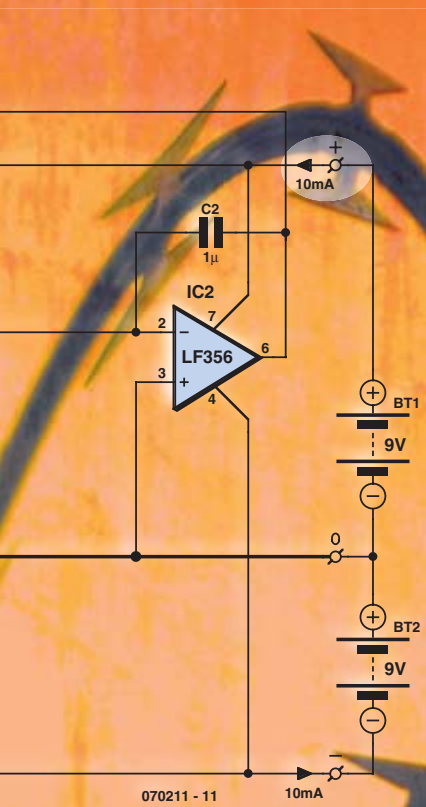

A remark about the meter. As already mentioned it has to be a (panel)meter with a null position in the middle; it has to be able to show a change in skin resistance, after all. The sensitivity of the meter is not very important. If you happen to have another type with a different sensitivity than the 100 μ A indicated then you just change the value of resistor R3 accordingly.

Don't use an electrolytic capacitor for C2. This type of capacitor has too high a leakage current for this type of application, which upsets the control system of this circuit. If you are unable to obtain a 1- μ F version then you could also use two 470 nF capacitors in parallel.

Instead of the in the schematic indicated types for IC1 and IC2 you can also use any of the following: LF355, TL061, TL071 or TL081.

In the interest of safety, the circuit may only be powered with two batteries of 9-volts each (so do not use a mains adapter!). Just to be extra safe, do not stick the sensors so that the heart region is between them. Also do not stick any sensors on the head. Although the current that flows through the skin is very small it is still better to avoid taking any risks. It is best to attach both sensors, for example, to one arm or one leg.

After the sensors are attached you have to first calibrate the circuit. Slowly (!) turn potentiometer P2 until the meter is in the centre position and indicates zero volts. It can take a while before the measured voltage settles down. The lie detector is calibrated once this is the case. Push a little on a sensor. If the circuit is functioning properly then this will cause the meter needle of meter M1 to move a little. You can adjust the sensitivity of the lie detector to your liking with potentiometer P1. You will, of course, set the sensitivity very low when you are yourself subjected to the lie detector by a friend!



Artful LED dimmer

Turning an LED only on and off? That's a very meagre use of all the possibilities that modern high-efficiency power-LEDs of 1 to 3 watts have to offer. With a low-loss dimmer you can have a nice continuous control of the light output. Take three power-LEDs of different colour, build three simple LED-dimmers and you can create a magical play of colours. While such a device is available ready-made, you can build one yourself for much less money with the benefit that you can make it just the way you want.

For certain applications it would be nice if the brightness of LEDs could be adjusted in a continuous manner. This is particularly true when, for example, you want to mix the colours from three different coloured LEDs. That can be done with the circuit described here, which you build three times for this application. If you use a slide potentiometer for P1 and position all of them next to each other then you can adjust the brightness by moving them together and change the colour mix by moving them individually.

The circuit (which you have to build three times for the suggested application) is built around the familiar timer IC NE555. Normally, the discharge connection, pin 7, is used, but in this application the time determining capacitor C2 is charged and discharged from the output (pin 3) via R1, P1 and both diodes (D1 and D2). The diodes make it possible to change the pulse/space ratio of the square wave at the output over a wide range from 0.5% to 99.5%. The frequency of the square wave remains quite constant throughout at around 1 kHz. Because of the persistence of vision of our eyes we cannot sense this fast on and off switching of the LEDs and we see a nicely averaged light output.

A MOSFET (T1) is connected to the output of the IC. When this FET is turned on it behaves as a very low resistance and can therefore switch a relatively high current without becoming too warm. It can drive a power LED (D3) with a maximum current of 1 amp without a problem.

Failure detector for freezers



Electrical appliances are expected to work; that is what they're made for after all! Technology will however let you down from time to time. Just one occurrence of water leaking from the freezer it is a small domestic disaster. An electronic failure detector could have warned you in time so that you could quickly move the perishable contents to a neighbour's freezer. You must of course not wait to build one of these detectors until the problem presents itself. We have to build it now!

The circuit described here is not only suitable for refrigerators and freezers, but can also be used to guard other, periodically or continually operating appliances operating from the mains, such as fresh air ventilators, pond pumps, etc. The circuit checks, based on the current drawn by the appliance, whether it is still doing its job or not. If no AC current is detected within an adjustable time period then an acoustic alarm reports that something is wrong.

To detect whether or not current is drawn from the mains by, for example, a freezer, we use the fact that there is a magnetic field around every current carrying wire. In the case of the AC mains this is an AC magnetic field. We pick this field up with a coil of a surplus low voltage relay (we used a 24-volt Siemens relay, type V23027-A0006-A101), which we take apart

until we're left with only the coil with internal iron core. By winding one of the current carrying wires (either phase or neutral) from the freezer around the core, a voltage is generated in the winding as a result of the electromagnetic field. Without making a dangerous, electrically conducting connection to the mains, we now have obtained a (magnetic) coupling between the freezer and our detector! But it can, and has to be, much safer still, because to be able to wind a conductor around our DIY current sensor we would need to strip the outer insulation from a short section of the freezer power cord. We obviously would leave the insulation of the individual wires (and that are 3 of them, including protective earth, PE) intact. A power cord with its outer sleeving partially removed could not be called safe any more, of course (the insulation is no longer what it was before).

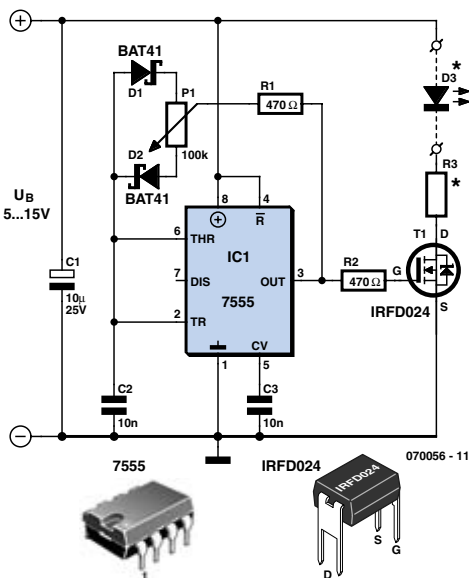

Because of its better accuracy and lower power consumption the CMOS type 7555 (or LMC555) is preferred for IC1. Also better are the Schottky diodes indicated in the schematic for diodes D1 and D2. They are only slightly more expensive than ordinary 1N4148, which could also be used.

A suitable power supply is a mains power adapter with regulated output. If the adapter is rated at 1 A, then you can power 3 dimmers with 1-W LEDs, or one dimmer with a 3-W LED. For three dimmers with 3-watt LEDs the mains adapter needs to be rated at least 2.1 A. Remember that the power LEDs need to be cooled. You can, for example, mount them on a length of aluminium angle profile (see photo).

With the value for R3 shown in the schematic and a power supply voltage of 5 volts, any arbitrary red, yellow or green LED (not power types) with a diameter of 3 or 5 mm (50-milliwatt types) can be connected.

The dimmer circuit can be built quite cheaply. The most expensive items are probably the slide potentiometers. You could also use cheap trim pots and adjust the brightness and colour mix of the LEDs in a more permanent way.

The circuit is really a little bit excessive when adjusting the brightness of a single small LED. It is different though when you want to connect multiple power-LEDs in series or create an artful effect with the mixing of colours, as you can see in the photo. This circuit is then much

cheaper compared to devices available ready-made.

The accompanying table is a handy aid when determining the power supply voltage and the value of resistor R3, depending on the number of LED's (=D3) connected in series.

	type	red, yellow, green	blue, white	Power LED	Power LED
		3 + 5 mm	3 + 5 mm	1 W	3 W
U _B	UF	1.9 V	3.7 V	3.4 V	3.5 V
	I	25 mA	25 mA	300 mA	700 mA
5 V	LED's	2 in series	1	1	1
	R3	47 Ω - 1/4 W	56 Ω - 1/4 W	5.6 Ω - 1 W	2.2 Ω - 4 W
7.5 V	LED's	3 in series	1	2 in series	2 in series
	R3	82 Ω - 1/4 W	150 Ω - 1/4 W	2.2 Ω - 1 W	0.68 Ω - 1 W
9 V	LED's	4 in series	2 in series	2 in series	2 in series
	R3	56 Ω - 1/4 W	68 Ω - 1/4 W	8.2 Ω - 4 W	2.7 Ω - 4 W
12 V	LED's	5 in series	3 in series	3 in series	3 in series
	R3	100 Ω - 1/4 W	36 Ω - 1/4 W	6.2 Ω - 1 W	2.2 Ω - 4 W
15 V	LED's	7 in series	3 in series	4 in series	4 in series
	R3	68 Ω - 1/4 W	150 Ω - 1/4 W	4.7 Ω - 1 W	1.5 Ω - 4 W

We solve this problem by using a type of enclosure which is readily available and has a built-in plug and socket (see photo).

We can take the plug of the freezer power cord and plug it into the enclosure and then plug the enclosure into the power point. The enclosure therefore ends up between the mains and the freezer.

Each of the three mains connections (phase, neutral and earth) of the plug is connected to the appropriate connection in the socket of the enclosure using appliance wire (2.5 mm²). One of the current carrying wires (not the earth!) is wound once or twice around the relay coil. Be careful that you do not damage the fragile coil winding (perhaps wind some insulation tape around the coil first). The actual current sensor is now finished.

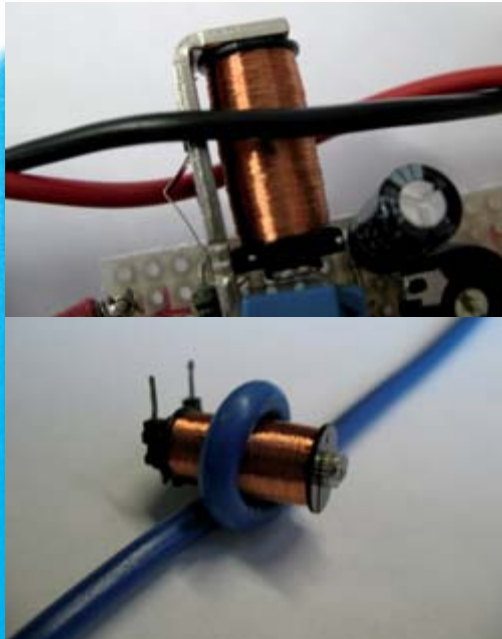

The only thing that is now missing, is the circuit that picks up the signal from the sensor and compare the presence of this with a predetermined time. If no current is detected within this time then we have an abnormal situation and the alarm sounds. You can find the circuit in the accompanying schematic. For safety reasons we fit the entire circuit in the enclosure as well!

RE1 represents the DIY current sensor. The remainder of the circuit is nothing more than an adjustable amplifier stage (around IC1A) and a voltage comparator (around IC1B). We used only one IC, a TLC272 which contains two opamps (more about that later). To drive the buzzer, a transistor (T1) is also added as a buffer.

To increase the signal level from the coil to a usable level, we chose a maximum gain of about 100. In our case the coil gave a peak voltage of about 17 mV when used with a 100-watt lamp. So this results in a peak voltage after amplification of 1.7 V. This voltage is rectified by diode D1

and filtered by capacitor C5 to a smooth DC voltage.

Once the previously detected current disappears and because of the large value of C5 it will take about 30 minutes to one hour before the output of comparator IC1B changes state and raises the alarm with the buzzer. We assume here that a normally operating freezer will turn back on within this time.

The guard time depends in the magnitude of the detected mains current, the coil used and the gain set with P1. If need be, the time can be made shorter by lowering the gain. A longer time is obtained by increasing the gain. If that is not enough, then the capacitance of capacitor C5 can be increased. (Use a high quality capacitor for C5.) A longer time is required to ride through the long period of a well-insulated

fridge or freezer when the compressor is off.

The trick is of course the get the circuit to check only whether the compressor of the freezer still runs on a regular basis and doesn't 'look' at any ancillary things such as indicator lamps, interior light and such. To make the circuit less sensitive to small currents it is possible to increase the value of R6 a little, but this has the consequence that the time duration is reduced somewhat.

For the buzzer we again selected a radial, 12-V type for PCB mounting, which still works well at a lower voltage. A pleasant side-effect is that the buzzer also draws less current at the selected power supply voltage of 9 volt. When the buzzer is active, the circuit draws about 12 to 13 mA at 9 V. When the buzzer is off, which in the ideal case will be always, then the current consumption is mostly determined by the power supply current through the opamp. We originally chose a TLC272 because it has a reasonably low current consumption. There are however also two special versions of this IC: an M-version and an L-version. If we use a TLC272 then the current consumption is 0.8 mA. With a TLC27M2 the current consumption is 0.17 mA and with a TLC27L2 the current consumption of the circuit is only 0.06 mA. When using the latter, a normal 9-V alkaline battery rated at 300 mAh will last 200 days. Using a 9-V mains adapter is also possible, in principle, but we advise against that, because when the mains fails you will be waiting in vain for an alarm!

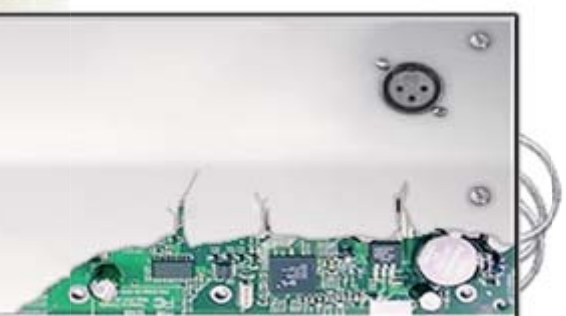
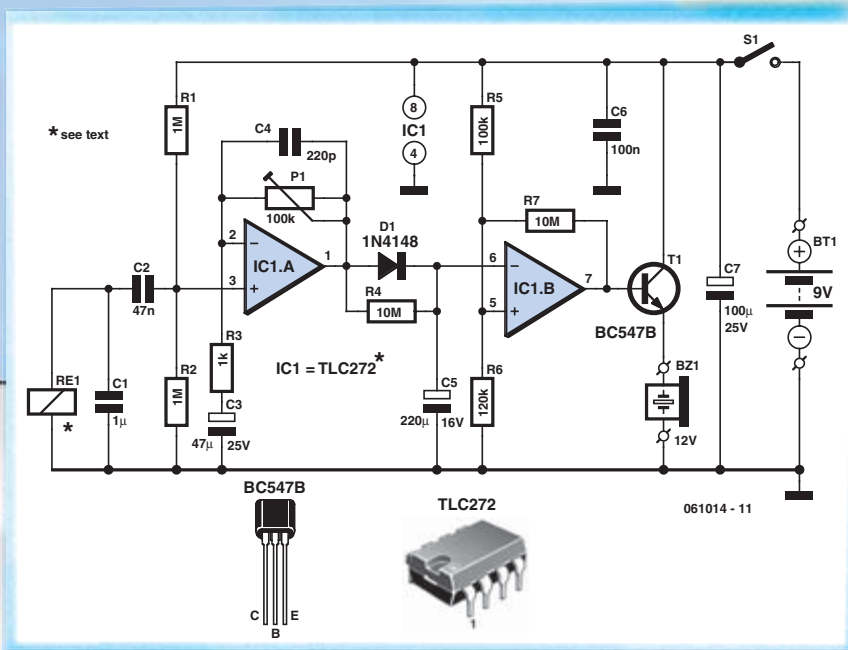

A home-made battery

You sometimes see them on websites or in the windows of shops selling gadgets: apples or lemons that serve as a battery power supply for small electrically driven mechanisms. But it can also be done without fruit. We here follow in the footsteps of Alessandro Volta (1745-1827) and build our own battery, which can also be used to clean copper or silver objects.

Electric voltage, including that from a battery, is expressed in volts and, indeed, this measure is derived from the name of Alessandro Volta, an Italian physicist who lived from 1745 to 1827. Volta continued to research galvanic electricity made by his compatriot and colleague Luigi Galvani (who was a medical doctor as well) in 1780 and built the first battery in 1800: the Voltaic pile. The pile originally consisted of 30, and later of 70, silver and zinc plates separated with cloth soaked in a salt solution. Volta himself called the construction an 'electromotor'.

We build a variant based on the battery principle: we replace soaked cloth with a glass of water in which salt and sodium carbonate are dissolved and substitute aluminium and copper for the silver and zinc plates. The advantage of the glass of water is that we can put in small copper or silver objects (jewellery) which are miraculously cleaned, but more about that later. Since one glass results in a voltage of only 1.15 volts, we immediately start with two glasses, so that with 2.3 volts we can demonstrate the operation of the home-made battery straight away with an illuminated LED.

Here is the recipe for the liquid in each glass:

- 1 teaspoon of table salt (available from the supermarket);
- 1 teaspoon of sodium carbonate (available from the same supermarket or from the chemist);
- as much water as fits in a glass of about 200 ml (available from the tap).

Stir the solution thoroughly so that the salt and sodium carbonate are completely dissolved.

In this solution we now hang a strip of aluminium foil with a width of about 4 cm and about 15 cm long. The easiest way is to fold the end around the top of the glass and hold it in place with a rubber band.

Now we strip a piece of flexible copper wire (mains flex) of the same length and hang it in the solution in the same way. Make sure that the copper and aluminium do not touch each other, otherwise our battery becomes short-circuited. If necessary, use a paper clip to press the foil to the inside of the glass.

The battery is now finished. Between the strip of aluminium and the piece of copper wire there is now an open-circuit voltage of about 1.15 volts, the copper is the positive terminal and the aluminium is the negative terminal.

As already mentioned, we make a second battery in the same way and connect it in series with the first: the copper wire of one glass is connected with the aluminium foil of the other glass (making this connection using copper wire does not matter). Soldering the wire to the aluminium will not work; clamp the stripped end of the connecting wire under the rubber band against the aluminium foil. We now have two free battery terminals: an aluminium terminal (the negative of the two-cell battery) and the copper terminal (the positive). Between these two terminals there is an open-circuit voltage of 2.3 volts, which we use to power a red (high-efficiency) LED. Connect, with a short length of wire, the short terminal of the LED (= cathode) to the aluminium negative terminal (clamp under the rubber band) and the long terminal (= anode) to the copper positive terminal. (When connecting the LED there is an easy to remember rule: the short or cut terminal is the cathode.) If you inadvertently connect the LED the wrong way around there is no danger of damage — the voltage is too low for that.

After the LED has been on for a while and therefore the battery has been used for some time, you will notice that the copper is nice and clean. This home-made battery is therefore eminently suitable for the cleaning of copper or silver.

We omit the LED as well as the copper positive terminal. Now we will not load the battery (one glass is enough) externally, but internally! The inside of the glass is now completely covered with aluminium foil and the copper or silver objects to be cleaned (which now function as internal negative terminals) are placed in the solution in such a way that they just touch the foil on the side (an internal short-circuit therefore). After a while they are as new! This is because an extremely thin layer is etched away from the outer surface. So don't forget to remove your clean silver jewellery, because after a while you may get the impression that a theft has occurred, without any traces of burglary...

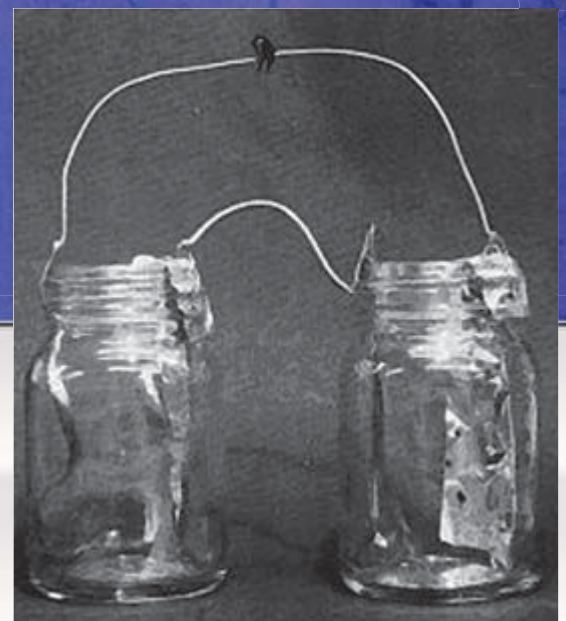

STRIXX

A sensitive torch? Yes, one that turns on as soon as you pick it up. This is particularly useful when you suddenly find yourself in the dark and you quickly need a light. Nervously fumbling for the on/off switch on the torch and then operating it, is time wasted. And forgetting to turn it off is not a problem any more either, because the lamp turns off when you put it down; that saves batteries. Can you buy such a torch? Perhaps, but you can make practically any torch touch sensitive.

Sensitive torch

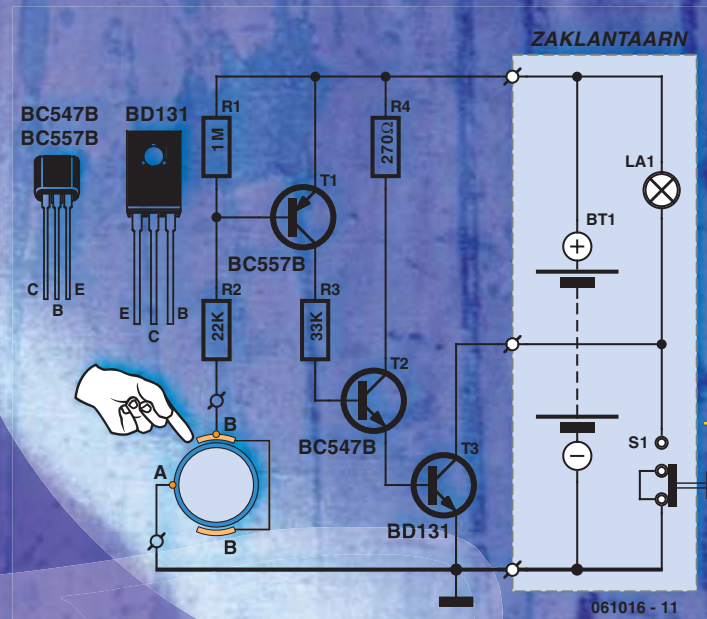

Some torches are usually switched on by turning part (the front or the back) of the housing. There are also types that are fitted with a slide switch. And then there are implementations with a push button. In short, it is a bit of a fumble in the dark when you haven't used the thing for quite a while. What can be easier than a torch which turns on as soon as you pick it up? If you know how to use a soldering iron and can tell the difference between a resistor and a transistor, then add some electronics to the innards of your torch and your torch is now also touch sensitive!

Fortunately, this does not require many electronic components. And that is a good thing, because finding sufficient spare space in a torch is hard enough. The accompanying schematic contains only three transistors and four resistors. With a bit of skill these can be mounted on a small piece of prototyping board and fitted onto the torch. There is possibly enough space behind the lamp. There may be enough space for a round circuit board (with a hole in the middle) behind the round lamp holder of a cylindrical torch.

The operating principle of the circuit is a touch switch, where the skin of your hand is used as an electrical resistance. We glue – in the case of a cylindrical torch – in the lengthwise direction, one or two long pieces of circuit board with the insulated side facing the outside of the metal(!) torch. Check that the outside of the torch is electrically conductive and not covered with an insulating lacquer (a chromed version or an aluminium one would be ideal, for example). The outward facing, electrically conducting copper surfaces of these small strips of circuit board form one side of the touch switch. Both of the copper surfaces are connected with a short wire to the circuit (point B in the schematic). The other side of the touch switch is formed by the metal housing of the torch itself, which is connected to point A of the circuit. Position the strips opposite each other; in this way at least one, together with the housing, will be touched when you pick the torch up!

When you pick the torch up, the skin of your hand will create an electrically (albeit weak) conducting connection between the copper surface of one or both strips and the metal housing. In the schematic (where we assumed two strips B/B) we can imagine this as a resistor between the connection A and B/B. This resistor activates the circuit. From the batteries on the torch, to which the circuit is connected, there now flows a very small (harmless) current through the base-emitter junction of transistor T1 via resistor R2 and the skin of your hand. This transistor will amplify and pass this current on to transistor T2, which amplifies the current some more and drives transistor T3 hard into conduction. The lamp (LA1) in the torch will now turn on.

The lamp turns off when we put the torch down. The circuit draws a negligible small (leakage) current; a separate on/off switch is not necessary. The original on/off switch (S1) is still available if we want to turn the torch on without having to hold it. This can come in useful in situations where you need both hands and a light.

The circuit is suitable for torches with a total battery voltage between 3 and 15 volts and a maximum lamp current of 2 amps.

A note regarding the mounting of the circuit in the housing: ensure that the metal cooling tab of T3 does not come into contact with electrically conducting parts of the torch. If your version of the torch switches the positive terminal (the polarity of the batteries is then opposite from that shown in the schematic), it is still possible to build the circuit, but substitute for T1 a BC547B, for T2 a BC557B and for T3 a BD132.

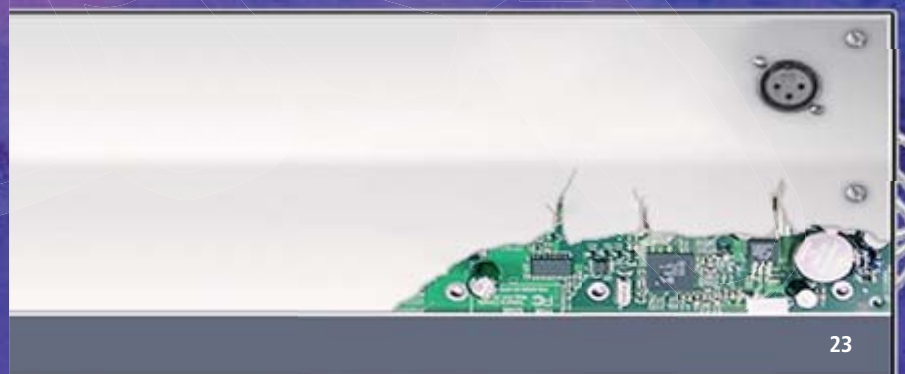

velleman[®] INTRODUCES

VELBUS

Home Automation System

Finally!

Here is no-nonsense home automation which is easy to install and to maintain, both for the qualified technician as for the DIY enthusiast. The system does not contain any (costly) central unit, which makes it extremely user-friendly, reliable and inexpensive. The VELBUS can be set up and controlled using the classic learning method as well as with a few clicks of the mouse through your computer. The necessary software is available for free.



Assembled and tested modules.



1-CHANNEL RELAY MODULE
VMB1RY
89€



4-CHANNEL RELAY MODULE
VMB4RY
149€



DIMMER MODULE
VMB1DM
95€



BLIND CONTROL MODULE
VMB1BL
79€



PUSH BUTTON AND TIMER CONTROL PANEL WITH
IR RECEIVER
VMB4PD
99€

+ FRAME VMBFLG
12€

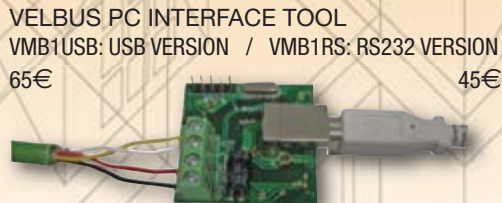

VELBUS PC INTERFACE TOOL
VMB1USB: USB VERSION / VMB1RS: RS232 VERSION
65€ 45€

IR REMOTE CONTROL STICK
VMBIRTS
49,5€



FREE "VELBUSLINK" PC SOFTWARE

8 PUSH BUTTON INTERFACE
VMB8PB
39,95€



To connect up to 8
any brand push-buttons

More modules on www.velbus.be

Price is indicative only // VAT included

For dealers see: www.velleman.be

cleverscope plug & play instruments

mixed signal oscilloscope and spectrum analyser

why is everyone talking about cleverscope?*



cleverscope CS328A

visit our website and discover for yourself

www.cleverscope.com

*quote: "unlike ordinary logic analyzers, I can now see vital analogue and digital details"

Build your own Robot!



Vex Robotics Kits

- Meccano Compatible • Computer Control
- Radio Control • Tank Treads • Hydraulics

FUN FOR THE WHOLE FAMILY!

"Imagination is more important than knowledge"
Albert Einstein



Internet Technical Bookshop, 1-3 Fairlands House, North Street, Carshalton, Surrey SM5 2HW

W: www.robotiq.co.uk E: sales@robotiq.co.uk T: 0208 669 0769

ANDRE LAMOTHE'S
XGAMESTATION
LEARN STEP-BY-STEP HOW TO BUILD AND DESIGN YOUR OWN VIDEO GAME CONSOLE!

Design inspired by the Atari 800/2600, Sinclair ZX Spectrum, Apple II & Commodore 64!

Parallax SX-Key Compatible!

INCLUDES:

- Tools, Demos & Utilities!
- Great for Hobbyists AND Students!
- The Fun Way to Learn Embedded Systems!
- Fully Assembled XGS Micro Edition Unit!
- Complete Software Development Kit!
- eBook on Designing the XGS Console!
- Cables and Power Supply Included!

WWW.XGAMESTATION.COM
PH: 925.736-2098 SUPPORT@NURVE.NET

HURVE NETWORKS LLC
400 DAMIAN ARROYO WEST
DANVILLE, CA 94506 USA

PEAK
electronic design ltd

tel. 01298 70012
fax. 01298 70046
www.peakelec.co.uk
sales@peakelec.co.uk

Handheld Test Gear - Cool, Smart.



Atlas DCA Model DCA55
Semiconductor Analyser



Atlas ESR Model ESR60
ESR and Capacitance Meter



Atlas LCR Model LCR40
Inductor, Capacitor, Resistor Analyser



Atlas SCR Model SCR100
Triac and Thyristor Analyser

UK: Please add £1.00 p&p to your order. Prices include UK VAT. Please see website for overseas pricing.

NEW! High Capacity Alkalines!
At Silly Prices!



Micromechanical Silicon G

MEMS gyroscopes in consumer ele

Stefan Tauschek

In financial terms micromechanical engineering is insignificant when compared to the multi-billion-dollar semiconductor industry; in technological terms, however, the progress being made in micromechanical sensors is enormous. Particularly commercially interesting examples of this are accelerometers and rotation sensors, also called gyroscopes. As manufacturing prices inexorably fall, so the number of applications rises.

While the semiconductor industry is constantly setting new records as it moves to ever smaller process geometries, and Moore's Law appears still to be holding, the commercialisation of micromechanical technology is still in its infancy. Although the manufacture of what might reasonably be called 'machines' on a microscopic scale is still some way off, considerable progress has been made in the miniaturisation of sensors for physical quantities, for example for acceleration and rotation. If these transducers can be made cheaply enough, the applications are practically limitless. Sensitive movement detectors are essential for devices such as portable navi-

gation devices that can work where GPS is not available, and for compensating for shake in video cameras. And, integrated into a console or into special clothing, they will bring a revolutionary new generation of virtual reality games.

Accelerometers and gyroscopes

Industry watchers expect that gyroscopes will be the 'killer application' for micromechanical technology in the next few years. There has already been a wide range of devices developed for the automobile market, of which the best known are stability control, navigation system backup and accident detection. These are generally aimed at the premium segment of the vehicle market, where cost is a less significant factor and budgets are larger. Now stability control is often fitted as standard in mid-range vehicles, and motoring organisations are recommending that it be fitted in small cars and vans. Consumer electronics applications include three-dimensional user interface devices, image stabilisation and games consoles, although because of the cost and physical size of the devices they have not been used in significant quantities. However, with progress in microelectromechanical systems (MEMS) reaching new levels of miniaturisation and suitability for mass production, these sensors are set to become much more widespread.

Miniaturised force sensors, such as accelerometers and gyroscopes, are among the most important silicon-based sensor devices, second in sales volume only to pressure sensors. Industry analysts believe that gyroscopes will reach a similar level of market penetration when the unit price for mass production falls below ten dollars.

Thanks to gyroscopes, the future also promises robots with improved agility; self-balancing vehicles (**Figure 1**) would be impractical without suitable sensor technology.



Figure 1. Devices such as the Segway depend on gyroscopes to balance themselves.

gyroscopes electronics

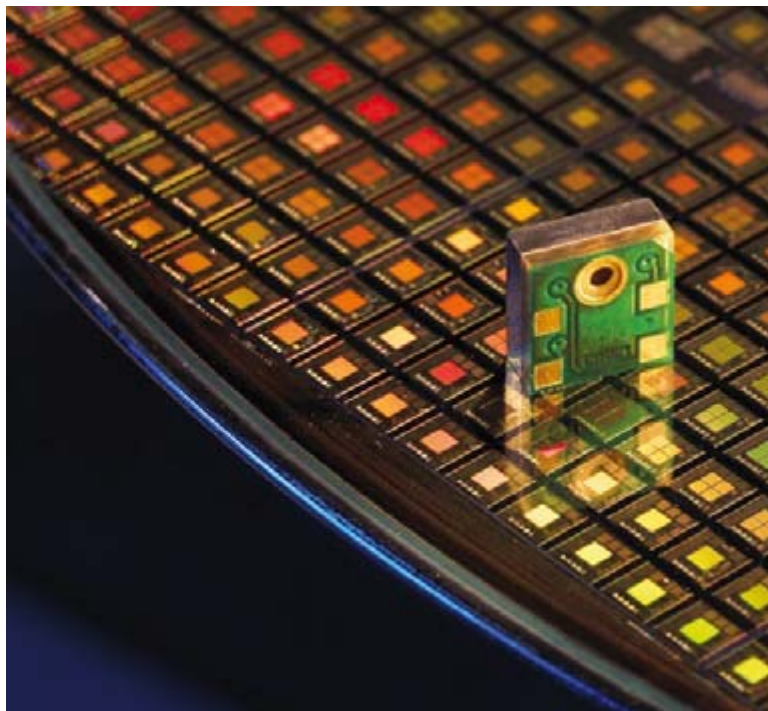

The gyroscope

A traditional gyroscope consists of a rapidly spinning symmetrical wheel supported in a gimbals arrangement. Since angular momentum is conserved the spinning wheel (**Figure 2**) resists changes to its orientation when the external frame is rotated. This property makes it useful in active attitude control applications, especially in aeroplanes and spacecraft.

Practically every aircraft cockpit will feature several gyroscopes. The most important of these is the artificial horizon (**Figure 3**). This displays a line to the pilot which is set to horizontal at the start of the flight. Because the axis of the horizon gyroscope remains fixed this line remains horizontal even if the aeroplane tips forward or backward or from side to side ('pitch' and 'roll'). The spatial orientation of the aeroplane can therefore be determined in the cockpit if darkness or cloud prevent visual determination or if centrifugal forces impair the pilot's sense of balance when changing course.

Acceleration and rotation

Alternatively we can think of gyroscopes as measuring a rotation or angular acceleration of the external frame of reference relative to the rotating mass, in a way that is essentially independent of gravity. This gives them a significant advantage over linear acceleration sensors, whose outputs (depending on their orientation and movement) must be compensated for the effect of gravity. On the other hand, gyroscopes can only be used to measure linear accelerations with considerable difficulty, and so accelerometer and gyroscope technologies complement one another well (**Figure 4**). Indeed, the combination of a three-axis accelerometer (three linear degrees of freedom) with a three-axis gyroscope (three rotational degrees of freedom) to make a so-called 'six-axis' motion sensor is the ideal solution for precise measurement of all the possible movements of a system.

Microelectromechanical systems (MEMS)

MEMS technology is the key to future growth in the sensor industry. Manufacturing technology for MEMS ICs is allowing devices to be made smaller, more efficient and cheaper. They can be assembled into products using conventional manufacturing processes and so can easily be used in automation, robotics and consumer equipment. MEMS devices employ materials and manufacturing processes used in the semiconductor industry and so can take advantage both of the great depth of expertise in that sector and of the many existing manufacturing plants.



Figure 2. Thanks to the Coriolis force a spinning gyroscope can easily be balanced on the point of a needle.



Figure 3. The artificial horizon in an aircraft cockpit contains a gyroscope mounted on gimbals. The gyroscope wheel is electrically or pneumatically driven.

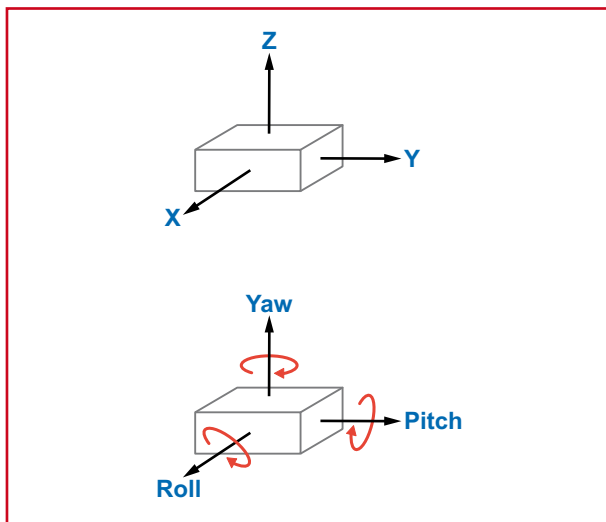

Figure 4. A three-axis accelerometer (above) measures accelerations along the three spatial axes. A three-axis gyroscope measures rotations about the three principal axes.

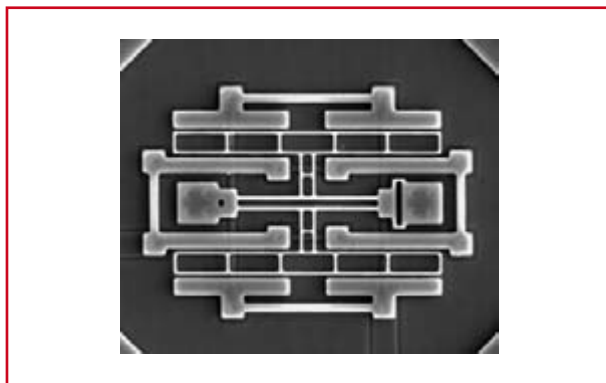

Figure 5. A MEMS 'tuning fork' oscillator.

Specialist literature sometimes refers to MEMS as 'MST' (micro systems technology) or often simply as 'micro machines'.

Although there is no precise definition of what constitutes a MEMS device, it will typically have features on the scale of a few micrometres to a one millimetre. Below that and we enter the field of 'nanotechnology', with geometries typically at least ten times smaller than those of MEMS devices.

Mechanical and electromechanical devices operating at this scale are subject to rather different physical ef-

fects from machines on a more human scale. In particular, as devices are miniaturised the ratio between the surface area of an object and its volume changes markedly: the volume of an object varies as the cube of its linear scale, whereas its surface area varies only as the square of the scale. Surface effects thus tend to dominate volume effects: for example, electrostatic forces and surface tension tend to be significant, whereas moments of inertia and thermal capacities become (relatively speaking) negligible. This need not be a disadvantage; in fact, these effects can be turned to the advantage of a clever designer. **Figure 5** shows an example of a tuning fork oscillator, where the oscillating mass (the part that looks like a ladder) is made to resonate using only electrostatic forces. The oscillator, which runs at around 1 MHz, was designed at Sandia National Laboratory [1]. As structures become smaller and smaller higher frequencies will become possible, and in the medium term MEMS oscillators may start to replace quartz crystals.

The potential for ultra-small machines and systems was recognised long before they became practically feasible. As Richard P Feynman famously wrote in 1959, 'there's plenty of room at the bottom' [2], [3].

Many micromachines can now be made using tools and processes adapted from the semiconductor industry, such as wet etching, dry etching or electrical discharge machining to name just a few. These suffice to manufacture the most popular structures, such as the linear acceleration sensor shown in **Figure 6**. When the device is subject to an acceleration the distance between the interdigitated structures changes, which is detected as a change in capacitance between them.

MEMS gyroscopes

When we try to make an integrated gyroscope using the ordinary techniques used for semiconductor or MEMS manufacture we quickly run into the problem that it is very difficult to make an object that can turn freely. In the literature we see spectacular images of ultra-small toothed wheels and drives (**Figure 7**) but the processes used to make these devices are not appropriate for a ten dollar sensor. The solution is to replace the traditional gyroscope mechanism, which depends on the Coriolis force, by oscillating mechanical elements. These so-called vibratory rate gyroscopes measure the change in the oscillation of a vibrating element caused by a rotation, again using a capacitive technique. Practically all MEMS gyroscopes made today, whether they use the tuning fork design or the vibrating ring design, employ this principle.

Vibrating ring

Figure 8 shows an etched-out ring that is attached to the central hub by eight angled springs. The ring cannot rotate freely, but can be made to vibrate by the application of electric fields via the electrodes. The ring is made to resonate, typically at a frequency of 10 kHz to 20 kHz.

Figure 9 shows, in simplified form, the nature of the vibration at rest (left) and under the effect of an applied rotation (right). The Coriolis force [4] which is produced acts so as to change the axis of the vibration.

The change to the axis of vibration can be measured

accurately using integrated analogue electronics, and very sensitive gyroscopes can be built using this principle. Typical sensors of this type, such as the InvenSense IDG300, have a measurement range of ± 500 degrees per second ($^{\circ}/s$) and a sensitivity of $2 \text{ mV}/^{\circ}/s$. This makes them suitable for robotics applications as well as for a GPS backup system when the satellites are not in view.

Commercial sensors

Manufacturers such as InvenSense [5] are exploiting the possibilities opened up by micromechanical systems with innovative products that create new markets. The current IC platform is based on a whole range of technological innovations in MEMS structure design, in mixed-signal ASIC production processes, and in wafer-level packaging. These developments have led to the world's smallest two-axis gyroscope (**Figure 10**), on a silicon die measuring just 3.5 mm by 3.5 mm by 1.0 mm.

In contrast to resonating rate sensor designs, the InvenSense gyroscopes do not need a hermetically-sealed enclosure to maintain the required operating pressure and provide protection from moisture and dust. The integration of all components, including drive, measurement and signal processing functions, at the wafer level (**Figure 11**) automatically brings the benefits of reduced stray capacitance and inductance. The approach also minimises the number of external components required in the application circuit, helping to reduce cost and physical size. The outputs of the devices are voltages varying up to approximately 1000 mV on either side of a reference level for easy interfacing to other devices in the system.

Cameras and GPS

The availability of low-cost motion and acceleration sensors opens up a wide range of interesting applications. One example is image stabilisation in digital cameras (including the now ubiquitous camera phones). Gyroscopes can measure the inevitable shake of a handheld camera (**Figure 12**) and deliver the necessary data to the image processing DSP device to compensate for the movement. InvenSense calls this technology 'BlurFree' (**Figure 13**) and claims that it can produce clear, pin-sharp images. InvenSense provides image processing software along with their sensor, achieving results that would otherwise require expensive optical stabilisation techniques.

Another important application for micromachined gyroscopes is the enhancement of GPS-based navigation systems with dead reckoning. When the signal from the satellites cannot be received the sensors accurately measure the motion of the unit and thereby update its position. This can be sufficiently accurate to obtain reliable navigation information over moderate distances. The technique is particularly applicable to pedestrian navigation: satellite reception is practically impossible in urban canyons, shopping malls and airports. Future high-end mobile phones will have this feature, allowing the development of more precise location-based services such as finding a local restaurant and assisting with emergency calls.

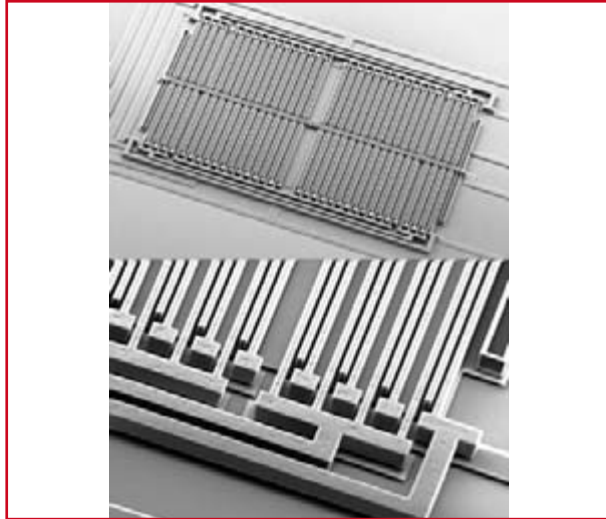

Figure 6.
A linear acceleration sensor.



Figure 7.
With a little work it is possible to construct working drives using MEMS technology.

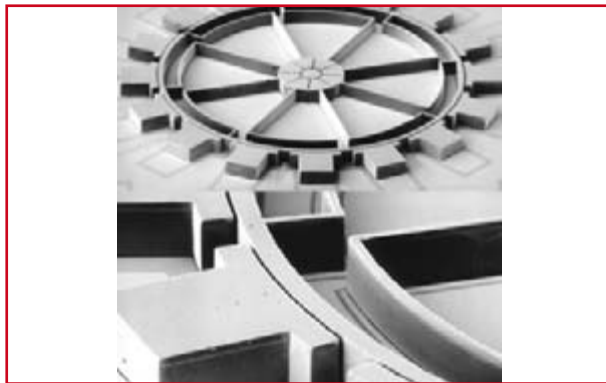

Figure 8.
A ring held in place by springs forms the reference mass for a micromechanical gyroscope.

Body tracking and cybermouse

A further application for motion sensing technology is in game consoles and handheld devices that can recognise gestures and hand movements, taking human-computer interfaces to a new level. There will be a new generation of more realistic video games as well as opportunities to use three-dimensional pointing devices in all kinds of virtual reality applications in the fields of architecture and construction. Body tracking systems, also called body motion capture systems, are used to capture and analyse the movements of athletes and actors. To-

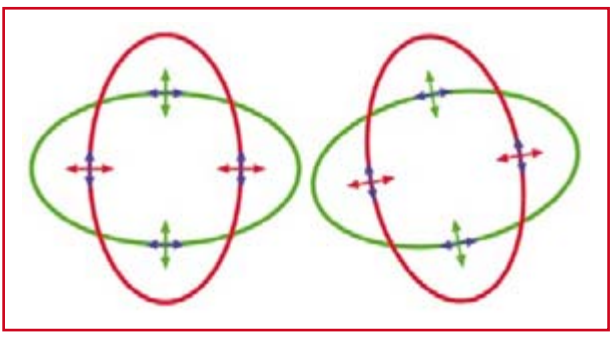

Figure 9. The axis of oscillation of a vibrating system changes when an external angular acceleration is applied.



Figure 10. The IDG1000 two-axis gyroscope measures 6 mm by 6 mm.

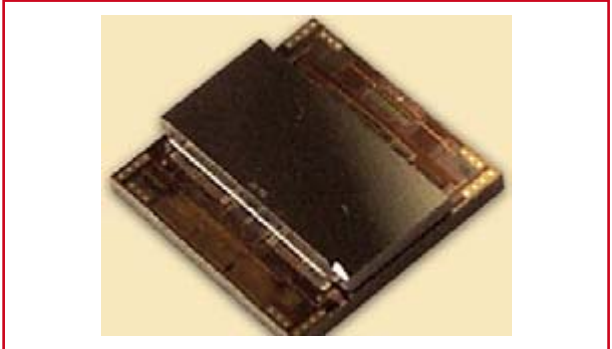

Figure 11. The MEMS gyroscope and peripheral electronics are assembled in a stacked arrangement.



Figure 12. Camera shake, actual and as measured with a gyroscope.

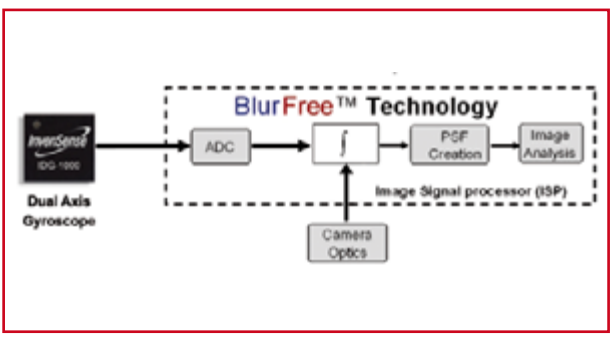

Figure 13. Camera shake can be measured using a two-axis gyroscope and the picture corrected.

day these are based on complicated optical systems but could benefit considerably from the use of gyroscopes: capturing three-dimensional movements and accelerations from multi-axis sensors is much more accurate and simpler than analysing video footage.

(070640)

[1] Sandia National Laboratory: <http://www.sandia.gov/about/index.html>
 [2] 'There's Plenty of Room at the Bottom', http://media.wiley.com/product_data/excerpt/53/07803108/0780310853.pdf
 [3] Wikipedia on Feynman: http://en.wikipedia.org/wiki/Richard_Feynman
 [4] http://en.wikipedia.org/wiki/Coriolis_effect
 [5] <http://www.invensense.com>

About the author

Stefan Tauschek studied electronic engineering, specialising in communications, at the Munich University of Applied Sciences. After graduating he worked for several years developing multimedia components, video processing and streaming media technologies.



He is now a technology consultant for Scantec AG, supporting industrial customers in projects involving networking, telecommunications and automation. He regularly publishes articles on new advanced semiconductor technologies.

E-Mail: stefan.tauschek@scantec.de



Figure 14. Measuring body movements and transferring them into the virtual world is essential to the creation of convincing animations in films and games.

USB Connected High Speed PC Oscilloscopes

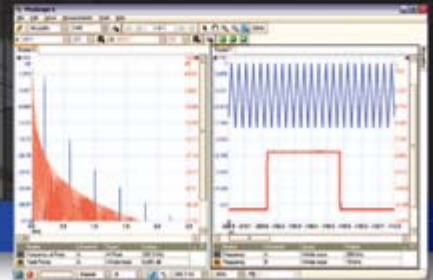
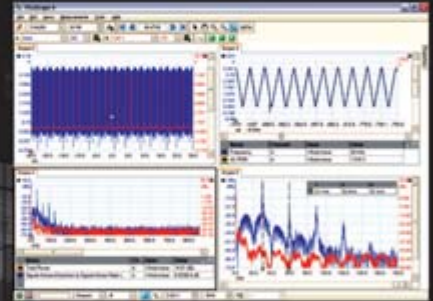
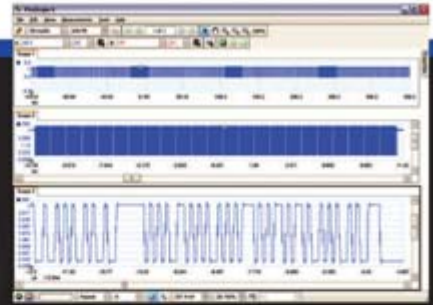

5000 SERIES

PicoScope 5000 Series The No Compromise PC Oscilloscopes

With class-leading bandwidth, sampling rate, memory depth and an array of advanced high-end features, the PicoScope 5000 PC Oscilloscopes give you the features and performance you need without any compromise.

250 MHz bandwidth
1 GS/s real-time sample rate
128 megasample record length

Advanced Triggers

In addition to the standard triggers the PicoScope 5000 series comes as standard with pulse width, window, dropout, delay, and logic level triggering.

250 MHz Spectrum Analyser
High-speed USB 2.0 Connection
Automatic Measurements

Arbitrary Waveform Generator

Define your own waveforms or select from 8 predefined signals with the 12 bit, 125 MS/s arbitrary waveform generator.

Waveform Playback Tool

PicoScope software now allows you to go back, review, and analyse up to 1000 captures within its waveform playback tool.

3000 SERIES

The PicoScope 3000 Series of oscilloscopes from Pico Technology includes general purpose and high resolution models: With 12 bit resolution and 1% accuracy, the 10MHz PicoScope 3424 is able to detect changes as small as 0.024% (244ppm) – making it the ideal 4-channel oscilloscope for analog design and analysis. The higher speed 8 bit models in the PicoScope 3000 series feature sampling rates up to 200MS/s and up to 1 MS/s record lengths for general purpose and portable applications.



2000 SERIES

The PicoScope 2000 series oscilloscopes offer single and dual channel units that offer highly portable/low cost solutions to general purpose testing. The award winning 25MHz handheld PicoScope 2105 fits comfortably into the palm of your hand yet still includes the powerful features found in larger oscilloscopes.



pico
Technology

VISIT www.picotech.com/scope441

to check out our full line of PC-based instruments or call **01480 396 395** for information and a product catalogue

E-blocks DCF Clock

Ported onto Elektor 'PICee' and supporting three time zones

Albert van Bemmelen

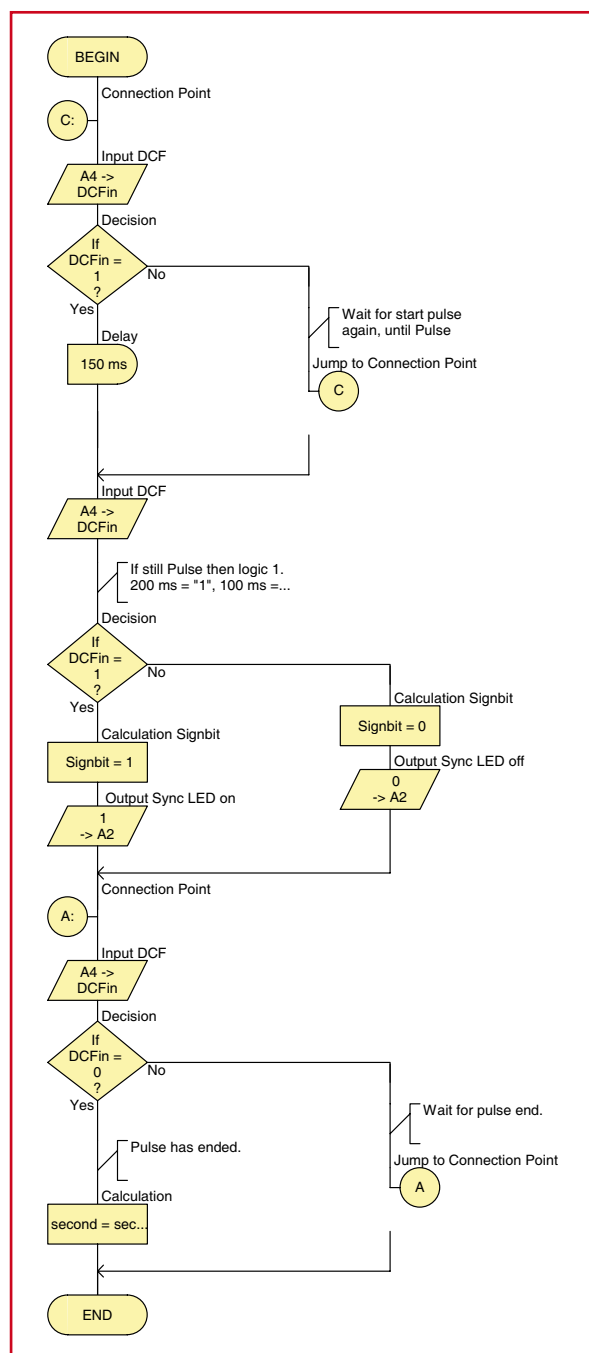

Figure 1. Macro 2 plays a major role in the software.

Here's how the author used Flowcode to develop PIC software for a DCF-controlled clock suitable for the CET, CET-1 and CET+1 time zones. Dispelling the myth that Flowcode has no use outside the E-blocks environment, the end result was cheerfully ported to the famous Elektor 2002 'PICee' development board.

Having successfully completed a number of 'lesser' projects using Flowcode, I decided to try a much more ambitious project: a DCF Atomic Clock Time and Date information Display, which also involved reading and processing pulses in a very exact manner.

Although several assembler programs seem to exist, none of my Flowcode-generated PIC examples ever worked on my own PIC based boards. Even the Elektor PICee board [1] with the Conrad Electronics DCF module never worked as a DCF clock. The same DCF module is now used with this project.

I also wondered if Flowcode 3.0 could help me again in this attempt to make this PIC software myself. As it turned out, the simulator helped by producing and debugging a perfectly working DCF atomic clock receiver program in no time (pun intended). A fully functioning Flowcode program is described (and supplied as a free download) as convincing proof of my attempts.

Research it first!

The first thing I did before making my first Flowcode program was examining the PIC input port schematic, because that is the only way the signals of the outside world get inside the micro. When used as an input port, all ports RA0 through RA4 (plus RA5 when a PIC16F88 is used) and RB0 through RB7 are normally pulled down to ground (logic 0) by a 4k7 resistor. When a switch on a port line is pressed, it will connect through via a 390-Ω resistor to the positive (+5 V) supply voltage. This then represents a logic 1. The only thing we need to know in addition is what signal we are going to connect to the selected port — 'true' or 'inverted' logic. Also, when using the inputs as digital entry points we need a transistor to act as a switch driven by the logic 1 or logic 0 signal applied to its base. Here, that signal comes from the DCF clock module. Alternatively you can press a switch yourself at the right moment and keep it depressed for the right amount of time (as in the Flowcode PC DCF simulator). Level conversion may be required in front of the PIC inputs, and of course we need to make sure that the frequency of the timecode sig-

nal can be detected by the ports used. On the PIC16F88 device, the RA port lines can also be used as analogue inputs using an internal analogue/digital converter. Assuming a swing of 5 V the resolution is 5/1024 (2^{10}) or about 4.9 mV.

Flowcode has an essential advantage in allowing software to be easily ported to another PIC type or another clock frequency afterwards. Here, a PIC type 16F88 was first used with the Multiprogrammer board running at 19.6608 MHz, but the PIC device and clock frequency can easily be changed to suit your requirements. The lowest crystal frequency tested with this project is 6.144 MHz.

How it works

To be able to follow the discussion below, you should have the Flowcode program found in download # 075094-11.zip on your screen or on paper.

After receiving a no-pulse interval of about 1000 ms (20×50 ms), during the 60th second of every received DCF minute the LCD will synchronise with the correct time, day, month, year readout. The value displayed on the right of the display gives the currently received bit value of the DCF information during every second. (- for a 0; ^ for a 1). Every minute, the Flowcode-programmed PIC receives 59 of these bits (the 60th second is represented by a 'pause') representing BCD coded values.

In order to keep the Flowcode software simple and easy to debug, and also to keep the main program uncluttered, at least three separate program parts are used. Macro 1, called *DCF_Synchronize*, takes care of the synchronisation in the 60th second. A second Macro called *Getbit* receives a new bit value every second and converts any 100-ms pulse length into a logic 0, and any 200-ms pulse length into a logic 1. Macro 2, shown in **Figure 1**, also waits until the pulses are ended before the program continues with, for instance increasing the Seconds counter, or adjusting its value when value '61' is reached. And last but not least, the *DCF_Array[]* will also be filled here with the measured bit value of that last second. After exactly 59 received seconds, the time/date is distilled from the discrete bit values in order to put the correct information on the clock readout.

It will be obvious that it's essential for this second macro to function flawlessly, since even if *Synchro* starts pro-

erly, *Getbit* still tests for a correct 100-ms or 200-ms pulse every second. Every wrong bit will automatically mean incorrect displayed data, especially when 'seconds' run out of sync. Using the software approach described, only AM disturbance at the 77.5-kHz receiving frequency can cause real problems.

A third macro fills the LCD in such a way that all data from the 59-second 'time telegram' is displayed correctly. In the Main program, finally, you'll find the BCD conversion math algorithms that convert every bit value correctly for every item and calculate it to the associated decimal values. In the first Flowcode version I wrote, a parity check was missing — no real disaster because it was immediately obvious when any received data was wrong. Moreover, after synchronizing again to DCF it was usually okay the next minute (*à-la-minute!*). A simple even-parity bit check is implemented in the latest version of the software.

Three time zones

I had no trouble making a working Flowcode DCF CET clock. But adding CET-1 and CET+1 modes was a whole different matter. This is because the German DCF 77.5 kHz transmission only contains CET (= GMT + 1 hour) information while it can be picked up (though not constantly) as far as the Polish-Russian border and the Irish West coast. A discussion of the software adaptations necessary to allow for three time zones is found in the **supplementary document** available free of charge from the Elektor website.

The setup for E-blocks

When using the E-blocks Multiprogrammer board, A0 will be the DCF signal input port. An A0 port LED will

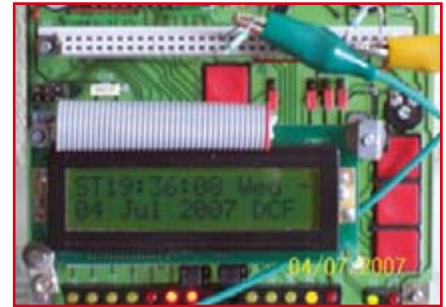

Figure 2. Clock, date and DCF reception readout (on PICee board).

come on with active-High DCF signal. Similarly, an A2 port LED will light up when *Signbit* is logic High. Take care! Neither ports A7 nor A1 seemed to function well as a DCF sync error LED indicator output. Port A4 nevertheless functions splendidly for this function, in real life and in PC simulation mode. The A4 LED automatically goes out after about 60 seconds when the DCF time signal is successfully captured.

The readout on the 16x2 LC display looks as follows (**Figure 2**):

```
ST 23:22:12 Thu ^
26 Apr 2007 .DCF
```

On the readout, 'WT' is shown for winter time; '.DCF' when synchronized, 'ERR' if there is poor or no DCF reception.

The day of the week, **Sun, Mon, Tue ... Sat** is in BCD code values 7, 1, 2...6. In case of parity (receiving-) errors the next lines will be displayed:

Hour WRONG or **Minute WRONG** on line 1; **D/M/Y WRONG + ERR** on line 2 (or a combination of these).

Flowcode did it

This project like no other revealed the power of Flowcode Professional — the only problem as I see it could be with

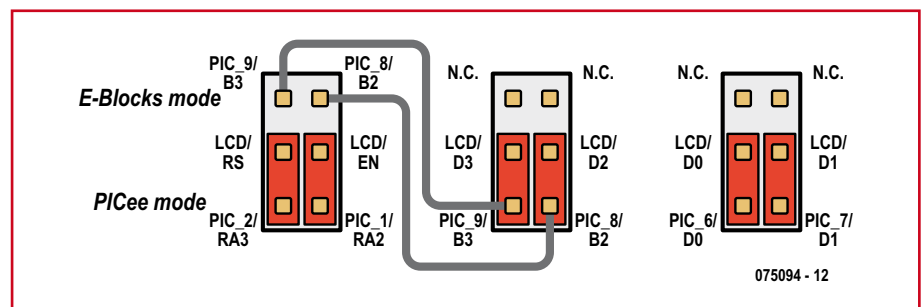

Figure 3. To make the Elektor February 2002 PICee Development Board E-blocks compatible, datalines D0-D3 to the LCD have to be broken. This is effectively done by setting the centre and right-hand jumper blocks to the 'up' position. The 'low' position allows you to revert to the original PICee mode.

pulses that are too fast to be detected by the input ports of a PIC programmed using Flowcode!

Over to the PICee board – hardware matters

The later version is an adaptation for the Elektor PICee board. Here, port RA4 will be the DCF input after a small hardware modification of the PICee LCD. Port A5 is now assigned to the DCF Error LED, and port A2 still can be used as the *Signbit* value indicator. The PICee setup has been successfully tested at a frequency of 6.144 MHz.

The PICee board be modified to accept the Flowcode-programmed PIC processor. Why, how? Normally, programmed PICs are not exchangeable between the E-blocks Multiprogrammer and the Elektor PICee dev board, although they're both quite ordinary PIC programmers! The crux: The PICee board sends out its LCD data 8-bits wide. By contrast, the E-blocks Multiprogrammer board employs 4-bits wide LCD communications.

Now Flowcode 3.0 is unable to address its LCD using Port-A and Port-B bits simultaneously — it employs Port B exclusively. The PICee board uses both port A and port B to address the LCD. The two systems can be 'married' by placing three double-pole toggle switches arranged as 6 jumpers above and under the PICee LCD. The drawing in **Figure 3** illustrates the method. Also disconnect the LCD printed copper connections in accordance with the drawing. It may be very handy when all new jumpers are fitted in parallel with the LCD (from East to West) so they will be easily recognised as they differ from the direction of original jumpers (North to South).

There's plenty of space on the PICee board, see **Figure 4**. Fourteen light-duty wires are installed in such a way that the jumpers for the E-blocks compatible position all point in the same direction (to the left, assuming the LCD on the PICee board is at the bottom of the card pointing downwards; with the component-side showing). The 'standard PICee' position is: to the right. Note that not all pins are wire-connected pins but they're still needed as jumper holders and serve logistic simplicity. Disconnect the following copper connections to the PIC socket of the PICee board:

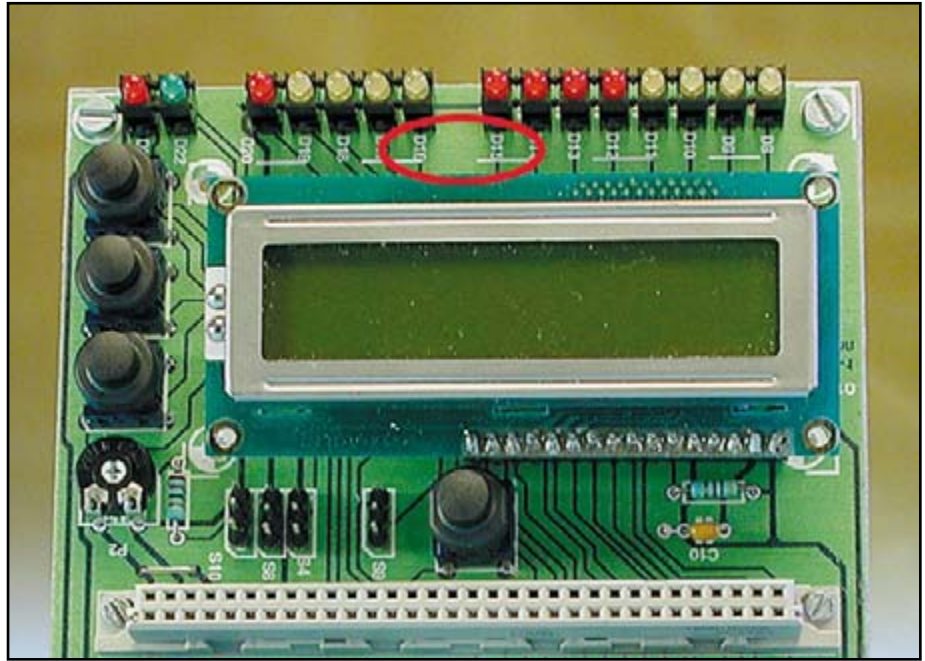

Figure 4. This area between the LCD and the LED array at the edge of the 2002 PICee board is suitable for installing the additional jumper blocks to select between E-blocks and PICee mode.

Pins 1 (Pic_RA2) and 2 (Pic_RA3)
 Pins 8 (Pic_RB2) and 9 (Pic_RB3). The four broken connections are now the P(ole)-contact wires of the first two 2x3 'changeover' jumpers.

Flowcode adaptations for PICee

In Flowcode, if a PIC program using a clock frequency of 19.66 MHz is converted to, for instance, about 4 MHz without changing the Delay blocks, then Flowcode will very likely propose a change. Without this change in the timing of the Delay blocks, the DCF clock won't work as expected! The DCF Flowcode clock works perfectly with any clock between 19.6608 MHz and 6.144 MHz, but not without changes at around 4 MHz.

The Flowcode software adjustments relate to the LCD configuration window: all Port B settings must be changed as follows

- Data1 Port B must change to bit 4;
- Data2 Port B must change to bit 5;
- Data3 Port B must change to bit 6;
- Data4 Port B must change to bit 7;
- RS Port B must change to bit 3;
- Enable Port B must change to bit 2.

These changes do not affect Flowcode in any way because we just use as many Port bit connections as we did before. These small changes have an important advantage in that we do not

have to rearrange all LCD data lines on the PICee board to adapt to Flowcode and the E-Blocks Multi-programmer settings. Using the jumper blocks you can switch back and forth between 'E-Blocks' and 'PICee' mode — with the power supply switched off, right?

Conclusion and freebies!

Thanks are due to Matrix Multimedia for their fabulous Flowcode Professional version 3.0 software. It is one of the fastest, reliable, and not to forget highly user-friendly (PIC) microprocessor simulators that helps any enthusiast to create and realise things that he/she never imagined possible (and all in a very short time)!

The Flowcode program for the clock project may be downloaded as file # **075094-11.zip** from the Elektor website. A free, supplementary archive file # **075094-21.zip** contains a Word document in which the author presents the software revision history, the way he implemented three time zones and the design of a DCF Generator, not forgetting photographs and screendumps. Well worth having a look at.

(075094-1)

Reference

- [1] PICee Development System, Elektor Electronics February 2002.

PCB-POOL®

SERVICING YOUR COMPLETE PROTOTYPE NEEDS

1 EUROCARD
(160 x 100 mm)
+ Tooling
+ Photoplots
+ VAT

€49

Price example
Any size and contour possible!

Optional:

- Soldermask
- Fast-turnaround
- Silkscreen
- 4-Layer Multilayer
- 6-Layer Multilayer

DOWNLOAD OUR FREE LAYOUT SOFTWARE!

Freephone  **0800-3898560**

Tel.: +353 (0)61 701170
Fax: +353 (0)61 701165
pcb-pool@beta-layout.com

Over 18,000 Customers

Beta LAYOUT

LEAD FREE

PCAD CAM351 Proter EXCEL oECad GerberGate MIMIC Protel Easy-PC Eagle

Simply send your files and order ONLINE: **PCB-POOL.COM**

audioXpress

TIPS

TWEAKS

PROJECTS

DIY audio at its best!

12 monthly issues for only \$63 US

Subscribe at www.audioXpress.com

PCBs in 24 hours from £30.00

www.PCBTrain.com

Tel: 01635 40347 Newbury Electronics Ltd
Fax: 01635 36143 Faraday Road Newbury Berks RG14 2AD
e-mail: circuits@newbury.com.co.uk www.newburyelectronics.co.uk

Approvals: ISO 9002/UK

№1 Number One Systems

Easy-PC for Windows

The World Beating PCB design software

The new Easy-PC reaches even higher!
The breathtaking new Easy-PC for Windows Version 11 is released. Winning accolades the world over, V11 of the market leading Easy-PC delivers even more remarkable value for money and sets the new benchmark for performance in PCB CAD.

STILL FROM ONLY £247 PLUS VAT

Just try a demonstration copy of Easy-PC and prepare to be amazed...

Easy-PC delivers a simple to understand, fully integrated Schematics & PCB layout in a single application. Design and rules checks at all stages ensure integrity at all times. Professional manufacturing outputs allow you to finish the design process with ease.

Stop press... Stop press... Stop press...
Easy-PC is supported running under Windows Vista

Version 11 features

- Design revision analysis
- Star/Delta points
- Apply layout pattern & groups
- Design calculators
- Electrical rules check (ERC)
- Shape editing panel
- Merge/subtract shape editing
- Track analysis

Plus many more exciting features...

Call for a brochure, prices & CD on +44 (0)1684 773662 or e-mail sales@numberone.com you can also download a demo from **www.NumberOne.com**

Oak Lane, Bredon, Tewkesbury, Glos. GL20 7LR. United Kingdom

25 YEARS 1979 - 2004

Designed for Microsoft® Windows® XP, 2000, ME, 98, Windows NT®

A Radiant Future

Wireless communication technology and security



Frank Leferink

Electronics is the wave of the future. Just about anything you can think of appears to be technically possible. However, there are a few potential difficulties that must be considered first. As the number of wireless connections will doubtless continue to increase, EMC will become an increasingly important factor. What effect do all these electromagnetic fields have on people? Only the future can tell.

Although it may not be immediately apparent, we are fully dependent on technical systems, including electrotechnical systems. In fact, we already can't manage without them. What would we do if all our electrical equipment and electronic circuits stopped working so that we no longer had light or heat, our water and gas supplies failed because the pumps stopped, and even our telephones stopped working? Transport would no longer be possible because the electronic systems of cars and lorries would also stop working. As a result, shops would no longer receive deliveries and their stocks would quickly be sold out – assuming we still had cash on hand to buy them, since paying with a bank card or electronic purse would be impossible. With televisions and radios no longer working and no newspaper in sight, this would lead to major chaos. A dream situation for every terrorist, and a doom scenario for the government.

Disastrous

This is also a doom scenario that must be taken seriously, because a small atmospheric nuclear explosion can generate an enormous electromagnetic field (50 kV/m), which is also called an 'electromagnetic pulse' (EMP). Such a pulse can induce high voltages and currents in all conductive materials. The effect is comparable to a lightning strike at a distance of around 10 metres, but with an EMP the field is effective over an area with a diameter of 3000 km – everywhere and at the same time. The high voltages or currents in practically all connected semiconductor devices would cause short circuits and turn even the most wonderful chips into little pieces of dirty silicon. This effect has been known for decades, and military equipment is designed to resist an EMP – but our civilian infra-

structure is not. Maybe this makes the paranoid behaviour of the Americans with regard to 'terrorist states' a bit easier to understand. European government organisations (Brussels) do not take this threat seriously. For instance, a government official recently said that EMC is not a problem ('EMC' stands for 'electromagnetic compatibility') because the EMC Directive [1] has taken care of everything. Naturally, the EMC Directive is not intended to protect society against 'EM terrorism'. Its objective is to ensure that equipment is designed and built such that it does not interfere with any services and is not susceptible to interference from other equipment. Even then, this does not mean that the directive has cleared up all EMC problems.

Secure?

There are various options for amateur 'terrorists' who want to challenge our sense of security:

- More than fifteen years ago, a group of students made telephone calls all over the world by interfering with the electronics of a telephone in a telephone booth. As an interference source, they used a piezoelectric lighter fitted with a small loop antenna.
- Around the same time, people interfered with the operation of gambling machines, as was reported in various newspaper articles. You can imagine that the casino owners in Las Vegas were in total panic.
- Thieves in St. Petersburg managed to interfere with the operation of the electronic security system of a jewellery shop and steal the entire contents of the shop. We now know that the Russians were much more advanced in creating intentional interference than people in the Western world.
- There are unconfirmed reports that a few banks in London have been 'attacked' using 'intentional electromagnetic interference' (IEMI) weapons.

With increased use of RFID devices, RFID zappers are becoming attractive. Instructions for converting a disposable camera can be found on the Internet, with the high-voltage portion of the flash being used to drive an antenna. This can create a field that is strong enough to damage the circuitry of an RFID chip. As you can imagine, department stores that use these chips everywhere are not fond of this idea. The baggage handling department of Schiphol Airport in The Netherlands, which also uses RFID chips, also regards it as a significant problem.

Trends

The discipline of EMC is often driven by new technologies, and in light of the fact that new technologies are being introduced faster than old ones are being retired, the importance of EMC as a discipline can only increase. For example, there is a limit to how fast signals can travel inside an IC. The speed is determined by the (electromagnetic) parasitic effects of the pins of the IC package. The only way to output the volume of data is to use optical communication methods so ICs can communicate via glass fibres. Intel is working hard on this. By the time this technology becomes

commonplace, we hope that every house will be connected to a national optical fibre network. As optical fibres do not create any electromagnetic fields outside the fibres, does this mean that they will eliminate many interference problems? The answer is yes, but by then we will have many more wireless communication systems, electromagnetically noisy Class D audio amplifiers, plasma screens with fast-edge drive signals, and frequency converters in many moving systems in our everyday environments, such as washing machine motors and ventilation systems. The time-varying supply of electrical energy to ICs in optical communication systems is also a potential source of interference. In addition, signal frequencies are now so high that the wavelengths have decreased to the same order of magnitude as the chip dimensions, with the result that these signals also generate fields and are sensitive to external fields. As a result, EMC will continue to be important for quite a while.



Figure 1. More and more intelligent electronics systems are being used in cars.

Society

Security and safety systems are experiencing major growth in our everyday surroundings, including transportation – just think of tracking & tracing systems, drive-by-wire and brake-by-wire systems, steer-by-wire systems, and so on. Health risks are also continuing to increase, and increased attention is being given to the risks of electromagnetic fields and electrosmog. A change of mentality can be seen here – people are no longer prepared to wait indefinitely. The 'just-in-time society' has become a fact. Home automation is a growth industry. Anything you want can be arranged: a flexible infrastructure, a mixture of data and energy, media comfort, healthcare at home, air quality, and so on. You can be connected anywhere and everywhere, anyplace, any time, to any network on any device, receive the right information, and use secure, low-energy, ubiquitous networks. Several economic trends show a demand for increased functionality in a smaller volume at a lower price. However, technological trends are just as important for those of us with a personal or professional interest in electronics, and probably more interesting. Technological trends usually result from social and economical trends, which create market pull (consumers want new products) instead of market push (technology offers new possibilities). This means that the need for a secure society will (hopefully) lead to reduction of the interference suscep-

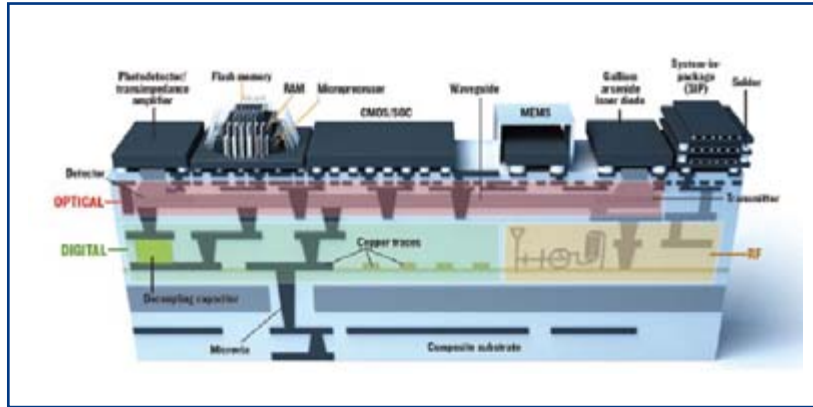

Figure 2. Advanced integration: circuit components embedded in the PCB.

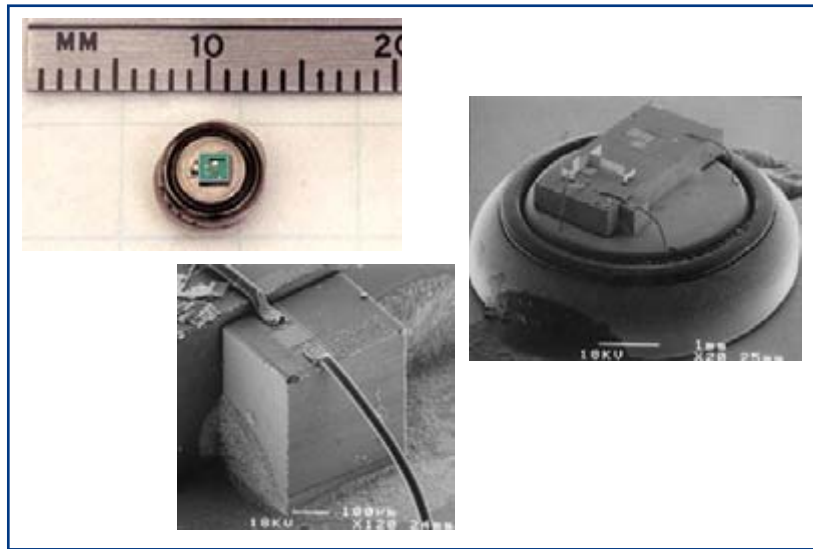

Figure 3. Smart dust: tiny circuits with unprecedented potential.

tibility of many systems, including RFID systems and affordable communication media such as wireless LANs, Bluetooth and so on.

The social desire to reduce air pollution will lead to a sharp increase in the amount of electronics, sensors, controllers and actuators in vehicles. Potentially vulnerable electronic control systems are becoming increasingly common in vehicles, including cars, aircraft and trains. The cost of the electronics in a modern car is already approaching 40% of the total cost. Electronic systems are used for automated vehicle control, radar techniques for detecting objects and obstacles, intelligent weather sensors, onboard wireless networks to reduce the amount of wiring, etc. (Figure 1).

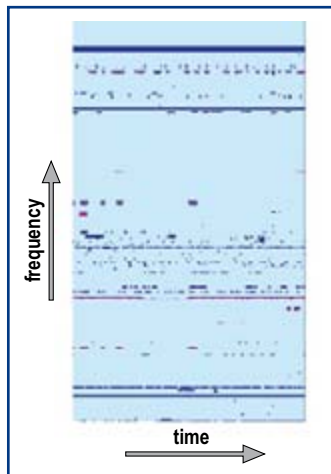

Figure 4. The frequency spectrum is not yet being used efficiently.

Intelligent traffic systems for adaptive vehicle control will form a significant trend. With such systems, a car receives a signal when it enters a village or town and its maximum speed is limited to 50 km/h. Speeds can

also be 'advised' externally in 'green wave' regions and on roads with dense traffic.

Developments

Signal transmission speeds are constantly increasing, although Moore's Law [2] is already limited outside the chip by the IC package. For this reason, several chips can be housed in a single package in what is called a 'system on chip' package.

We also see an increase in mixed-signal chips (analogue and digital circuitry in a single package). This leads to new problems, such as substrate noise and decoupling at the chip level. This technology is already commonplace in high-end applications. Capacitors are already being integrated into the BGA substrate to prevent interference currents from reaching the circuit board.

Future expectations can be seen from the Information Technology Services Request (ITSR) roadmap (Table 1). The developments outlined here are already being used. It can be expected that in system designs in the near future, the printed circuit board will not only provide the interconnections but also contain actual components (see Figure 2). These are called 'embedded components'.

There is also a lot of research on sensors that automatically make contact with each other and spontaneously form networks. This leads to fewer connection dropouts because communication can always proceed via another part of the network. Sensors of this sort can usually measure many different things, such as temperature, wind speed, motion, sound, and electromagnetic fields. They are used in factories, hospitals and the military. However, household use is also quite possible, such as in climate control systems, soft lighting that switches on when dusk falls or you come home, lighting systems that simulate an occupied house while you are on holiday in order to deter thieves, etc. There are lots of possibilities.

With advanced miniaturisation, these sensors (which are actually small circuits) can be made very small – so small that they are sometimes called 'smart dust' (Figure 3). Smart dust can easily be distributed from an aircraft, and it can autonomously create a network consisting of literally thousands of sensors. It is hardly surprising that the military is especially interested in applications of this sort.

	2000	2005	2010	2015
Transistor gate length (nm)	130	80	45	25
On-chip clock frequency (GHz)	1,2	5	15	33
Off-chip frequencies (GHz)	0,7	3	10	29
Equivalent edge steepness (ps)	455	106	32	11
Supply voltage (V)	1,9	1,1	1,0	0,8

As these systems must be inexpensive and will lack good filtering due to financial constraints, many EMC problems will arise. If we aren't careful, a situation in which a passing tram causes the lights in nearby houses to blink like Christmas-tree decorations is not inconceivable.

Crowding banished

You might imagine that the radio spectrum is getting rather crowded with all these wireless systems, but usually they all share only a small portion of the spectrum, such as the 2.45-GHz band. Here you find your microwave oven, Bluetooth signals, and WLAN signals. Experiments with these systems have shown that they can cause a lot of mutual interference. You can easily bring a WLAN to its knees with a simple modification to a microwave oven. However, the crowding in the frequency spectrum is actually not that bad. **Figure 4** shows measured frequency use in the mobile telephone band versus time. You can see that there is a lot of empty space, which means that the frequency space is not being used efficiently. The proper approach is not to assign a specific frequency to each user, but instead a combination of frequency, time and perhaps coding as depicted in **Figure 5**. This technique is called TFMPs multiplexing (Time-Frequency Modulation Polarization Space). It is already being used on ships, where a large number of systems must work together in a small space with limited bandwidth.

'Smart antennas' (which are actually ordinary antenna arrays) can be used to beam signals in the direction where you want to send the energy. If the beam is controlled on request of the users, this called 'adaptive beamforming'. With this technique, the number of users that the antenna can serve can be increased by a factor of more than 2.5, or the same number of users can be served with fewer antennas. This technique is already being used in California.

Good or bad?

This brings us to the final point to be examined in this article: exposure of people to electromagnetic fields. One of the problems with wireless communication is the 'visibility' (including electronic visibility) of the antennas. One way to reduce the amount of exposure to radiation would be to use adaptive antenna arrays. If the antenna arrays were also integrated into building walls to make them relatively inconspicuous, it is quite probable that fewer people would suffer from headaches and other complaints. Incidentally, electromagnetic fields are more often useful than unhealthy. For example, they are used by physiotherapists to warm muscles, they are used to render cancer cells harmless

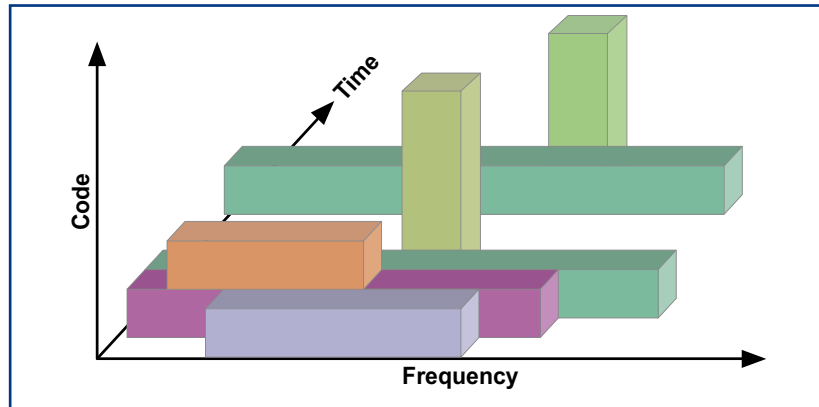

Figure 5. A better approach is to use TFMPs multiplexing, which involves assigning a combination of frequency and time to each user.

inside the body, and by now a lot of research has been carried out on the effects of currents and fields on the nervous system. The same results can be achieved with these fields as with chemical agents, and sometimes even better. It is surely clear that progress cannot be stopped, and as with so many things, every advantage has its disadvantage. We must all constantly keep a good eye on where we're heading in the future.

(060336-1)

Web Links

- [1] www.euronorm.net
- [2] en.wikipedia.org/wiki/Moore's_law

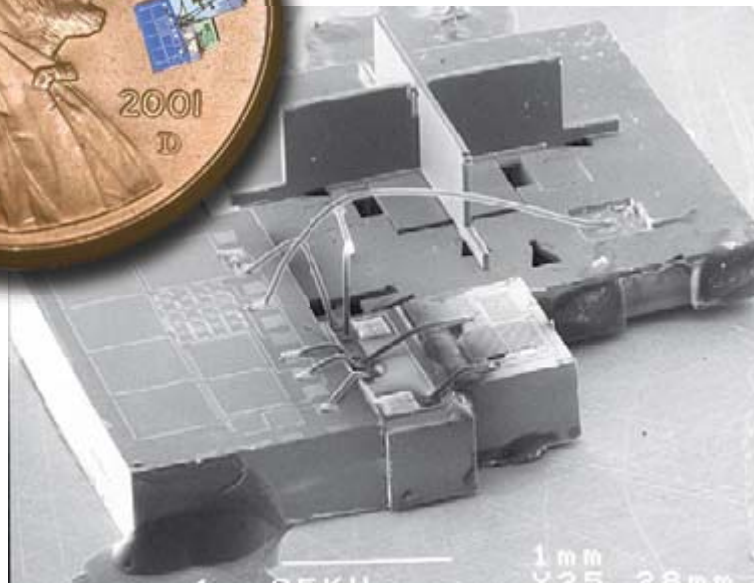

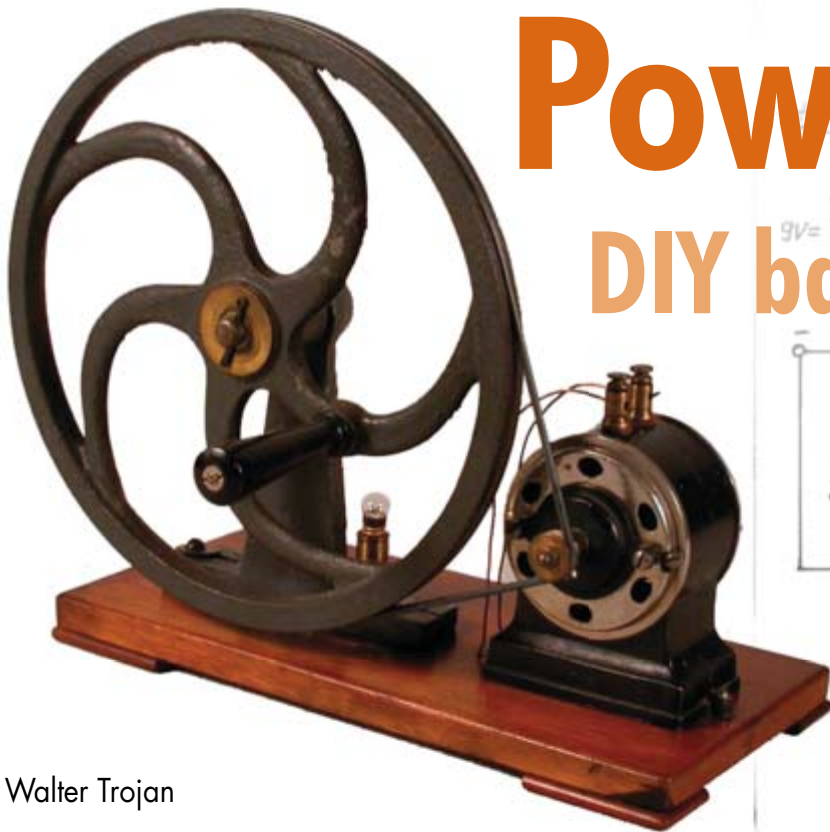

Walter Trojan

Power on Tap

DIY backup power system

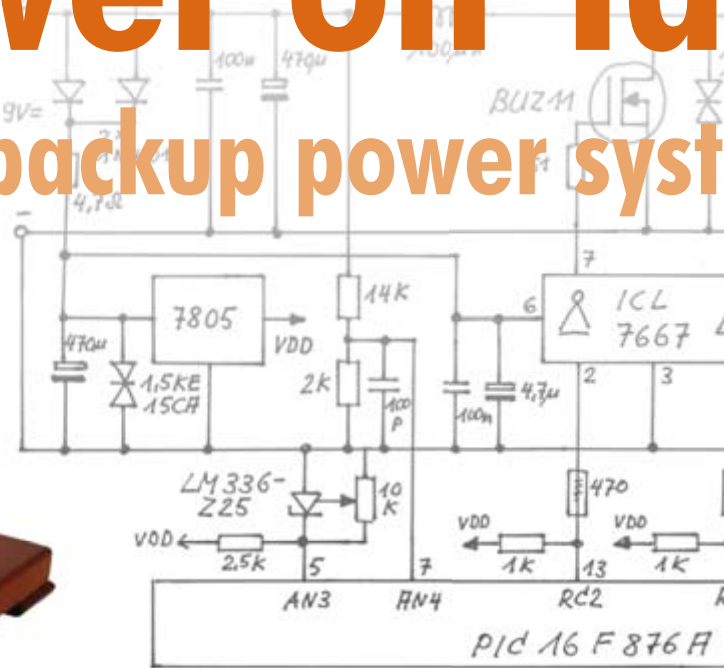

Natural disasters and freak weather conditions that cause electrical power dropouts, even if only for a few hours, are being reported in the news increasingly often in our part of the world. Wouldn't it be a nice if under these conditions your central heating system kept on working, you could still use the radio or your computer to obtain information or continue working, and the contents of your freezer would stay frozen?

In this project, the author has used readily available components and a bit of original design to create a backup power system with an output capacity of 300 to 600 VA. Thanks to its portability, you can also use it outdoors to provide mood lighting for a barbecue party or power a sound system for several hours. And in a hard winter, the battery can also come in handy as a booster for starting your car.

An alternative to this system would be a high-capacity, petrol- or diesel-powered generator set. However, with such systems you have to keep a store of hazardous fuel, and they produce a considerable amount of noise and noxious exhaust gasses.

Condition trainer

The energy source of the backup power system is a conventional car battery. Here it can be advantageous to use the same type as is used in your car. The author used a 12-V lead-acid battery

with a capacity of 74 Ah, which cost a bit more than £ 70 (about € 100).

The output voltage at AC mains potential is provided by a voltage converter (12 VDC to 220 VAC) with the desired output capacity (300 to 600 VA). Depending on the loads to be connected to the system, you can use a converter with a trapezoidal output waveform or one with sinusoidal output. Trapezoidal-output converters with a capacity 300 VA are available from mail-order electronics suppliers for around £ 35 (about € 50). Sinusoidal-output converters are twice as expensive.

Just add an AC adapter to charge the battery, and you're all set – or so you might think. Unfortunately, this is not the case. Although lead-acid batteries appear robust, they are actually quite delicate. Despite this, you want to have a power source that is always ready to deliver its full capacity if necessary. To ensure this, the author has developed a 'condition trainer' for the bat-

ttery that provides the following functions:

- Charging the battery and maintaining it at full charge using an IU_oU_p charging curve (see **Figure 1**)
- Constantly activating the battery to maintain its capacity
- Displaying battery data and health status

All this is controlled by a PIC microcontroller, which in combination with a boost converter also generates the current for charging the battery and maintaining its charge (see **Figure 2**). The structure of the firmware is shown in **Figure 3**.

Good care prolongs life

Lead-acid batteries are rather delicate, so you have to take good care of them if you want them to live to a ripe old age. The conventional car battery used for this project has a rated capacity of 74 Ah, which means it can supply a current of 7.4 A for 10 hours. Car bat-

pe

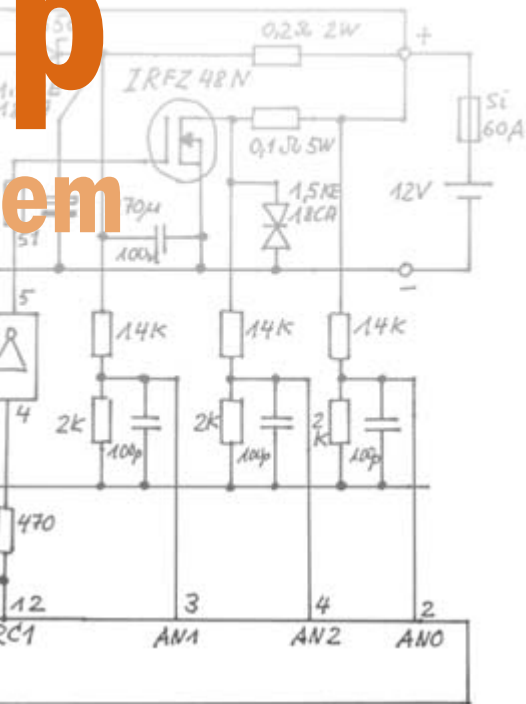

teries can supply considerably higher currents for short periods, but this comes at the price of reduced capacity. If you want to draw 300 VA from the system, the battery has to supply nearly 30 A to the voltage converter if the conversion efficiency is 90%. However, this should be enough for a good two hours of emergency power. For maximum battery life, no more than 70% of the rated capacity should be drawn from the battery (discharge voltage approximately 11.3 V). The battery should never be deep-discharged to a voltage less than 10.5 V, since this will cause a permanent reduction in capacity and may even destroy the battery. Lead-acid batteries also require careful attention at the other end of the scale (fully charged voltage). Gas generation, which starts at 14.4 V, should be avoided during charging due to the associated explosion hazard. Another hazard is sulphating, which occurs during discharge and involves formation of a layer of smooth lead sulphate crystals on the rough surface of the lead plates, which reduces the battery capacity. However, these deposits can be blasted loose by brief, intense current pulses (around 100 A). These features of lead-acid batteries are taken into account by the selected charging curve. It is based on the IU_0U_p principle, which means that charging starts at a constant current (in this

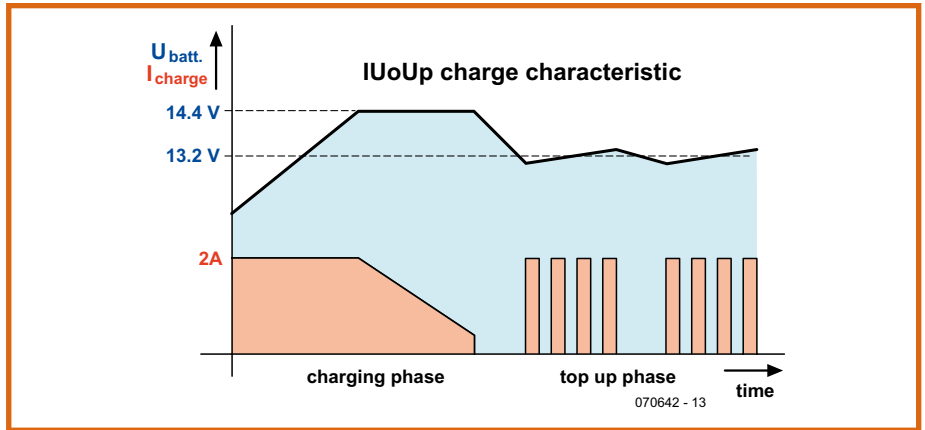

Figure 1. IU_0U_p charge curve.

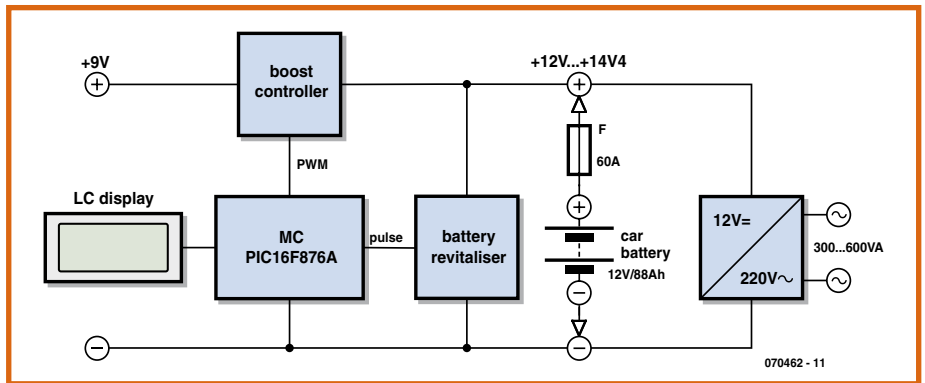

Figure 2. Block diagram of the circuit.

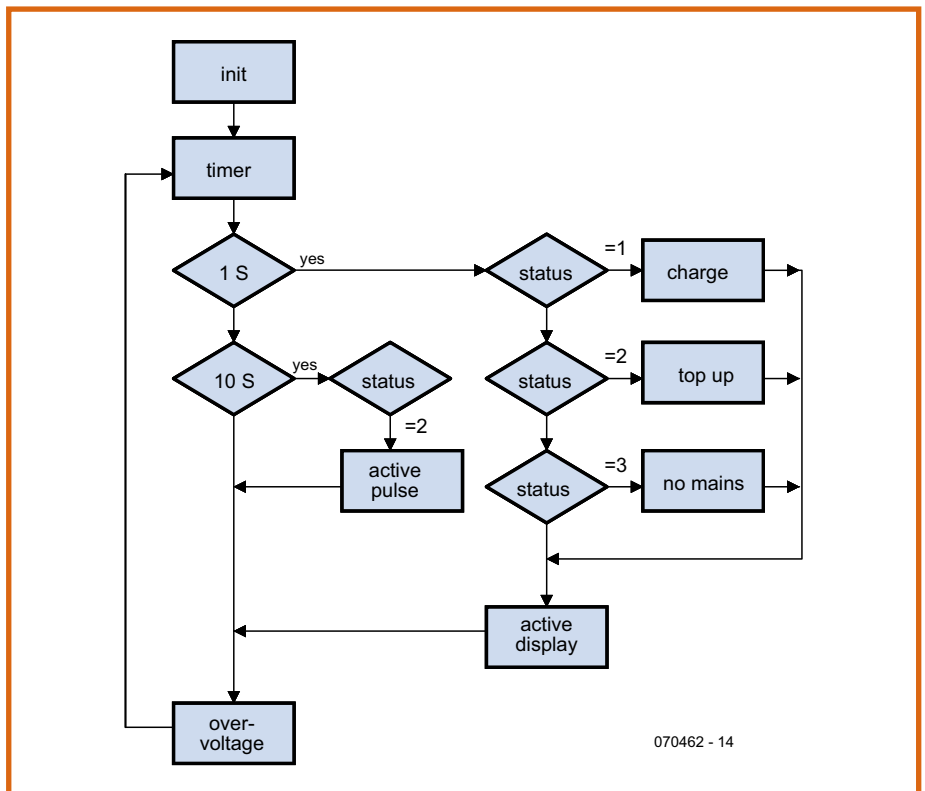

Figure 3. The program structure is abundantly clear.

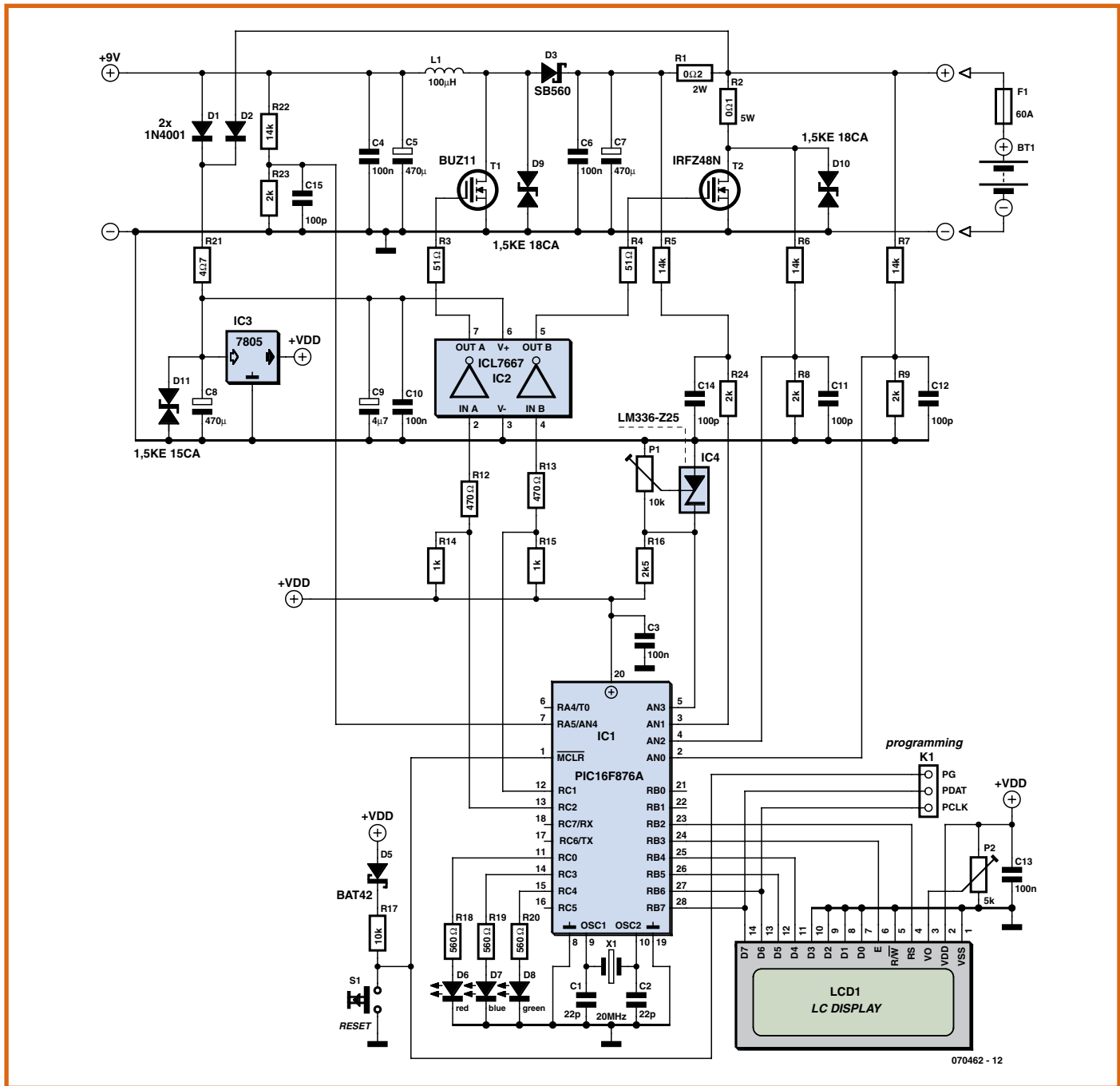

Figure 4. The number of components has been kept to an absolute minimum. Most of the tasks are handled by the microcontroller.

case 2 A). When the battery voltage reaches 14.4 V, the circuit switches to constant-voltage mode (U_c) and charging continues with a steadily decreasing current. When the charging current drops to a lower threshold of 0.2 A, the circuit switches to float charge mode. In this mode, a voltage of 13.2 V (U_p) is maintained by a series of 2-A pulses with a pulse width of 50 ms. An activation function in the circuit combats sulphating by forcing intense discharge pulses of around 100 A every 10 seconds with a pulse width

of 200 μ s. These short current pulses do not cause any significant discharging of the battery because they correspond to an effective discharge current of 2 mA.

Complexity

The author's objective was to implement the above-mentioned functions with the least possible amount of hardware. The circuit is built around a 16F876A PIC microcontroller (see Figure 4), which is readily available and

incorporates the necessary subsystems such as an A/D converter, PWM output, and a comparator. The other active components are a MOSFET driver IC (ICL7667) and two power FETs (BUZ11 and IRFZ48N).

The basic circuit and the display module are quite ordinary. The microcontroller is clocked at 20 MHz to obtain the high time resolution required for the boost converter PWM drive signals. The operating status is displayed on a LCD module with 2 lines of 16 characters. The LCD module is driven via

port B in 4-bit mode. It displays the following parameters:

- Charge: battery voltage and charging current
- Float: battery voltage, activation pulse current, and relative capacity in percent
- AC dropout: battery voltage

In addition, three LEDs driven by port C indicate the activities of the condition trainer (see table).

Measure first, then adjust

The ADC in the PIC microcontroller is used to measure the values needed to control recharging and float charging, which are then evaluated by the firmware. A stable external reference voltage derived from Zener reference LM336-Z25 (IC4) is applied to port AN3 to ensure high accuracy. With the voltage set to 2.5575 V using trimpot P1, the ADC resolution is 2.5 mV with 10-bit conversion.

Voltage dividers with a ratio of 8:1 are connected to inputs AN0, AN1, AN2 and AN4 to extend their measuring ranges to 20.46 V with a resolution of 20 mV, which is adequate here.

The following quantities are measured via the above-mentioned inputs:

AN0: battery voltage, which is lower than the voltage at AN1 by the voltage drop across R1.

AN1: boost converter output voltage.

The charging current is derived from the difference between AN1 and AN0.

AN2: low voltage during the activation pulse. The pulse current is derived from the difference between AN0 and AN2.

AN4: input voltage from the AC adapter.

High-efficiency charging

The charging and float currents for the battery are provided by a boost converter that operates from the 9 VDC supply voltage provided by the AC adapter. It consists of inductor L1 (100 µH), FET switch T1 (BUZ11), Schottky diode D3 (SB560), and storage capacitor C4. Capacitor C5 at the input decouples switching noise on the supply voltage, while C6 and C7 reduce switching transients. The boost converter is driven via port RC2 and half of the driver IC.

To enable the most precise possible adjustment of the output voltage, the PWM generator is operated with the maximum possible resolution of 10 bits, which allows a PWM rate of

Status LEDs			
	Red	Blue	Green
Charge	On	On	Off
Float	On	Off (on during charge pulse)	On (off during activator pulse)
AC dropout	Off	Off	On

19.53 kHz to be achieved with a 20-MHz clock frequency. Although boost converters usually operate at around 50 kHz, this does not cause any significant decrease in efficiency.

With an input voltage of 9 V, the boost converter provides an adjustable output voltage with a maximum value of 15 V and a charging current capacity of 2 A. With a measured efficiency of 88%, the output capacity of the AC adapter used here (36 W) is almost fully utilised.

Activation keeps the battery in shape

The short, intense discharge pulses that prevent sulphate formation are generated by FET switch IRFZ48N, which practically short-circuits the battery across low-value resistor R2 (0.1 Ω) to generate a current of approximately 100 A depending on the internal resistance of the battery. The FET is driven by the other half of MOSFET driver IC2. As with the BUZ11 drive circuit, a protection resistor is included in the gate circuit to limit the drive current arising from the gate capacitance. The IRFZ48N shrugs its shoulders at these high-current pulses, since its maximum rated current for short pulses (less than 300 µs) is 240 A.

As storage capacitor C7 also supplies current during the initial portion of the pulse and the measurement for determining the pulse current must be made when the current is steady, a pulse width of 200 µs is used instead of the usually recommended value of 100 µs. The battery voltage is measured first under full load at 100 µs when the current has settled to a steady state, and the voltage on the drain lead of the FET is measured next. The voltage drop across R2 corresponds to the pulse current. As this wire-wound resistor has a non-negligible inductance, large voltage transients occur during switching. They are limited to 18 V by the overvoltage protection diode D10. The BUZ11 and the MOSFET driver IC are protected similarly by diodes D9 and D11.

The circuit can be powered from the

AC adapter or directly from the battery. The higher of the two voltages is fed to the 7805 voltage regulator (IC3) via diode D1 or D2 and converted into a stabilised 5-V supply voltage. The input voltage of the regulator is limited to 15 V by D11 in order to protect it against voltage spikes from the boost converter and the battery activator. This also limits the supply voltage for the MOSFET drivers, while capacitors C9 and C10 connected to the supply line for the drivers ensure that they can deliver adequate pulse energy.

The firmware for the PIC controller, which is described below, is downloaded using RB6, RB7 and the MCLR pin. The Reset button in the circuit is only used for testing and is entirely unnecessary during normal operation.

The intelligence is in the firmware

The firmware is written in Pascal and makes good use of the peripheral functions of the microcontroller. Beside the I/O ports, the timers, ADC, comparator, reference source and PWM module are all used. Only one-third of the flash memory and RAM capacity is used, so there is still plenty of room for extensions or optimisation.

After initialising the microcontroller and LCD module, the firmware runs in an infinite loop. In this loop, the timers are first configured for 50 ms, 1 s and 10 s. The charging routine, float routine or AC dropout routine is then executed at 1-second intervals depending on the battery status.

If the status is '1', the battery is charged using the IU_0U_p curve, which means at a constant current of 2 A until the battery voltage reaches 14.4 V. When this voltage is reached, charging continues at a constant voltage until the current drops to 0.2 A. After this the circuit switches to float charge mode.

When the status is '2', the battery voltage must be maintained at 13.2 V. For this purpose, the boost converter generates a series of four 2-A pulses with a pulse width of 50 ms if the voltage

About the author

Walter Trojan has been closely associated with electronics and IT during his entire professional career. He is a passionate hardware designer, and he enjoys implementing his own firmware. For instance, he built his own Z80-based computer at the beginning of the PC era, including writing a suitable BIOS. His best project is probably his web mains socket, which can be controlled via a LAN or the Internet and can send alarm messages via e-mail. He recently developed a radio-controlled heating system controller for a friend.

In recent years, the author has been using PIC microcontrollers by preference due to their flexibility and good peripheral function sets. As a veteran Turbo Pascal and Delphi enthusiast, the author's favourite firmware development tools are Mikroelektronika's Pascal compiler and Microchip's MPLAB environment with the C18 compiler.

is below the target level. This pulse charging also helps prevent sulphate formation on the battery plates. A short, intense discharge pulse is generated every 10 seconds by the battery activation function. The current during these pulses is computed from the voltage drop measured across R2. To obtain an indication of the health of the battery, the firmware stores the highest measured value in the EEPROM of the microcontroller and compares the currently measured pulse current with the stored value. If the internal resistance of the battery increases over time, its capacity and the pulse current will decrease. Although the ratio of the current and maximum values (in percent) is not an exact representation of the capacity, it can be used to assess the condition of the battery.

If the AC adapter does not provide any voltage, the status is '3' and the boost converter and activation function are disabled.

The display is also updated at one-second intervals according to the status and the measured parameters.

With each pass through the loop, the firmware uses the internal reference source and comparator to check whether the output voltage of the boost converter is above a defined maximum threshold. If it is, the firmware resets the PWM signal for the boost converter to prevent the voltage from rising to a level that could damage other components, which for example could happen if the battery is disconnected.

To prevent corruption of the voltage measurements by voltage spikes from the boost converter, the firmware disables the converter for approximately 50 μ s each time it makes a measurement.

The hex file and source code can be downloaded from the *Elektor* website. The Mikroelektronika Pascal compiler was used to generate the firmware. A free demo version can be downloaded from the Mikroelektronika website, but it is limited to a maximum hex file size of 2 kwords. Unfortunately, the pro-

gram for this project is larger than this limit and can thus only be recompiled with the full (pay) version.

Easy startup

The only alignment required is to adjust the reference voltage with trimpot P1 in order to ensure accurate measurements. To do this, connect a battery (which may be partly discharged) to the circuit board without connecting an AC adapter. The circuit will switch to status 3, no significant current will flow, and the open-circuit voltage of the battery will be shown on the LCD module. Using a multimeter with sufficient accuracy and resolution, measure the battery voltage and adjust trimpot P1 until the displayed value matches the measured value. If you now connect an AC adapter with an output voltage of 9 VDC and a capacity of around 36 watts, the charging process using the $I_{U_0}U_p$ charging curve will begin.

(07046-1)

Caution: a charged lead-acid battery stores an immense amount of energy, and an accidental short circuit can have a catastrophic effect. Consequently, a fuse must always be fitted in the battery lead (usually the positive lead). A slow-blow fuse with a rating of 30 A to 60 A should be used, depending on the capacity of the voltage converter used in the system.

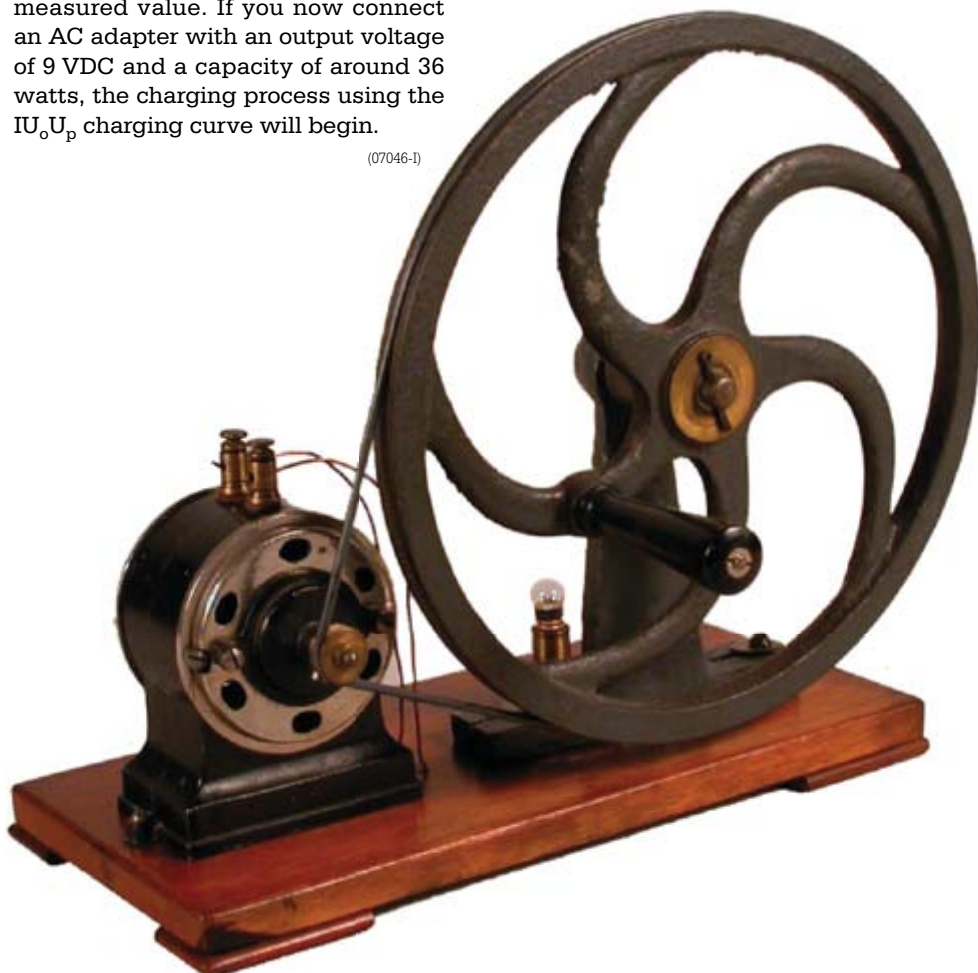



componentbin.com

Online Store!

Our online store contains an ever expanding variety of products designed for engineers, hobbyists and students. These include:

- ARM Development Systems
- Ethernet Modules
- RF Modules
- Graphic LCD Displays (With example software!)
- Home Automation
- Power Conversion
- Components & Connectors
- And Much More!
- Educational Discounts Available

Full product support with reference software and secure online ordering to kickstart your development.

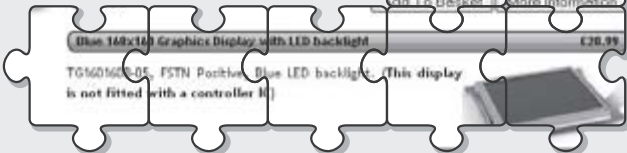

www.componentbin.com

+44 (0) 1354 778224



EzPCB
Professional PCB Supplier

**High Quality
Competitive Price**

URL: www.EzPCB.com

Email: sales@ezpcb.com Tel: +86 139 1002 1704
HDI Up To 50 Layers, 2.5mil T/C, 0.1mm Hole Size
Other Products: Stencils, Keypads, Frontpanels, Flex PCB, Enclosures, Turnkey Services

Microchip PIC Boards

Embedded webservice
USB, Ethernet
Dallas 1-wire
RS232/485, I2C
CAN-BUS
Serial LCD



Free project download with source code

ARM Development Boards

High performance 32bit RISC
USB JTAG
Ethernet and USB
RS233, I2C, CAN-BUS
NXP LPC and Atmel SAM



Free C compiler and IDE
Free ARM7 tutorial download

Embedded Linux Boards

Low cost embedded Linux board
Two USB host interface
Two 40 pins sockets for expansion
GSM / GPS Module add on
Create CGI using C language
Apache, PHP and SQLite
RSS Reader and LCD demo



Free SDK compiler download

Secure online ordering

www.skpang.co.uk
sales@skpang.co.uk



FRONT PANELS & HOUSINGS

Cost-effective single units and small production runs

Customized front panels can be designed effortlessly with the Front Panel Designer. The Front Panel Designer is available free on the Internet or on CD.

- automatic price calculation
- delivery in 5-8 days
- 24-Hour-Service if required



Sample price: 32,50 € plus VAT/shipping

Schaeffer AG · Hohentwielsteig 6a · D-14163 Berlin · Tel +49 (0)30 8 05 86 95-0
Fax +49 (0)30 8 05 86 95-33 · Web info@schaeffer-ag.de · www.schaeffer-ag.de

A whole penguin on half a credit card i.MX21 ARM9 Linux-board

Paul Goossens

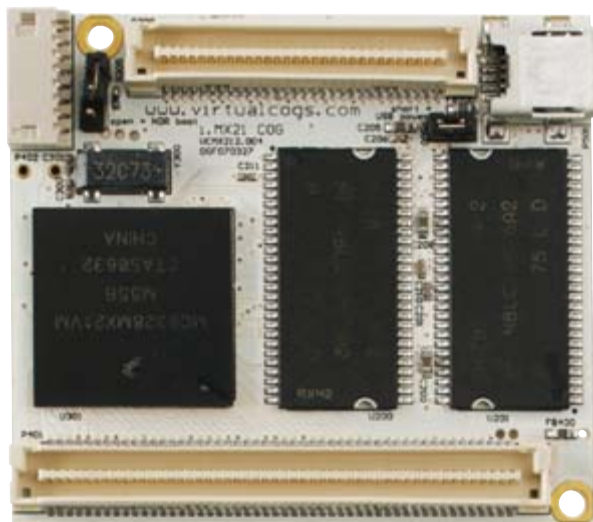

The development of a Linux based device is not something that suits everyone. You need considerable knowledge about the inner workings of the Linux kernel. The design of the necessary hardware is quite a job as well. For just over 165 dollars you can buy a complete Linux system with an ARM9-controller from Virtual Cogs. We subjected this system to a close examination in our lab.

The Canadian company Virtual Cogs can supply a controller board, which has the order number VCMX212, and is based on an i.MX21 (Freescale ARM9 controller) with a clock frequency of 266 MHz. The memory on this board consists of 64 MB of SDRAM and 16 MB of flash. All of this (and a little more, but more about that later) is the same size as half of a credit card!

Full-Linux

Most customers will buy this board because of the possibility of running Linux on it. When delivered, the flash memory already contains a bootloader plus a Linux operating system. The source code for this is freely available of course. The microcontroller used here is provided with an MMU (Memory Management Unit), so that a normal Linux version can run on it. This is in contrast to many other controller boards that use uC-Linux.

The big advantage of this system is that on the basis of this much more robust applications can be written. In addition, all the customary drivers (modules) can just be used as well.

uMON

The bootloader that's factory provided is uMON. This bootloader is responsible for the initialisation of the memory and can optionally start Linux.

In addition to using Linux, the designer also has the option of writing firmware that runs without an operating system. uMON has its own file system, is named TFS, that is used to store various programs in flash memory. In a standard

Linux system these are the Linux kernel and an image of the Linux file-system. Additionally you can store a start-up script that describes how uMON has to start Linux. This makes booting Linux very easy.

It is also possible to use the file system in uMON from your own firmware. An API is available for this purpose which allows files to be created, read, written and deleted in the TFS file-system.

With the aid of a terminal program, such as Hyperterminal, you can easily upload and download programs to and from the TFS file system. We refer you to the website of uMON for more details about other features of this bootloader.

In the event that the flash memory is accidentally erased, perhaps after a failed experiment, (despite the hardware protection against unwanted erasure) then all is not lost. The controller itself also has an internal bootloader that cannot be erased. Using this bootloader the flash memory can be restored again.

Hardware

The hardware of the VCMX212 consists of the above mentioned i.MX21 controller, 64 MB SDRAM and 16 MB of flash memory.

In addition there is also a USB to serial converter from Silabs, the CP2101. For Vista users it is good to know that Silabs are, at the time of writing this article, still busy with the development of a suitable driver for Windows Vista. The planned release date for this driver is around the end of 2007.

Another method of programming the controller is via the JTAG connector. This also offers the possibility of debugging

the controller in real-time, provided that a suitable JTAG interface with corresponding software is available.

The board can be powered from the USB connection. If more power is required it is possible to switch to an external power supply.

As a bonus the board is also fitted with 3 LEDs, which can be used as status indicators, for example.

Most of the important signals are available via two connectors to which hardware expansions can be connected. You can make these yourself, but various daughter boards are also available ready-made from the manufacturer.

Expansions

Virtual Cogs have developed a number of daughter boards for the VCMX212. These are all supported in Linux, so that using these is not too complicated.

One of these expansions is a graphics screen, either with or without a touch panel. This expansion board also comprises an audio codec with built-in microphone.

In addition there is a camera module, an Ethernet module and a break-out board. The latter is very useful if you would like to develop hardware yourself for this system. The break-out board conveniently routes all relevant signals to standard through-hole pin headers. This greatly facilitates connecting your own prototype expansion circuits.

For a complete list of expansion modules it is best to visit the Virtual Cogs website. New expansion boards for this system appear at a regular basis.

Development environment

The development of software for this module is possible with both Windows XP and Linux. According to some reports it is also possible to use this development environment with Windows Vista, but we did not try that ourselves.

The installation procedure for installing the (open source) development environment can be found on the Virtual Cogs website. This contains, among other things, Cygwin and gcc-arm. If you have the intention of writing Linux programs, then it is necessary to compile gcc yourself. This is very easy with the aid of the supplied script. It can take a considerable amount of time however.

Flash file system

The Linux system uses the comfortable JFFS2 file-system in combination with MTD to store files. This means that it is possible to create and delete files while running Linux. This behaves the same as if there was a hard disk installed. This sounds logical, but on many embedded Linux devices it can be quite an exercise to change files, etc. in flash memory.

With this Linux it is simple to do file operations via Hyperterminal with Y-modem protocol. In the event that the Ethernet expansion board is also fitted, files can also be exchanged via ftp or even NFS.

Support

The manufacturer maintains a Wiki with all the relevant information concerning the VCMX212 and corresponding expansion boards. The manuals for the various products are also available online.

All the required information to get the development started quickly and without problems is available here.

Linux versus μ C-Linux

In embedded system μ C-Linux is often used in place of 'normal' Linux. μ C-Linux is derived from Linux and modified so that this kernel can be used with controllers that do not have an MMU.

This means that under μ C-Linux all applications share the entire memory space with each other. An error in one application can result in the corruption of memory of another application. This can lead to problems that are very hard to solve. This system offers also no separation of the hardware from the application software. Under μ C-Linux the hardware can be controlled directly from the application without the intermediate layer of the operating system. This means another big hole in the security.

Finally we have to mention that not all software that has been written for Linux can be used with μ C-Linux just as it is.

Verdict

After carrying out a few experiments we are of the opinion that this board is very suitable for use in your own devices. In particular designers with some experience with programming under Linux will certainly appreciate this hardware.

The board can also be used by users who are familiar with the C programming language. It is, after all, possible to ignore Linux completely (initially) and write pure firmware yourself. Nonetheless, we recommend that in this case that you invest some time to explore programming under Linux. This really allows you to use the power of this board to its fullest.

The support for this product by the manufacturer can be called very good. Their Wiki site contains all the information to get you started quickly. And you can also count on the forum for support!

(070243-1)

The i.MX21 board costs US\$ 164.95 plus (VAT and shipping) from Sparkfun.

Web Links

μ MON:

<http://www.microcross.com/html/micromonitor.html>

Virtual Cogs:

<http://www.virtualcogs.com>

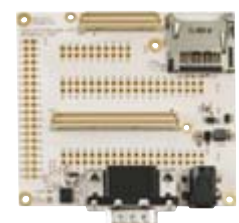
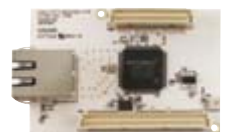

i.MX21 controller

The i.MX21 controller from Freescale is a powerful ARM9 controller with a maximum clock speed of 266 MHz. This controller has a number of additional features that make it eminently suitable for multimedia applications.

The chip has a video-accelerator on that can (de)code MPEG-4 video in real-time at QGA resolution. It also has an LCD interface and a CMOS camera interface.

Communications have not been forgotten either. What do you think about no less than 4 UARTS, I2C-interface, IrDA, USB-OTG and 1-wire?

LED's Dive!

Underwater torch using Luxeon LEDs

Erik Bonjean

It can often be fairly dark under water, especially at greater depths. A diving torch is essential if you want to be able to enjoy the marine scenery (or to help with a rescue operation). It's easy to go out and buy a new lamp, but an old one still has its uses too! More so if we add some powerful LEDs.

The secrets of the marine world are often hidden in the darkness. A decent diving torch will help reveal them as it brings some light to the darkness. In this article we'll describe a battery powered diving torch that uses a simple, easy to build circuit and an existing housing from an old diving torch, an OceanPro made by Scubapro. Some older divers may well have one of these in the loft somewhere. The circuit presented here fits exactly into the housing of this torch. But there's nothing to stop you from putting this circuit into a different torch.

Operation

The light in this circuit is generated by seven 3-watt Luxeon LEDs connected in series. If you feel this doesn't provide enough light you can always increase the number of LEDs, since the power comes from a constant current source. The power consumption will obviously increase as well, and eventually the boost converter will reach its (voltage) limit. In the circuit described here the output voltage is 23 V and the current at

this voltage is 630 mA. This results in a power of 2 W per LED, which is more than sufficient and keeps the heat generated in the LEDs down to a reasonable level.

This voltage is generated by an LT1070 made by Linear Technology (see **Figure 1**). This switching regulator is configured as a boost converter and provided with current limiting. This current is determined by four resistors connected in parallel, R1 to R4.

D2, D3 and R5 are used to turn off the LT1070 when the battery voltage drops below about 10 V. D3 pulls V_C low when the supply voltage drops below $(1.5 V +$

$V_{Z,D2})$ and this turns off the IC. There is no hysteresis built into this circuit, so the light will start flashing when the battery is nearly empty, providing an early warning. This circuit also protects the battery from being discharged too much. Without this protection circuit the light would turn off suddenly when the input current to the regulator would increase too much due to the decreasing input voltage. This is rather inconvenient when you're in the

darkness, a long way under water.

The rest of the circuit functions like any other standard boost converter. The internal switch of the LT1070 can handle up to 5 A.



The input voltage is boosted by inductor L1 in conjunction with this switch. The amount of boost is determined by the duty cycle applied to the switch. The appropriate formula is:

$$V_{OUT} = V_{IN} / (1-d.c.)$$

where d.c. is the duty cycle. Capacitors C1 and C2 smooth the input and output voltages. In this application the LT1070 doesn't really need a heatsink, but you can add one to be on the safe side.

The supply is provided by 12 NiMh cells connected in series. This provides a voltage of 14.4 V. The batteries are connected to the circuit via K1. A battery charger may be connected to K3. The efficiency of the converter is between 80 and 85%, depending on the input voltage.

Construction

The construction of this circuit is very straightforward (Figure 2). The standard components won't cause any problems with soldering and there is also plenty of room available (see Figure 3). As usual, it is easiest to start with the smallest components, in this case the diodes and resistors. Considering the size and weight of the inductor, it is best to leave this till last.

The series connected LEDs are mounted on an aluminum disc, which has rubber rings on both sides that provide a seal between the housing and the polycarbonate faceplate. The LEDs are mounted behind collimator lenses made by Carclo. These bundle the light from the LEDs together, which would otherwise form a beam with too wide an angle. The LEDs are connected to the converter circuit via K2.

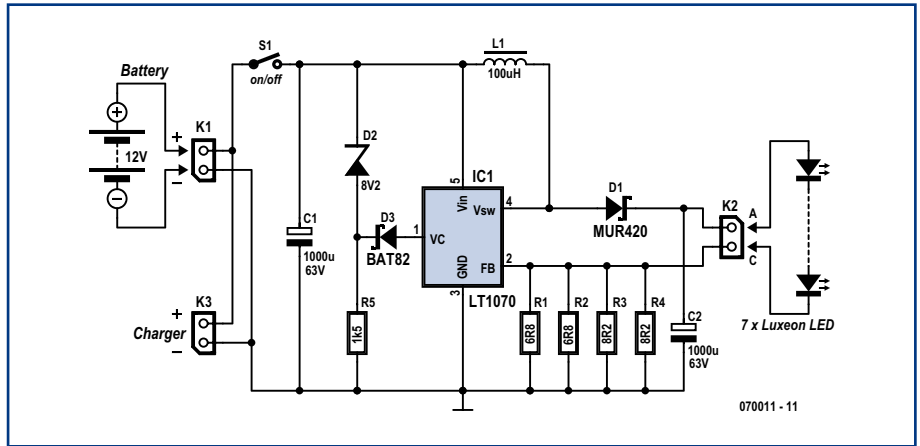

Figure 1. This simple boost converter fits easily inside the diving torch housing.

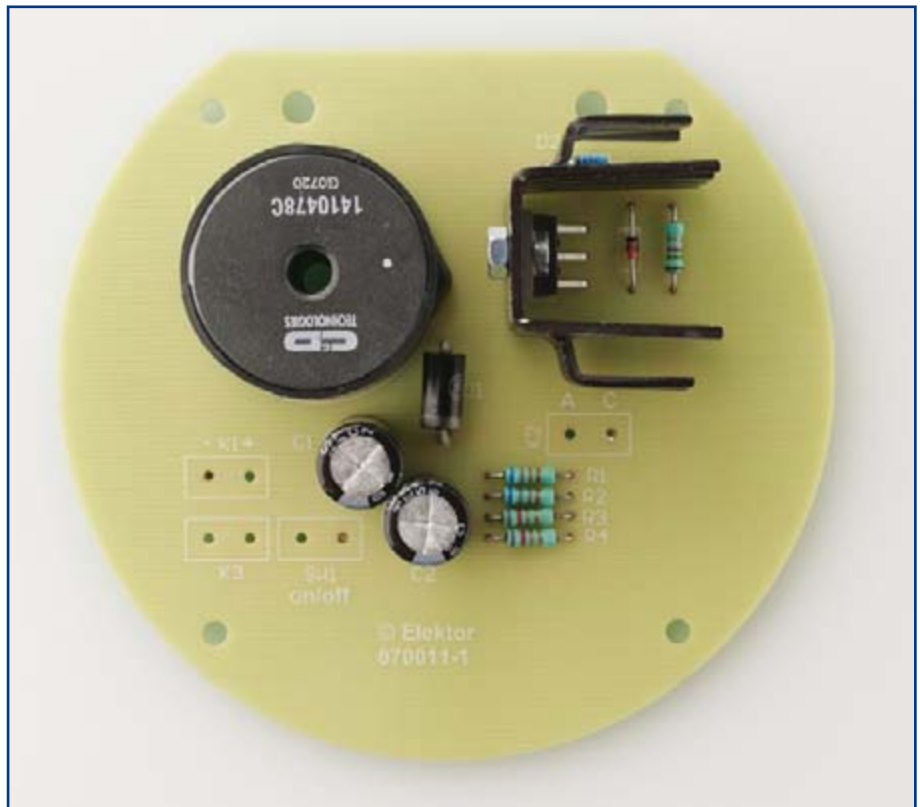

Figure 2. The size of the board gives plenty of room for all components.

COMPONENTS LIST

Resistors

R1,R2 = 6Ω
R3,R4 = 8Ω
R5 = 1kΩ

Capacitors

C1,C2 = 1000μF 25V radial

Inductors

L1 = 100μH (C&D Technologies type 1410478C)

Semiconductors

D1 = MUR420
D2 = zener diode 8V2
D3 = BAT82
IC1 = LT1070
D4-D10 = Luxeon Star 3W LXLH-LW3C

Miscellaneous

7 x collimator lens, 15°, Carclo part # 10003/15
7 x lens holder, Carclo part # 10043
PCB, ref. 070011-1 from www.thePCBShop.com

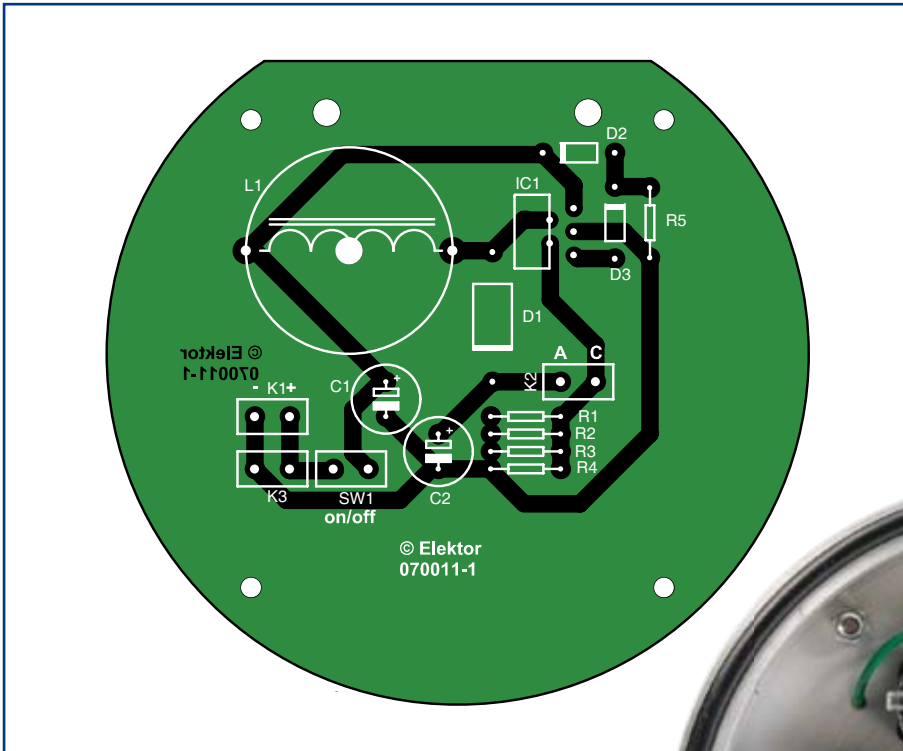

Figure 3. The shape of the board has been made to give a good fit in the torch housing.

In practice

You will find that the LEDs become noticeably dimmer when the batteries are nearly empty. The LEDs will remain lit at the lower voltage, so there is enough time to get back to the surface.

The NiMh batteries may be charged with a standard charger via K3. For the connection we would recommend a waterproof RCA plug. It is best to use a gold-plated type, as that will prevent corrosion.

The board layout may be freely downloaded from the project page on our website at www.elektor.com. The ready-made, bare PCB may be obtained from ThePCBShop (www.thepcbshop.com).

(070011-1)

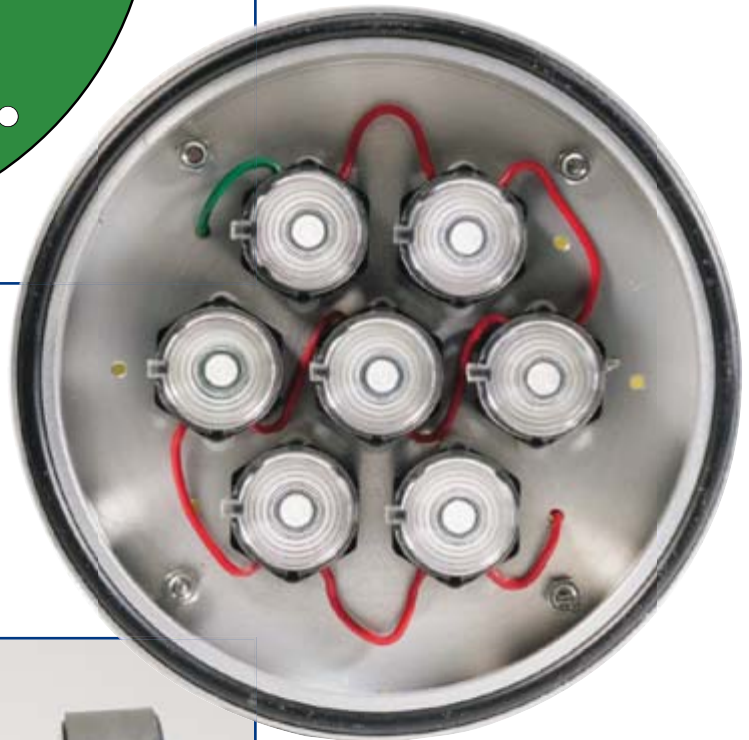

Figure 5. The LEDs are mounted on a large aluminium disc, which also acts as a heatsink.



Figure 4. A number of spacers and long screws give a solid construction and a snug fit in the housing

Web Links

www.elektor.com

www.linear.com

A Mini DI

Florian Gerstenlauer

The 'DI' in the title stands for Direct Injection, a term used in audio engineering. Many DI boxes have appeared in *Elektor* over the years and their function is basically to take a single-ended signal (i.e the signal and earth output from, say, an amplifier output) and convert it into a symmetrical (earth-free) signal suitable for the microphone input of a mixer. The simplest solution would be to use a transformer; an electronic solution requires a circuit which has differential outputs. A ready-made IC like the SSM2142 or DRV135 from Analog Devices and Burr Brown/TI is another alternative but the basic DI box function can also be built with discrete components using just two transistors as described here. Built with SMDs the resulting PCB is so small (see photos) that the entire circuit fits inside the housing of a 6.3 mm jack plug (this particular model is made by Neutrik but other makes of plug are also suitable). The big advantage of this solution is its simplicity, it reduces stage clutter; no batteries, no additional equipment or power supplies just a single cable is all you need to do the job. The circuit consists of a differen-

tial amplifier formed by T1/T2, which converts the single-ended line signal into a symmetrical (microphone) signal. The 48 V power supply for the circuit comes from the phantom power facility found on most modern mixer desks or microphone pre-amps and is normally provided to allow the connection of condenser mics. The 48 V DC

R2, R9 and R10 together with C2 produce a smoothed base bias voltage for the transistors of around 22 V which is connected directly to the base of T1 and via R4 to T2. The line input signal is divided down by potential divider R4/R5 and the input impedance of T2 which results in a 16 times reduction of the signal and

to the input. The values of components R4, R5, R11 and C1 can be altered to optimise performance for a particular application. The values given have proved to be a good compromise. Some semi-professional equipment may require the MiniDI to have less attenuation and higher input impedance which can be achieved by increasing the values of R11 and R4. The value of R5 should be increased if the MiniDI is connected directly to an amplifier output, in this case the value of C1 can also be reduced. R8 acts as 'Groundlift' which helps to reduce hum on the signal. The value of this resistor should be greater than the contact resistance of the connector, the value of 10 Ω shown should be ample. The 100 nF capacitor in parallel with R8 maintains RF continuity in the shield. The BC850C is a low noise NPN transistor with a saturation voltage V_{CES} of 50 V and has high gain. The BC846B can be substituted here; it has a higher maximum saturation voltage of 80 V and uses the same pin-out but has slightly less current gain. Visit www.elektor.com to download the SMD PCB pattern for free.

(070147-1)

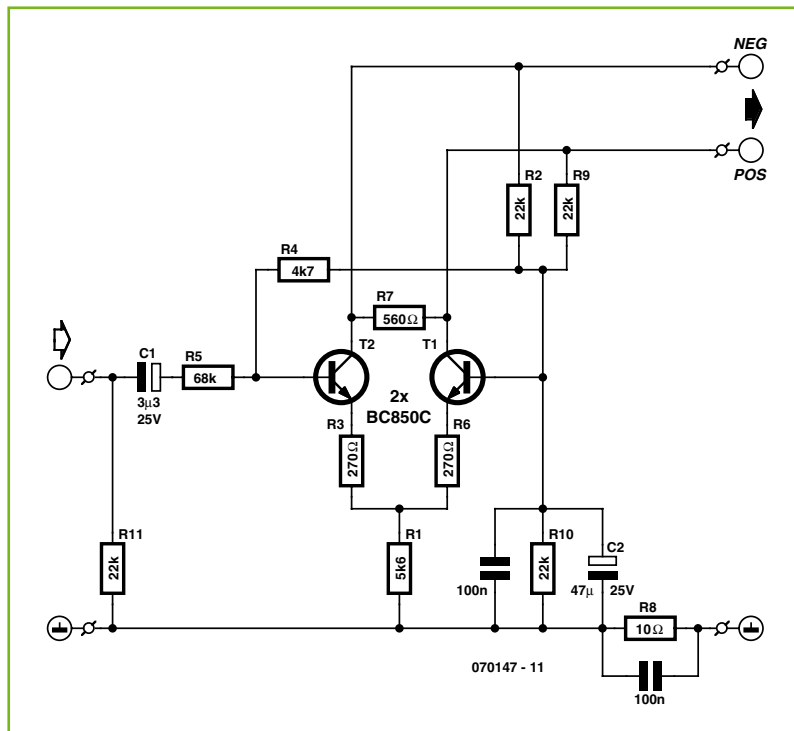

connects to the two symmetrical microphone signal wires via 6.81 KΩ resistors inside the mixer and these act as the collector loads in the differential amplifier of our MiniDI circuit.

produces a level more suitable for the input of a microphone preamplifier. C1 decouples any DC offset on the input signal and R11 ensures that C1 is discharged if nothing is connected

saturation voltage of 80 V and uses the same pin-out but has slightly less current gain. Visit www.elektor.com to download the SMD PCB pattern for free.



LED Brake

Marcel Ulrich

LEDs are used more and more in motor vehicles, replacing the standard incandescent lamps because they are more energy efficient and have a much longer life expectancy. In this article we describe a simple LED tail light that has been specifically designed for motorcycles, scooters and mopeds.

There appears to be a significant need among motorcyclists for rear lights with LEDs, as evidenced by the many messages on this topic that turn up in various internet forums. The circuits that accompany these messages are often very rudimentary and therefore not very robust.

When designing an LED light for a motorcycle the following criteria need to be considered:

- Large variations of on-board voltage, this has a significant influence on light intensity.
- The circuit has to be (mechanically) robust.
- High light output is required (visibility = safety).
- Clearly visible difference in light intensity between rear light and brake light function.

After reading some of the literature concerning the use of LEDs in motor vehicles, it appears that the most common reason why LEDs still fail is the incorrect and/or insufficient use of series resistors.

In poorly implemented circuits there are often a number of LEDs connected in parallel which are all fed from a single series resistor. Because of small variations between LEDs, one LED can quickly give up the ghost. This causes an increase in current through the remaining LEDs and can easily lead to a domino effect, ultimately resulting in the failure of the entire circuit.

With high-intensity LEDs, a small variation in current is immediately obvious as a large variation in light output. This has to be taken into account when designing a circuit. This is important because when the engine rev speed goes up, the on-board voltage increases significantly. It would appear that you were braking when you actually opened the throttle instead. LEDs need mainly a constant current. That is why most circuits choose to drive LEDs from a constant-current source.

Circuit

This circuit has been designed to operate both as a motorcycle rear light and

as a brake light. This requires two different currents. Because the voltages measured on the author's motorcycle varied from 10.5 to 15 V and because two different currents are required for the total of 17 high-intensity LEDs it was not possible to use only one constant-current source.

The idea was to turn the strongly varying DC voltage into a nice constant voltage first and then turn that into a constant current through a number of series resistors.

The problem that is highlighted in many forums is the fact that the signal for the brake light is a positive voltage. It would require a lot of work on the motorcycle to change this. That is why the decision was made for a design that regulates the voltage on the chassis side, with the aid of a negative voltage regulator, a 7908.

The disadvantage of this arrangement is that an additional chassis wire is required; normally the minus side of the lamps is directly connected to the chassis of the motorcycle.

However, the advantage is that both the + from the rear light as well as



Brake/Rear Light

Specifically for motorcycles



the + from the brake light can be directly connected to the LEDs.

The 'lamp' consists of a centre part with nine round, red, 5-mm LEDs (HLMP EG08-Y200) with positioned around that eight oval, red LEDs (HLMP AD61) of 5 mm.

The round LEDs D12 through D20 – which have quite a narrow radiation angle – are connected in series in sets of 3. Three of these 'strings' are connected in parallel and each string has its own series resistor.

The oval LEDs D4 to D11 – which have a wide radiation pattern – are connected with two in series, so there are therefore four strings connected in parallel. These ensure with their wide radiation angle of 110 degrees that the rear/brake-light is also clearly visible from the side.

The oval and round strings are connected to the brake contact via diodes. When the brake is operated all the strings are presented with the +12V from the battery via the series resistors. The light intensity therefore depends on the current that flows as a result of the series resistor (and the voltage drop across the diodes).

When the brake is not operated, the LEDs strings are still connected to the positive voltage of the battery, but this time via additional resistors R1 and R2. Because of the value of these resistors, the current is much lower and therefore also the light intensity.

The intensity of the brake light can be adjusted using the series resistors (R3

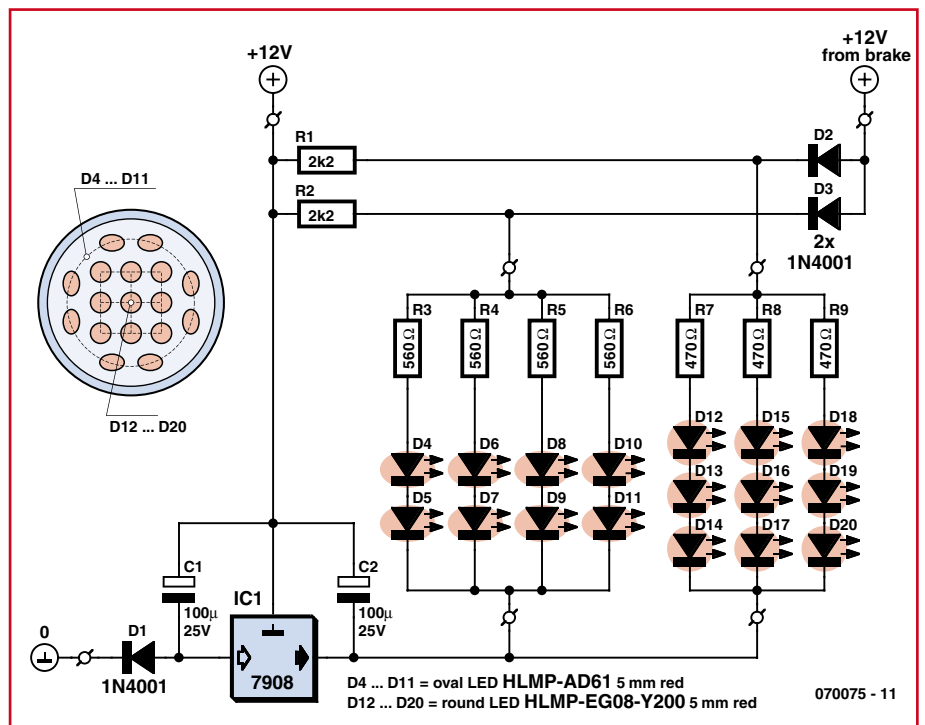

Figure 1. The schematic for the circuit. The voltage regulator provides voltage regulation on the minus side of the on-board voltage.

to R9) in each of the individual strings, the brightness of the rear light is selected with the additional series resistors R1 and R2.

Diode D1 has been added to protect the circuit from reverse connection of the power supply voltage. Electrolytic capacitors finally provide filtering for the fairly large varying, and not so clean, voltage.

The circuit was built into a silver-coloured tube by the author. The electronics are mounted on two pieces of prototyping board, one behind the other, in the tube. The front (visible) PCB holds the LEDs and the series resistors. The LEDs are arranged as indicated next to the schematic. The 9 round LEDs are mounted in the middle of the rear light in a square pattern. The oval LEDs are mounted in a circle around the square.

The second PCB contains the remaining parts and the regulator.

You can modify the circuit to your heart's content by adding more strings, each fitted with its own diode and two resistors (a series resistor such as R3) and a resistor to +12 V (such as R1). The total current (when braking), must not exceed the maximum rating of the voltage regulator, this amounts to 1 A.

(070075-1)

IC-free (almost)

Luc Lemmens

The PCB drilling machine speed controller described in this issue generated quite a bit of discussion among the editorial staff. A glimpse behind the scenes...

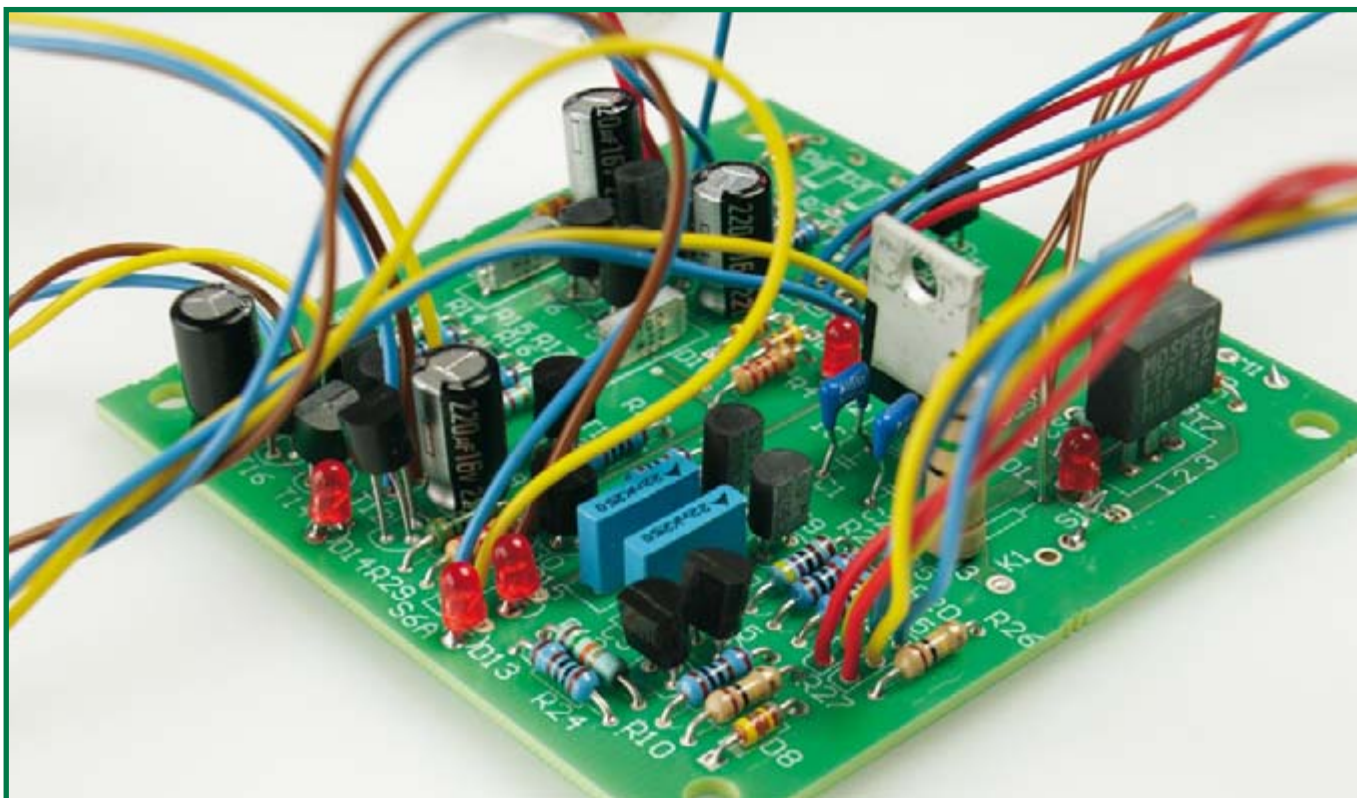

First off, there was disagreement regarding the technology that was used: the only IC in the circuit is a voltage regulator. Everything else consists of discrete components. One comment was, 'Shouldn't you use a microcontroller for that nowadays?' Although there is something to be said for this approach, it can't hurt to show how a controller of this sort can be built without using ICs and programmable logic. However, we have to admit that it's been a long time since we had to dig into the potentiometer and BC5xx drawer so often for a magazine project. The controller is made entirely from standard parts, which most of us should already have on hand somewhere.

Another comment was, 'What a lot of switches and adjustments!' That's true, but this is unavoidable if you want to make the type of controller the designer had in mind. It also means that it will take a bit of effort to adjust the circuit to the desired speed profile. However, the same holds true of a circuit built using integrated circuits, and in the latter case a complicated menu structure would probably be necessary. In this regard, old-fashioned rotary knobs aren't such a bad idea.

There was also a debate at a more fundamental level: is it actually worthwhile to fit a PCB drilling machine with a speed controller? Will the drill bits last longer if you constantly vary the speed, or will there be less wear if they always run at the same speed? We didn't try to answer this question with any experiments or studies, but according to the designer the circuit is definitely beneficial. We are very interested hearing from our readers about their experience!

In response to the question as to whether we personally use this circuit for drilling prototype PCBs, the answer is very short: no. This has nothing to do with whether we personally believe in the circuit, but

is instead entirely due to a different way of working and developing PCBs. Previously we had a separate room with exposure equipment, an etching machine and a PCB drilling machine, but that's now past history. Most of the PCBs we design nowadays are double-sided and through-hole plated, and we anyway never had the equipment in house that you need for the latter process. We usually handled this by bearing in mind that it's easy to do manual 'through-hole plating'. For instance, you can connect the top and bottom sides of a board at locations where component leads can be soldered on both sides. Where this is not possible, we used thin copper wire to make a connection between the two copper layers. Although this is a bit more difficult, it's a workable solution. In the future, multilayer boards will be used increasingly often in our projects, and then these simple remedies will be completely useless.

Even the single-sided PCBs that we made in our etching room were frequently a source of problems. It's easy to make a mistake during etching, and tracking down a fault on a poorly etched PCB can consume an enormous amount of time. This is why we have definitively switched to external PCB suppliers, including for production of our prototype PCBs. Of course, it takes a while before you have a board in house, and the costs mount up quickly if you want to have it fast, but in exchange for this you have a quality product – and that ultimately saves a lot of time in circuit testing. Naturally, this approach requires more discipline and checking before you decide that your board design is good enough, since quickly etching a new PCB is simply no longer possible.

(075104-1)

08717 Credit Card **177 168**
Sales



Ho! Ho! Ho! Christmas 2007 is on it's way
BUT DON'T PANIC!!

We have some fantastic gift ideas for young (and old) enquiring minds



Electronic Project Labs

An electronics course in a box! All assume no previous knowledge and require NO solder. See website for full details



30 in ONE - £16.95
Order Code EPL030KT



130 in ONE - £39.95
Order Code EPL130KT



300 in ONE - £59.95
Order Code EPL300KT



500 in ONE - £149.95
Order Code EPL500KT



Robot Sensor - £19.95
Order Code EPLR20KT



Digital Recording Laboratory - £29.95
Order Code EPLDRKT

Solderless Electronic Project Kits



AM-FM Radio Kit - £6.95
Order Code ERKAFKT



Short Wave Kit - £6.95
Order Code ERKSWKT



Crystal Radio Kit - £6.95
Order Code ERKCKT



Electronic Bell - £8.95
Order Code EAKEBKT



Electronic Motor - £8.95
Order Code EAKEMKT



Generator - £8.95
Order Code EAKEGKT



Room Alarm - £4.95
Order Code EAKRAKT



Hand Held Metal Detector - £9.95
Order Code ELMDX7KT



Metal Detector - £9.95
Order Code ELMDKT

Mechanical Motorised Wooden Kits

Future engineers can learn about the operation of transmissions steered through gears or pulleys. Easy to build, no glue or soldering required.



Automech - £12.95
Order Code C21-605KT



Coptermech - £12.95
Order Code C21-604KT



Trainmech - £12.95
Order Code C21-606KT



Robomech - £12.95
Order Code C21-603KT



Stegomech - £12.95
Order Code C21-602KT



Tyrannomech - £12.95
Order Code C21-601KT

Festive Electronic Project Kits



Musical LED Jingle Bells - £17.95
Order Code 1176KT



Flashing LED Christmas Tree - £6.95
Order Code 4080KT

See our website for even more great gift ideas!



www.QuasarElectronics.com

Secure Online Ordering Facilities • Full Product Listing, Descriptions & Photos • Kit Documentation & Software Downloads

Hexadoku

Puzzle with an electronics touch

For the dark days before Christmas, here's another fine Hexadoku — just the thing to have if you want to get off programming or soldering for an evening or two. Send us your solution and enter a prize draw for one of the prizes: an E-blocks Starter Kit Professional and three Elektor Shop vouchers.

The instructions for this puzzle are straightforward.

In the diagram composed of 16 x 16 boxes, enter numbers such that **all** hexadecimal numbers 0 through F (that's 0-9 and A-F) occur once only in each row, once in each column and in each of the 4x4 boxes (marked by the thicker black lines).

A number of clues are given in the puzzle and these determine the start situation.

All correct entries received for each month's puzzle go into a draw for a main prize and three lesser prizes. All you need to do is send us the numbers in the grey boxes. The puzzle is also available as a **free download** from our website.

SOLVE HEXADOKU AND WIN!

Correct solutions received enter a prize draw for an

E-blocks Starter Kit Professional

worth **£248.55**

and three **Elektor SHOP Vouchers** worth £35.00 each.



We believe these prizes should encourage all our readers to participate!

The competition is not open to employees of Elektor International Media b.v., its business partners and/or associated publishing houses.

PARTICIPATE!

Please send your solution (the numbers in the grey boxes) by email to:

editor@elektor.com - Subject: **hexadoku 12-2007**.

Alternatively, by fax or post to: **Elektor Hexadoku Regus Brentford - 1000 Great West Road - Brentford TW8 9HH United Kingdom - Fax (+44) 208 2614447**

The closing date is **1 January 2008**.

PRIZE WINNERS

The solution of the October 2007 puzzle is: **36784**.

The **E-blocks Starter Kit Professional** goes to:

Tommy Bryants (IRL).

An **Elektor SHOP voucher worth £35.00** goes to:

Shane Croot (UK); Marko Nykänen (FIN) and Gary Price (UK).

Congratulations everybody!

			B			F		A	1	8			C	3
3			A		9	B	D	5			F	1	E	7
	C			5	1	7		6	E			8		
	9	E	1			C	8			2	B			5
1			E	F	8		B	D						3
	3		8	C	0			F	4				7	2
		7				3			8	A			4	0
			4	D	2	A	7		3	5			C	E
F			3				0	A	6	E	5			9
			C	3	F				4		7	A		
	B			6	4	8				0			D	F
2	D	6			C	1	E		B				3	4
4				B	7				D	C	E			
B	5		7		E	9	A	2	F			4	6	
E			6	1	D	2		7				A	F	5
					3				6	A	C			E

(c) PZZL.com

A	8	3	5	4	0	B	C	9	7	2	F	D	6	1	E
9	7	0	E	A	1	6	8	D	B	C	5	3	F	4	2
4	D	C	1	9	2	3	F	E	6	8	A	0	7	B	5
F	6	B	2	E	5	7	D	1	3	0	4	9	A	C	8
5	9	F	0	7	8	D	6	A	C	3	2	4	1	E	B
1	B	2	6	3	9	F	4	0	D	E	7	5	C	8	A
C	A	E	3	0	B	5	2	8	1	4	9	F	D	7	6
8	4	7	D	1	C	E	A	F	5	B	6	2	0	3	9
7	2	A	4	6	3	8	1	C	E	5	D	B	9	F	0
B	E	9	8	5	F	2	7	4	0	A	1	C	3	6	D
3	5	D	F	C	A	9	0	6	8	7	B	E	4	2	1
6	0	1	C	B	D	4	E	2	F	9	3	8	5	A	7
2	1	8	B	F	7	C	5	3	A	D	0	6	E	9	4
E	F	5	A	2	6	0	9	B	4	1	C	7	8	D	3
D	3	6	7	8	4	A	B	5	9	F	E	1	2	0	C
0	C	4	9	D	E	1	3	7	2	6	8	A	B	5	F

Philips 'SXA' VHF/UHF Handheld (1977)

Jan Buiting

Philips Telecommunication Industries in their 1977 product information sheet write that the SXA is a *solid-state VHF/UHF personal FM radiotelephone with 5-channel capability, a transmitter power of 1 W or 2 W and a receiver with an audio output power of 500 mW. Handheld and bodyworn versions are available. Housed in a diecast frame with front and rear covers, the transmitter and receiver are fitted on separate boards which swing outward for easy servicing. Space is reserved on the transmitter board for fitting a tone oscillator. Selective calling options will also be available. ...*

The standard battery box secured to the underside of the radio (using a clever set of bayonet clips) contains two sets of five 500 mAh rechargeable NiCd cells. Versions with Varta 'button' cells are the most frequently seen, with Saft penlights as a rarer occurrence. Whatever brand, the cells are invariably 'gone' after 30 years, and you would be lucky to have the Saft variety as with a little ingenuity in opening and sealing the case, it allows internal replacement by AA size NiCds (or NiMHs) fitted with solder tags (DIY spot-welding!). An even better alternative however (but a rare find) is the third variant sold by Philips: an empty box in which you can slip 10 ordinary 1.5 V AA batteries or rechargeables.

The SXA was described by Philips as 'portophone', a word coined in the early 1950s by the company but never accepted in the Anglo-Saxon markets where 'handheld' prevailed. In Germany, the SXA was sold under the brand name 'TeKaDe'.

The radio was available in versions for the 80-MHz, 160-MHz and 450-MHz PMR bands, 12.5 kHz, 20 kHz, 25 kHz or 50 kHz channel spacing, and 1 watt or 2 watts RF output power, not forgetting bodyworn or handheld. The electronics inside are conventional 1970s style

based on Philips' own (well-reputed) components only. You'll find those fine BFY9x, BC54x and BF49x series transistors in combination with the odd 'TBA' integrated circuit. I can safely say that electrically an SXA is never beyond repair as only commonly available parts are used on two boards that are a joy to work on for repair or alignment, not in the least by the way they can be hinged out of the frame!

The SXA's transmitter and receiver are crystal-controlled using a conventional frequency multiplier scheme for the transmitter (x8) and a double-conversion heterodyne for the receiver. Quartz crystals for the SXA are still made by small companies who will surprise you by cheerfully pulling the specs from their 1970s archives.

The SXA is very solidly built and will take a real bashing before being condemned to acting as a paper weight, a doorstop or oblivion. Weighing 925 g including the loaded battery case it must have been less than a pleasure to carry around on a typical shift.

The photo shows two fairly rare 1.5-watt UHF (450 MHz) SXA radios reportedly used by tactical and engineering divisions of the Dutch army for their short-range communications. I've also heard of 80-MHz SXAs used by army base camp guard patrols, in which case the long antenna must have been very conspicuous! Until quite recently, 160-MHz SXA radios were in active use by Belgian airport customs and fire fighters.

Accessories sold for the SXA included 2-pod and 5-pod charging units, sellcall electronics, a leather & Velcro 'pouch', a lapel-worn remote control and a dummy battery unit for external powering by a 12-VDC PSU. The SXA could be ordered in any colour you wanted, as long as it was green.

(075106-1)

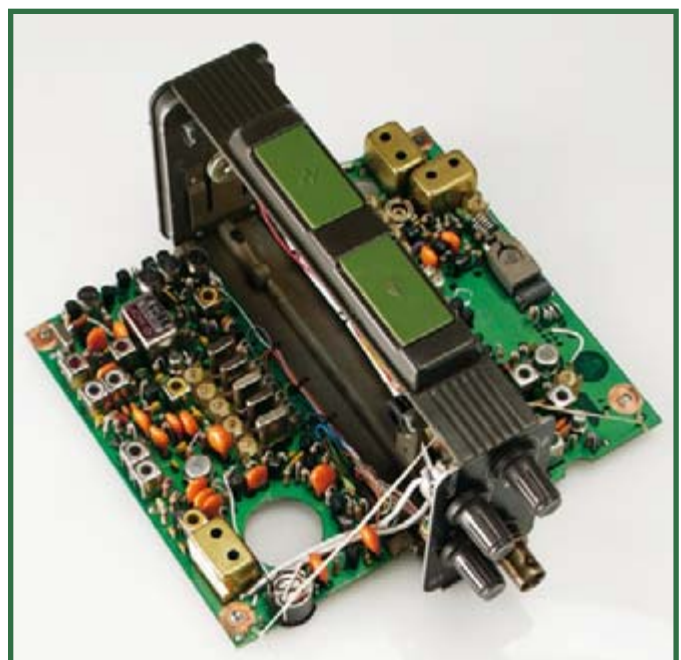

Retronics is a monthly column covering vintage electronics including legendary Elektor designs. Contributions, suggestions and requests are welcomed; please send an email to editor@elektor.com

ELEKTOR SHOWCASE

To book your showcase space contact Huson International Media

Tel. 0044 (0) 1932 564999 Fax 0044 (0) 1932 564998

ATC SEMITEC LTD

www.atcsemitec.co.uk

Thermal and current-sensitive components for temperature control and circuit protection;

- NTC Thermistors
- Current Diodes
- Thermostats
- Re-settable Fuses
- Thermal Fuses
- Temperature Sensors

Call today for free samples and pricing

Tel: 01606 871680 Fax: 01606 872938

AVIT RESEARCH

www.avitresearch.co.uk

USB has never been so simple... with our USB to Microcontroller Interface cable. Appears just like a serial port to both PC and Microcontroller, for really easy USB connection to your projects, or replacement of existing RS232 interfaces.



See our webpage for more details. From £15.00.

BETA LAYOUT

www.pcb-pool.com

Beta layout Ltd Award-winning site in both English and German offers prototype



PCBs at a fraction of the cost of the usual manufacturer's prices.

BOWOOD ELECTRONICS LTD

www.bowood-electronics.co.uk

Suppliers of Electronic Components

- Semiconductors
- Opto Electronics
- Passives
- Enclosures
- Switches
- Stripboard
- PCB Materials
- Popular Special Offer Packs

Online Store, all major cards

Same day despatch upto 3.00pm

Personal Service sales@bowood-electronics.co.uk

BYVAC ELECTRONICS

www.byvac.co.uk

32Bit ARM

Microcontroller, USB, built in RTC with it's own operating system, no complex tools, just a

terminal emulator, start writing programs in 20 minutes. Complete with CD-ROM, Software and 100 Page Foundation book



DECIBIT CO.LTD.

www.decibit.com

Smallest 2.4 GHz ISM band MCU embedded transceiver modules. Complete tiny solution, ready to transmit RF data by only attaching as example a CR2032 coin cell to it.



DESIGNER SYSTEMS

<http://www.designersystems.co.uk>

Professional product development services.

- Marine (Security, Tracking, Monitoring & control)
- Automotive (AV, Tracking, Gadget, Monitoring & control)
- Industrial (Safety systems, Monitoring over Ethernet)
- Telecoms (PSTN handsets, GSM/GPRS)
- AudioVisual ((HD)/DVD accessories & controllers)



Tel: +44 (0)1872 223306

EasyDAQ

www.easydaq.biz

We design & supply low cost USB/RS232 based data acquisition, automation & control products:

- USB connected & powered, 8 opto isolated voltage inputs chans, 4DIO & 4 onboard relays capable of switching 240V@10A. With Labview, VC & VB examples - £60



EASYSYNC

<http://www.easysync.co.uk>

EasySync Ltd sells a wide range of single and multi-port USB to RS232/RS422 and RS485 converters at competitive prices.



ELNEC

www.elnec.com

- device programmer manufacturer
- selling through contracted distributors all over the world
- universal and dedicated device programmers
- excellent support and after sale support
- free SW updates
- reliable HW
- once a months new SW release
- three years warranty for most programmers



FIRST TECHNOLOGY TRANSFER LTD.

<http://www.ftt.co.uk/PICProTrng.html>

Microchip Professional C and Assembly Programming Courses. The future is embedded. Microchip Consultant / Training Partner developed courses:



- Distance learning / instructor led
- Assembly / C-Programming of PIC16, PIC18, PIC24, dsPIC microcontrollers
- Foundation / Intermediate

FLEXIPANEL LTD

www.flexipanel.com

TEAclippers - the smallest PIC programmers in the world, from £20 each:

- Per-copy firmware sales
- Firmware programming & archiving
- In-the-field firmware updates
- Protection from design theft by subcontractors



FUTURE TECHNOLOGY DEVICES

<http://www.ftdichip.com>

FTDI designs and sells USB-UART and USB-FIFO interface i.c.'s.

Complete with PC drivers, these devices simplify the task of designing or upgrading peripherals to USB



FUTURLEC

<http://www.futurlec.com>

Save up to 60% on

- Electronic Components
 - Microcontrollers, PIC, Atmel
 - Development Boards, Programmers
- Huge range of products available on-line for immediate delivery, at very competitive prices.



ILP ELECTRONICS LTD

www.ilpelectronics.com

Tel +441233750481

Fax +441233750578

ILP have been manufacturing audio modules since 1971 and apart from our standard range we also offer a custom design service for the OEM market.



LONDON ELECTRONICS COLLEGE

<http://www.lec.org.uk>

Vocational training and education for national qualifications in Electronics Engineering and Information Technology (BTEC First National, Higher National NVQs, GCSEs and Advanced Qualifications). Also Technical Management and Languages.

MARCHAND ELECTRONICS INC.

www.marchandelec.com

- power amplifier modules
- electronic crossovers solid state / valve / passive
- valve amplifiers
- phono preamps
- handheld sinewave generator
- kits or assembled
- software electronic instruments
- custom design services



products and services directory

MQP ELECTRONICS

www.mqp.com

- Low cost USB Bus Analysers
- High, Full or Low speed captures
- Graphical analysis and filtering
- Automatic speed detection
- Bus powered from high speed PC
- Capture buttons and feature connector
- Optional analysis classes



ROBOTIQ

<http://www.robotiq.co.uk>

Build your own Robot!
Fun for the whole family!

- Meccano™ Compatible
- Computer Control
- Radio Control
- Tank Treads
- Hydraulics

Internet Technical Bookshop,
1-3 Fairlands House, North Street, Carshalton,
Surrey SM5 2HW
email: sales@robotiq.co.uk Tel: 020 8669 0769



USB INSTRUMENTS

<http://www.usb-instruments.com>

USB Instruments specialises in PC based instrumentation products and software such as Oscilloscopes, Data Loggers, Logic Analysers which interface to your PC via USB.



NEW WAVE CONCEPTS

www.new-wave-concepts.com

Software for Hobbyists:

- Livewire - circuit simulation software, only £34.99
- PCB Wizard - PCB design software, only £34.99
- Circuit Wizard - circuit, PCB and breadboard design software, only £59.99

Available from all Maplin Electronics stores and www.maplin.co.uk



COMPONENTBIN.COM

www.componentbin.com

Kickstart your development with modules and parts from componentbin.com

- ARM7 modules
- Ethernet modules
- Superb Graphic LCD displays (all with example software)

and much much more...
Online ordering and great prices!



VIRTINS TECHNOLOGY

www.virtins.com

PC and Pocket PC based virtual instrument such as sound card real time oscilloscope, spectrum analyzer, signal generator, multimeter, sound meter, distortion analyzer, LCR meter. Free to download and try.



ROBOT ELECTRONICS

<http://www.robot-electronics.co.uk>

Advanced Sensors and Electronics for Robotics

- Ultrasonic Range Finders
- Compass modules
- Infra-Red Thermal sensors
- Motor Controllers
- Vision Systems
- Wireless Telemetry Links
- Embedded Controllers



ULTRALEDS

[Ultraleds.co.uk](http://www.ultraleds.co.uk)

<http://www.ultraleds.co.uk>

tel: 0871 7110413 / 01625 576778
Large range of low cost Ultra bright leds and Led related lighting products. Major credit cards taken online with same day depatch.

www.elektor.com

SHOWCASE YOUR COMPANY HERE

Elektor Electronics has a feature to help customers promote their business, Showcase - a permanent feature of the magazine where you will be able to showcase your products and services.

- For just £220 + VAT (£20 per issue for eleven issues) Elektor will publish your company name, website address and a 30-word description
- For £330 + VAT for the year (£30 per issue for eleven issues) we will publish the above plus run a 3cm deep full colour

image - e.g. a product shot, a screen shot from your site, a company logo - your choice

Places are limited and spaces will go on a strictly first come, first served basis. So-please fax back your order today!

I wish to promote my company, please book my space:

- Text insertion only for £220 + VAT
- Text and photo for £330 + VAT

NAME: ORGANISATION:

JOB TITLE:

ADDRESS:

TEL:

PLEASE COMPLETE COUPON BELOW AND FAX BACK TO 00-44-(0)1932 564998

COMPANY NAME

WEB ADDRESS

30-WORD DESCRIPTION

.....

.....

.....

.....

.....

.....

.....

.....

.....

.....

Going Strong

A world of electronics from a single shop!



ElekTrack

(October 2007)

Position determination is all the rage. The alarm systems of expensive cars and other vehicles often comprise positioning systems so they can report where the vehicle is located. However, such systems are rather expensive, so we decided to take the DIY approach and develop our own version, dubbed ElekTrack. Due to the large number of SMD components and the difficulty of soldering such components, we decided to supply this module fully assembled only.

PCB, ready assembled and tested, GPS/GSM-antenna, cable and case

Art.# 040161-91 • £275.00 • US\$ 550.00

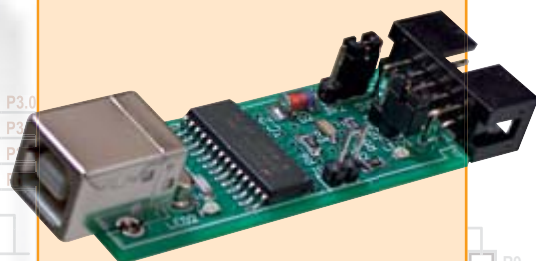

USBprog

(October 2007)

A new microcontroller, and yet another new programmer? Anyone involved with microcontrollers today will have a drawerful of printed circuit boards and adaptors for programming various devices. Enter USBprog, which can replace all those with a single unit. As a bonus, it can even be used as a generalpurpose USB I/O port and RS-232 adaptor.

PCB, SMD populated plus other parts

Art. # 060224-71 • £18.80 • US\$ 37.60



An 8051-based system for rapid software development

USB Flash Board

Flash microcontrollers are easy to program. In the past, program code was usually downloaded via a serial interface, but nowadays many PCs (especially laptops) only have USB ports. This versatile Flash Board provides a solution to this problem. It is built around an AT89C5131A, which is an extended 8051-family microcontroller with an 80C52 core and a Full Speed USB port. As a sort of bonus, the IC has a complete update interface for downloading new firmware. Atmel also provides suitable software in the form of its FLIP program, which is available free of charge.

Construction kit including the PCB and all parts

Art. # 070125-71 • £36.20 • US\$ 72.40



5.0, 6.0, VBA, .NET, 2005

Visual Basic for Electronics Engineering Applications

This book is targeted towards those people that want to control existing or self-built hardware from their computer. After familiarizing yourself with Visual Basic, its development environment and the tool-set it offers are discussed in detail. Each topic is accompanied by clear, ready to run code, and where necessary, schematics are provided that will get your projects up to speed in no time.

476 pages • ISBN 978-0-905705-68-2
£29.00 • US\$ 58.00



Bestseller!

Fully elaborated electronics projects

309 Circuits

The present tenth edition of the popular '30x Circuits' series of books once again contains a comprehensive variety of circuits, sub-circuits, tips and tricks and design ideas for electronics. Among many other inspiring topics, the following categories are well presented in this book: test & measurement; RF (radio); computers and peripherals; audio & video; hobby and modelling; microcontrollers; home & garden; etcetera.

432 pages • ISBN 978-0-905705-69-9
£19.95 • US\$ 39.95



NEW!

More than 68,000 components

Elektor's Components Database 4

The program package consists of eight databanks covering ICs, germanium and silicon transistors, FETs, diodes, thyristors, triacs and optocouplers. A further eleven applications cover the calculation of, for example, LED series droppers, zener diode series resistors, voltage regulators and AMVs. A colour band decoder is included for determining resistor and inductor values. ECD 4 gives instant access to data on more than 68,000 components. All databank applications are fully interactive, allowing the user to add, edit and complete component data. This CD-ROM is a must-have for all electronics enthusiasts.

ISBN 978-90-5381-159-7 • £15.90 • US\$ 31.80



Bestseller!

Software Tools & Hardware Tips

Ethernet Toolbox

This CD-ROM contains all essential information regarding Ethernet interfaces! Ethernet Toolbox includes a collection of datasheets for dedicated Ethernet interface ICs from many different manufacturers. To help you with your own projects, the CD-ROM provides a wealth of information about connectors and components for the physical layer (PHY) and specific software tools for use with the Ethernet (Software). To help you learn about the Ethernet interfaces, we have compiled a collection of all articles on this topic that have appeared in Elektor and complemented them with additional documentation and links to introductory articles on Ethernet interfaces. All of the documents are PDF files.

ISBN 978-90-5381-214-3 • £18.90 • US\$ 37.90



Embedded USB Know How

USB Toolbox

This CD-ROM contains all the essential information a designer needs to start working with the USB interface. It includes a large collection of datasheets for specific USB components from a wide range of manufacturers. USB Toolbox provides information on all ICs suitable for different applications. A sub-division has been made in controllers, hubs, microcontrollers and others.

ISBN 978-90-5381-212-9 • £19.90 • US\$ 39.80

More information on the brand new Elektor Website:
www.elektor.com

Elektor
Regus Brentford
1000 Great West Road
Brentford TW8 9HH
United Kingdom
Tel.: +44 20 8261 4509
Fax: +44 20 8261 4447
Email: sales@elektor.com

elektor
SHOP

December 2007 (No. 372)

£ US\$

+ + + Product Shortlist December: See www.elektor.com + + +

November 2007 (No. 371)

USB Data Acquisition Card

070148-1	PCB, bare	9.50	19.00
070148-41	PIC18F4550 DIP40, programmed	15.50	31.00
070148-81	Software on CD-ROM	5.20	10.40

Line Switcher

060288-1	PCB, bare	www.thePCBshop.com	
----------	-----------	------------------------------------------------------------	--

Headphone Amp with 3D Sound

070393-1	PCB, bare	www.thePCBshop.com	
----------	-----------	------------------------------------------------------------	--

Low-cost Heating Controller

060325-1	Printed circuit board	9.60	19.20
060325-41	Programmed controller ATmega32-16PU	15.80	31.60

USB Flash Board

070125-1	PCB, bare	17.90	35.80
070125-71	Kit of parts, PCB and all parts	36.20	72.40
070125-81	Software on CD-ROM	5.20	10.40

October 2007 (No. 370)

ElekTrack

040161-91	PCB, ready assembled and tested, GPS/GSM-antenna, cable and case	275.00	550.00
-----------	---------------------------------------------------------------------	--------	--------

USBprog

060224-1	Printed circuit board	www.thePCBshop.com	
060224-71	PCB, SMD populated plus other parts	18.80	37.80
060224-81	Software on CD-ROM	5.20	10.40

Mugen: A Hybrid Audio Amplifier

070069-1	Printed circuit board, amplifier (mono)	20.70	41.40
070069-2	Printed circuit board, power supply	19.30	38.60

September 2007 (No. 369)

Tilt Gamepad

070233-41	Programmed controller ATmega8-16PI	6.20	12.35
070233-81	Software on CD-ROM	5.20	10.40
070233-91	Printed circuit board with sensor fitted	18.90	37.80

Digital Inspector

060092-1	Printed circuit board	www.thePCBshop.com	
060092-41	Programmed controller PIC18F4580-I/P	13.10	26.20
060092-71	Kit of parts PCB, controller, case and all parts	77.60	155.20
060092-81	Software on CD-ROM	5.20	10.40

July/August 2007 (No. 367)

Dual Battery

070343-1	PCB, bare	5.20	9.75
----------	-----------	------	------

Fast Charger for NiMH Batteries

070213-1	PCB, bare	www.thePCBshop.com	
----------	-----------	------------------------------------------------------------	--

Lithium Charger

070273-1	PCB, bare	8.90	12.95
----------	-----------	------	-------

Low2 Cost USB Demo Board

060342-81	CD-ROM, project software	5.20	9.75
060342-41	PIC18F4550, programmed	15.15	28.50

LPC 900 Programmer

070084-1	PCB, bare	6.90	12.95
----------	-----------	------	-------

MotoBox

070129-1	PCB, bare	www.thePCBshop.com	
070129-41	PIC16F628-04/P, programmed	14.80	27.95

Propeller Prototyping Board for BoeBot

070275-1	PCB, bare	11.00	20.75
----------	-----------	-------	-------

Satnav for Robots

070350-81	CD-ROM, project software	5.20	9.75
070350-41	ATmega32, programmed	16.50	31.15

Serial Interface for the Propeller

070276-1	PCB, bare	www.thePCBshop.com	
----------	-----------	------------------------------------------------------------	--

Stereo Robot Ears

060040-1	PCB, bare	www.thePCBshop.com	
060040-81	CD-ROM, project software	5.20	9.75
060040-41	PIC16F88, programmed	10.00	18.85

Bestsellers

Books

- ➔ **309 Circuits**
ISBN 978-0-905705-69-9 £19.95 US\$ 39.95
- ➔ **Visual Basic** for Electronics Engineering Applications
ISBN 978-0-905705-68-2 £29.00 US\$ 58.00
- ➔ **Microcontroller Basics**
ISBN 978-0-905705-67-5 £19.50 US\$ 39.00
- ➔ **PC Interfaces under Windows**
ISBN 978-0-905705-65-1 £27.25 US\$ 54.50
- ➔ **Designing Audio Circuits**
ISBN 978-0-905705-50-7 £20.75 US\$ 41.50

CD-ROMs

- ⬆ **ECD4**
ISBN 978-90-5381-159-7 £15.90 US\$ 31.80
- ⬆ **Ethernet Toolbox**
ISBN 978-90-5381-214-3 £18.90 US\$ 37.90
- ⬆ **USB Toolbox**
ISBN 978-90-5381-212-9 £19.90 US\$ 39.80
- ⬆ **Home Automation**
ISBN 978-90-5381-195-5 £13.90 US\$ 27.80
- ⬆ **Elektor 2006**
ISBN 978-90-5381-207-5 £16.90 US\$ 33.80

Kits & Modules

- ⬆ **USB Flash Board**
Art. # 070125-71 £36.20 US\$ 72.40
- ⬆ **Stand Alone OBD-2 Analyser**
Art. # 070038-72 £55.20 US\$ 110.40
- ➔ **ElekTrack**
Art.# 040161-91 £275.00 US\$ 550.00
- ⬆ **USBprog**
Art. # 060224-71 £18.80 US\$ 37.60
- ⬆ **Digital Inspector**
Art. # 060092-71 £77.60 US\$ 155.20

Order online at
www.elektor.com

or use the Order Form near the end
of the magazine!

elektor
SHOP

Elektor
Regus Brentford
1000 Great West Road
Brentford TW8 9HH • United Kingdom
Tel. +44 20 8261 4509
Fax +44 20 8261 4447
Email: sales@elektor.com

Things of the past.

Elektor is now & tomorrow.

Secure a head start in electronics with a subscription!

Advantages to subscribers:

- ✓ Cheaper than 11 issues from the newsstand
- ✓ Subscribers get up to **40% discount** on special Elektor products
- ✓ As a welcome gift you get a free **1GB MP3 player** worth £ 34.50
- ✓ No queues, travelling, parking fees or 'sold out' Elektor is supplied to your doorstep every month
- ✓ Always up to date – read your copy before everyone else



FREE 3-in-1 welcome gift: 1GB MP3 player, USB Stick and Voice Recorder

www.elektor.com/subs
Tel. +44 (0) 20 8261 4509

Or use the subscription order form near the end of the magazine.

elektor
electronics worldwide

CO₂-sensor

The air quality in homes and offices is an important factor that's often neglected. As you breathe and exhale, the oxygen contained in air is converted into carbon dioxide (not carbon monoxide, which is highly poisonous). Although a too high CO₂ level in the air is not dangerous, it does cause effects like fatigue and reduced concentration — just watch what happens during long meetings! The Elektor CO₂ sensor allows carbon dioxide levels to be monitored in an easy way. In addition it supplies a warning at excessive levels, or switches on an air circulation system.



Energy Meters

January's Elektor is all about energy savings and for that it's useful to know just how much power all that electrical kit in your home or office is consuming. We do a survey of plug-in energy meters on the market today to see if the watts values they show are any good.

Versatile DC Power Meter

Lots of DC power supplies have no indication for the current or voltage at the output. Our compact add-on board overcomes this shortage using an LCD for the readout. On it you can see the I and V values as numbers or a bargraph, but that's not all — the unit also does Ah and kWh measurements for you!



RESERVE YOUR COPY NOW!

UK mainland subscribers will receive the magazine between 15 and 18 December 2007.

The January 2008 issue goes on sale on Thursday 20 December 2007 (UK distribution only).

Article titles and magazine contents subject to change, please check www.elektor.com.

NEWSAGENTS ORDER FORM

SHOP SAVE / HOME DELIVERY

Please save / deliver one copy of *Elektor* magazine for me each month

Name:

Address:

Post code:

Telephone:

Date:

Signature:



Please cut out or photocopy this form, complete details and hand to your newsagent.
 Elektor is published on the third Thursday of each month, except in July.
 Distribution S.O.R. by Seymour (NS).

www.elektor.com www.elektor.com www.elektor.com www.elektor.com www.elektor.com

Elektor on the web

All magazine articles back to volume 2000 are available online in pdf format. The article summary and parts list (if applicable) can be instantly viewed to help you positively identify an article. Article related items are also shown, including software downloads, circuit boards, programmed ICs and corrections and updates if applicable. Complete magazine issues may also be downloaded.

In the Elektor Shop you'll find all other products sold by the publishers, like CD-ROMs, kits and books. A powerful search function allows you to search for items and references across the entire website.

Also on the Elektor website:

- Electronics news and Elektor announcements
- Readers Forum
- PCB, software and e-magazine downloads
- Surveys and polls
- FAQ, Author Guidelines and Contact



ORDERING INSTRUCTIONS, P&P CHARGES

Except in the USA and Canada, all orders, except for subscriptions (for which see below), must be sent BY POST or FAX to our Brentford address using the Order Form overleaf. Online ordering: www.elektor.com/shop

Readers in the USA and Canada may (but are not obliged to) send orders, except for subscriptions (for which see below), to the USA address given on the order form. Please apply to Old Colony Sound for applicable P&P charges. Please allow 4-6 weeks for delivery.

Orders placed on our Brentford office must include P&P charges (Priority or Standard) as follows: Europe: £6.00 (Standard) or £7.00 (Priority) Outside Europe: £9.00 (Standard) or £11.00 (Priority)

HOW TO PAY

All orders must be accompanied by the full payment, including postage and packing charges as stated above or advised by Customer Services staff.

Bank transfer into account no. 40209520 held by Elektor Electronics with ABN-AMRO Bank, London. IBAN: GB35 ABNA 4050 3040 2095 20. BIC: ABNAGB2L. Currency: sterling (UKP). Please ensure your full name and address gets communicated to us.

Cheque sent by post, made payable to Elektor Electronics. We can only accept sterling cheques and bank drafts from UK-resident customers or subscribers. We regret that no cheques can be accepted from customers or subscribers in any other country.

Giro transfer into account no. 34-152-3801, held by Elektor Electronics. Please do not send giro transfer/deposit forms directly to us, but instead use the National Giro postage paid envelope and send it to your National Giro Centre.

Credit card VISA and MasterCard can be processed by mail, email, web, fax and telephone. Online ordering through our website is SSL-protected for your security.

COMPONENTS

Components for projects appearing in Elektor are usually available from certain advertisers in this magazine. If difficulties in the supply of components are envisaged, a source will normally be advised in the article. Note, however, that the source(s) given is (are) not exclusive.

TERMS OF BUSINESS

Delivery Although every effort will be made to dispatch your order within 2-3 weeks from receipt of your instructions, we can not guarantee this time scale for all orders. **Returns** Faulty goods or goods sent in error may be returned for replacement or refund, but not before obtaining our consent. All goods returned should be packed securely in a padded bag or box, enclosing a covering letter stating the dispatch note number.

If the goods are returned because of a mistake on our part, we will refund the return postage. **Damaged goods** Claims for damaged goods must be received at our Brentford office within 10-days (UK); 14-days (Europe) or 21-days (all other countries). **Cancelled orders** All cancelled orders will be subject to a 10% handling charge with a minimum charge of £5.00. **Patents** Patent protection may exist in respect of circuits, devices, components, and so on, described in our books and magazines. Elektor does not accept responsibility or liability for failing to identify such patent or other protection. **Copyright** All drawings, photographs, articles, printed circuit boards, programmed integrated circuits, diskettes and software carriers published in our books and magazines (other than in third-party advertisements) are copyright and may not be reproduced or transmitted in any form or by any means, including photocopying and recording, in whole or in part, without the prior permission of Elektor in writing. Such written permission must also be obtained before any part of these publications is stored in a retrieval system of any nature.

Notwithstanding the above, printed-circuit boards may be produced for private and personal use without prior permission. **Limitation of liability** Elektor shall not be liable in contract, tort, or otherwise, for any loss or damage suffered by the purchaser whatsoever or howsoever arising out of, or in connexion with, the supply of goods or services by Elektor other than to supply goods as described or, at the option of Elektor, to refund the purchaser any money paid in respect of the goods. **Law** Any question relating to the supply of goods and services by Elektor shall be determined in all respects by the laws of England.

September 2007

SUBSCRIPTION RATES FOR ANNUAL SUBSCRIPTION

	Standard	Plus
United Kingdom	£41.90	£48.80
Surface Mail		
Rest of the World	£54.50	£61.40
USA & Canada	US\$ 95.50	US\$106.50
Airmail		
Rest of the World	£68.90	£75.80
USA & Canada	US\$120.00	US\$131.00

HOW TO PAY

Bank transfer into account no. 40209520 held by Elektor Electronics with ABN-AMRO Bank, London. IBAN: GB35 ABNA 4050 3040 2095 20. BIC: ABNAGB2L. Currency: sterling (UKP). Please ensure your full name and address gets communicated to us.

Cheque sent by post, made payable to Elektor Electronics. We can only accept sterling cheques and bank drafts from UK-resident customers or subscribers. We regret that no cheques can be accepted from customers or subscribers in any other country.

Giro transfer into account no. 34-152-3801, held by Elektor Electronics. Please do not send giro transfer/deposit forms directly to us, but instead use the National Giro postage paid envelope and send it to your National Giro Centre.

Credit card VISA and MasterCard can be processed by mail, email, web, fax and telephone. Online ordering through our website is SSL-protected for your security.

SUBSCRIPTION CONDITIONS

The standard subscription order period is twelve months. If a permanent change of address during the subscription period means that copies have to be despatched by a more expensive service, no extra charge will be made. Conversely, no refund will be made, nor expiry date extended, if a change of address allows the use of a cheaper service.

Student applications, which qualify for a 20% (twenty per cent) reduction in current rates, must be supported by evidence of student-ship signed by the head of the college, school or university faculty. A standard Student Subscription costs £33.50, a Student Subscription-Plus costs £40.40 (UK only).

Please note that new subscriptions take about four weeks from receipt of order to become effective.

Cancelled subscriptions will be subject to a charge of 25% (twenty-five per cent) of the full subscription price or £7.50, whichever is the higher, plus the cost of any issues already dispatched. Subscriptions cannot be cancelled after they have run for six months or more.

January 2007

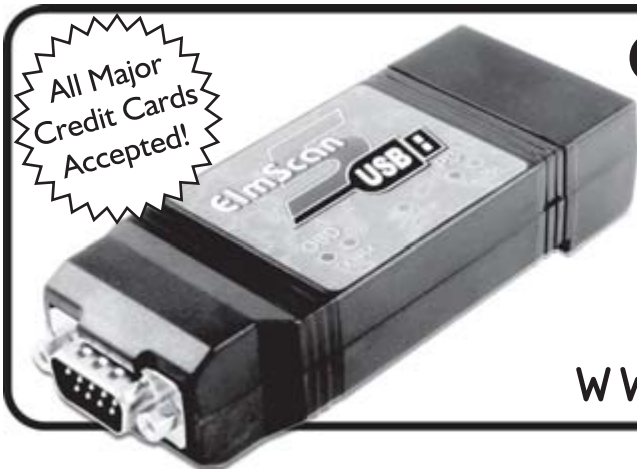

ElmScan 5 USB Scan Tool

- Diagnose any car with EOBD
- Based on the ELM327 IC
- Supports all EOBD and OBD-II protocols
 - ✓ ISO15765-4 (CAN)
 - ✓ ISO14230-4 (Keyword 2000)
 - ✓ ISO9141-2
 - ✓ J1850 VPW
 - ✓ J1850 PWM
- 9600 or 38400 baud
- Supported by more software than any other OBD interface
- Inexpensive
- Full Speed USB 1.1
- Automatic protocol detection
- Package includes cables, software CD, and Quick Start Guide
- Buy from your local UK distributors!

www.ElmScan5.com/elektor

Your price conscious PCB supplier



Online price calculation
Online ordering
Online order tracking
Online 24/24H and 7/7D

Interested? Contact us: +44 2088 167 005
E-mail: euro@eurocircuits.com
www.eurocircuits.com

- Verified**
 - pooling for standard boards
 - up to 6 layers
 - from 1 to 1000 pieces
 - from 3 working days onwards
- A la carte**
 - pooling with more options
 - up to 8 layers
 - from 1 to 1000 pieces
 - from 3 working days onwards
- On demand**
 - your board, our challenge
 - up to 16 layers
 - from 1 piece onwards
 - from 3 working days onwards

INDEX OF ADVERTISERS

Antex Electronics Ltd	www.antex.co.uk	45	Mikro Elektronika	www.mikroe.com	14, 15
Allendale Electronics Ltd	www.pcb-soldering.co.uk	29	MQP Electronics, Showcase	www.mqp.com	103
Antex Electronics Ltd	www.antex.co.uk	29	New Wave Concepts, Showcase	www.new-wave-concepts.com	103
ATC Semitec Ltd,	Showcase www.atcsemitec.co.uk	102	Newbury Electronics	www.newburyelectronics.co.uk	79
Audio Amateur	www.audioXpress.com	79	Number One Systems	www.numberone.com	79
Avit Research, Showcase	www.avitresearch.co.uk	102	Nurve Networks	www.xgamestation.com	69
Beijing Draco	www.ezpcb.com	89	Paltronix	www.paltronix.com	39
Beta Layout, Showcase	www.pcb-pool.com	79, 102	SK Pang Electronics	www.skpang.co.uk	89
Bitscope Designs	www.bitscope.com	3	Peak Electronic Design	www.peakelec.co.uk	69
Bowood Electronics Ltd, Showcase	www.bowood-electronics.co.uk	102	Pico	www.picotech.com	75
Byvac Electronics, Showcase	www.byvac.co.uk	102	Quasar Electronics	www.quasarelectronics.com	99
Cleverscope	www.cleverscope.com	69	Robot Electronics, Showcase	www.robot-electronics.co.uk	103
Decibit Co. Ltd, Showcase	www.decibit.com	102	Robotiq, Showcase	www.robotiq.co.uk	103
Designer Systems, Showcase	www.designersystems.co.uk	102	Scantool	www.ElmScan5.com/elektor	111
EasyDAQ, Showcase	www.easydaq.biz	102	Schaeffer AG	www.schaeffer-ag.de	89
Easysync, Showcase	www.easysync.co.uk	102	Showcase	102, 103
Eltec, Showcase	www.eltec.com	102	Tsien (UK) Ltd, Showcase	www.componentbin.com	89, 83
Eurocircuits	www.eurocircuits.com	111	Ultraleds, Showcase	www.ultraleds.co.uk	103
First Technology Transfer Ltd, Showcase	www.ftt.co.uk	69, 102	USB Instruments, Showcase	www.usb-instruments.com	103
FlexiPanel Ltd, Showcase	www.flexipanel.com	102	Velleman	www.velleman.be	i-TRIXX backcover
Future Technology Devices, Showcase	www.ftdichip.com	102	Virtins Technology, Showcase	www.virtins.com	103
Futurlec, Showcase	www.futurlec.com	102			
ILP Electronics Ltd, Showcase	www.ilpelectronics.com	102			
Jaycar Electronics	www.jaycarelectronics.co.uk	2			
Labcenter	www.labcenter.com	112			
London Electronics College, Showcase	www.lec.org.uk	102			
Marchand Electronics Inc, Showcase	www.marchandelec.com	102			

**Advertising space for the issue of 21 January 2008
may be reserved not later than 21 December 2007**

with Huson International Media – Cambridge House – Gogmore Lane – Chertsey, Surrey KT16 9AP – England – Telephone 01932 564 999 – Fax 01932 564998 – e-mail: gerryb@husonmedia.com to whom all correspondence, copy instructions and artwork should be addressed.

PROTEUS

DESIGN SUITE

COMPUTER ~~AIDED~~ DESIGN ENHANCED

- Powerful, Easy to Use Schematic Capture
- Interactive Mixed Mode SPICE Simulation
- Unique Microcontroller Co-Simulation and Debugging
- Fully Featured PCB Design and 3D Viewer

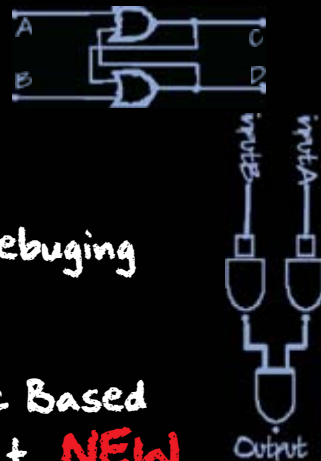

+

Worlds First Schematic Based
USB Simulation Product **NEW**

=

- Complete Engineering Solution
- Rapid Development Environment
- Maximum Return on Investment
- Faster Time to Market



AUTUMN SPECIAL OFFER

20% off all new orders for the Proteus Design Suite when you spend £400 or more.

Electronic Design from Concept To Completion

LABCENTER ELECTRONICS LTD

A technology Pioneer in the EDA industry since 1988.
Technical support direct from the program authors.
Flexible packages and pricing tailored to customer requirements.

CONTACT US NOW

to discuss your requirements or
request a FREE evaluation copy.

labcenter  www.labcenter.com
Electronics

TEL: +44 (0)1756 753440
FAX: +44 (0)1756 752857
Email: info@labcenter.com

Labcenter Electronics Ltd., 53-55 Main Street, Grassington
North Yorks, BD23 5AA. Registered in England 4692454