

Forget your password

Fingerprint sensors

Improving security:

- PC Data Authentication
- Flash Lock for PCs
- TIRIS RFID Reader



Biometrical Identification



27C512 Emulator

design with a perspective



This is where we live!

Jaycar Electronics

Yes that's right, down town, down under in Sydney Australia. We are a bunch of electronics enthusiasts who sell a great range of goodies through our FREE 400 page catalogue! (see below) Don't be frightened! You can purchase on the Net from us 24/7/365 through our secure encrypted system. Post and packing charges are modest and you can have any of 8000 + unique products delivered to your door within 7 - 10 days of your order. Some specific products are shown below.

Theremin Synthesiser Kit

KC-5295 £17.50 + post & packing

The Theremin is a weird musical instrument that was invented early last century but is still used today. The Beach Boys' classic hit "Good Vibrations" featured a Theremin. By moving your hand between the antenna and metal plate, you create weird sound effects like in those scary movies!

Kit includes a machined, silk-screened, and pre drilled case, circuit board, all electronic components, and clear English instructions.



9VDC power supply required (Maplin #GS74R £9.99).

50MHz Frequency Meter Kit with LCD Display

KC-5369 £20.30 + post & packing

If you want a great value frequency meter, then this project is for you. It features autoranging operation for ease of use, switching between its three ranges. High resolution of 0.1Hz up to 150Hz, 1Hz between 150Hz and 16MHz, and 10Hz above 16MHz. It can be powered by a 9V battery or wall adaptor (not included) and the case measures just 5 1/8" x 2 5/8" x 1". Kit includes laser cut & silk screened case, circuit board, electronic components, & clear English instructions.



Performance Electronics for Cars Book

BS-5080 £6.35 + post & packing

Australia's leading electronics magazine, Silicon Chip, has developed a range of projects for performance cars. There are 16 projects in total, ranging from devices for remapping fuel curves, to nitrous controllers, and more! The book includes all instructions, components lists, colour pictures, and circuit layouts. There are also chapters on engine management, advanced systems, DIY modifications, and more. Over 150 pages! All of the projects described are available in kit form, exclusively from Jaycar. Check out our website for all the details.

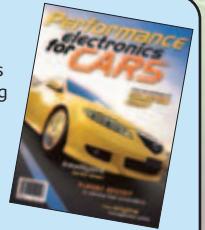

Here are just two....

Universal Voltage Switch Kit

KC-5377 £8.70 + post and packing

This is a universal module which can be adapted to suit a range of different applications. It will trip a relay when a preset voltage is reached. It can be configured to trip with a rising or falling voltage, so it is suitable for a wide variety of voltage outputting devices eg., throttle position sensor, air flow sensor, EGO sensor. It also features adjustable hysteresis (the difference between trigger on/off voltage), making it extremely versatile. You could use it to trigger an extra fuel pump under high boost, anti-lag wastegate shutoff, and much more. Kit supplied with PCB, and all electronic components.



Recommended box UB2 £0.97 each

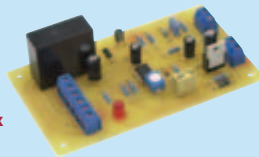

Recommended box UB3 £0.97 each

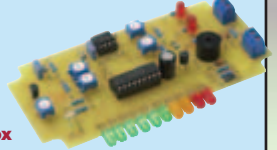

Smart Fuel Mixture Display

KC-5374 £8.15 + post & packing

This new 'smart' version has a few additional touches such as, auto dimming for night driving, emergency lean-out alarm, and better circuit protection. Another great feature, is the 'dancing' display which operates when the ECU is operating in closed loop. Closed loop means that the air/fuel ratio is optimum for fuel economy and emission performance. Kit supplied with PCB and all electronic components.

• Car must be fitted with air flow and EGO sensors (standard on all EFI systems) for full functionality.

Digital Fuel Mixture Display

KC-5300 £18.30 + post and packaging

Monitor your car's air fuel ratio in real time on a three-digit display as well as on the programmable 10-LED bargraph. The kit will indicate ratios between 11.8 & 20.6 for petrol and 12.7 & 21.5 for propane/LPG. Features include: lean and rich indication, fast 220ms update time for bargraph, 440ms update time for 3-digit display, 0-1V display for setting up adjustments, dot or bar option for bargraph and automatic display dimming for night driving. All this in a case measuring just 3.25 x 2.12 x 1.22 in. Kit includes case with silk-screened panel, PCBs, pre-programmed PIC micro, 7-segment displays, red acrylic, hook-up wire and all electronic components.

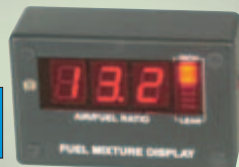

We Stock...

Electronic Components, Sub-Assemblies & Electronic Kits

Power Products & Accessories

Audio & Visual Equipment & Accessories

Computer & Telecoms Accessories

Burglar Alarms & Surveillance Equipment

Lighting Products & Accessories

Gadgets & Unique Gifts

Lead Acid Battery Zapper Kit

KC-5414 £11.75 + post and packing

This simple circuit is designed to produce bursts of high-energy pulses to help reverse the effects of sulfation in "wet" lead acid batteries. This is particularly useful when the battery has been sitting for a period of time without use. Kit includes circuit board, case, leads, electronic components, and clear English instructions.



NEW KIT



Caution: Battery should be disconnected from the vehicle when using this project



400+ page Catalogue

Post and Packing Charges:

Order Value	Cost
£20 - £49.99	£5
£50 - £99.99	£10
£100 - £199.99	£20
£200 - £499.99	£30
£500+	£40

Max weight 12lb (5kg) - heavier parcels POA. Minimum order £20.

Log on to www.jaycarelectronics.co.uk/elektor for your FREE catalogue!

0800 032 7241

(Monday - Friday 09.00 to 17.30 GMT + 10 hours only).

For those who want to write:

100 Silverwater Rd Silverwater NSW 2128 Sydney AUSTRALIA

MikroElektronika

MICROCONTROLLER DEVELOPMENT TOOLS

from Breadboarding Systems

Make PICmicro[®] development easy with the EasyPIC3 - *only £99!*

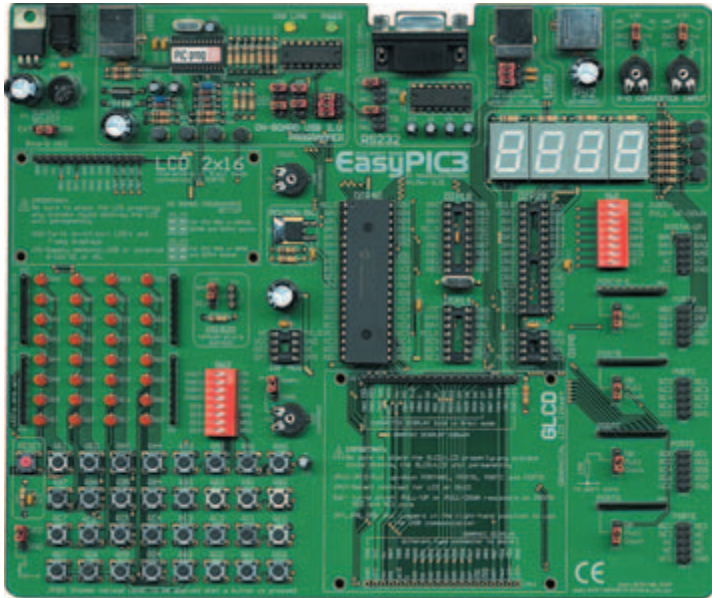

The new EasyPIC3 Development Board combines a versatile development/experiment board with a built-in USB programmer. With its wealth of on-board I/O devices and support for virtually all 8, 14, 18, 28 and 40-pin PICmicro[®] microcontrollers in the 10F, 12F, 16F and 18F families, we're certain you won't find a more versatile high quality board at such a low price. The EasyPIC3 Development Board is supplied with USB programming/power cable, programming software and useful example programs.

Also available are similar boards for the 8051, AVR and dsPIC, each at the same great price of £99 including UK delivery and VAT—please telephone or see our website for further details.

EasyPIC3 Development Board features:

- High quality development/experiment board with built-in USB 2.0 high-speed programmer.
- Programming software compatible with Windows operating systems including 2000 and XP.
- Comes with a PIC16F877A microcontroller but compatible with virtually all 8, 14, 18, 28 and 40-pin PICmicro[®] devices in the 10F, 12F, 16F and 18F families.
- On-board I/O devices including switches, LEDs, seven-segment displays, potentiometers and RS-232 interface. Now also features USB and PS/2 keyboard interface connectors.
- Provision for easy fitting of optional DS18S20 temperature sensor, and LCD and GLCD displays.
- All I/O lines available for off-board expansion.
- Wide range of optional add-on boards available including ADC, DAC, EEPROM, Compact Flash, MMC/SD, Keypad, RTC, RS-485, CAN and IrDA. Additional add-ons available soon.
- Powered from your PC's USB port or optional mains adapter.
- Supplied with example programs written in assembly language, BASIC, C and Pascal.
- Supplied with Microchip Technology's MPLAB development software and demonstration versions of MikroElektronika's mikroBASIC, mikroC and mikroPascal compilers.

Learn about microcontrollers with our EasyPIC3 Starter Pack - *just £149!*

We've taken the EasyPIC3 Development Board and added a 16x2 character LCD display, 128x64 graphical LCD, DS18S20 temperature sensor, RS-232 serial communications cable and our own easy-to-follow microcontroller tutorial to form a complete and self-contained Starter Pack—everything you need to learn about and experiment with microcontrollers! With this pack you will quickly become proficient in microcontroller programming and interfacing. Please see our website for full list of covered topics.

Make programming easy too with mikroBASIC, mikroC and mikroPascal

Three incredibly easy-to-use yet powerful compilers for PICmicro[®] microcontrollers, each featuring a user-friendly code editor, built-in tools and routines and source-level debugger. Supplied libraries facilitate rapid development and include ADC, CAN, Compact Flash, EEPROM, Ethernet, Graphic LCD, I²C, LCD, 1-wire, PWM, RS-485, sound, SPI, USART, USB routines and many more. mikroBASIC and mikroPascal—£99 each, mikroC—£149.

Call 0845 226 9451 or order online at www.breadboarding.co.uk

All prices include UK delivery and VAT. Major credit and debit cards accepted. Secure online ordering.

Input threshold: (almost) zero

For some mysterious reason we get emails from readers timidly asking if they can contribute to the magazine. The answer is almost invariably, Yes, we will only be too pleased to have a look at what you are proposing in the way of an article, be it a construction project, a news item or a background story. Our *Author Guidelines* may be found on the *Service* page of our website and the word is out that we pay between 60 and 100 pounds per published page depending on the amount of re-engineering or editorial work. In the case of projects, once your proposal has been accepted for publication (and that may take us quite some time to decide, sorry) you will be 'handed over' to one of our in-house design engineers who will, I have noticed on several occasions, bend over backwards to turn your humble idea into a full-blown DIY project in Elektor style, possibly with a PCB and software to download. We are currently the only English-language electronics magazine in the world with a fully equipped in-house design lab and 30 years consistency in PCB design. I guess that's the reason why readers ask if they may contribute to Elektor Electronics in the first place: with the exception of Readers Circuits (which are clearly identified as such by a footer text) our articles contain circuit diagrams and PCB designs with uniform characteristics often described as 'Elektor style'. Our design engineers will happily turn an idea on the back of an envelope into an Elektor PCB and the editorial team is ready to correct, expand, restructure and generally improve your write-up to produce an article with impact and appeal to tens of thousands of readers. The only proviso is that your idea is original and not overly specialised as that limits the number of readers who will be interested. A prototype plus a mention of what you actually do with your design will considerably help your case. Over to you!

Jan Buiting
Editor

14 BIOMETRICAL IMAGING

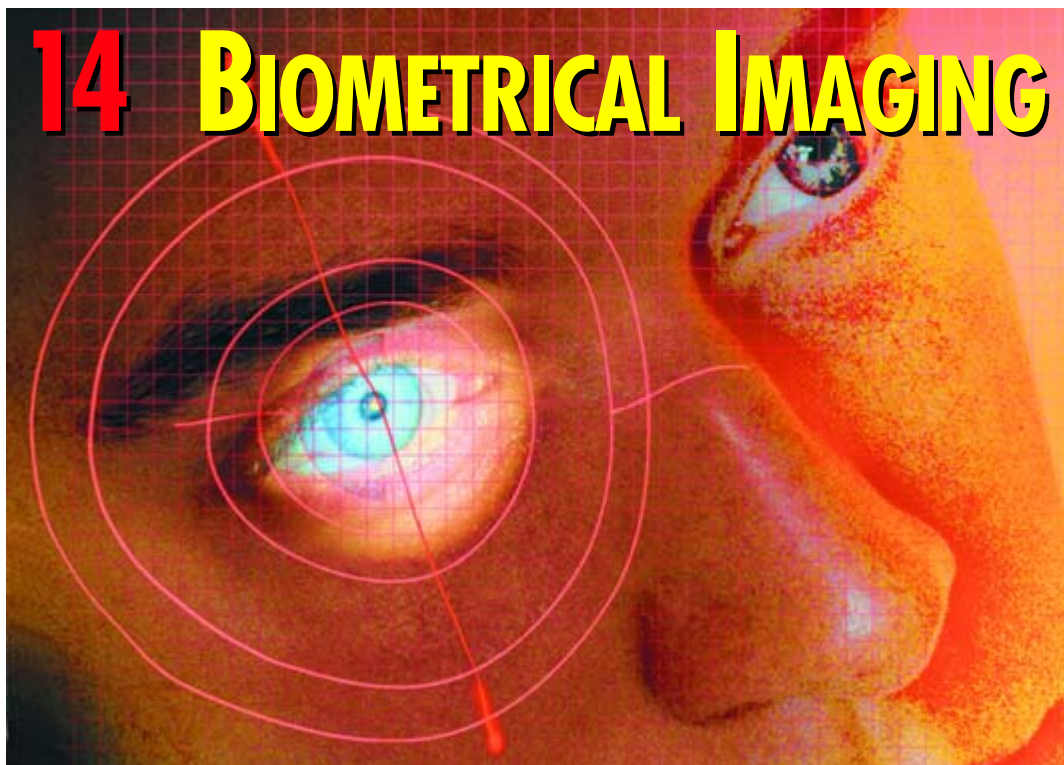

Biometry is likely to be used in the near future for passports and many other applications related to security and identification. However, the performance of biometry for many applications is not yet good enough and a lot of research is required to obtain the necessary improvements. In this article we provide some insight into the technology used and we not only discuss how and why biometry works but also why the systems sometimes fail.

20 Fingerprint as Password

Passwords have not shown themselves to be a foolproof form of identification, and the trend is now towards biometric methods, including fingerprints, becoming more widely used. We look at how fingerprint sensors work and at the advantages and disadvantages of the various techniques.



32 Colossus Jr.



There is another use for cryptography, which has more to do with keeping things in the open. This other use, which rightly belongs in this issue on All Things Security, is data authentication: techniques for verifying that data has not been tampered with.

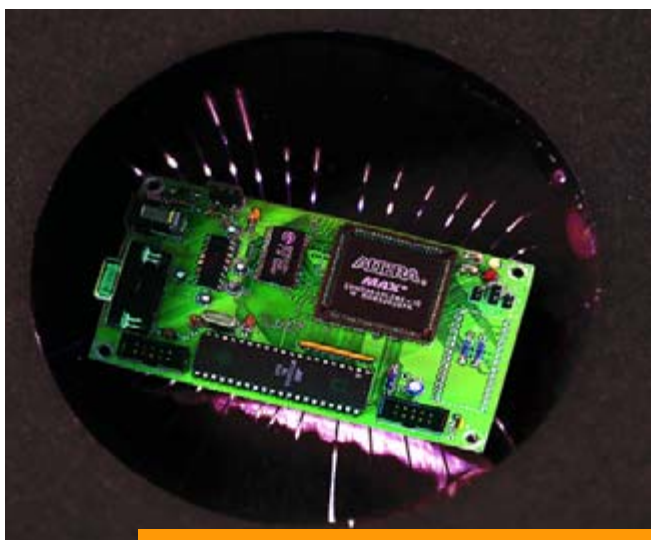

38 27C512 Emulator

In this article, we work through the entire design process for a CPLD project from start to finish using a practical example. The result is a handy 27C512 EPROM emulator that is useful for debugging microcontroller systems.

know-how

- 14** Biometrical Imaging
- 20** Fingerprint as Password
- 58** WiMAX Primer

hands-on

- 32** Colossus Jr.
- 38** 27C512 Emulator
- 54** Remote Control Operator
- 68** Mini Project: Flash Lock for PCs
- 72** Labtalk: the noiseless PC
- 74** Design Tips
 - Cascode stage
 - Pot as interrupt generator

technology

- 28** Fingerprint Sensors
- 48** Delphi for Electronic Engineers (8)
- 64** TIRIS RFID Reader

info & market

- 6** Colophon
- 8** Mailbox
- 9** Corrections & Updates
- 10** News & New Products
- 82** Elektor SHOP
- 84** Sneak Preview

infotainment

- 77** Retronics:
 - Elektor Time Standard (1988)
- 78** Quizz'away (13)

Design and Run a Digital Filter in SECONDS!

Signal Wizard 2: Easy-Use Real-Time Digital Filter and Analyser

Signal Wizard 2 is a unique real-time audio-bandwidth digital filter with infinitely adjustable characteristics – available at the click of a button. It uses a DSP unit that runs the filter and a Windows interface for designing and downloading almost any kind of filter. You don't need to know about maths, DSP or filter design – all you need to know is what filter you want. Signal Wizard designs finite impulse response (FIR), infinite impulse response (IIR) and adaptive filters in seconds. You can even import your own impulse or frequency responses. After you've designed the filter, click a button to download and run. Simple! Its flash memory means it can run filters from start-up, without the need for a PC.

Key Features:

- Runs under Windows 98 and XP.
- FIR: Multiple pass, stop or arbitrary, Butterworth, Chebyshev, analogue networks.
- Linear or arbitrary phase; response import mode.
- Rectangular, Bartlett, Hamming, Hanning, Blackman and Kaiser windows.
- Inverse or flipped filters.
- IIR: Butterworth, Chebyshev and arbitrary.
- Adaptive filter for noise cancellation.
- Independent dual channel operation with 24-bit resolution.
- Real-time dual channel scope and spectrum analyzer with data capture.
- Mixing, inversion and delays from 21 microseconds to 1.8 seconds.
- Real-time gain and sample rate control.
- Up to 8 filters in flash, two selectable, one per channel.
- Stand alone operation.
- Twelve sample rates from 48 kHz down to 4 kHz.
- Versatile plot and export of impulse and frequency responses.
- Off-line filter option for wave files.
- Includes board, CD, power supply and all cables.
- Serial interface operating at 115.2 kilo baud (auto-selected).

US \$399
(UK £230)

For more information
Email: info@saelig.com

Full details and ordering information at: www.saelig.com/Suppliers/ezfir/signalwizard2.htm

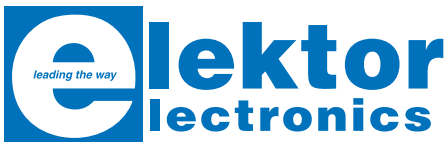

Volume 31, Number 347, October 2005

ISSN 0268/4519

Elektor Electronics aims at inspiring people to master electronics at any personal level by presenting construction projects and spotting developments in electronics and information technology.

Publishers: Elektor Electronics (Publishing), P.O. Box 190, Tunbridge Wells TN9 7WY, England. Tel.: (+44) (0)1580 200657, fax: (+44) (0)1580 200616. www.elektor-electronics.co.uk.

The magazine is available from newsagents, bookshops and electronics retail outlets, or on subscription. *Elektor Electronics* is published 11 times a year with a double issue for July & August.

Under the name *Elektor* and *Elektuur*, the magazine is also published in French, German and Dutch. Together with franchised editions the magazine is on circulation in more than 50 countries.

International Editor: Mat Heffels (m.heffels@segment.nl)

Editor: Jan Buiting (editor@elektor-electronics.co.uk)

International editorial staff: Harry Baggen, Thijs Beckers, Ernst Krempelsauer, Jens Nickel, Guy Raedersdorf.

Design staff: David Daamen (head of design), Ton Giesberts, Paul Goossens, Luc Lemmens, Karel Walraven

Editorial secretariat: Hedwig Hennekens (secretariaat@segment.nl)

Graphic design / DTP: Ton Gulikers, Giel Dols

Managing Director / Publisher: Paul Snakkers

Marketing: Margriet Debeij (m.debeij@segment.nl)

Subscriptions: Worldwide Subscription Service Ltd., Unit 4, Gibbs Reed Farm, Pashley Road, Ticehurst TN5 7HE, England. Telephone: (+44) (0)1580 200657, Fax: (+44) (0)1580 200616. Email: admin@worldwidesubscriptions.com. Rates and terms are given on the Subscription Order Form

Head Office: Segment b.v. P.O. Box 75 NL-6190-AB Beek The Netherlands. Telephone: (+31) 46 4389444, Fax: (+31) 46 4370161

Distribution: Seymour, 86 Newman Street, London W1P 3LD, England

UK Advertising: Huson International Media, Cambridge House, Gogmore Lane, Chertsey, Surrey KT16 9AP, England. Telephone: +44 (0)1932 564999, Fax: +44 (0)1932 564998. Email: relgar@husonmedia.com. Internet: www.husonmedia.com. Advertising rates and terms available on request.

International Advertising: Klaas Caldenhoven, address as Head Office. Email: advertenties@elektuur.nl. Advertising rates and terms available on request.

Copyright Notice

The circuits described in this magazine are for domestic use only. All drawings, photographs, printed circuit board layouts, programmed integrated circuits, disks, CD-ROMs, software carriers and article texts published in our books and magazines (other than third-party advertisements) are copyright Segment. b.v. and may not be reproduced or transmitted in any form or by any means, including photocopying, scanning or recording, in whole or in part without prior written permission from the Publishers. Such written permission must also be obtained before any part of this publication is stored in a retrieval system of any nature. Patent protection may exist in respect of circuits, devices, components etc. described in this magazine. The Publisher does not accept responsibility for failing to identify such patent(s) or other protection. The submission of designs or articles implies permission to the Publishers to alter the text and design, and to use the contents in other Segment publications and activities. The Publishers cannot guarantee to return any material submitted to them.

Disclaimer

Prices and descriptions of publication-related items subject to change. Errors and omissions excluded.

© Segment b.v. 2005

Printed in the Netherlands

featured products



NETCOM-813
8 Port RS232/RS422/RS485 model
£350

NETCOM Ethernet- Serial Servers

NetCom are industrial strength, network based serial device servers for connecting RS232, RS422 and RS485 serial devices directly to a 10/100Mbps Ethernet network running TCP/IP. NetCom can control 1 or more serial devices located virtually anywhere (via Ethernet or Internet). NetCom can be configured over Driver Panels, WEB Browser, Serial Port, Telnet or SNMP and serves as a transparent serial channel without platform and distance limitation. Housed in a sturdy metal enclosure including DIN rail mount, one to eight port models are available. 19in rack-mount versions with internal switch mode PSU can also be supplied.

priced from £85 (NetCom 111)



DS1M12 Oscilloscope / Datalogger
2 1MS/s Input Channels + waveform generator output
£125

USB Instruments - PC Oscilloscopes & Logic Analyzers

Our range of PC Instruments may be budget priced but have a wealth of features normally only found in more expensive instrumentation. Our DS1M12 and PS40M10 oscilloscopes have sophisticated digital triggering including delayed timebase and come with our EasyScope oscilloscope / spectrum analyzer / voltage and frequency display application software and our EasyLogger data logging software. We also provide Windows DLLs and code examples for 3rd party software interfacing to our scopes. Our ANT8 and ANT16 Logic Analyzers feature 8/16 capture channels of data at a blazing 500MS/S sample rate in a compact enclosure.

priced from £125 (DS1M12 & ANT8)



USB-16COM-RM
16 Port USB Serial Server Rack Mount with Internal PSU
£265

1 to 16 port USB to Serial Adapters

With over 16 different models available, we probably stock the widest range of USB Serial Adapters available anywhere. We offer converter cables, multi-port enclosure style models in metal and plastic, also rack mount units such as the USB-16COM-RM opposite. Serial interfaces supported include RS232, RS422 and RS485. We also supply opto-isolated RS422 and RS485 versions for reliable long distance communications. All our USB Serial products are based on the premium chipsets and drivers from UK company FTDI for superior compatibility, performance and technical support across Windows, MAC-OS and Linux platforms.

priced from £20 (US232B/LC laptop Companion)



PCI-800L
8 Port PCI RS232 Serial card
£150 (including cables)

PCI Serial Cards

Discover our great value for money range of multi-port PCI serial cards. Supporting from two to eight ports, the range includes RS232, RS422, RS485 and opto-isolated versions. Our 4 port and 8 port models can connect through external cables or the innovative wall mounting COMBOX.

EasySync Ltd

373 Scotland Street, Glasgow G5 8QB, United Kingdom
Tel : 0141 418 0181 / Fax : 0141 418 0110

Web : <http://www.easysync.co.uk>
E-Mail : sales@easysync.co.uk

* Prices shown exclude PP and VAT where applicable

GPS Receiver on USB



Dear Jan — I have to admit I became quite excited at the prospect of building my own GPS receiver for a reasonable cost (complete kit available) (June 2005, Ed.). I have wanted to experiment with GPS aided navigation for a while now. So this project was very appealing to me. Before purchasing the kit though, I started looking at Route Planning Software with GPS support, such as those suggested in the article. Oh dear, what a disappointment I was faced with... I looked on the amazon.co.uk website for what was currently available, particularly the two programs mentioned in the article, namely MS AutoRoute 2005 & Route 66.

To my dismay, both these programs were reviewed by purchasers and were given extremely low scores. There were complaints concerning the maps not being up to date, roads missing entirely, and most of Ireland not existing! Europe coverage was said to be worse than previous versions, and some comments about the earlier editions being marginally better, such as new roads that have been in service for around 3 years not included in the latest versions, nor the M6 toll road which is also missing as well as changed road layouts that have been in force since the earlier issues. Some of this software is priced at up to £50 – a lot to pay to be disillusioned.

All of this has really messed up my enthusiasm now. A potentially good and useful Elektor project being let down by possibly poor commercial software. I would hope that no one else falls into the same trap and builds a project that has a poor support.

I would be interested in any comments from the authors of the article as to their opinions of these reviews, and suggestions of any alternate software with up to date UK & Europe coverage and updates / plug-ins for other countries.

Patrick Redway (UK)

Many thanks for your useful comments. I have copied this email to the project designer, Mr. Paul Goossens.

Your claim that our project is 'supported' by commercial software (of whatever quality according to reviews) is, of course, doubtful as we only published hardware that's open for connection to software from third parties we are not commercially linked to, and over which we have absolutely no control.

The USB GPS kit and the associated article in the June 2005 issue have met with wide acclaim from an impressive number of readers. None the less, let's hope the quality of the software packages you mention does improve, or that there are simply better products available. Possibly the alleged poor support of MS Autoroute and Route 66 only applies to UK and Eire maps, we are not aware of similar problems for the countries we did our testing in (Holland and Germany). Other readers may have recommendations for alternative software?

Elektor software on 45 rpm vinyl records

In response to my call for 45 rpm vinyl records originally supplied through our Readers Services as part of the former Elektor Software Service (ESS) (see *Retronics*, April 2005), Rolf Meier of Freiamt, Germany, responded not only by informing us that he has mint copies of all ESS discs including sleeves, but also by emailing a scanned image of ESS record # 005, once a hit, now a Golden Oldie!

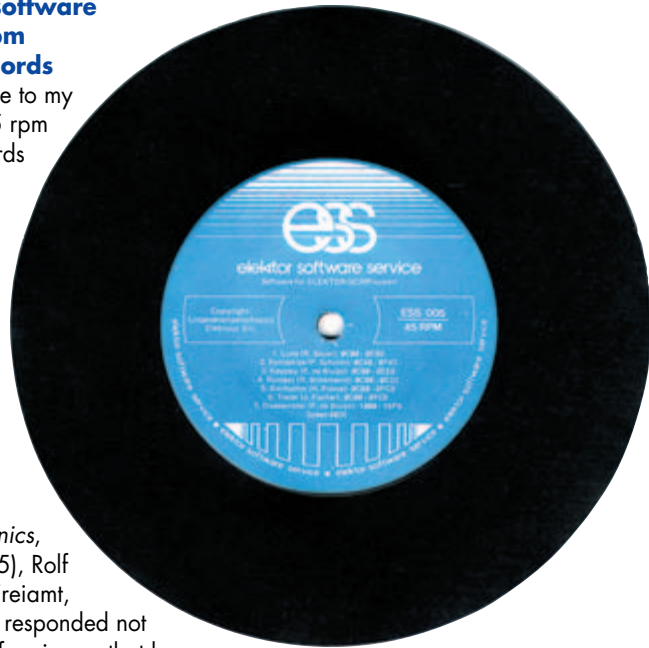

Successfully tested

- Mini Cooper S 2002 (ISO-9141)
- Opel Corsa 2003 CDTI (KWP2000)
- Citroen c3 1.4i 2004 (KWP2000)
- Citroen Berlingo 1.9d 2003 (KWP2000)
- Toyota Prius
- VW Golf TDI 130hp 2002 (ISO-9141-2)
- Renault Scenic 2001
- VW Touran 2005 (KWP2000)
- Mercedes A160 2004
- Volvo V70 D5 2003 (ISO-9141)
- Peugeot Expert HDI 2001 (KWP2000)
- VW Passat TDI 1994 (ISO-9141-2-ish)
- VW Passat 2.0 petrol 2001
- VW Golf 1.9 TDI 2000
- Land Rover Discovery 2004 diesel (CAN)
- Toyota Camry CE Canadian 1997
- Toyota Corolla 1.4 2005
- VW Passat Diesel 2005
- Suzuki Grand Vitara Diesel 2001 (KWP2000 slow init)
- Volvo 850 Petrol 1996

OBD-2 Analyser success story

From correspondence with individual readers and input to our international website forums we have been able to extract a list of car makes and types Elektor readers have used the OBD-2 Analyser with (status: mid-July 2005). Please use the *Elektor OBD-2 Analyser* topic in our online Forum to contribute to the list, exchange ideas and help other readers.



Corrections & Updates

Programmer for DCC Model Railway Control

May 2005, p. 46, 040422-1

The article states that the microprocessor fuse bits have to be set to the defaults of the Pony programmer software. Because the Pony defaults are different from the microprocessor's factory defaults, they are repeated here: none of the 16 bits must be programmed (they must be left at '1'), except SPIEN. SPIEN (serial program enable) should be left at the factory default, i.e., programmed ('0'). The factory defaults will cause the chip to operate at the 1-MHz internal oscillator instead of the 8-MHz external quartz clock. You can easily verify that the chip is running on the external quartz clock. Connect a DVM in DC voltmeter mode to pin 19 of the processor. The level measured should be between 0.5 V and 1.5 V. If not, ICs supplied through our Readers Services (item code 040422-41) should be returned to our software service department for free reprogramming.

Code Lock with one Button

July/August 2005,

p. 90, 040481-1

The circuit diagram should be modified to show a common-cathode (CC) display in position LD1. A suggested type is the LITE-ON LSHD-5503. Supply decoupling capacitor C1 is not shown on the component overlay and may be fitted at the underside of the board.



OBD-2 Analyser

July/August 2005,

p. 18, 050092-1

In certain cases the reset pulse

is too short, causing the red LED to light only and the green and yellow LED to remain off all the time. Contrary to what is mentioned in the article text, it is better to fit IC7 and C7. A solder spot is available for the negative terminal of the electrolytic capacitor, while the positive terminal is connected to the centre pin of IC7.

Precision Barometer/Altimeter

September 2005,

p. 54, 040313-1

Due to a change in the control software, a few small modifications are required on PCB no. 040313-1. PCBs already supplied through Readers Services, or made at home using the artwork originally supplied, may be modified as detailed below.

The two PCB tracks leading to pin 1 (MCLR) of IC2 are cut as close as possible to the IC pin and then connected to each

another only, using a small piece of wire. The track between pin 4 (RA2) of IC2 and junction R7/S1 is cut in the vicinity of pin 4. Next, the interrupted track coming from R7/S1 is connected to pin 1 of IC2.

Noise Suppression for R/C Receivers

July/August 2005,

p. 104, 054018-1

In the circuit diagram and on the PCB, pins 1 and 2 of connectors K9 through K16 have been transposed. The PCB may be modified to prevent reworking (ready-made) servo cables.

On the PCB, swap connections 1 and 4 of inductor L9. Disconnect the tracks to both pins, then solder a piece of light-duty wire between pin 1 of the inductor and pin 1 of K17. Next, solder a second piece of wire between inductor pin 4 and pin 2 of K17.

Toyota Yaris Verso petrol 2002
Peugeot 206 petrol 2002 (KWP2000 fast init)
Toyota Corolla CE 2004 (North American)
Toyota Camry CE 1997 (North American)
Mazda Protege 2000 (North American)

No success (yet) / undetermined

Ford Scorpio 2.3 1997
Ford Scorpio 2.3 1997 (ECU: EEC-V)
Toyota Landcruiser 2004
Audi A8 Quattro 2.8 1997.
Citroen Xsara coupe 1.8i 16V VTS 1999
Peugeot 307SW diesel 2003.
Landrover Defender 110 DCPU
Volvo V70 -05 and -03
Nissan Sentra GE 1.8 2001 USA

Summer Circuits 2005 edition is a download

Dear Jan — a quick note to say thank you for making the complete July/August 2005 issue available online. I hope it was

successful enough to make it a permanent option.

Terry Mowles (UK)

Thanks for the feedback, Terry (and others who have responded through the Contact Form on our website). The experiment was successful enough to convince our Publisher to put the September 2005 issue online, too, this time at about 15% less than the UK cover price!

I believe we are now well on our way towards the online subscription to your favourite magazine.

A bare bones PC

Dear Editor — recently I stripped my old Pentium system from everything useful like memory cards and storage media. In exchange for a few pounds I got my hands on a second-hand ATX case with mainboard and a Pentium-2

processor. I filled this case with the useful bits from my ancient PC. A fine 17-inch CRT monitor was picked up at a carboot sale for 20 pounds.

I would like to suggest this method to other readers. Many of the latest PCs are overdimensioned in respect of speed and storage capacity. If you are happy with just Internet access, e-mail, playing the odd music CD, word processing, a bit of spreadsheets and so on, a P2 at 266 MHz and a 5-10 GB hard disk is wholly adequate.

Gert Baars (Netherlands)

I agree Gert, my own hobby PC at home is also a 300-ish MHz P2 with a 17-inch CRT. Still running Windows 98SE this relic gives me great satisfaction and no worries of blowing up expensive bits or messing with the family's programs and email. These are safe, I hope, on a 3-GHz multimedia PC installed in the living room and linked to a wireless

network.

Other readers having ideas on recycling old PCs and an article or two about the subject are invited to respond!

MailBox Terms

- Publication of reader's correspondence is at the discretion of the Editor.
- Viewpoints expressed by correspondents are not necessarily those of the Editor or Publisher.
 - Correspondence may be translated or edited for length, clarity and style.
- When replying to Mailbox correspondence, please quote Issue number.
- Please send your MailBox correspondence to:

editor@elektor-electronics.co.uk or
Elektor Electronics, The Editor, P.O.
Box 190,
Tunbridge Wells TN5 7WY, England.

Humidiprobe® temperature and humidity data logger

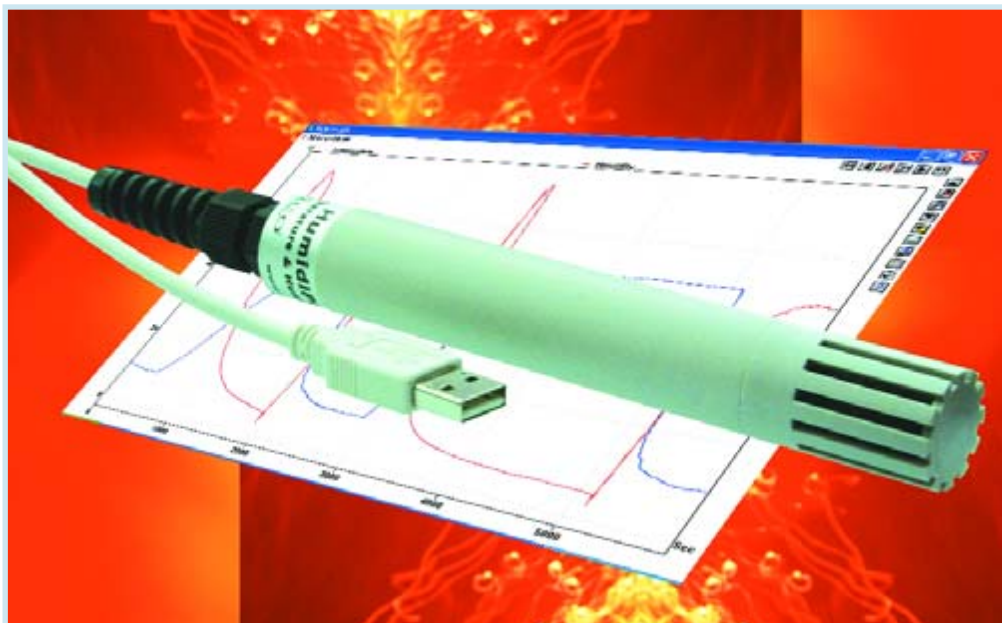

Pico Technology has announced the immediate availability of the HumidiProbe, a combined environmental probe, analogue-to-digital converter and data logger in a slim, lightweight case. HumidiProbe simply plugs in to the USB port to give instant, highly accurate measurements of

temperature and humidity. Up to 4 HumidiProbes can be connected to one PC, allowing you to accurately monitor the temperature and humidity in multiple locations at once.

HumidiProbe can measure temperatures over the range 0°C to +70°C with an accuracy of

±0.5°C, a resolution of 0.01°C and a response time of 5 to 30 seconds. It measures relative humidity over the range 0% to 100% with an accuracy of ±2%, a resolution of 0.03% and a response time of 4 seconds. The conversion time for both sensors is 2 seconds. HumidiProbe is com-

patible with all USB 1.1 and USB 2.0 ports, making port selection and configuration automatic and reliable. There is no need for batteries or a separate power supply, as the probe takes its power from the USB port.

HumidiProbe is supplied with the easy-to-use PicoLog® software, which is a powerful and flexible program used to collect, display and analyse data. Measurements can be viewed in graph, spreadsheet and text formats, saved to a file or replayed for off-line analysis. In addition, software alarms can be configured to give a warning when either temperature or humidity measurements go out of a specified range. Free updates to the software are available on the company's website.

HumidiProbe is available immediately direct from Pico Technology or one of its authorised distributors at a cost of £149 + VAT. Further information can be obtained from the Pico Technology website at www.picotech.com or by calling +44 (0) 1480 396 395.

(057146-1)

40A out synchronous buck converter

International Rectifier recently introduced the iPOWIR™ iP2003A, a fully-optimized power "building block" solution for high current, multiphase synchronous buck converters with a 3V to 13.2 V input voltage range. The new building block is designed specifically for low voltage power rails in servers, desktops and data communication systems.

As part of the iPOWIR family, the iP2003A integrates silicon and passive components into a single, compact land grid array (LGA) package. The integrated silicon includes a synchronous gate driver, high side and low side power MOSFETs, and a synchronous Schottky rectifier for reduced deadtime losses. The device is capable of 1 MHz operation with an output current rating of 40 A continuous with no derating up to a 100°C case

temperature.

Together with a standard multiphase PWM controller, a four phase converter using four iP2003A devices can deliver 160 A output current with a 55% board space savings compared to an equivalent solution using thermally-enhanced SO-8 power MOSFETs.

In addition, since the iP2003A integrates the critical power and passive components required for each phase of the converter, design complexity and layout time are greatly reduced versus a standard discrete solution. An external PWM controller, input plus output capacitors, and output inductors are the only additional components required to realize a complete solution.

The iP2003A uses a patent-pending package technology which enables dual-sided cooling capability via very low junc-



tion-to-case and junction-to-PCB thermal resistance for maximum current handling.

International Rectifier,
www.irf.com,
Tel. (+44) (0)20 8645 8003

(057146-2)

Maplin's 2005/2006 catalogue

One of the UK's leading retailers and distributors of components, accessories and equipment, Maplin Electronics Ltd is now mailing copies of their brand new 2005/06 catalogue.

The famous Maplin catalogue is hot of the press with over 18,000 new lines including, audio, video, electronic, computer products, components and accessories. It's designed to provide you with a clear guide to Maplin's massive and ever-growing range of specialist electronic products and contains a wealth of information allowing you to make informed purchases.

Priced at just £3.99 this industry bible for electronics is jam packed full of the very latest affordable innovative electronic products with great new features including a brand new 'Free to Air Satellite' category, which includes DVB and all

associated accessories, our broadened GPS range with the new lower cost TOM TOM GO, Garmin Quest and the StreetPilot 320 and a number of new products for voice communication over the Internet.

You can save even more money with over £200 worth of special offer vouchers and discounts inside – to order your complete catalogue for electronics call the Maplin order hotline now for quick and efficient service and get yours delivered to your door on 0870 429 6000 – UK Product Code CA27, Ireland Product Code CI27 – No delivery charge included With such a depth of product range make Maplin your first stop for any electronics and technology! Maplin Electronics has a network of over 100 branches across the UK and Ireland.

www.maplin.co.uk

(057146-8)

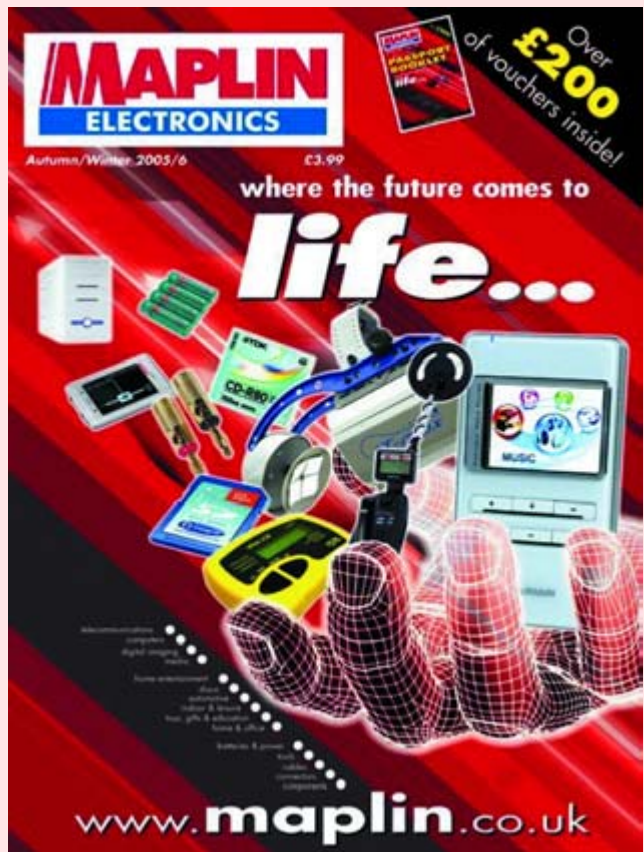

Turn your PDA into a measurement device

Engineers and scientists can now turn standard PDAs into customised, portable measurement tools with the new National Instruments CompactFlash data acquisition (DAQ) device. The NI CF-6004 device – which is slightly larger than a standard passport photo – plugs into any PDA with a CompactFlash slot to create a handheld instrument with the processing and wireless communication capabilities of the latest PDA devices.

The NI CF-6004 is a 14-bit multifunction data acquisition device that plugs directly into a PDA CompactFlash slot to provide up to 200 kS/s single-channel sampling on four analogue input channels in a handheld form factor. It also offers four lines of digital I/O for controlling and measuring LVTTTL or LVCMOS signals. Engineers can use the NI LabVIEW graphical programming environment for Pocket PC to acquire, analyse and view the data on their PDAs. The flexibility and mobility of the NI CF-6004 make it ideal

for applications such as wearable computing, field monitoring and field diagnostics, as well as in laboratory and educational settings. Compared to buying several traditional, handheld instruments, engineers can save valuable space by using a single PDA with LabVIEW and the NI CF-6004 DAQ device.

Because engineers can define their own unique instruments in LabVIEW and then easily deploy them to their handheld devices, they can also change and redeploy these applications to repurpose their PDAs for new measurements.

In addition, because PDAs are typically less expensive than laptops, PDA-based data acquisition is a cost-effective option for handheld, portable instruments.

National Instruments UK & Ireland,
www.ni.com/uk,
Tel. (+44) (0)1635 523545.

(057146-6)



60V microelectronic relay

International Rectifier recently introduced the PVG612A series of microelectronic relays (MER) that have as much as 40% more current handling capability and up to 50% better on-resistance than similar competing devices. Packaged in a six-pin DIP, the PVG612A is used in a vast variety of switching applications, including programmable logic controllers, audio equipment, computers and peripherals, power supplies, load distribution to displays, indicators and industrial automation. The PVG612A is a single-pole, normally open solid-state relay. It utilizes an integrated circuit photo-

voltic generator and IR HEXFET® power MOSFET transistors as the output switch. The switch is controlled by radiation from a light-emitting diode that is optically isolated from the generator. The PVG612A is rated at 60V, with 3 A AC or 6 A DC maximum load current, and features an input drive of 5 mA, making the new PVG612A fully TTL compatible. The device is offered in through-hole, surface mount and tape and reel package options. Further information from IRF's European Regional Centre, tel. (+44) 20 8645 8003, or www.irfcom.

(057131-5)



Ultra-compact transducer for very high AC & DC currents

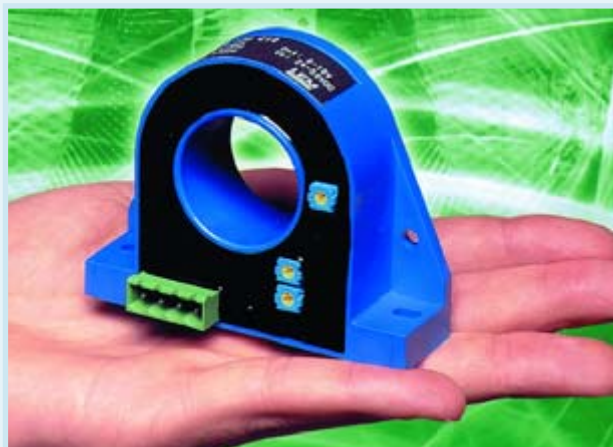

LEM has introduced a family of current transducers that combines Hall-effect technology and a signal conditioner in a compact case to offer dramatic savings in size (up to 75% compared to other current transducers) for measuring nominal currents up to 1000 A true RMS. These new transducers measure only 90 x 70 x 34 mm.

The DHR series has been designed to measure DC signals as well as distorted current waveforms such as variable frequency drive (VFD) outputs. Additional features include the choice of primary current measuring ranges from 100 A to 1000 A, choice of output options (4-20 mA, 0-5 V or 0-10 V), a wide power supply

range (24 to 50 VDC) and a large sensing aperture (32 mm) for non-contact measurement. The new transducers provide an absolute accuracy of better than 1 percent of the nominal current over a broad range of inputs. This, coupled with a wide bandwidth from DC to 6 kHz, an operating range of -40 to +70°C and a true RMS computation for non-linear loads or 'noisy' environments, makes them an excellent choice for industrial system designers, system integrators and automation distributors looking for accurate and cost-effective AC or DC current transducers.

LEM UK Ltd, www.lem.com, Tel: (+44) (0)1695 720777.

(057146-5)

Low-cost PIC development programmer and starter kit

Microchip has announced the PICkit™ 2 Starter Kit, which enables engineers, students and anyone with an interest, to easily begin development and experimentation with PIC microcontrollers. The PICkit 2 follows the very successful PICkit 1 offering improved ease of use, faster programming and greater flexibility. The PICkit 2 Starter Kit connects to any personal computer via full-speed USB 2.0, which allows firmware upgradeability, and requires no additional power supply for the programmer or target application board. The PICkit 2 comes with a set of easy-to-

understand tutorials that allow users to learn at their own pace. In addition, the PICkit 2 can eas-

ily plug into development boards via In Circuit Serial Programming™ (ICSP™) technology.

The PICkit 2 Microcontroller Programmer (PG164120) is expected to be available in August for \$34.99 USD, and comes with a USB cable. The PICkit 2 Starter Kit (DV164120) is also planned for August for \$49.99 USD, and includes the programmer, USB cable, CDs and an 8/14/20-pin evaluation board. Initially, the programmer supports 33 different low pin count, Flash PIC microcontrollers. For additional information visit the Microchip Web site at www.microchip.com/tools or call European Headquarters on (+44) (0)118 921 5869



(057146-3)



New B² Spice V5 Our hottest Spice ever

New B² Spice Version 5 has all the power and functions you expect from a professional Spice package, but without the high cost:

- Real design flexibility with over 30,000 models, unlimited circuit size and a huge range of new virtual instruments
- New Circuit Wizard saves time by auto-generating many designs for you
- Sweep all parameters for any component and simulation type with the powerful new Scenario Editor
- Live Circuit feature allows values to be adjusted while simulations are running, displaying the results in real time

Professional standard Spice simulation for just £229 + VAT. Plus educational and multi-user licence discounts available and **FREE** comprehensive telephone technical support. **Try the full version completely free for 30 days.**

www.spice-software.com
Tel: 01603 872331

Research House, Norwich Road, Eastgate
Norwich. NR10 4HA. Fax: 01603 879010
Email info@looking.co.uk



Biometrical Imaging

The thin line
between science
and electronics

Dr. ir. Asker M. Bazen
University of Twente, The Netherlands

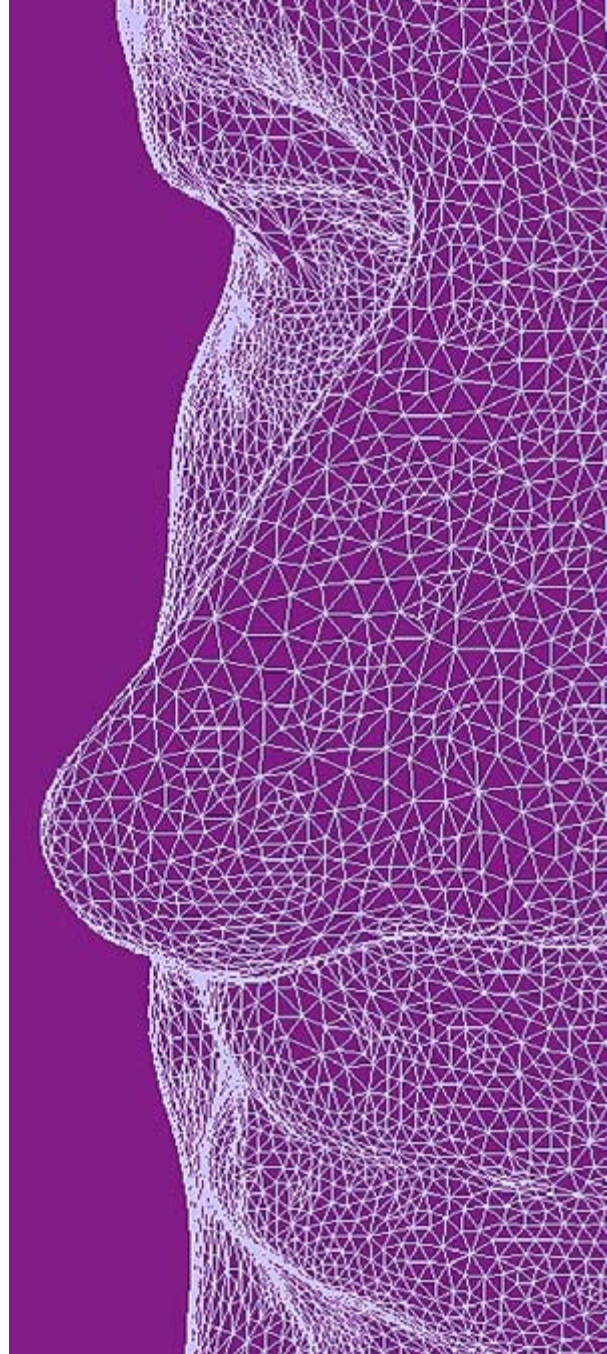

Biometry or biometrics is currently in the limelight, largely because this technology is likely to be used in the near future for passports and many other applications related to security and identification. However, biometry has not reached the end of development yet. The performance for many applications is not yet good enough and a lot of research is required to obtain the necessary improvements. In this article we provide some insight into the technology used and we not only discuss how and why biometry works but also why the systems sometimes fail.

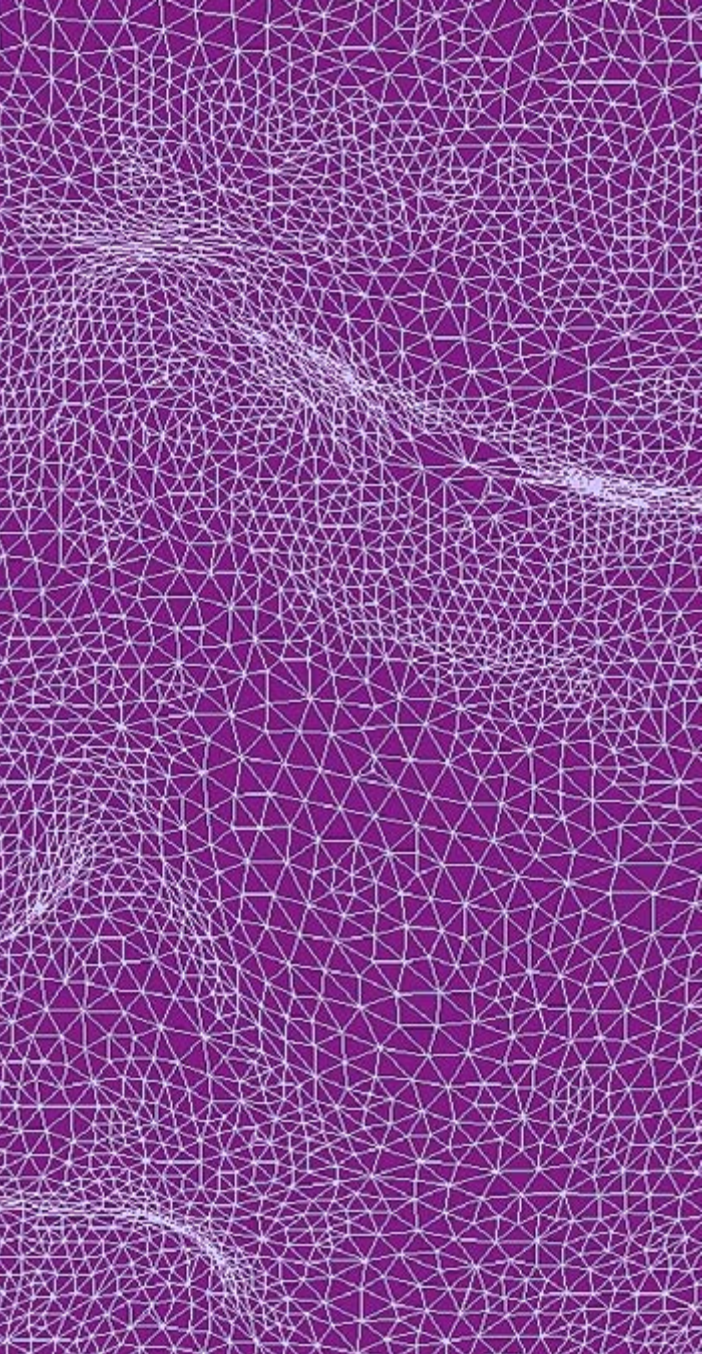

larities. For example, on two different photographs of someone's face the angle of illumination or the facial expression can be different. On the other hand, photographs of brothers or sisters can be very similar. In order to recognise a person despite these differences and similarities between measurements, the biometric system needs a clever method to determine if there is sufficient correspondence between two measurements. This is done by using the characteristic features of a measurement, the so-called feature vectors. The big challenge when developing the algorithms for biometric recognition is finding suitable feature vectors, which represent just those characteristics that give the greatest difference.

Face recognition

An attractive method of identifying people is face recognition. In principle this could even take place transparently, that is, without explicit cooperation of the individual to be recognised. In practice this technique has not yet advanced to the point that this works reliably. The big problem for face recognition is the large variation between different pictures of the same face.

There are two types of variations. Intrinsic variations are caused by actual changes in the face, such as facial expression, hairstyle, beard, etc. Extrinsic variations are caused by, or during, the recording process: variations in illumination, pose, resolution, partial obscuration, etc. The photographs in **Figure 1** are good examples of these.

Depending on the context, ageing can also play a role. If a system is used frequently, the stored data can easily be amended to account for the differences caused by ageing. But when used in a biometric passport that should last at least five years, the false rejection rate (FRR), that is, the percentage of wrongful rejections can increase to more than 50%. You can read more about FRR and other statistical biometric measurements in the **inset**.

Different pictures of the same face can be very different but also be very similar. The most obvious example is identical twins (whose fingerprints are, by the way, always different). But also other members of the family or even totally unrelated people can be strikingly similar. An example of this is **Figure 2**. The question here is: are these three different ladies, three different photos of the same lady or some other combination. The solution appears at the end of this article.

Features

There are two types of features or characteristics that can be used for face recognition. The first type makes direct use of the grey-scale values (texture) of the image, refer to the top row of images in **Figure 3**. Here a matching score is determined by using a type of weighted sum of the difference of grey-scale values between different pictures. The second feature type is based on geometry (shape) of the face, which makes use of standard facial features such as eyes, nose and mouth (bottom row in **Figure 3**). The first step is searching for the characteristics in the image. From this a graph is constructed, which is then compared to the reference data. For better recognition it is possible to combine both these methods in one algorithm. A new development in face recognition is the

Biometry or biometrics is the automatic recognition of people based on measured body characteristics or behaviour. The most familiar examples of biometry are fingerprint recognition, face recognition and iris scans. Furthermore, hand geometry, speech recognition, writing and signature recognition and gait (the characteristic way of walking) are examples of other methods that are used and being researched. A different, and relatively new form, of biometry, is recognition of handprints. Experiments are currently being carried out using this technique in prototype pistols, in order to secure them against unauthorised use, without hampering the shooter. A pistol into which you have to enter a code is not all that useful in an emergency.

Face recognition and finger print recognition are perhaps the best well-known methods of biometry. However, that does not necessarily mean that they are the simplest methods. With these forms of biometry as well, there are two annoyingly recurring problems. When two biometric measurements are made on a person, the results will never be exactly the same. At the same time, biometric measurements from different people can have strong simi-



Figure 1.
Variations in a face:
expression, lighting
and pose.

use of 3-dimensional scans. An advantage of 3D face recognition is that it is less sensitive to illumination and pose, but research on how 3D scans can be optimally used for recognition has only just started. Because face recognition at this stage is not sufficiently robust for large-scale application, the only viable application is low-security access control with small groups of users.

Fingerprints

These days, fingerprints are usually recorded digitally. This is typically done by making an optical or capacitive measurement of the surface of the fingertip. This generally leads to an 8-bit grey-scale image of about 500 by 500 pixels. The tip of the finger has so-called ridges and valleys. In a fingerprint these are visible as parallel running curved black and white line structures. A global description of the shape of the print is given by the orientation field: the direction of the lines in every part of the print. There are a few major classes, which are called the Henry classification. **Figure 4** shows three of these basic forms. Within each class there are several possible variations.

The second level of detail is provided by the minutiae. These are the division and endpoints of the lines that describe the local details of the fingerprint. Minutiae are the characteristics that are used most often for automatic fingerprint recognition. In addition, some systems also use the original grey-scale image, which contains the greatest amount of detail. The orientation field and the minutiae are visible in **Figure 5**.

Just as with other methods of biometry, the biggest problem with fingerprint recognition is that two prints of the same finger are never exactly the same. One of the causes is image quality. There can be dirt and (temporary) scratches on the finger, there is measurement noise in the sensor, and the weather can cause poor prints. In addition, some people have poor fingerprints in any case, for example because of wear, or caused by (genetically) shallow crevices. In such cases it is even for an expert almost impossible to indicate where the lines exactly go. In an automated system this leads to false, missed or displaced minutiae. A second cause is that the finger is positioned ever so slightly different each time it



Figure 2.
Similar faces:
three different ladies or
three the same?

(Mis)match!

The process of biometric recognition is described in the block diagram of **Figure A**. Here the characteristics of a person (features) are compared with characteristics stored earlier. This comparison results in a matching score. A threshold determines whether a score is high enough to determine a person 'recognised'. However clever the 'feature extraction' is, there will always be situations where two feature vectors of the same person are sufficiently different to result in a low matching score.

Also, two measurements from different people can be very similar, which results in a high matching score. This means the matching scores cannot be simply separated by a threshold. Refer **Figure B**. Here the chance density of the matching scores real and false attempts are displayed. The light-grey area left of the threshold is the false rejection rate (FRR): the chance that a real user will be rejected because their matching score is below the threshold. The dark-grey area right of the threshold is the false acceptance rate (FAR): the chance that an intruder will be accepted because their matching score is above the threshold. By adjusting the threshold, the chance of error can be tuned to the application. A high threshold requires a high degree of similarity between the live measurement and the information stored in the database. Because the FAR becomes lower, the setting is suitable for high security applications. A disadvantage is the FRR (the chance that the real user has to try again to be recognised) has increased. On the other hand, a lower threshold can be selected, so that the FRR will be reduced. This setting is appropriate if user convenience rather than high security is the most important requirement. A disadvantage of this setting is the FAR is now higher, which means that there is a significant chance that unauthorised persons are admitted.

To give a better insight on the relationship between FRR and FAR, they can be plotted as a function of the threshold. This graph is called the receiver operating curve (ROC), refer **Figure C**.

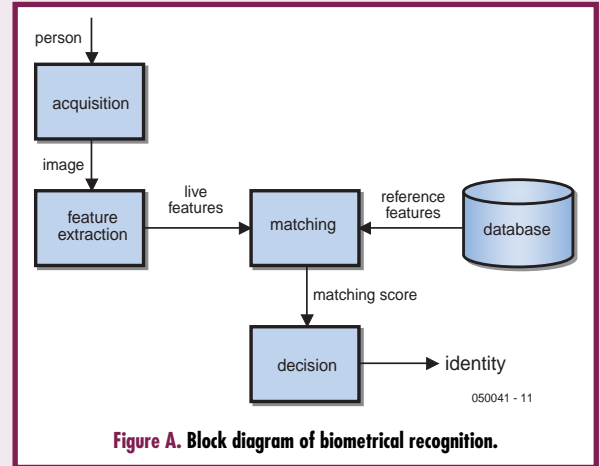

Figure A. Block diagram of biometrical recognition.

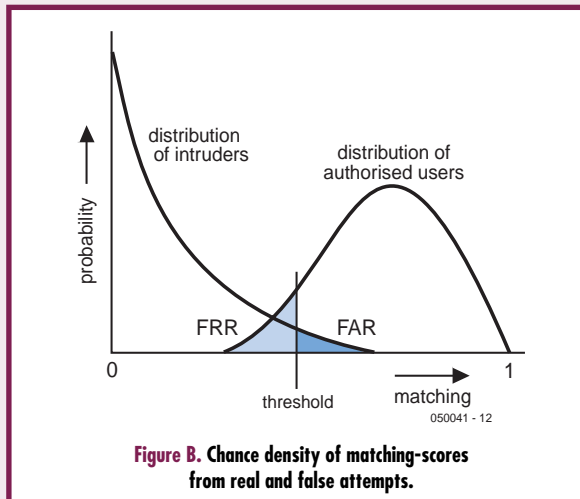

Figure B. Chance density of matching-scores from real and false attempts.

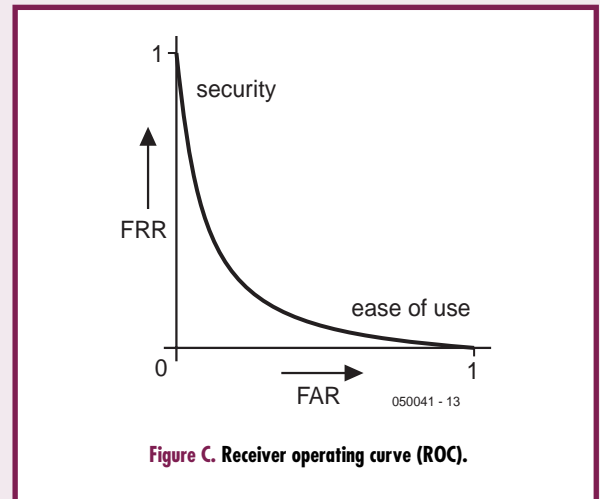

Figure C. Receiver operating curve (ROC).

is placed on the sensor, so that a slightly different part of the print is recorded. This may result in only partially overlapping prints. Thirdly, the system has to deal with rotation, translation and scaling of the prints. The last problem is the non-linear distortion between two prints. These are caused by the recording process itself. During this process, the elastic, 3-dimensional surface of the finger is flattened against the sensor. This flattening is slightly different each time, depending on, for example, the pressure applied and sliding and rotating of the finger while recording. This 3D to 2D mapping of the skin on the finger causes non-linear distortion, particularly when there are forces that are not perpendicular to the sensor surface. This is often the case when uncooperative users deliberately apply a lot of force to prevent recognition.

Because of the aforementioned problems, pictures of fingerprints cannot be compared directly, but use is made of characteristics that are less sensitive to distortion such as the orientation field and minutiae.

In identification systems in particular, the orientation field is used, i.e., the global form. The Henry classification is determined for every print in the database. When a particular fingerprint needs to be matched, only that part of the database with the corresponding classification is searched in order to obtain the highest possible searching efficiency. This method however, has two disadvantages. Firstly, there are only five classes and 90% of all fingerprints fall into only three classes. This means that on average 30% of the database still has to be searched through, which is not that much of a reduction. Secondly there is the risk if incorrect classification, which means that the wrong part of the database will be searched and it is very unlikely that the right fingerprint will be found. An alternative, of course, is to compare prints without first dividing them into discrete classes.

The chances of errors with fingerprint recognition, by the way, are much smaller than those for face recognition. In particular, a very low false acceptance rate (roughly, FAR



Figure 3.
Characteristics of a face: texture and geometry.

= 0.01%) is easily obtainable. It is however, still a challenge to have a low false rejection rate in poor circumstances.

Multi-mode biometry

In order to improve the biometric recognition scores it is possible to make use of multi-modal biometry. Here the recognition is made based on a combination of different biometric measurements. Many different types of measurement can be combined, for example fingerprint and face recognition, such as is used in biometric passports. By combining the matching scores in this way, the chance that both the face as well as the fingerprint of an intruder has sufficient likeness to an authorised person is much smaller than each system on its own. In addition, the multi-modal system is much more robust against false rejection. Furthermore, multi-modal biometry can play an

important role with identification and watch-list systems. Firstly, low error rates are the most important consideration. In addition, one biometric measurement (for example the face) can be used for an initial rough filtering. This can speed up the database search and only patterns that exceed a certain threshold continue through to the next phase where a more complicated and accurate comparison (for example minutiae of a fingerprint) takes place. As the requirements for biometric recognition increase, multi-mode biometry will play an increasingly important role.

(050041-1)

Solution to Figure 2: If you look very closely at the details, you will see that the two photos on the right are from the same person while the left photo is from a different person.



Figure 4.
Henry-classification: whorl, right loop and arch.

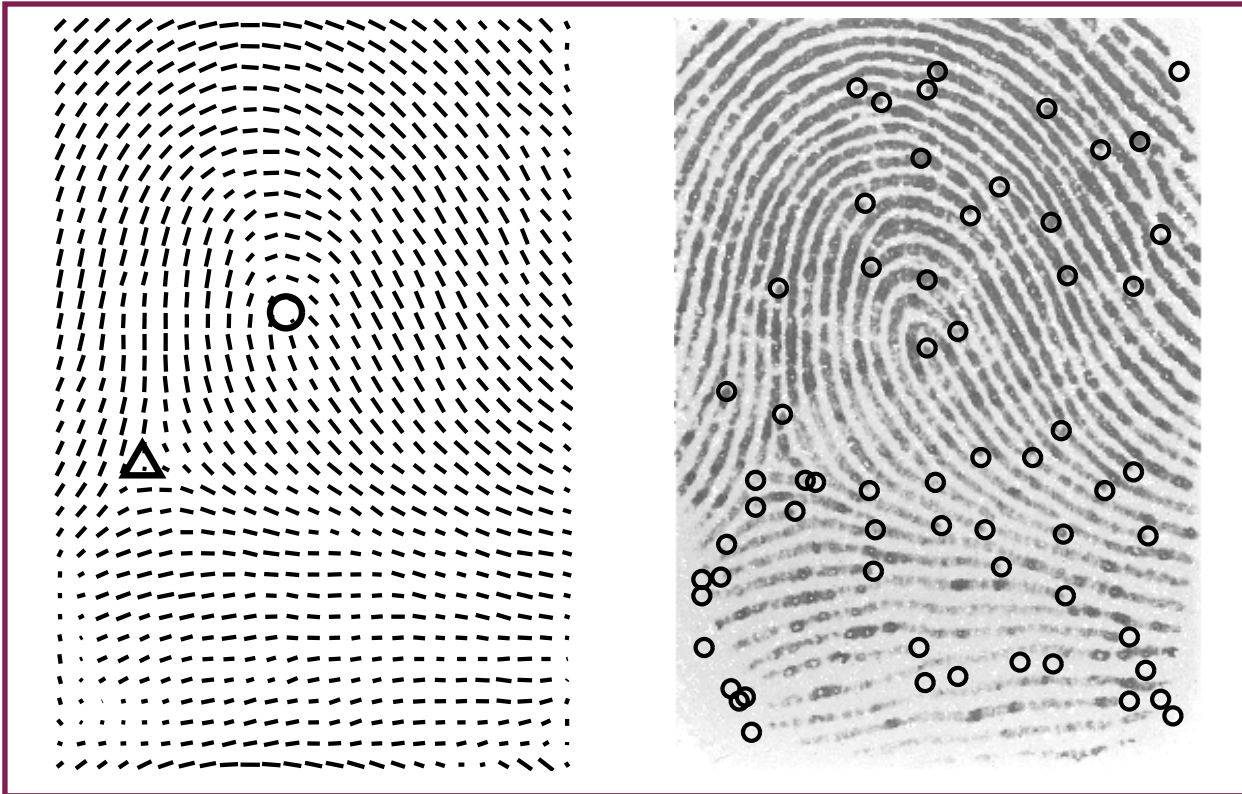

Figure 5.
Orientation field
and minutiae of a
fingerprint.

Types of system

In principle, biometry can be used in three different ways, namely verification, identification and as a watch-list system. In all these cases there is first an 'enrolment' procedure where the reference data of registered users are stored.

Verification, which is also called one-to-one matching, is the simplest form of biometric recognition. The user first indicates who they are, for example by supplying a smart card or username. This information is used to retrieve the reference data from the database. Then, a new biometric measurement is made of the user, which is used to verify the identity by comparing with the reference data. In a verification system the reference data can be stored in a central database or, for example, smartcards that users carry with them (distributed database). This last solution is preferable from privacy considerations: the biometric data is only available when the user agrees.

In an identification system, also called one-to-many matching, the user does not need to claim any identity. In this case, the system makes a biometric measurement and this measurement is compared with all information in the database. As soon as a record has been found that matches, the user has been identified. An advantage of identification is the user-friendliness; users need not carry around a card or have to type in a username. The problem however, is that recognition is a much more complicated task for the biometric system. Using present day techniques this method is not suitable for applications such as access control.

A watch-list system contains a list of biometric characteristics of persons that have to be recognised. This could be people who do not have access to a certain area or service. In most situations these people will not announce themselves, so the system has to work on the basis of identification. You can also not assume that the persons of interest will cooperate with the system when making a good biometric measurement, which makes the application of the system rather complicated. In addition, the role of the error chance has been reversed. Now a missed detection (FRR) leads to a security risk, while a false alarm (FAR) leads to inconvenience. The focus is therefore a low FRR, while the users themselves will try their best to obtain an FRR as high as possible. An even more complicated variation is watch-list surveillance. This application is even more difficult than a standard watch-list, because fingerprints cannot be used, but only images taken from a distance. Biometric surveillance is currently not quite achievable, unless use is made of extremely well controlled circumstances.

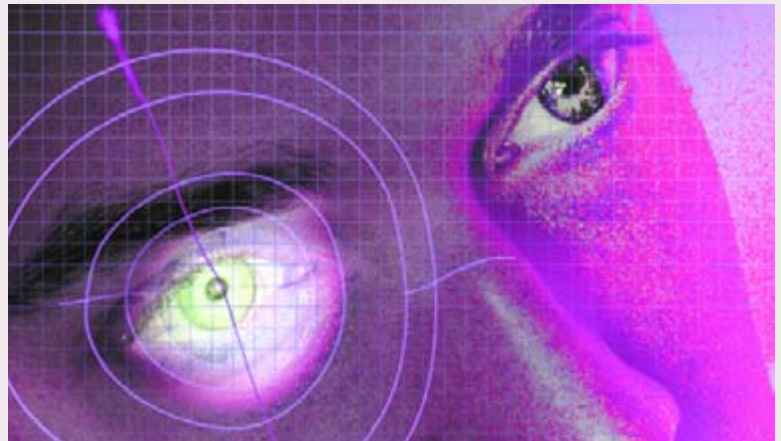

Fingerprint as P

Fingerprint-based authentication: how it works

Helmut Lemme

Electronics comes to the rescue again: is the person using a machine really who they say they are? Passwords have not shown themselves to be a foolproof form of identification, and the trend is now towards biometric methods, including fingerprints, becoming more widely used. We look at how fingerprint sensors work and at the advantages and disadvantages of the various techniques.

Falsification of e-mails, attacks from viruses, theft of laptops and mobile phones: these are some of the less desirable consequences of the growth in information technology. PINs and passwords give some protection, but remembering and keeping track of a different code for each machine is a problem in itself. Little better are smart cards: if you lose your card, you can almost cease to be a member of society.

It would be logical, then, to use some identifier that cannot be lost, changed or falsified. Biometric techniques take advantage of the fact that the characteristics of the human body are unique and fixed. Facial features, the pattern of the iris, handwriting, fingerprints and others are used: even including DNA.

For day-to-day use we need to look at what is practical and cost-effective. The most popular technique is the use of fingerprints. In the past, an ink pad and paper were used, the print then being laboriously compared with templates by eye. The first research into electronic methods began in the 1970s, and the techniques came into practical use in the 1990s. The first systems were not particularly reliable and were easily deceived. The more modern sensors are much better. There are already millions in



assword

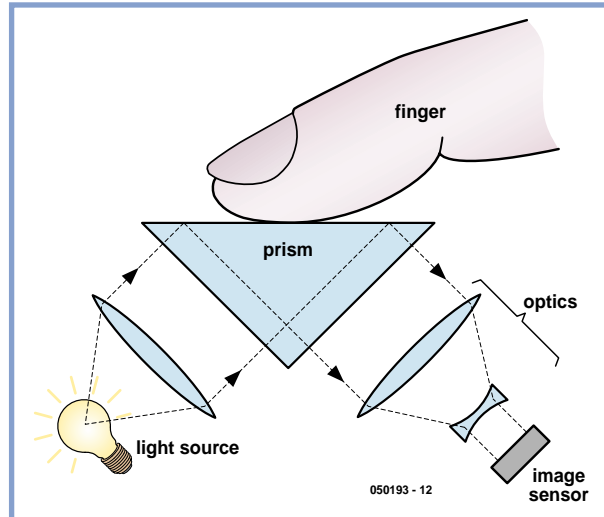

Figure 1. The earliest technique for capturing fingerprints is this optical arrangement with an image sensor. (Source: Parrain/Tima)

use, and thanks to falling prices, they are continuously finding application in new devices. The probability that an impostor will be accepted (false acceptance rate, or FAR) is exceptionally low; the probability that the true user will not be recognised and thus denied access (false rejection rate, or FRR) is also low.

The requirements for this type of sensor are as follows:

- minimal FAR and FRR;
- secure against deception;
- physical size as small as possible for use in portable devices;
- minimal current consumption;
- robust and durable;
- capable of economic mass production.

Silicon chip-based sensors satisfy most of these requirements.

A wide range of techniques

There are so many developments in this field that it is hard to summarise them all. The sensors can be grouped according to a few different operating principles: we will look at the most important.

Reflective optical sensors: This is the oldest technique. The finger is placed on a glass plate or a prism and illuminated by a LED. Where the ridges of the finger touch the surface, the light is absorbed; in between there is total reflection. The resulting light and dark areas are registered on an image sensor (CCD or CMOS): see **Figure 1**. In practice there are difficulties with this technique: the images obtained with wet and dry fingers are very different, and furthermore, the system is sensitive to dirt on the surface. The unit is large in size, unreliable and expensive. It is also easy to deceive: see the text box. If the skin is worn or damaged the print is often not recognised well. Recognition of the fingerprints of older people is also difficult, since the skin is not elastic enough. In some circumstances this can result in false recognition. If the template print is taken with less force, false acceptances can occur.

Transmissive optical sensors: This technique operates without direct contact between the finger and the surface of the sensor. In one device made by Mitsubishi light is shone through the finger from the nail side, and

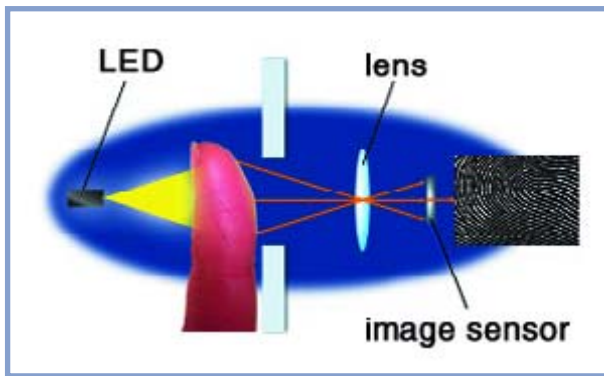

Figure 2.
Illumination through the finger makes the system harder to defeat.
(Source: Mitsubishi)

a camera takes a direct image of the fingertip (**Figure 2**). Moisture does not cause any difficulties. Lumidigm uses a more sophisticated approach: measurements are taken using different wavelengths of light. The sensor sees through the surface of the skin into the deeper tissue and produces a multispectral image. The use of different wavelengths to generate images brings out different subcutaneous structures: a good indication that the object in question is a genuine finger! The use of orthogonal polarising filters ensures that only light that has undergone scattering under the skin is passed, and directly reflected light from the surface is blocked. Only very accurate artificial fingers would have a chance against this sensor.

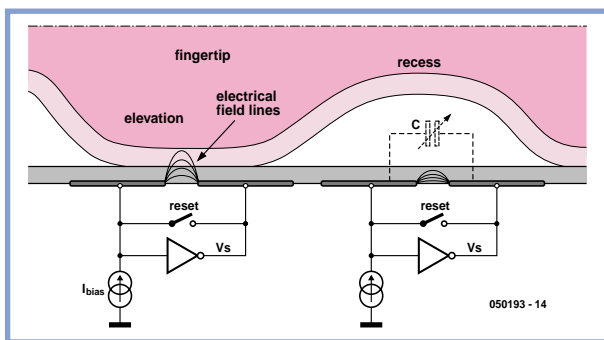

Figure 3.
How a capacitive sensor works: the feedback capacitance is different under ridges and valleys.
(Source: Upek)

Capacitive sensors: The sensor is a silicon chip whose surface is covered by a large number of transducer elements (or pixels), with a resolution of typically 500 dpi. Each element contains two adjacent metal electrodes. The capacitance between these electrodes, which forms a feedback path for an inverting amplifier, reduces when a finger is applied: more so where there are ridges, and less so in between (**Figure 3**). Manufacturers include UPEK and Veridicom (Infineon has withdrawn from this market). There are a few disadvantages to this technique: since the electric field between the electrodes falls off rapidly, the protective layer on the surface must be very thin. The sensor is therefore susceptible to electrostatic discharges. These sensors only work with normal healthy skin; they are not reliable when used on skin with hard areas, calluses or scars. Moisture, grease and dirt can also affect operation. Reliability against deception using artificial copies of fingers is relatively high: the sensor can accurately distinguish the dielectric properties of genuine skin from those of artificial imitations.

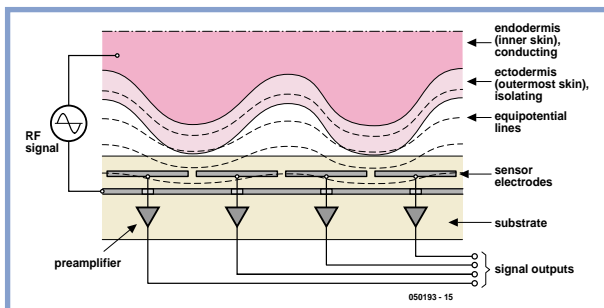

Figure 4.
The high-frequency technique captures the structures in the conductive subcutaneous layer.
(Source: Parrain/Tima)

High frequency sensors: This is a variation of the capacitive technique described above. Each pixel contains only a single electrode. The finger itself acts as the other electrode: more precisely, the electrode is the subcutaneous layer which is a good conductor, and unaffected by grease, drying out, calluses and so on. An outer contact ring couples a weak HF signal into the finger. The amplitude of the signal at each electrode is then proportional to the local coupling capacitance: higher where there is a ridge and lower in the valleys in between. An amplifier with a high input impedance sits directly underneath each electrode (**Figure 4**). In contrast to previous capacitive sensors this technique can detect the ridges and valleys in the living cell layer beneath dead surface skin cells. The voltage and frequency of the HF signal can be adjusted to obtain the best image. It is possible to make these sensors very tiny, which means that they are suitable for use in portable devices such as mobile phones. A further advantage is that because of the approximately uniform electric field the protective layer can be thicker, improving immunity to electrostatic discharge. Dirt is less of a problem too, as the air gap between finger and sensor surface is almost irrelevant. Manufacturers include AuthenTec, Fingerprint Cards, Topaz/IDGem and Toshiba.

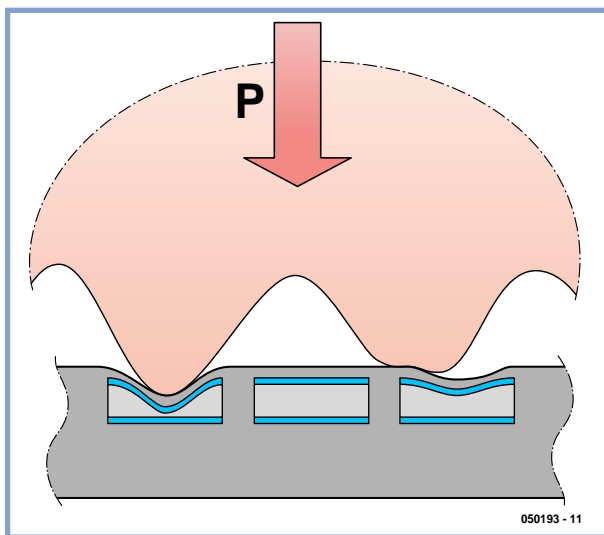

Figure 5.
Principle of detecting lines on the finger using a micromechanical pressure sensor.
(Source: Rey/LETI)

Mechanical: This type of sensor is in the more general class of MEMS (Micro Electro-Mechanical System) devices. In one version developed by the French research institute LETI, tens of thousands of tiny pressure transducers are arranged on the sensor surface (**Figures 5 and 6**). An alternative design uses switches which are

closed when pressed down by a ridge, but remain open when under a valley. This gives only one bit of information per pixel, rather than a grey scale. Alps is one manufacturer of this type of sensor.

Thermal: In this case the sensor detects the heat conducted from the finger, which is greater where there is a ridge than where there is a valley. A leader in this technology is Atmel, who have developed a silicon device with a matrix of pixels (called 'FingerChip'), each covered with a layer of pyroelectric material in which a change in temperature results in a change in surface charge distribution (Figure 7). Each pixel is equipped with an amplifier which takes the signal to the readout circuitry. A grey scale image is produced which has adequate quality even with worn, dirty, greasy or moist fingers. The sensor has a robust protective layer and can give dynamic output.

Dynamic output: Many of the sensors described have been subverted in the past (see text box). To avoid this, a new mode of operation is added. Rather than simply placing the finger statically on the sensor, it is slowly dragged across it. The sensor has only a narrow sensitive area (Figure 8), and generates an entire sequence of images, which the processor can then reassemble into a complete picture (Figure 9). Reliability is greatly improved, and any residual grease is guaranteed to be removed. Several manufacturers produce such sensors, including UPEK and Fingerprints.

Feature extraction

The story, however, does not end at the sensor. Initially the captured image will be in a raw format; little can be done with this as it stands, as it requires a lot of memory to store it. Comparing a print with many other images on this basis would require a lot of computing power. Instead, we extract some features from the image. Let us look more closely at a fingerprint: the basic classification is into the arch, the loop and the whorl. Particular features within the pattern include ridge ends, bifurcations, crossovers, lakes and dots — collectively called 'minutiae' in the jargon. Obtaining the orientation and position of these is enough to give a clear characterisation (Figure 10). About 10 to 20 minutiae suffice to make a reliable decision. The reduced data set (or 'template') is many orders of magnitude smaller than the original data, and generally less than one kilobyte. It is only this data set that the computer must compare, and so a large number of comparisons can be carried out quickly. The processing also removes the effect of translations and rotations of the image. Much software has been developed for this task: an almost innumerable range of different approaches have been taken.

A flood of applications

The most important application area is in access control for computers. This is especially important for laptops and PDAs, which are frequently stolen. For example, the iPAQ hx2750 from HP, the Acer Travelmate 739T1V and the IBM T42 ThinkPad all offer built-in fingerprint sensors. Thanks to falling prices more and more devices are being fitted with sensors, in particular mobile phones including models from NTT Docomo, Fujitsu, Pantech and LG. Some models can distinguish between up to ten different fingerprints, so that the device can be used by several

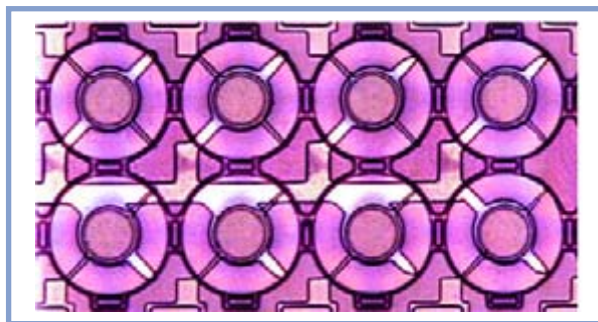

Figure 6. The integrated pressure sensor under the microscope. The external diameter of the sensor elements is 45 µm, and the diameter of the elastic membrane is 25 µm. (Source: Rey/LETI)

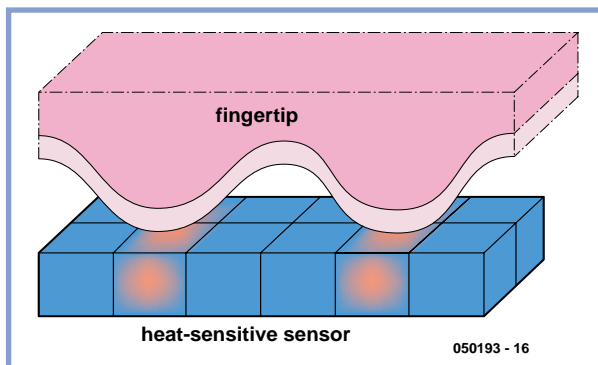

Figure 7. Principle of a thermal fingerprint sensor. The electric charge on the pyroelectric element in each pixel changes with temperature. (Source: Parrain/Tima)

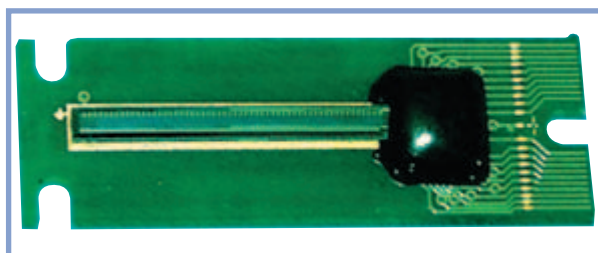

Figure 8. The dynamic technique, where the finger is dragged over the sensor, can use a very narrow sensor area. (Source: Atmel)

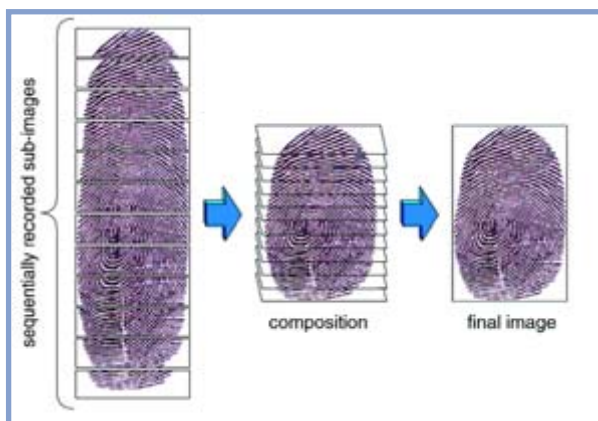

Figure 9. A dynamic sensor produces a sequence of individual sub-images which the processor can reassemble into a complete image. (Source: Parrain/Tima)



Figure 10. The so-called 'minutiae' are particular points on the finger ridges such as bifurcations and crossovers. To compare prints it is sufficient to record the position and orientation of each. (Source: Fidelica)

Can the systems be outwitted?

In the early days of this technology defeating the system was relatively easy. The earliest idea was to reactivate the traces of grease left behind on the sensor surface by a genuine user. By breathing on the surface, fine droplets of moisture remain which make the print clearer. Some sensors using optical principles have been defeated in this way. The dynamic technique was introduced to combat this: the finger is not left statically on the sensor, but dragged slowly across it. This ensures that old traces of grease are removed.

A second approach is to apply a copy of the fingerprint. As is known, people leave fingerprints behind everywhere. Taking copies of these is a well-known process used by the police. Fine graphite powder sticks to the traces of grease and these can be lifted off using adhesive tape and photographed or scanned into a computer. They can then be printed onto paper or transparency film using a laser printer. This can be used to defeat an optical sensor: even a dynamic one. Capacitive sensors can also be defeated in this way if the toner film is thick enough.

A third technique is to construct an artificial finger with the lines of a real one. Using silicone rubber it is possible to mould objects with exceptional precision and capture precise details. Sensor manufacturers are of course wise to these tricks, and have taken countermeasures against them. Optical sensors capture images under illumination of various different wave-lengths; capacitive sensors accurately analyse the dielectric properties of the object on the sensor surface, and high frequency sensors analyse the structure of the deeper subcutaneous layers.

The software is also becoming more and more reliable. A wide-ranging study conducted by the German Federal Office for Information Security in 2004 found that the systems gave good security.

different people. The Pantech model includes 'secret finger dial' where up to ten short codes can be dialled by putting the appropriate finger against the sensor. Other devices with built-in fingerprint sensors include USB hard drives (from LaCie), USB memory sticks (from Dr Fehr GmbH and RiTech International Ltd) and card readers (from Comix). These allow data to be stored securely. Securable mice (the Cherry M-4000D ID Mouse Professional) and keyboards (Key Source International) are also available.

The sensors will increasingly be used for securing financial transactions at cash machines and for on-line banking. In the future the fingerprint of the owner will be securely stored in identity cards and credit cards, and they will also be used for authenticating e-mails using digital signatures.

Direct physical access to rooms and devices can be ensured by coupling fingerprint sensors with door openers. Departure terminals in airports will be able to

process passengers more rapidly. Cars, construction machinery, boats and aircraft will also be protected against theft.

The long-term view

The market is growing rapidly. In a few years the fingerprint systems market will be worth billions. Data protection advocates warn of a Big Brother society, but this is already with us: the widespread use of fingerprint sensors will not make the overall situation significantly worse. The minutiae of the fingerprint cannot be regarded as being as private as the details of one's bank account or medical record. If the minutiae should fall into the wrong hands, the recipient suffers from the immediate disadvantage that it is not possible to reconstruct the entire fingerprint from them. In any case this technology will do more to make criminals' lives harder than it will cause inconvenience to their honest fellow citizens.

(050193-)



A combination of fingerprint sensor and smart card can give even greater security. It is very hard to analyse what is going on in the processor. (Source: Upek)



A fingerprint sensor next to a door can be used to control access.

FREE Layout Software

EASY To Use!
Very **LOW** Cost!
Extremely **FAST**
Turnaround!

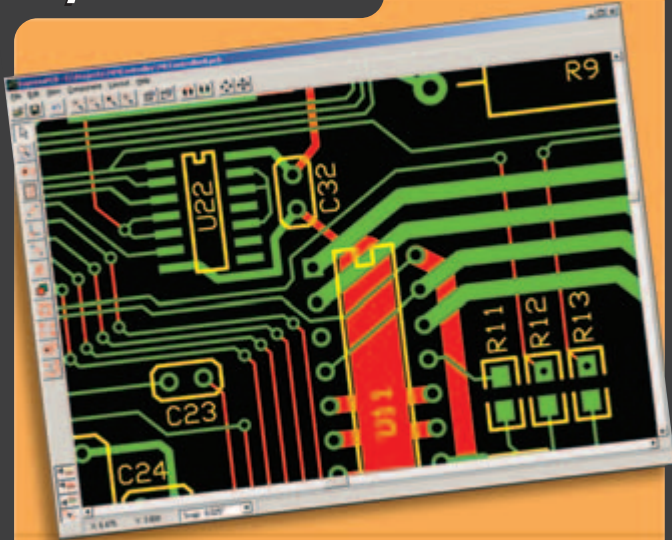

- 01 **DOWNLOAD** our free CAD software
- 02 **DESIGN** your two or four layer PC boards
- 03 **SEND** us your design with just a click
- 04 **RECEIVE** top quality boards in just days

expresspcb.com

Total Telematics Control The World

Automation
PIC Technology
Standard Modules
Custom Design & Build



Ethernet uController

PIC18F452 CPU, 24LC256 EEPROM and demo Web Server.
32KBytes FLASH, 1536 Bytes SRAM and 32Kbytes EEPROM.
Web Server uses about half the available EEPROM memory,
heaps of space left for custom web pages!

Server based on the excellent Microchip TCP Stack.
13 user programmable I/O pins, 5 can be Analog Inputs.
LED's indicate Power, Collision/Link, Rx/Carrier, Tx.
RS232 interface via 3 pin connector or Front End connector.
Cable Included for connection to PC or DTE Device.
Has an ICSP (In Circuit Serial Programming) connector.
Full Technical and Programming Documentation.

Pay us a visit
Loads of uController and Automation kit
www.total-telematics.com

OBD CABLES.COM

Thousands of OBD cables and connectors in stock
Custom cable design and manufacturing
Lowest prices · Online ordering · Ship worldwide
Contact us online:

www.OBDCables.com · sales@obd2cables.com



If we don't have your OBD cable, we can help you find it!

Your price conscious PCB supplier



Online Price calculation
Online Ordering
Online Order tracking
Online 24/24H and 7/7D

Verified

- pooling for prototypes and small series
- from 1 till 1.000 pieces
- from 4 working days onwards
- up to 6 layers

à la carte

- wide range of technological capabilities
- up to 20 layers
- from 1 piece onwards
- from 2 working days onwards

MEGApool

- pooling for series
- 250, 500 or 1.000 pieces
- medium series at prices of MEGA series

www.eurocircuits.com

Forest Electronics - PIC and AVR C Compiler Products

FED's ANSI C Compiler for PIC or AVR processors

- Fully integrated editor with syntax highlighting, multiple pages etc.
- Full project support - include and manage multiple source files, simulator, assembler files and notes/comments within one project
- Fully integrated simulator and waveform analyser step from C line to C line, or examine code in assembler form. View device pins using a logic analyser application.
- Simulator supports LCD modules, keypad, buttons, LED's, displays, analogue inputs, serial and asynchronous data and more.
- Designed to ANSI C standards
- PIC - Supports 18xxx, 16xxx, 12xxx series 14 and 16 bit core processors
- AVR - Supports standard and MEGA core processors
- Generates MPLAB/AVR Studio projects and source files and completely standard hex output files.

WIZ-C / AVIDICY

Drag and Drop rapid application development using ANSI C for PIC and AVR

- Rapid Application Development for the PIC or AVR microcontroller using the C language (WIZ-C for the PIC, AVIDICY for the AVR)
- Drag and drop your software component selections on to your design
- Included components support timers, serial interfaces, I2C, LCD, 7 Seg displays, keypads, switches, port controls, many bus interfaces including IIC and Dallas iButton, AVR/PIC Hardware, and more.
- Connect software components to MCU pins by point & click
- Parameters set from drop down list boxes, check boxes, or text entry
- Links your code automatically into library events (e.g. Button Pressed, Byte Received etc.)

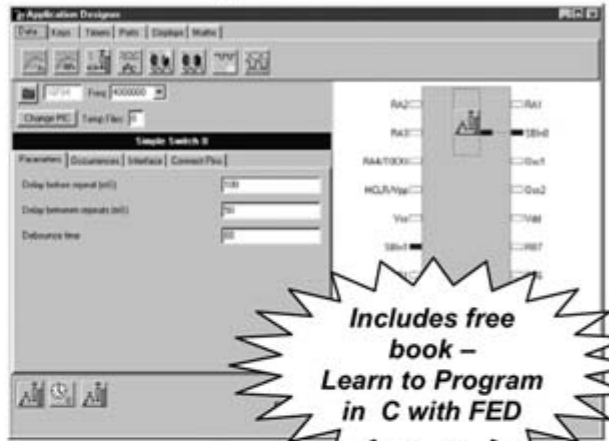

Includes free book - Learn to Program in C with FED

- Automatically generates your base application including full initialisation, interrupt handling and main program loop
- The complete C Compiler and AVR Simulator programs are integrated into AVIDICY - total editing / compilation / assembly / simulation support in one program
- Also includes the Element Editor to enable you to create your own components with ease.
- Demonstration available from our web site

Prices from £45.00 - details & demo from www.fored.co.uk



Forest Electronic Developments
01590-681511 (Voice/Fax)

email : info@fored.co.uk



www.fored.co.uk

Also programmers, ICE, & development systems



Order now using the Order Form in the Readers Services section in this issue.

Elektor Electronics (Publishing)
P.O. Box 190
Tunbridge Wells TN5 7WY
ENGLAND
Telephone +44 (0) 1580 200 657
Fax +44 (0) 1580 200 616
Email: sales@elektor-electronics.co.uk

ELEKTOR AUDIO BOOKS 3 must-haves for all audio-enthusiasts!

Build your own Audio Valve Amplifiers

To many people, the thermionic valve or electron tube is history. However, whether it is nostalgia, interest in the technical parameters, the appeal of a gleaming amplifier chassis with softly glowing valves or perhaps the firm conviction that the sound of a valve cannot be bettered, it is a fact that the valve is making a come-back. This book contains, apart from construction projects for preamplifiers, power amplifiers, and amplifiers for musical instruments, information on the operation of electron tubes, while the first chapter gives a short history of the valve.



ISBN 0 905705 39 4
253 Pages
£15.55 (US\$31.00)

Modern High-end Valve Amplifiers

Valve amplifiers are regarded by many to be the ne plus ultra when it comes to processing audio signals. The combination of classical technology and modern components has resulted in a revival of the valve amplifier. The use of toroidal-core output transformers, developed by the author over the past 15 years, has contributed to this revival. This book explains the whys and wherefores of toroidal output transformers at various technical levels and offers innovative solutions for achieving perfect audio quality.



ISBN 0 905705 63 7
264 Pages
£25.95 (US\$52.00)

Build your own High-End Audio Equipment

The name high-end equipment is a good indication of the prices charged for it. For those who cannot, or will not, pay these high prices, there is a solution offered in this book: build your own at considerable cost savings. This book is aimed not only at this sector of the market, but also at the many enthusiasts who want to be able to experiment and to make their own modifications to their high-end equipment. Contents include solid-state and valve preamplifiers and power amplifiers, active cross-over filters, an active subwoofer, a headphone amplifier and more.



ISBN 0 905705 40 8
262 Pages
£15.55 (US\$31.00)

BitScope

Analog + Digital

100MHz Digital Oscilloscope

Dual Channel Digital Scope using industry standard BNC probes or analog inputs on the POD.

40MS/s Logic Analyzer

8 logic, External Trigger and special purpose inputs to capture digital signals down to 25nS.

Mixed Signal Oscilloscope

True MSO to capture analog waveforms time-aligned with logic using sophisticated cross-triggering on any input.

Real-Time Spectrum Analyzer

See spectra and waveforms in real-time displayed simultaneously

Waveform Generator

Load up to 128K arbitrary waveform and replay via BNC B. Capture circuit response simultaneously on BNC A

PC Oscilloscopes & Analyzers

Get the full picture with BitScope Mixed Signal Oscilloscopes



Turn your PC into a powerful Digital Storage Oscilloscope!

See inside your circuit with simultaneous analog, logic and spectrum displays to make tracking down those elusive real-time bugs much easier.

BitScope combines a high speed synchronized storage scope and logic analyzer with a programmable waveform generator and spectrum analyzer.

With "Smart POD" connected active probes and multiple software options you've got the perfect low cost high performance test and debug solution!



Standard 1M/20pF BNC Inputs

200uV-20V/div with x10 probe
S/W select AC/DC coupling
Switchable 50ohm termination
Arbitrary Waveform Generator

BitScope Smart POD probe connector

8 logic channels, cross-triggering
Dual channel analog inputs
Async serial I/O for external control
Supports active probes

USB 2.0 or Ethernet Connectivity

Single cable to PC or switch
Compressed data transmission
Ethernet option uses UDP/IP
Internet addressable device

Expandable and Programmable

Simple ASCII Protocol
BitScope Scripting Language
Add active probes and devices
Supplies up to 500mA via POD

BitScope and your PC provide an array of Virtual Instruments

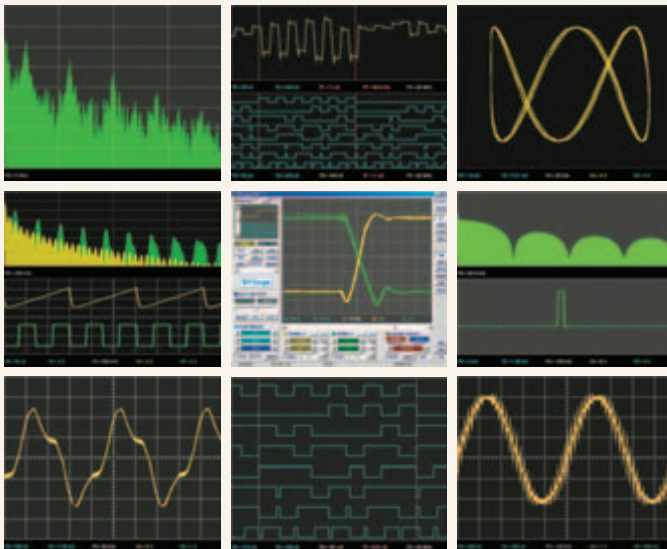

BitScope DSO software for Windows and Linux

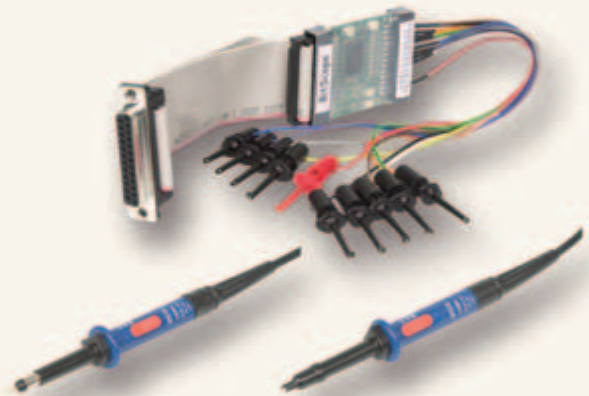

BitScope's integrated design uses standard oscilloscope probes and a growing range of custom probes to provide functionality equal to instruments many times the price.

BitScope plugs into third party software tools and has an open API for user programming and custom data acquisition.

www.bitscope.com

Fingerprint S



for dedicated

The article on fingerprint authentication elsewhere in this issue describes the wide array of different incarnations and applications of these interesting devices. We now look at whether it is possible in practice to for an enthusiast to use one in a project. What devices are available for purchase, and how difficult are they to use?

The catalogues of the major electronic component suppliers are generally silent on the subject of fingerprint identification. A Google search on the Internet gives rather different results, however: there is a large amount of documentation and other resources and there is a splendid array of suppliers of starter kits,

SDKs (software development kits) and other support for developers. There are also various products which include fingerprint sensors, such as door openers and closers (from around £ 300), keyboards and mice with built-in fingertip sensors (from about £ 30). However it is difficult to find the individual sensors

themselves for use as a component in a project. One one-off price we did manage to obtain for the Fujitsu MBF sensor was in the region of £ 50.

Experimentation

The cheapest way of obtaining a fingerprint sensor is therefore to get hold

sensors



applications

of a ready-made fingerprint scanner for use with a PC. A typical example of such a device is the Microsoft fingerprint reader with a USB connection, available for around £ 40. For a few pounds more the reader can be obtained in combination with a PC-compatible mouse and keyboard.

As the photo (**Figure 1**) shows, we apparently have an optical fingerprint sensor. The sensor surface is illuminated from the side by red LEDs and although it is fully transparent, it is not hard and shiny like perspex but rather elastic and matt like silicone rubber or soft PVC, so that the finger leaves no visible print behind. This should not necessarily be interpreted

as a security measure by the manufacturer, as Microsoft warns in the installation manual that the sensor is intended to be used to simplify the logging-in process rather than to increase security. The fingerprint reader is used in conjunction with the supplied (Windows XP-compatible) software ('DigitalPersona Password Manager') to provide the password when starting Windows XP and other programs, as well as when logging on to web sites. Microsoft recommends that the reader is not used to control access to company networks or to protect sensitive data.

Before using the fingerprint reader the software must be installed and the tips of at least two fingers must be registered as a reference. This involves scanning each fingertip four times. **Figure 2** shows the fingerprint registration wizard after two fingers have been registered.

In practice the fingerprint reader was found to be surprisingly reliable, despite the security warnings of the manufacturer. The registered fingertips were recognised without noticeable delay. Non-registered fingertips were rejected almost as quickly. There were no false rejections or acceptances. The fingerprint reader is thus entirely suitable for the purposes suggested by the manufacturer. Could it also be useful in other applications (which, considering its price, would be interesting)? The answer seems to be no. The reader connects over a standard USB interface, but there is no documentation accompanying the software and reverse engineering it looks like a tough proposition. If, on the other hand, we use the supplied software, we need a complete PC running Windows XP in order to carry out some function such as opening a door. We also have to bear in mind that Microsoft claims that the product is not secure.

Development

As can clearly be seen in the arena of mobile phones, powerful technology can be manufactured cheaply if the quantities are great enough. This goes for fingerprint sensors too. For low-volume applications it is not only the sensor elements that are costly: the same goes for the accompanying software and hardware required. Processing and, more importantly, evaluating the

sensor output requires a relatively high level of processing power. Even in stand-alone applications such as for example a 'simple' door lock we need a high-end microcontroller (a 32-bit RISC such as an ARM7 or ARM9, or a DSP) in order to detect fingerprints reliably. The software development is also a complex process, and the cost of this is built into the prices for SDKs and licences. A development kit is not suitable for our first steps, since it will cost at least a few hundred pounds. In **Table 1** we give a (surely incomplete) overview of the kits available for stand-alone applications.

The Atmel and Fujitsu kits include modules which appear to be suitable for real applications rather than just for development. The Atmel module is available to order without the kit (but including licensed recognition software), whereas the Fujitsu module is not available separately. Instead, it can be used as a reference design as part of a dedicated application, and the fingerprint recognition software can then be licensed separately.

The FS Forth-Systeme GmbH kit is based on a standard development board; the TI Development Tool takes the form of a daughter card for a DSP board (from a DSP starter kit). TI has a range of four such daughter cards with fingerprint sensors from Atmel, AuthenTec and Fingerprint Cards. The compatible DSP boards are shown in the table.

A closer look

We will now take a closer look at the Fujitsu starter kit: we would like to thank the distributors Glyn for supplying us with a sample. The MDFP200-EDK 'Embedded Fingerprint Development Kit' includes a complete development environment and software library for autonomous fingerprint verification. The software is delivered on the MDFP200-EDK support CD (version 1.2). The hardware consists of a module and three printed circuit boards stacked on top of each other (**Figure 3**). The top printed circuit board is fitted with an MBF200 large area sensor. This is a very thin capacitive sensor (just 1.4 mm high) manufactured in CMOS technology. The array is 256 by 300 pixels, giving a scan resolution of 500 dpi. Below this board is a Fujitsu FR-series MB91302 32-bit RISC microcontroller with 8 MB of SDRAM and

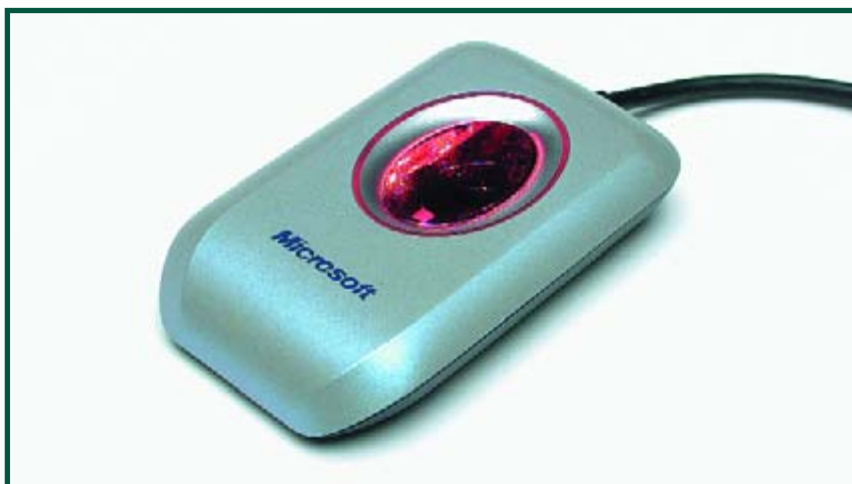

Figure 1. The Microsoft fingerprint reader, with USB interface, uses an optical sensor.

2 MB of flash memory. A mains adaptor is also supplied, along with two cables for connecting the two RS-232 interfaces of the module with the serial ports of a PC. The module also offers a relay output which can be used, for example, to operate a door opener. A buzzer and LEDs are available to indicate the results of the verification process, and buttons and a switch allow the user to control the functions of the unit. The hardware documentation on the kit CD supports the use of the hardware as a reference design for dedicated applications. Data sheets for the individual components as well as printed circuit board layouts, circuit diagrams and parts lists for the module are also included.

The applications software includes a driver library for setting up and controlling the sensor and for reading in fingerprint data. A software library from Ikendi is available to verify a fingerprint by comparison with templates, based on minutiae analysis. The licence is restricted to use with the starter kit. A flash utility allows new applications software and a bootstrap program to be downloaded.

The software CD also includes Fujitsu's Softune Workbench, a complete development toolchain for the microcontroller including compiler, assembler and linker. On-line registration is required before it can be used. When the CD is inserted a web browser starts up at an HTML contents page that allows access to the various options. If Windows XP with service pack 2 is used, there will be a warning regarding web pages containing active content.

Particularly pleasing is how quick it is to set the module up. A short demonstration programme allows an immediate test of the fingerprint sensor, which works without problems and which even tolerates fingertips presented at angles of up to 45 degrees.

Comparison

The same Fujitsu MBF200 sensor is used in the SPF200-USB-Eva kit from Fujitsu that we have included in our tests for comparison. This test kit (Figure 4) includes a ready-to-use USB fingerprint module type SPF200-USB and a demonstration version of the myMinutia verification software, which offers various interesting pos-

Fingerprint starter kits for stand-alone applications

Manufacturer /distributor	Part number	Sensor	Processor	Software
Atmel	AT77SM0101BCB02VKE biometric module	Atmel AT77C101B-CB02V	ARM9 (AT91RM920)	Linux/Ikendi
Fujitsu/Glyn	MDFP200-EDK	Fujitsu MBF-200	Fujitsu MB91302 (32-bit RISC)	C/Ikendi
FS FORTH-SYSTEME	Developer's Kit IKENDI for LxNETES	Fujitsu MBF-200 (option: Authentec)	ARM7TDMI	Linux/Ikendi
Texas Instruments	FADT	Atmel/Authentec/FPC	TMS320C5510/TMS320C6713 (DSPs)	FPC/Bioscrypt



Figure 2. The fingerprint registration wizard after the prints of two fingers have been registered.

sibilities. For example, 'live video' can be fed from the sensor directly to the screen and the comparison algorithm can be watched in action (Figure 5). A few program examples are available on the CD to help in the development of dedicated PC software, but further software (for example Microsoft Visual C/C++ 5.0, along with header and library files and runtime DLLs for Veridicom's SDK) is required to compile it.

It was interesting to compare this device with the MDFP200-EDK development kit described above, which used the same sensor but with different software and hardware. The same sensor in the USB module was much more sensitive to residual grease from previous fingerprints. It also had some difficulties in scanning, being unable to generate reference templates for some fingertips. Turning the fingertip when applying it to the sensor was not tolerated. As we can see, the quality of the results depends substantially on the software and on how the device is set up and adjusted.

Conclusion

Anyone interested in stand-alone applications for fingerprint sensors can get results relatively quickly using a starter kit. There are considerable technical complications, and for low-volume applications costs can also be significant. The price of the Fujitsu development kit we tested here is around £ 300 plus VAT.

(050193-2)

With thanks to Michael Ehlert at Glyn, Andreas Riedenaer at INELTEK Mitte GmbH and Dr. Klaus Sander at Sander Electronic for their support and for supplying documentation.

Reference :

Davide Maltoni et al.,
« Handbook of Fingerprint Recognition »,
Springer, Berlin 2003 (includes DVD).



Figure 3. Fingerprint module from Fujitsu with powerful 32-bit microcontroller for autonomous applications.



Figure 4. Evaluation kit with USB fingerprint module.

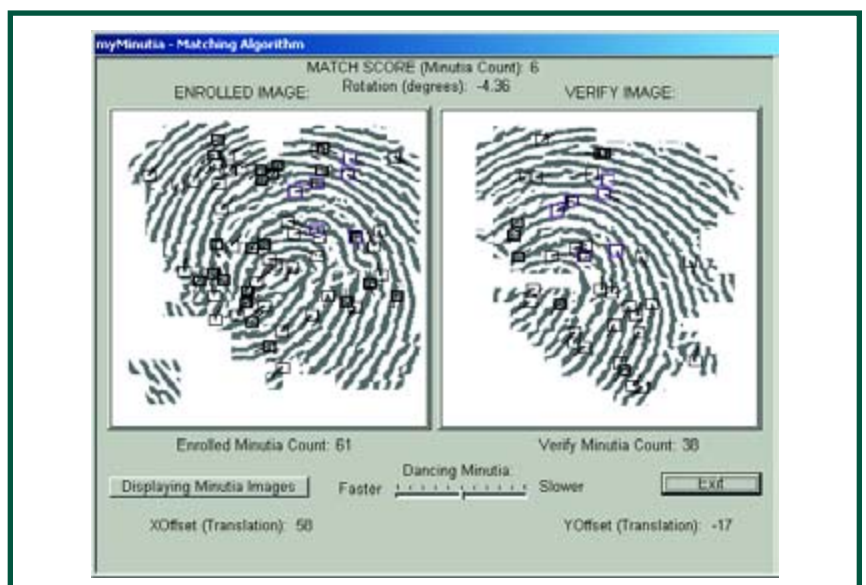

Figure 5. The myMinutia software compares the reference template (left) with the print being verified (right).

Colossus Jr.

A data authenticator

Mike Simpson



Cryptography is usually thought of as concerned only with keeping secrets, but there is another use for cryptography, which has more to do with keeping things in the open. This other use, which rightly belongs in this issue on All Things Security, is data authentication: techniques for verifying that data has not been tampered with.

Where financial decisions depend on recorded data, there is an incentive to falsify it. Falsification of data may disguise an embarrassing oversight or just make a report more readable; it may gain a lucrative contract or hide a fatal error. Keeping data secret is a poor choice, as it may be needed to make day to day or even minute by minute decision in the field.

The device presented in this article is a data authenticator. It takes data which has been gathered by a data logger and checks an authentication code which was generated by the logger in order to verify that the data has not been changed. A typical system that would benefit from data authentication is shown in **Figure 1**.

Changing or moving a single character will give a different code, which can not be generated without knowing a key-code that is inaccessibly hidden on the logger and the authenticator. The authenticator is called "Colossus Jr." in honour of Tommy Flowers and the oth-

ers at Dollis Hill GPO Research Labs who during WW2 built an early digital computer of that name to crack the Nazi cryptographic codes used on, among others, Lorenz cipher machines (including several versions of the Enigma).

60+ years on... PIC time!

To build our Colossus Jr., it wasn't necessary to use a large or powerful microcontroller: there are only two outputs and one input, while the code fits into less than 1000 words of program. The only consideration that is not found in the basement level microcontrollers is that an interrupt was needed in order to allow it to read more data while chewing over the last batch. The Microchip PIC12F675 was chosen for this task as it can run at the needed speed while drawing no more current than the DTR terminal on a standard RS232 can afford. Nor are the parts costly or hard to come by — apart from the supporting chips used, just three transistors and a few passive components.



psst....DES encryption

The encryption routines and the actual data authentication implemented in Colossus Jr. are in accordance with the United States National Bureau of Standards Data Encryption Standard, DES. These were written in the late 1970s, partly with the assistance of the spooks of the National Security Agency. The details of how DES works have been a closely guarded secret until recently. I could have told you how they work — but then.....

In sharp contrast to the previous secrecy, the details of their operation are now available on the web, not least on the National Bureau of Standards as Federal Information Processing Standards Publications FIPS PUB 46-3.

Although the DES code can be cracked for encryption if you have large enough "known" and "encrypted" versions of the same data, lots of time and a Very Big Computer, the same doesn't apply to data authentication. Finding a key which works for the data set may be possible but it will only be 1 of 2^{24} (16,777,216) keys which work for that set of data, out of 2^{56} or a whopping 72,057,594,037,927,936 possible keys. Finding one key that works for the original data does not mean it can be used to validate changed data.

For a description of the convolutions used in the encryption engine and for the use of this in data authorization we will leave you to the references at the end of this article. A good in-depth description of the operation of the DES is found in [1], 'The DES Algorithm Illustrated' by J. Orlin Grabbe.

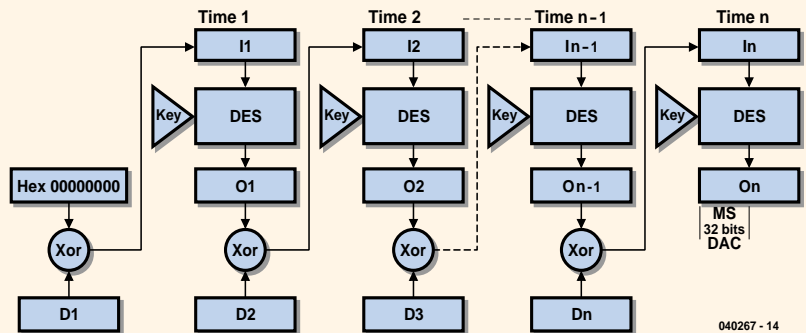

A mini Colossus

The encryption engine code in the authenticator adheres fairly rigorously to the DES standard (see **inset**). We say 'fairly' because one of the tables, known as 'Permuted Choice 1' can be omitted, although the convolutions performed by this will still need to be done, they can be done externally on the original 56-bit key code to generate an internal 64-bit key.

The extension of the DES for purposes of data authentication is covered in FIPS PUB 113, the algorithm is known as the *Digital Authentication Algorithm*, or DAA. Each input block is Exclusive-ORed (XORed) with the output of the last block, the result of this being sent through the DES encryption engine to give rise to the next output

block. The last input block is padded if necessary with null characters (Hex 00) to fill the block and the Data Authentication Code (DAC) is selected from the most significant bits of the final output block.

Our implementation of the DAA differs

most significant 32 bits of the final block (see the example in **Figure 2**).

Practical circuit and use

The circuit diagram of Colossus Jr. shown in **Figure 3** is a far cry from the heavily classified 'blueprints' of its famous ancestor originally designed more than 60 years ago, weighing tonnes and built from relays and thermionic valves. By the way, did you know Colossus has been rebuilt by volunteers and can be seen working at Bletchley Park Museum? See reference [5].

Today, we're dealing with an 8-pin PIC microcontroller weighing next to nothing in just another black-box configuration, i.e., *minimum hardware, maximum software*.

a microcontroller without on-silicon serial support can still communicate at high speed through 'bit-bang' techniques

from FIPS PUB 113 only in that the 0'th output is a string of eight null characters and the initial data block is XORed with that. This is functionally identical with FIPS 113, but is done to make for a more symmetrical subroutine. The final selection of bits to make up the *Data Authentication Code* (DAC) is the

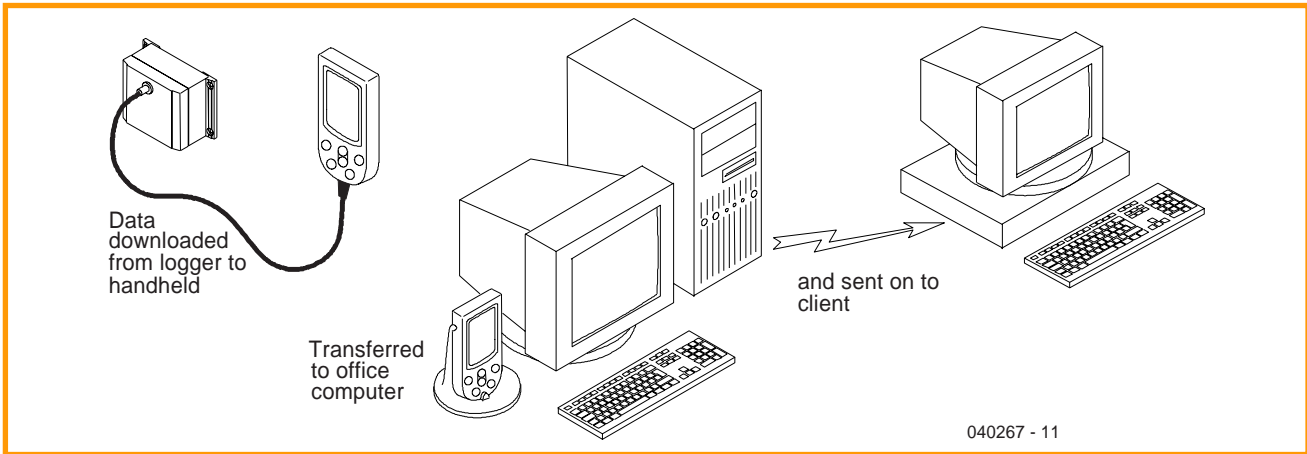

Figure 1. Example of a system that would benefit from data authentication as files are being transferred at least three times between equipment.

The PIC employs its on-board oscillator in combination with an 8-MHz ceramic resonator, RES1. The circuit supply voltage is stolen, via a 7805 regulator, from the DTR line of the PC's RS232 port. The inactive level of DTR (Windows default) is logic '0' or a level between about +10 V and +12 V. In operation the device is connected to an RS232 serial port on a computer via K1 and the file to be verified is sent to the authenticator.

A stop character will acknowledge each block of eight characters received on the PIC unless they have a parity error or a framing error responded to by a 'P' or 'F' respectively. The end of the data file must be marked by an ESC ('escape')

character, after which the authentication code must be sent. This is eight hex digits, 0-9 and A-F that represent a 4-byte code. The circuit will respond to the code with either 'Verified' or 'Rejected' depending on the match.

Building it...

... should also differ vastly from the colossal effort that went into constructing the original deciphering machine during WW2. **Figure 4** shows the tiny PCB designed for the Colossus Junior. Construction is straightforward as no special parts or techniques are used. The 7805 voltage regulator, IC2, can make do without a heatsink. The PIC programming interface is a 5-way single-in-line pinheader; the PC interface, a 9-way sub-D socket for PCB edge mounting. The PIC micro is seated in an 8-way DIL socket. Connect Colossus Jr. to the serial port on your PC by way of a **non-crossed RS232 cable**. The communication program on the PC (like HyperTerminal) should be set to **9600 baud, even parity, 8 data bits, 1 stop bit** (9600,E,8,1).

Key customizing

Open the file 'des.mcp' using MPLAB. You will probably get two error reports which can safely be ignored, so just click on 'OK'. To be able to modify the source code you'll need to open the files 'p1.inc' and 'des.asm' (see also **inset**).

Authorize/Verify selection

Selectt the function of Colossus Jr. in lines 17 and 18 of the file 'des.asm'. For the Authorize (file transmit) function a signature is added by this text:

```
#define Authorize
; #define Validate
```

The other function, data authentication (file reception) is selected by commenting out line 17, so:

```
; #define Authorize
#define Validate
```

Changing the key

You can find the key in lines 15 and 16 of the 'p1.inc' file. Initially this will read

```
PassKeyL = 0x13345779
PassKeyR = 0x9BBCDFF1
```

so the actual key used is: 133457799BBCDFF1

The key needs to be split like this because it's the only way MPLAB can handle 32-bit values.

Compiling and programming

Once the files have been edited to your requirements, you are ready to create a programmer file. In the MPLAB menu, pick 'Project' from the menu and then click on 'Build'. An object code file called 'des.hex' will be created in the

```
>!D
Cycle: 005
Set: 10:04 Saturday 09 November 02
V Facs: 0.03694, 6833, 0.014, 1002
B Facs: 0.01715, 67
Local: Well No. 9, +8.00m
Start: 10:30 Saturday 09 November 02
Period: 00 Hours 30 Minutes

06452, 03524, +12
06452, 03524, +12
06452, 03524, +12
06452, 03523, +12
06452, 03524, +12

06487, 03577, +09
06487, 03578, +09
06487, 03578, +09
06488, 03578, +09
06487, 03578, +09

Readings: 1713 DAC
4FAF821C
040267 - 13
```

Figure 2. Example of an authentication cycle with the DAC (data authentication code) being the 'final word'.

The Windows XP FIFO Buffer

With Colossus Jr. connected to a Windows XP PC you'll find that the RTS/CTS handshaking on the RS232 port will not work very well in combination with the FIFO buffer activity. For proper handshaking with Colossus Jr. this activity has to be minimised or, even better, turned off completely. Here's how to do it. From the Start button, select Control Panels, then System → Hardware → Device Manager → Ports. Right-click on the serial port concerned (e.g., COM1), then select Port Settings. Click on the Advanced button and in the window that opens, uncheck 'Use FIFO buffers' to disable the buffer function altogether.

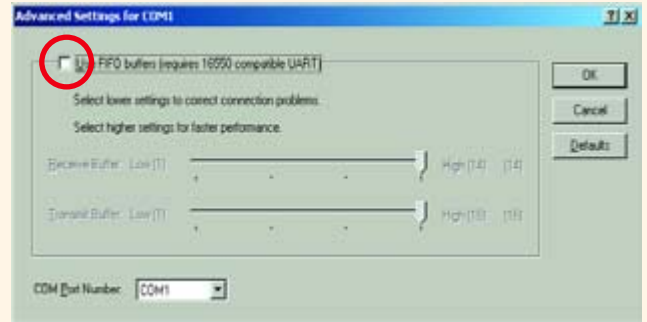

COMPONENTS LIST

Resistors:

R1, R4, R6, R7 = 22k Ω
 R2 = 10k Ω
 R3, R5 = 2k Ω
 R8 = 270 Ω

Capacitors:

C1 = 100nF
 C2 = 22 μ F 16V radial
 C3, C4 = 10 μ F 16V radial

Semiconductors:

D1 = 1N4148
 T1, T2 = BC557B
 T3 = BC547B
 IC1 = PIC12F675-C/P, programmed.
 Publishers order code **040267-41***
 IC2 = 7805CP

Miscellaneous:

K1 = 9-way sub-D socket (female),
 PCB edge mounting
 K2 = 5-way SIL pinheader
 Res1 = 8.000MHz ceramic resonator
 8-way IC socket
 RS232 serial cable (non-crossed)
 PCB, ref. 040267-1 from The
 PCBShop
 Disk, PIC source code files, order
 code **040267-11*** or Free
 Download

* see Elektor SHOP page or
www.elektor-electronics.co.uk

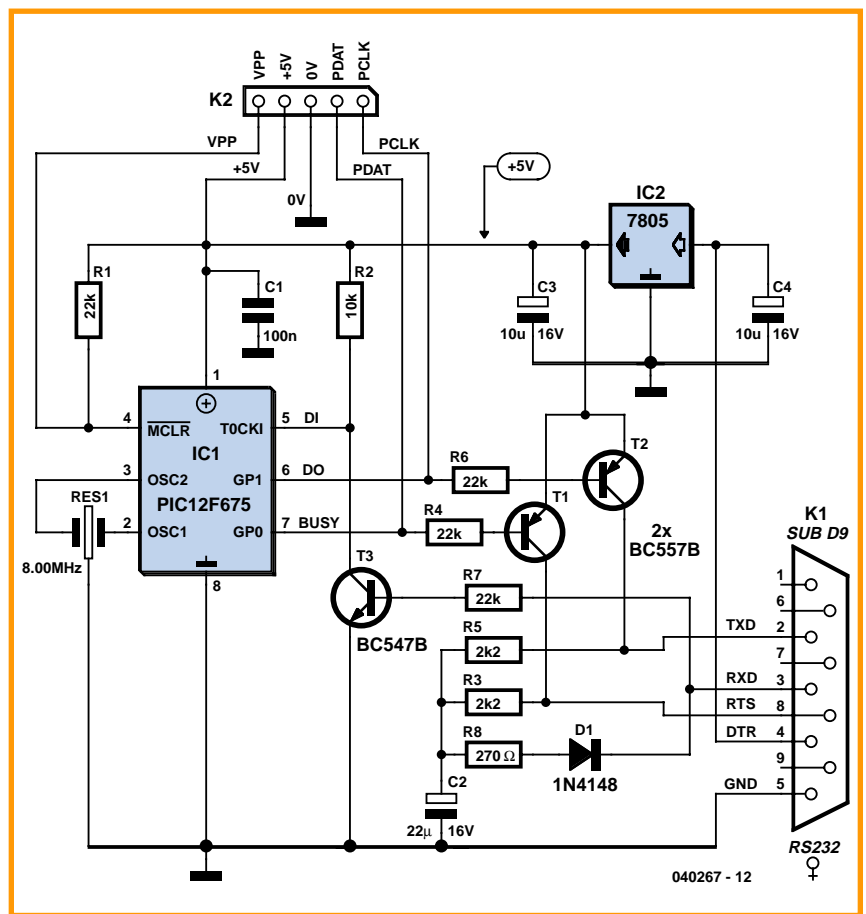

Figure 3. Circuit diagram of Colossus Jr.: a PIC with some I/O hardware strewn around it. Note that the circuit is powered off the PC's (inactive) DTR line, which is normally at about +10 V.

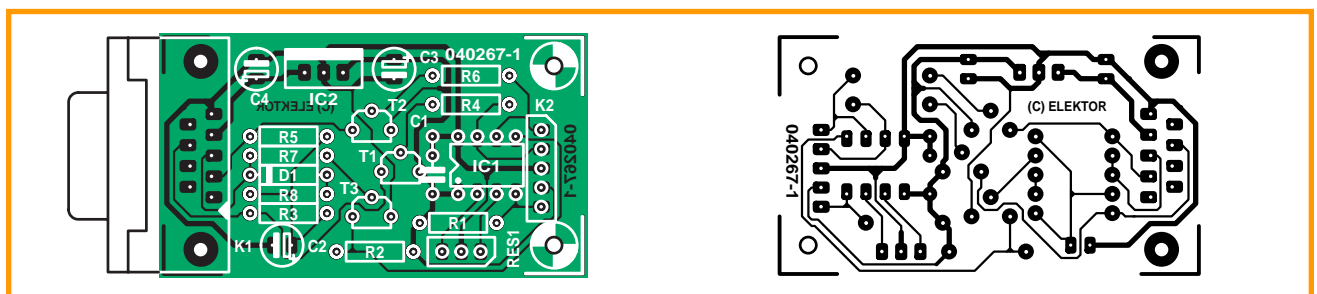

Figure 4. PCB copper track layout and component mounting plan.

current folder.

A PIC programmer supporting the 12F675 is required to transfer the object code file to the actual 8-pin chip. The circuit has a SIL pinheader, K2, containing all signals required for in-circuit (!) programming of the PIC.

More on the microcontroller software

The microcontroller code being available as a free download from our website (**040267-11.zip**), you have a great opportunity to learn a bit (pun intended) about cryptography and data authentication at PIC assembly code level — excellent reading for a rainy afternoon!

The code is divided into three parts, the operating core which receives data and authentication codes, the interrupt service routine which allows data to be received in the background while the microcontroller is working on previously received data, and the encryption engine which takes blocks of data and converts them into an encrypted version.

The serial input and output routines are what is known as 'bit-bangers' in that they don't need any supporting silicon on the microcontroller but use direct manipulation of general purpose input and output ports. The input routine is interrupt driven and is designed to receive data in the background, much if not all of the encryption can be done in the time that it takes to read a batch of eight characters. Output is also interrupt driven, but works in the foreground as little data has to be output; only the block acknowledgements and the "Verified" or "Rejected" messages.

(040267-1)

Reference and web pointers

[1] <http://csrc.nist.gov/publications/fips/fips46-3/fips46-3.pdf>

[2] <http://www.itl.nist.gov/fipspubs/fip113.htm>

[3] <http://www.aci.net/kalliste/des.htm>

[4] <http://www.microchip.com/download/appnote/appspec/16cxx/00555c.pdf>

[5] www.bletchleyparkheritage.org.uk/index.htm

Check & double-check: the DES routine

(code will not run on the Bletchley Park Colossus Rebuild...)

```

Processor PIC12F675
EXPAND
list      n=76, c=97, b=12, st=off, t=on, p=PIC12F675
Errorlevel 0,-302          ; Don't tell us about being in wrong page

; Configure      brown out detection enabled
;               no code protection
;               power on timer enabled
;               watchdog timer disabled
;               HS oscillator

        _CONFIG _BODEN_ON&_CP_OFF&_PWRTE_ON&_WDT_OFF&_HS_OSC

; Select the task to be assembled for by un-commenting the appropriate line below.

        #define Authorize
;       #define Validate

; All timings for the RS232 are based on an 8.00MHz resonator and a serial bit rate of
; 9600bps. Although only 7 bits of data are used, the byte size is 8 bits with an
; additional parity bit - the parity is even.

        #include "P12F675.inc"          ; Microchip supplied defs
        #include "des675.inc"

; This file does a convolution of the cryptographic key using the MPLAB assemblers itself
; to replace the "Permuted Choice 1" convolution.
;
; * * * * * EDIT THIS FILE TO CHANGE THE KEY * * * * *
;
; Note that the listing of this file has been switched off to reduce clutter.

        #include "PC1.INC"

org      0000

goto    init

org      0004

        #include "intser.asm"

; Table contains the key in the first 8 bytes, it additionally has status and
; judgement strings.

Table   addwf   PCL,F
        nop
        DT     PC1_0, PC1_1, PC1_2, PC1_3, PC1_4, PC1_5, PC1_6, PC1_7
Verify  DT     "Pass", 0
Reject  DT     "Fail", 0
Ready   DT     "Ready", 0

init    bsf    STATUS,RP0
        movlw b'11111100'          ; bit 0 is busy, 1 is tx data
        movwf TRISIO
        clrf  ANSEL
        bcf  STATUS,RP0

        movlw 7
        movwf CMCON          ; switch off comparators
    
```

PicoScope 3000 Series PC Oscilloscopes

The PicoScope 3000 series oscilloscopes are the latest offerings from the market leader in PC oscilloscopes combining high bandwidths with large buffer memories. Using the latest advances in electronics, the oscilloscopes connect to the USB port of any modern PC, making full use of the PCs' processing capabilities, large screens and familiar graphical user interfaces.

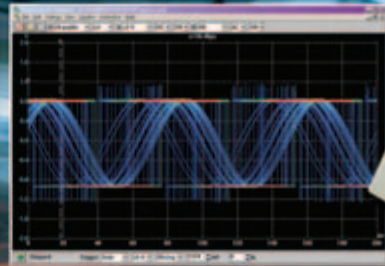

- High performance: 10GS/s sampling rate & 200MHz bandwidth
- 1MB buffer memory
- High speed USB 2.0 interface
- Advanced display & trigger modes
- Compact & portable
- Supplied with PicoScope & PicoLog software

PicoScope	3204	3205	3206
Bandwidth	50MHz	100MHz	200MHz
Sampling rate (repeat/trigger)	2.5GS/s	5GS/s	10GS/s
Sampling rate (single shot)	50MS/s	100MS/s	200MS/s
Channels	2 + Ext trigger	2 + Ext trigger/Sig gen	2 + Ext trigger/Sig gen
Oscilloscope timebases	5ns/div to 50ns/div	2ns/div to 50ns/div	1ns/div to 50ns/div
Timebase accuracy	50ppm	50ppm	50ppm
Spectrum ranges	0 to 25MHz	0 to 50MHz	0 to 100MHz
Buffer memory size	256KB	512KB	1MB
Resolution / accuracy	8 bits / 3%		
Ranges	±100mV to ±20V		
PC Connection	USB2.0 (USB1.1 compatible)		

Tel: 01480 396395

www.picotech.com/scope297

pico
Technology Limited

№1 Number One Systems

Easy-PC for Windows

The world beating PCB design software

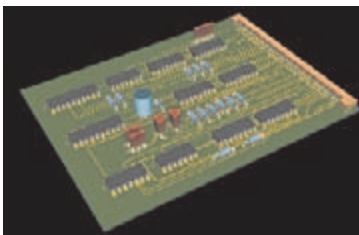

Easy-PC version 9 just gets better

Winning accolades the world over, Easy-PC for Windows V9 is another major milestone in the evolution of this extremely popular software tool. Try a demonstration copy of Easy-PC and prepare to be amazed at the power, versatility and remarkable value for money.

STILL FROM ONLY
£247
PLUS VAT

Version 9 features

- 3D Board View
- New Win XP User Interface
- Reverse Engineer SCM from PCB
- Track Fattening
- Interactive Schematic Routing
- New Sliding Toolbars
- Component Clearance Checks
- Alphanumeric Pin Names
- Plus many more exciting features.....

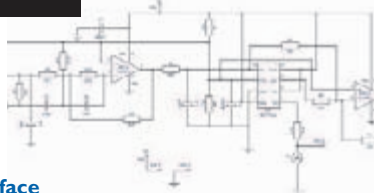

Fully integrated Schematics & PCB layout in a single application complete with forward and back annotation. Design and rules checks at all stages ensure integrity at all times. Professional manufacturing outputs allow you to finish the design process with ease.

Stop press... Stop press... Stop press... Stop press...

Easy-PC imports Eagle files as well as Tsien Boardmaker 2 files

call for a brochure, prices & CD on +44 (0)1684 773662
or e-mail sales@numberone.com
you can also download a demo from

www.numberone.com



Number One Systems - Oak Lane - Bredon - Tewkesbury - Glos - United Kingdom - GL20 7LR UK

27C512 Emulator

Florent Simonnot

More and more electronics hobbyists and professionals are using CPLDs to implement circuits. In this article, we work through the entire design process for a CPLD project from start to finish using a practical example. The result is a handy 27C512 EPROM emulator that is useful for debugging microcontroller systems.

This article shows you how to design an EPROM emulator with a minimum of 'glue chips'. Various types of CPLD and FPGA devices have already been used in several projects published in *Elektor Electronics*, so many readers already know how easy it is to use these components to develop digital circuitry.

Altera EPM7064

We selected the EPM7064S EPLD from the Altera CPLD family for this project because it allows a handful of chips to be eliminated from the design. The separate buffers, bidirectional ports, multiplexers and latches that would normally be required are no longer necessary if a CPLD is used. That makes the circuit board layout considerably smaller and simpler. If you've been following our recent series of articles about CPLDs, you can now put your knowledge to practical use with this project.

CPLD size

It's a good idea to draft a list of the desired CPLD properties before selecting a particular device. On the one hand, there's no point in purchasing an

expensive CPLD if only ten percent of its capacity will be used, while on the other hand, if the selected CPLD is too small you will be forced to use every trick you know to squeeze the design into the available space.

As every EPROM emulator must have a RAM capacity that is at least as large as that of the EPROM to be emulated, you already know several important parameters, particularly with regard to the required number of inputs and outputs (I/O pins). The calculation is straightforward: a 27C512 is organised as 64 KB \times 8 bits, so you will need to have 16 address lines and 8 data lines available to emulate it. As the RAM in the emulator must have at least the same capacity, it will also require at least the same number of I/O lines. That gives a total of 48 I/O lines ($16 \times 2 + 8 \times 2$). If you add around ten control lines for enabling the tri-state (high-impedance) mode and controlling other registers, you already end up with around 60 pins.

It's clear that a 44-pin or 64-pin package won't meet your requirements, particularly if you consider that CPLDs generally require supply connections on all sides of the package and sometimes even require several different supply voltages, because the voltage

An open design

required by the core logic (V_{ccint}) is usually different from the voltage required by the I/O logic (V_{ccio}). The net result in this case is that you're looking at a PLCC84 package.

It's more difficult to estimate how much circuit capacity you will need. A good technique is to count the number of flip-flops you will need for functions such as registers and counters. For instance, if you want to implement a (rather) large counter composed of 40 JK flip-flops, a device such as the EPM7032 is totally unsuitable because



n-ended



it has only 32 macrocells (as indicated by the type designation) that can be configured in the desired manner.

Counting registers

As can be seen from the block diagram in **Figure 1**, the microcontroller must perform its tasks using a link to the CPLD consisting of only 8 bits (from port A) and 3 control lines (from port C). Two sets of eight D-type flip-flops are needed to form a storage register for the 16 address bits of the RAM, and

Key features

- emulates a 27C512 EPROM
- file download via a serial port using three leads (Tx, Rx & GND) at a speed of 19,200 baud
- compatible with Intel hex format
- expansion connector for synchronisation with another emulator or system
- CPLD programmable in AHDL using the MAXPLUS II BASELINE freeware development environment (or QUARTUS)
- AVRGCC C compiler under GNU licence

implementing this logic requires 16 macrocells. It must be possible to put the data bus in a high-impedance state in order to isolate the emulator from the target system, and that costs 8 macrocells in the CPLD. Another 16 single-bit multiplexers are needed to drive the data bus of the RAM, which receives its data from the target system or the D register – that's another 16 cells.

A total of 40 macrocells (16 + 8 + 16) are thus necessary, not including the control lines, which also require space in the peripheral interconnect matrix of the CPLD. An EPM70674S should be able to meet these requirements.

TDF vs. GDF

You might expect to see these letters on the rear of a sports car, but in this case they stand for 'Text Design Files' and 'Graphic Design Files'. Although it would certainly be possible to describe the design using a sort of schematic diagram, here we use Altera's native hardware description language (AHDL) instead, for two principal reasons.

The first reason is that above a certain level of complexity it is essential to be able to use a language that describes the design, since otherwise it's nearly impossible to reliably distinguish a particular signal line among countless other signal lines in a schematic diagram displayed on a computer monitor with limited dimensions.

The second reason is that a hardware description language, regardless of whether it is VHDL, Verilog or AHDL, is both flexible and powerful. For instance, the width of a bus can be enlarged in a wink, while performing the same task at the graphic level quickly turns into slave labour. Although this approach may seem somewhat confusing at first, it is certainly worth the effort.

Now it's time to get down to work! You can grasp the bull by the horns by studying the AHDL listing for the EPM7064S (a portion of which is shown in the screen shot in **Figure 2**). The simplicity of this design has the additional advantage that there is no hierarchical structure – the 'top level' is always defined by the actual level. The first section of the description after 'subdesign' defines the ports and their directions. You can immediately recognise the RAM address and data busses and the emulator probe bus. For instance, D[7..0] describes the eight signals originating from the microcontroller. They are inputs to the Altera IC and have thus been quite logically assigned the description 'input'.

Things are a bit more complicated in the case of DE0[7-0], which form the actual data bus for the emulator probe. As it must be possible to put these lines in a high-impedance state while the RAM is being loaded, they must be connected using a bidirectional buffer. This sort of I/O would normally be handled using a bidirectional bus, but here open-drain outputs are used instead. To briefly return to the difference between graphic input (using a graphic design file, or GDF) and input in AHDL (using a text design file, or TDF), just imagine how much less time it takes to type these few lines of text than to select and position all sorts of graphic symbols using a mouse.

Now we come to the 'variable' section of the design description. That's where things such as the flip-flops, nodes and machine states necessary for the design must be declared. Only the address latches for the RAM address bus have to be declared for the emulator. They are 16 simple D-type flip-flops (DFFs), appropriately named 'address-latch'. The purpose of the next line

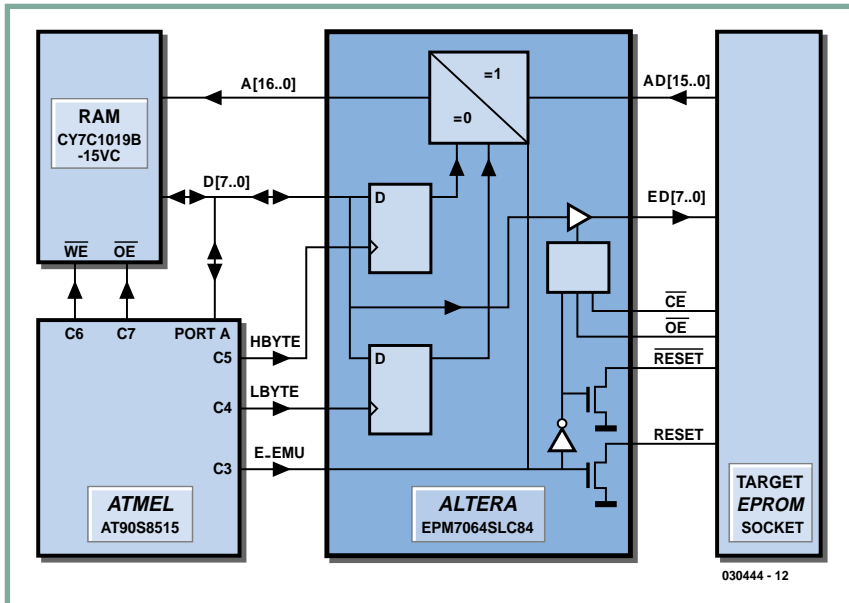

Figure 1. Block diagram of the versatile EPROM emulator.

may be somewhat unclear at first glance. That's where the tristate buffer connected to the bidirectional port (DE0[7-0]) is declared ('DE' stands for 'data emulation').

The third and final section contains the actual design description. If you're new to writing design descriptions using a hardware description language, you may not know that the order of the statements in the description is not important. The language is a 'parallel' language, which means that any given statement can be located before or after any other statement; the actual order doesn't matter. Here the description starts with assigning the inputs of the D-type flip-flops according to the block diagram, which means connecting bus D[7..0] to inputs [7..0] and [15..8]. The clock inputs of the first group are connected to the *lbyte* signal so the lower 8 bits of the address bus can be latched. The clock inputs of the second group of flip-flops are connected to *hbyte* so the upper eight bits can be latched on the rising edge.

The implementation of the multiplexer logic for the RAM address bus follows after the first four lines. The RAM address bus is connected to either the address latch or the emulator probe, depending on whether the emulator is operating in load mode or emulation mode

The bidirectional ports (DE[7-0]) are implemented using the 'tri' routine. It

has a data input ('in'), an enable input ('oe') for switching the output to a high-impedance state, and an output ('out') that must be connected to a bidirectional port. The 'in' input of this routine should not be confused with a physical input on an I/O pin of the CPLD.

A comment is in order here regarding the RESET and RESET signals. They are open-drain signals, so their ports are declared as bidirectional ('bidir') and a routine named 'opndrn' must be used. It is similar to the 'tri' routine, but it doesn't have an 'oe' input.

That completes the process of entering the definition file, but there's still more to do. First, you have to inform the MAXPLUS program that it must regard the file you just entered as the highest-order file (even if it's the only file available). You can do that via *File>Project>Set project to current file* or by typing Ctrl J. After this, you must specify which type of component to use for implementing the project. *Assign>Device* brings up a dialogue window in which you can specify your choice. In this case you must select 'EPM7064STC100-10'.

Now you're ready to make your first attempt at compiling the design, which you can do by clicking on the icon with the 'factory' symbol. If everything goes well (see the screen shot in Figure 3), only a couple of warnings will appear: A16 is stuck at ground and the component has less than 20% free pins.

But you're still not finished. Although the compilation ran without any errors, it also created a layout, or 'floorplan', on its own initiative. The current layout can be seen by examining the floorplan via *MAXPLUSII>Floorplan editor*. It's not exactly what you want, so you have to suggest a different arrangement to the compiler. That requires making a back-annotation to the project, which you can do by selecting *Assign>Back-annotate project* in the current floorplan. Among other things, that copies the compilation results (selected device, assignment of the ports to the pins, etc.) to an 'assignment & configuration file' (.acf file). Now you can select *Layout>Current assignment* in the floorplan editor to display the CPLD in a separate window (Figure 4), labelled with the names of the pins to which the ports have been assigned. The compiler made the assignments that it found most convenient. Now you have to convince it to do things more the way you want them. That involves using the mouse to rearrange the port assignments by dragging the ports to the proper pins until they match the electrical schematic forming the basis for the design. After this operation is finished, you have to recompile the design. The result of the new compilation can be used directly in the actual circuit.

It's interesting to note that with a complicated design, it's quite possible that the compiler will be unable to comply with the desired floorplan ('fit failed'). That means that no paths were found in the CPLD, or worse yet, the proposed internal routing would cause the timing to adversely affect the performance. However, that's not a problem with our design, which is truly very simple. The ability to select the pinout for a desired design makes it possible to considerably simplify the layout of the circuit board used in the final design. Some of the more powerful CAD programs route the FPGA and the PCB layers at the same time to prevent the fine track pattern from becoming too complex. If you don't have such a powerful (and expensive) program, you can work by switching back and forth between the various CAD programs.

Simulation

Before programming the CPLD, you can test the design using a simulation (even though the design is quite simple).

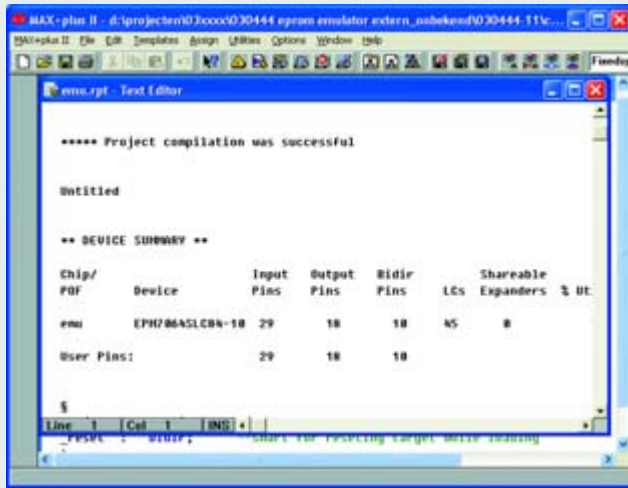

Figure 2. A portion of the emu.tdf file in the text editor prior to compilation.

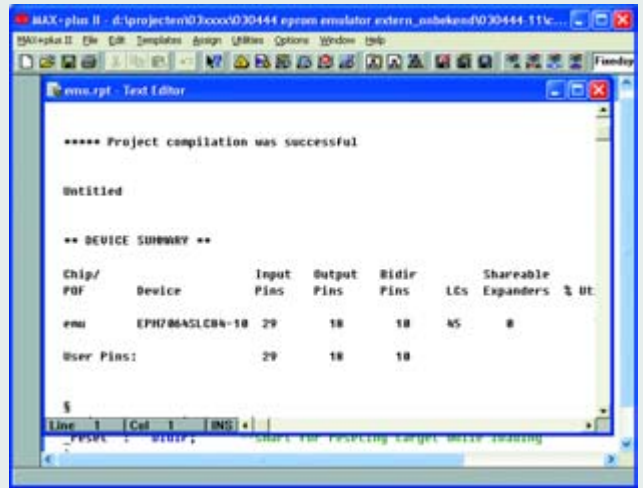

Figure 3. It's always nice to receive only one error message!

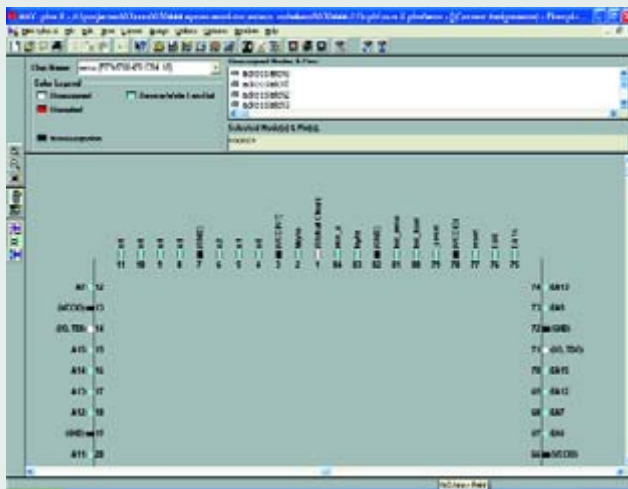

Figure 4. Example of the floorplan before the implementation.

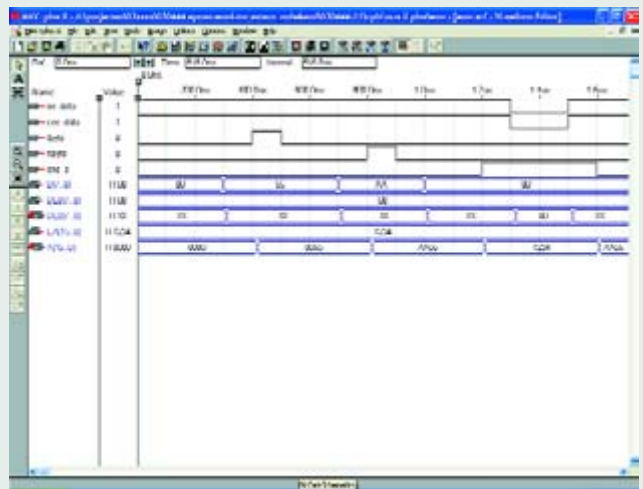

Figure 5. Tools like this show the power of modern development tools such as MAX+PLUS II.

Start with creating a simulation file by clicking on *File>New* and selecting *Waveform editor file*. An empty page will be displayed, and the first thing you should do is to save it with the same name as the project (which is 'emu' in this case). The recommended method involves entering vectors based on the simulator netlist (.snf) file, which includes timing information for the design. The screen dump shown in **Figure 5** should help clarify all of this.

Start by entering the RAM address and data ports (D[7..0] and A[16..0]) by right-clicking with the mouse and selecting *Insert nodes from SNF*. After that you can enter other signals, such as the signals from the emulator probe (DE[7-0]), the data bus (EA[15-0]), cee_data, oe_data, RESET and RESET.

Bear in mind that DE0[7-0] can be placed in the high-impedance state, for which reason there are two units for simulating the bus: *in* (i) and *out* (o). Finally, add the ports for the signals that control loading the registers (hbyte, lbyte and ene_a).

Here you can freely choose the values for the group of bus signals and the three possible values of the binary ports. If you're wondering how a binary port can have three different values, just remember that you can select 1, 0, or Z (high impedance) for many of the signals, such as the lines of the data bus on the board. A high impedance is represented in the .scf file by a dash, or by a 'z' in case of a bus.

After the values of the vectors have been entered, you can subject the design to a practical test by starting the simulator via *MAXPLUSII>Simula-*

tor. First check to see whether the values 0x55 and 0xAA appear successively on data bus D[7-0] and are latched by the rising edges of the lbyte and hbyte signals, respectively, to generate the value 0xAA55 on the RAM A[16-0] bus. Then check whether the emulator becomes active when the e_emu signal goes high after the reset signals of the emulator probe are set to the high-impedance (open drain) state or to 0.

In that state, all the values on the address bus of the target board are copied to the address bus of the RAM with a delay due to the propagation time of the EPLD. The data from the RAM is similarly copied to the data bus of the target board. An important aspect of the simulation is the propagation delay between the inputs and

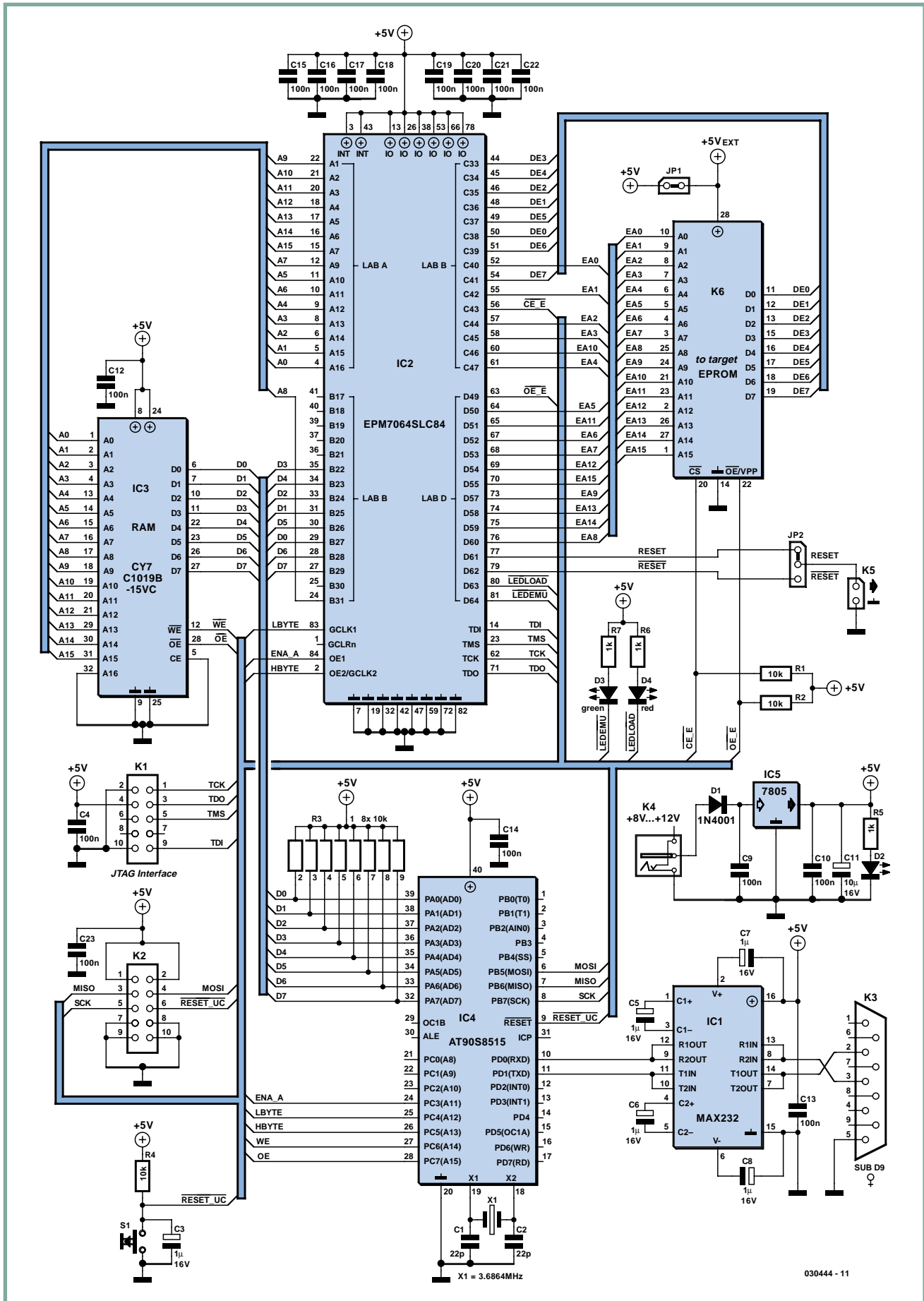

030444 - 11

Figure 6. Despite the high pin counts of the principal components, the schematic diagram of the EPROM emulator is easy to understand.

outputs of the CPLD, which it is determined based on theoretical data in the *.snf* file. The delay must be added to the access time of the RAM in order to obtain an idea of the timing performance of the emulator.

EPROMs are relatively slow, with access times ranging from 45 ns for fast types to 200 ns for slow types. The propagation delay is approximately 10 ns, which means you have a considerable margin given the 15-ns access time of the Cypress CY7C1019B-15VC RAM IC used in this design. You can thus expect a total access time T_{aa} of 35 ns (RAM access time plus two propagation delays through the CPLD for the round trip to and from the RAM). If that's not fast enough, you will have to use the -5 version of the same RAM type (5 ns access time). T_{aa} can be reduced even further by using the -5 version of the EPM7064. In that case you can expect T_{aa} to be approximately 15 ns.

This concludes the 'logical' portion of the project. However, we have a bit more to say here. You can easily use the QUARTUS II program from Altera instead of MAX Plus II. Altera recommends using the former program because no new release of the latter one will be issued. If you don't already have a licence for either one of these programs, you can download a 'web edition' or 'student version' from the Altera website after filling in a form. You will receive the necessary license.dat file by email.

Hardware

A glance at the schematic diagram in **Figure 6** shows that it contains few secrets and closely matches the block diagram in Figure 1. Power is supplied by a mains adapter, but it can also be tapped off from the target system via the supply pins of the EPROM being emulated. In the latter case, you should verify that the quality of the available 5-V supply is adequate and fit a jumper at JP1. The sole purpose of diode D1 is to protect against a reverse polarity connection, which is always a possibility when you're working on the bench. An interface IC in the form of a MAX232 (IC1) converts the RS232 signals to TTL levels. The microcontroller (IC4) is an Atmel AT90S8515 with flash memory. It can be programmed in system via ISP connector K2, which feeds

out the signal from the SP1 line and the reset signal. If you don't want to program the microcontroller yourself, you can obtain a pre-programmed version from Readers Services (order number **030444-41**).

The board can be reset using a push-button switch in case of a crash. The CPLD (IC2) is connected to K1, which makes its JTAG signals available to the external world so it can be programmed using a suitable device. A pre-programmed version of this IC is also available (Readers Services order number **030444-21**).

Note: in order to save space, the required resistors for the JTAG interface have been placed in the JTAG adapter cable. Also note the very large decoupling capacitors around the CPLD. They are necessary to ensure the quality of the supply voltage by absorbing current peaks that can cause EMI radiation. The RAM (IC3) has a capacity of 128 KB and a very short access time of only 15 ns, which is reason enough to use an SMD type. The RAM sees all the busses connected to the Altera IC, but the control lines for writing data and enabling the outputs are driven by the microcontroller.

The power supply requires little comment. An adapter with an output voltage in the range of 8–12 V can be used. It is connected to K4. The 7805 regulator provides the 5-V supply voltage required by the emulator. LED D2 indicates that the supply voltage is present.

Software

The program was written in C using the freeware GNU C compiler. That means that anyone who makes any changes to the program is obliged to disclose that fact and make the source code available.

The main task of the program is to provide a bridge between ASCII data received from a PC (via the RS232 line) and the core of the emulator. The program revolves around the following files:

- *main.c* This is the starting point of every C program, and here it is very short because it only initialises the UART for RS232 communications, enables interrupts, and determines the sequence of task execution. The endless loop for (;) contains:

A call to the function `TreatFrame Task()` to check whether a complete frame has been received.

Two subsequent if statements that verify the CRC and initiate conversion of the frame by the function `ParseFrame()`, which is also responsible for writing the received data to the RAM. Any frame with an incorrect CRC is rejected.

A set of three if statements that respectively handle requests to read out the content of the RAM, fill the RAM with '0x00', and fill the RAM with '0xFF' (very handy during the emulator development stage).

- *uart.c* Contains all the routines for receiving and transmitting characters, including the access points for the interrupt services. These service routines can be easily recognised by their names: 'SIGNAL' followed by the vector number (replaced by a more user-friendly label).

The `SIGNAL(SIG UART RECV)` routine is called each time a character is received via the RS232 line. It sets control flags in the order of reception ('switch case' is self-explanatory). If at least one frame has been sent, it is stored in a buffer in binary form.

There is a pair of routines that can be used to send a message from the flash memory (`PrintSerial`) or store a message in RAM (`UartSend`).

The `SetMode` function defines the control lines for the RAM and CPLD.

Finally, there are routines to fill the RAM (`ClearRam`), read out the RAM contents (`ReadBackRam`), and generate a hex dump.

- *utility.c* Contains utility routines and routines that are often used in projects for ASCII-to-binary and binary-to-ASCII conversion.

- *system.h* Contains all the #define statements belonging to the project and the hardware environment on the board. The frequency of the clock crystal is also specified here. The synonyms used to improve the readability of the code (such as 'checksumok' for '2') are also located here. In addition, there are a large number of #define statements that allow several C macros to be replaced by labels (such as `TRI_STATE_DATABUS`) to make it easy to set bits on the port that controls the RAM and the CPLD.

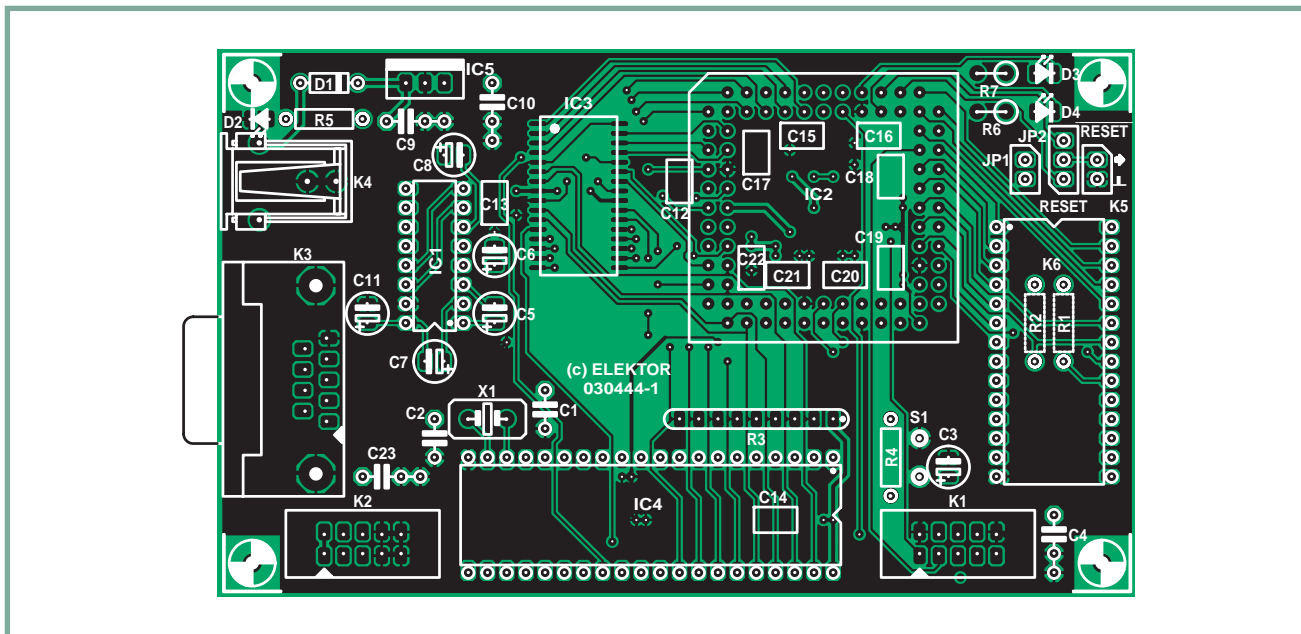

Figure 7. Component layout of the circuit board designed for the emulator.
Pdf file of copper track layouts (top and underside) available as free download (030444-1.zip).

COMPONENTS LIST

Resistors:

R1,R2,R4 = 10k Ω
 R3 = 10 k Ω 8-way SIL array
 R5,R6,R7 = 1k Ω

Capacitors:

C1,C2 = 22pF
 C3,C5-C8 = 1 μ F 16V radial
 C4,C9,C10,C23 = 100nF
 C12-C22 = 100nF, SMD, shape 1210
 C11 = 10 μ F 16V radial

Semiconductors:

D1 = 1N4001
 D2, D4 = LED 3mm red
 D3 = LED 3 mm green
 IC1 = MAX232N (Maxim)
 IC2 = EPM7064SLC84-15 PLCC,
 programmed, Publishers order code
030444-31
 IC3 = CY7C1019B-15VC (Cypress)
 IC4 = AT90S8515-4PC DIP 44 pins,
 programmed, Publishers order code
030444-41
 IC5 = 7805CP

Miscellaneous:

JP1 = 2-way SIL pinheader with jumper

JP2 = 3-way SIL pinheader with jumper
 K1,K2 = 10-way boxheader
 K3 = 9-way sub-D socket (female), PCB
 mount
 K4 = DC adaptor socket
 K5 = 2-way SIL pinheader
 K6 = length of 28-way flatcable with DIP
 IDC connector
 S1 = pushbutton, 1 make contact
 X1 = 3.6864MHz quartz crystal
 84-way PLCC socket
 PCB, ref. **030444-1** from the PCBShop
 Enclosure, e.g., Hammond type 591-D
 Disk, project software, Publishers order
 code **030444-11** or Free Download.

The makefile file is probably a bit strange for beginners. It contains information for the linker to tell it which files must be linked to other files.

It also includes information about the mutual relationships of the various files, so the amount of recompilation can be kept to a minimum if only small changes are made.

The author used Microsoft Visual C++ as an editor to simplify writing the source code, which explains the presence of the .dsw file. A simple word processor could also be used for that task.

Construction

Construction of the emulator is practically child's play thanks to the double-sided, plated-through PCB, whose board layouts is shown in **Figure 7**. However, there are a few points that require special attention.

The SMD components used in the circuit must be fitted first. In particular, a fine-tipped soldering iron is required for the SMD capacitors on the solder side of the board (C12–C14) and the decoupling capacitors for the CPLD (C15–C22), and extra flux may be necessary. These components can be fitted quite easily. All it takes is a tiny bit of solder at each end.

Resistors R1 and R2 are fitted under the DIP connector.

Soldering the RAM (IC3) requires a certain amount of care. Start by placing it precisely on top of the solder lands. Then solder two pins at the extreme corners. If the IC is properly positioned, you can continue with soldering the other pins, making sure to allow the IC enough time to cool down. It's good practice to inspect the solder joints with a loupe after you're finished. If there are any shorts between the pins, the excess solder can be removed using finely stranded wire with liquid flux.



Figure 8. Fully assembled emulator prototype. It differs slightly from the final PCB supplied by us. Note the especially small dimensions of some of the capacitors (including the 1- μ F types).

Use the same procedure for the PLCC socket with its 84 pins. Pin 1 of the socket can be recognised by the bevelled corner. Checking your soldering with a loupe is a good idea in this case as well, in light of the pin spacing of 0.1 inch.

Fit the small components next, such as the crystal and the capacitors, diodes, LEDs and resistors.

Pay attention to the polarity of the electrolytic capacitors, LEDs, diodes and the like. The orientation of resistor network R3 is also important.

Finally, fit the various headers and PCB-mount connectors. The shell of the Sub-D connector is secured using two tabs that fit into openings in the PCB. The microcontroller should preferably be fitted in a good-quality IC socket.

After you finish the final inspection of your work, but before you fit the two most important ICs, it's probably a good idea to connect the supply voltage and check whether it is present at a number of critical locations: pins 8 and 24 of IC3, pin 40 of IC4, and pins 3, 13, 26, etc. of the socket for IC2 (refer to the schematic). Switch off the supply voltage after this test has been successfully completed. Now it's time to fit the EPM7064 in its socket. Note that pin 1 is located to the left of the bevelled edge of the component.

Now you can connect the supply voltage again.

D2 (close to the voltage regulator) should light up to indicate that the supply voltage is present.

Operation

The emulator communicates with the PC using Hyperterminal or a similar program. To initiate a dialogue, configure the program for a baud rate of 19,200, no handshake (neither hardware nor software), and ASCII-only dialogue.

If the RS232 link is properly configured, the terminal window will display a welcome message after the supply voltage is switched on, along with a list of available instructions. To check whether everything is OK, you can make a simple test by pressing the 'r' key to read out the RAM. The content of the RAM will be arbitrary. Next, use the 'c' command to set the content of the RAM to '0x00', and check this by reading out the RAM again. The 's' key loads '0xFF' into the memory.

Type an 'I' on the PC to download a hex file and transfer it in text format. After the file has been loaded, you can type 'e' to read out the memory again and switch to emulation mode.

You can reinitiate the process whenever you wish (such as after a crash or

if the firmware detects an error in the transmitted data) by typing 'R'.

There is no timeout for entering commands or downloading hex files. That means you can also enter Intel hex code manually without any problems. Each CRC error or other error is indicated by an error message. You can easily transfer several files in succession to the emulator. They will be placed at the specified addresses without erasing or corrupting the data already present.

It is also possible to make changes manually. That can be handy when you want to modify a few values without recompiling and downloading the entire program.

MAX+PLUS II vs. QUARTUS

As already mentioned, Altera provides two different integrated development environments (IDEs) for its products: MAX+PLUS II and QUARTUS II. The author used the first of these IDEs, while the *Elektor Electronics* lab used the second one. You can download both versions and make your own choice, and they are also available from Readers Services on diskette (order number **030444-11**). The project file also includes a folder named ' μ C' that contains the source and hex code for the microcontroller.

Altera also provides an explanation of

Prototypes

Putting a project like this on the rails doesn't always go as smoothly as originally expected – not even if the author has provided an outstanding design on paper and has already built several different examples of the circuit, all of which work just fine. We tried various approaches to converting this emulator into a 'general purpose' design. We ultimately settled on using a modern RAM IC, in part for timing reasons. It comes in a 32-pin TSOP32 package with straight pins. As can be seen from the photo, the initial prototypes had a few creative features. After all operational problems in the emulator design were eliminated, the Elektor Electronics lab designed the final version that is described in this article.

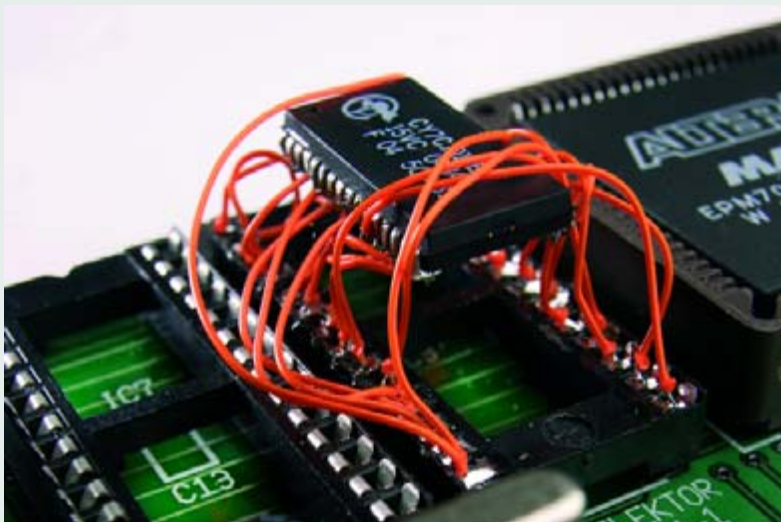

how to make the transition from MAX+PLUS II to QUARTUS II (see the Internet addresses at the end of the article). To make migration to QUARTUS II painless for experienced MAX+PLUS II users, QUARTUS II has a 'look & feel' option that gives users the feeling of working with MAX+PLUS II while actually using QUARTUS II.

Final remarks

This is clearly a project that can be modified according to your particular ideas and wishes.

It is an 'open' project in the sense that all of the source code is freely available from the moment that it is published, in accordance with the conditions of the GNU licence.

(030444-1)

References

'EPROM Emulator', *Elektor Electronics*, November 2002

Internet

Version 10.2 of MAX+PLUS II:

www.altera.com/products/software/products/legacy/max/sof-emax_baseline.html

Version 4.2 of QUARTUS II (several dozen MBI!):

www.altera.com/support/software/download/altera_design/quartus_we/dnl-quartus_we.jsp

Migrating from MAX+PLUS II to QUARTUS II:

www.altera.com/products/software/switching/maxplus2/qts-mp2_user.html

All about the MAX 7000 family:

www.altera.com/products/devices/max7k/m7k-index.html

MAX 7000 datasheet: www.altera.com/literature/ds/m7000.pdf

CYC1019B datasheet:

www.cypress-japan.co.jp/products/datasheet.php?partnum=CY7C1019B&familyid=36

GNU compiler, a large number of links to private Internet sites for SPI programmers, and a fantastic forum: www.avrfreaks.org

About the author

Regular readers of *Elektor Electronics* will probably recognise Florent Simonnot as the designer of the Mini Test Pattern Generator published in the June 2003 issue. After obtaining a DESS degree in microelectronics in Bordeaux, Florent worked for two years in a company that develops cameras for industrial and surveillance applications, followed by three years in a company that built flight simulators. As a result of the crisis in the air transport industry, he was forced to move to an international group that is active in the automotive electronics area, where he presently holds the position of project manager for electronics.

In keeping with his first formal degree, a technician's diploma to which he likes to add the qualification 'developer & hobbyist', Florent always keeps his soldering iron within handy reach.



Lichfield Electronics

Online Shop: www.LichfieldElectronics.co.uk



Line Tracking Mouse
Using three IR Photo interrupters this mouse will follow a black line using sight alone. £24.99



Infrared Remote Control Kit
A kit that plays music on command sent by infrared. Could be used to control other devices. £14.99



Metal Detector Kit
Find out how a metal detector works with this simple to assemble kit. £9.99



10 LED flasher
Using 2 transistors, 2 capacitors and 6 Resistors this kit generates an eye catching display. £4.99

Lots More Kits Available.

Components

Resistors: CR25 & 0805 (All values) CR12, MR25 (Popular values)
Capacitors: Electrolic, Polyester, Mylar & Ceramic. (Radial)
And More: DC Regulators, 74 & 4K logic, transistors, sockets, Nixie tubes, etc.



A small selection of the tools we sell.
Aoyue 909 with temperature controlled iron, Hot air gun and 0-15V 1.5A PSU. £99.99



Aoyue 936 temperature controlled 35W soldering iron comes with stand. (200C - 480C) £24.99



Aoyue 398 0-15V 1.5A PSU & Work station. £28



Open: 9 am - 5 pm Mon-Sat Tel: (01543) 256684
The Corn Exchange, Conduit St, Lichfield, Staffs. WS13 6JU

A QUANTUM LEAP IN
EMBEDDED CONTROLLERS

Quick FIRE SUPERCONTROLLERS

Our range provides:-

- The fastest 68000 based Core up to 66 Mhz.
- Extensive I/O:- Serial, IrDA, SPI, I²C, Analogue, Timers/Counters, RTC, etc.
- Large Memory Capacity:- Flash, SRAM, DRAM.
- Supports:- Mono & Colour LCD's, Touch Panels & Keypads, Very Low Power.

ALSO LOW COST

DEVELOPMENT

- Target easily & quickly.
- Full ANSI 'C' compiler, assembler & linker all Windows32 based.
- Source Level Debug.
- Full Driver Support with Libraries.
- Real Time Multitasking OS with a free run time licence.
- FREE Unlimited email support.

www.cms.uk.com

see our web site for full details

CAMBRIDGE MICROPROCESSOR SYSTEMS LTD



Unit 17-18 Zone 'D' Chelmsford Rd. Ind. Est.
Great Dunmow, Essex CM6 1XG

Telephone: **01371 875644**
email: sales@cms.uk.com

PCB-POOL®

SERVICING YOUR COMPLETE PROTOTYPE NEEDS

- Prototypes at a fraction of the cost
- Industry standard quality
- Tooling and setup included
- Follow up series runs
- Any contour
- CAM / CAD consulting
- Fr4 1.6mm, 35µm Cu

PRICE EXAMPLE:
1 EUROCARD DS/PTH
+ Tooling
+ Photoplots
+ VAT

= £ 29.89*

*Sterling rates may vary. Price = € 49

€ 49



Tel: +353 (0)61 701170
Fax: +353 (0)61 701144
E-Mail: sales@beta-layout.com

Freephone
0800-389 8560

Simply send your files and order ONLINE!

WWW.PCB-POOL.COM

TARGET Pretel OT GraphiCode PRITTEL Electronics

DELPHI FOR ELECTRONIC ENGINEERS

Part 8: the Delphi Stamp

Detlef Overbeek,
Anton Vogelaar and Siegfried Zuhr

With the summer holidays behind us, it's time for most people to get back to work so this Delphi course goes back into full swing as well. This month we take a look at the Delphi Stamp, a universal hardware controller with an onboard BIOS. This controller can function on a stand-alone basis or it can be controlled via a PC. It has several standard hardware interfaces and it is of course possible to add your own interface to the module.

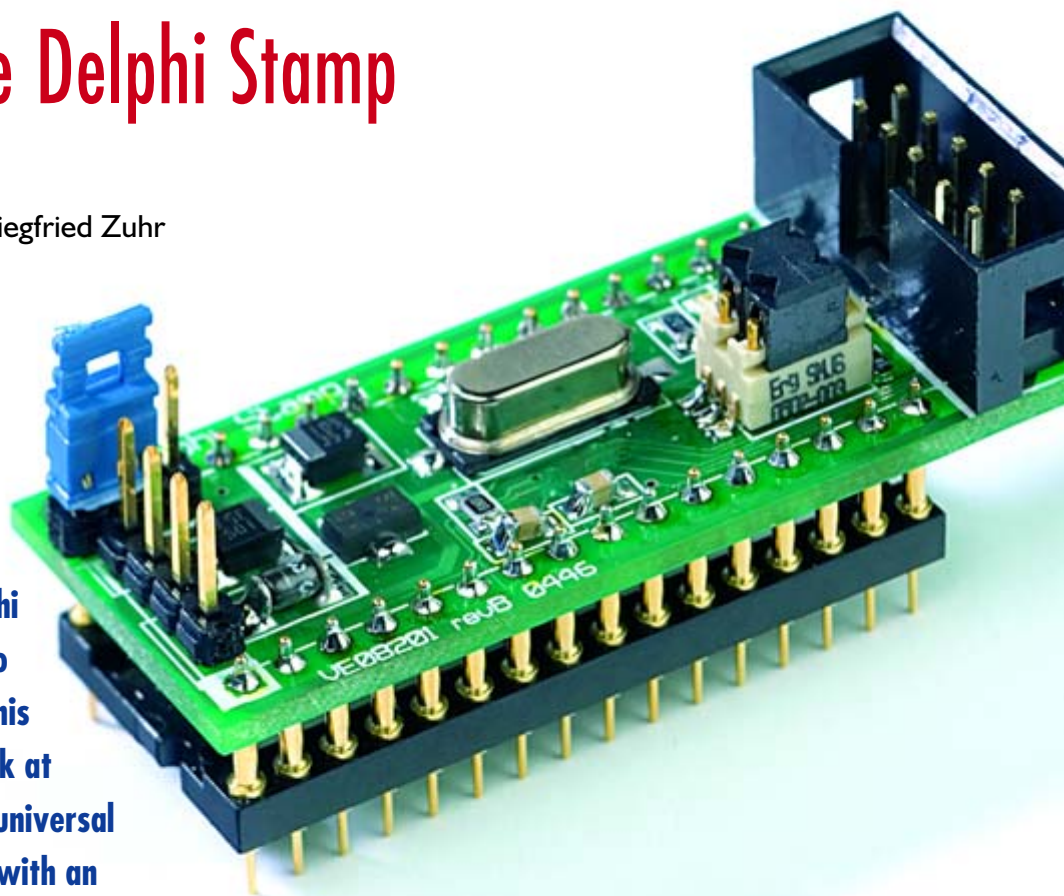

The Delphi Stamp is a fast and universal miniature plug-in controller with a large amount of memory and many input and output capabilities. The firmware is developed in Delphi. The onboard BIOS is used to run this on a stand-alone basis in the Delphi Stamp. It is also possible for an application on a PC, written in Delphi, to control another application that runs on the Delphi Stamp. The ATmega128 used here is a RISC processor with a clock frequency of 14.7456 MHz. Most of its instructions are executed in a single clock cycle (about 68 ns). The program code is stored in Flash memory. Since the instructions, with the exception of JMP, LDS and STS, occupy two bytes, it is possible to store up to around 60,000 assembler instructions in the Flash memory. The final 8 kB is protected and contains the BIOS. The BIOS consists of four modules: the loader, the M485 server, the resident drivers and the interface server (see **Figure 1**). The loader is used to receive the object code via the RS232 link and store it into the Flash memory. The

communications between the Delphi Stamp and PC use the M485 protocol. The loader is part of the M485 server. This server can be used to inspect the RAM, Flash, EEPROM, registers and I/O registers, which is very useful during the debugging of programs. The server is also used to communicate with an external GUI (Graphical User Interface).

The resident drivers take care of the onboard LEDs and jumpers, a 16-character display, a bipolar stepper motor, a push button, seven LEDs in a dice configuration and a potentiometer. The interface server also makes use of the resident drivers. This interface server makes sure that the state of the connected hardware corresponds to the state specified in a data record in RAM. This process happens 20 times per second. There is a DLL available that can be used by a Delphi application to communicate with this record (M485.dll). In this way the Delphi Stamp can be used as an interface.

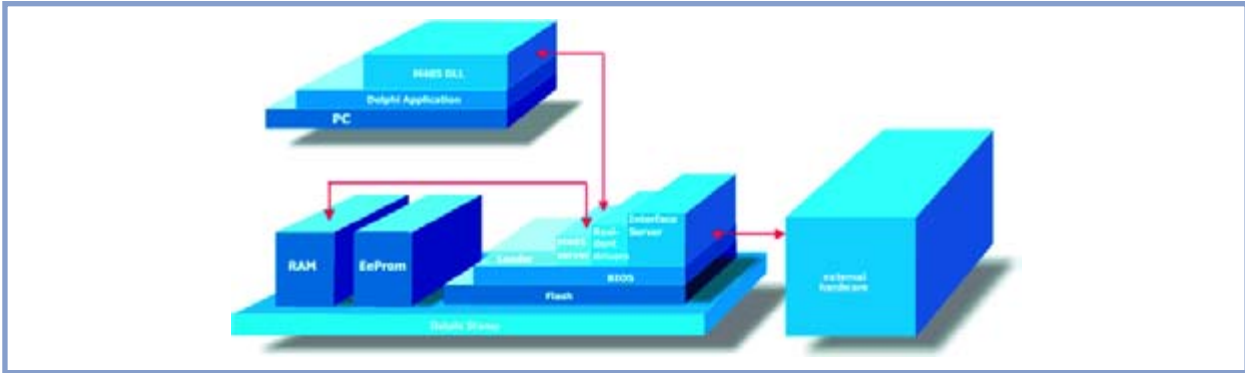

Figure 1. Structure of the different functional units inside the Delphi Stamp.

Hardware configurations

To make it easier to start using the Delphi Stamp we have designed standard hardware configurations for

each of the I/O capabilities (see **Figure 2**). As long as compatible external hardware is connected, you can make use of the interface server, the standard drivers and an I/O test program.

Specifications

- **ATMega128:** 128 kB Flash – 4 kB RAM – 4 kB EEPROM – 4 timers – 10 bit AD-converter with 15 ksamples/sec – Analogue comparator – Sleep mode – 2 UARTS for RS232 and RS485 – I²C – 25 digital inputs/outputs – JTAG and ISP interface
- **Supply voltage 6-9 VDC (onboard regulator; not suitable for powering external loads)**
- **Current consumption in sleep mode: 10 mA**
- **Digital I/O specs: 30 mA source @ 1 V drop, 40 mA sink @ 1 V drop**
- **The data sheet is at www.atmel.com/dyn/resources/prod_documents/doc2467.pdf**
- **A document that gives detailed descriptions of all instructions can be found at: www.atmel.com/dyn/resources/prod_documents/doc0856.pdf**

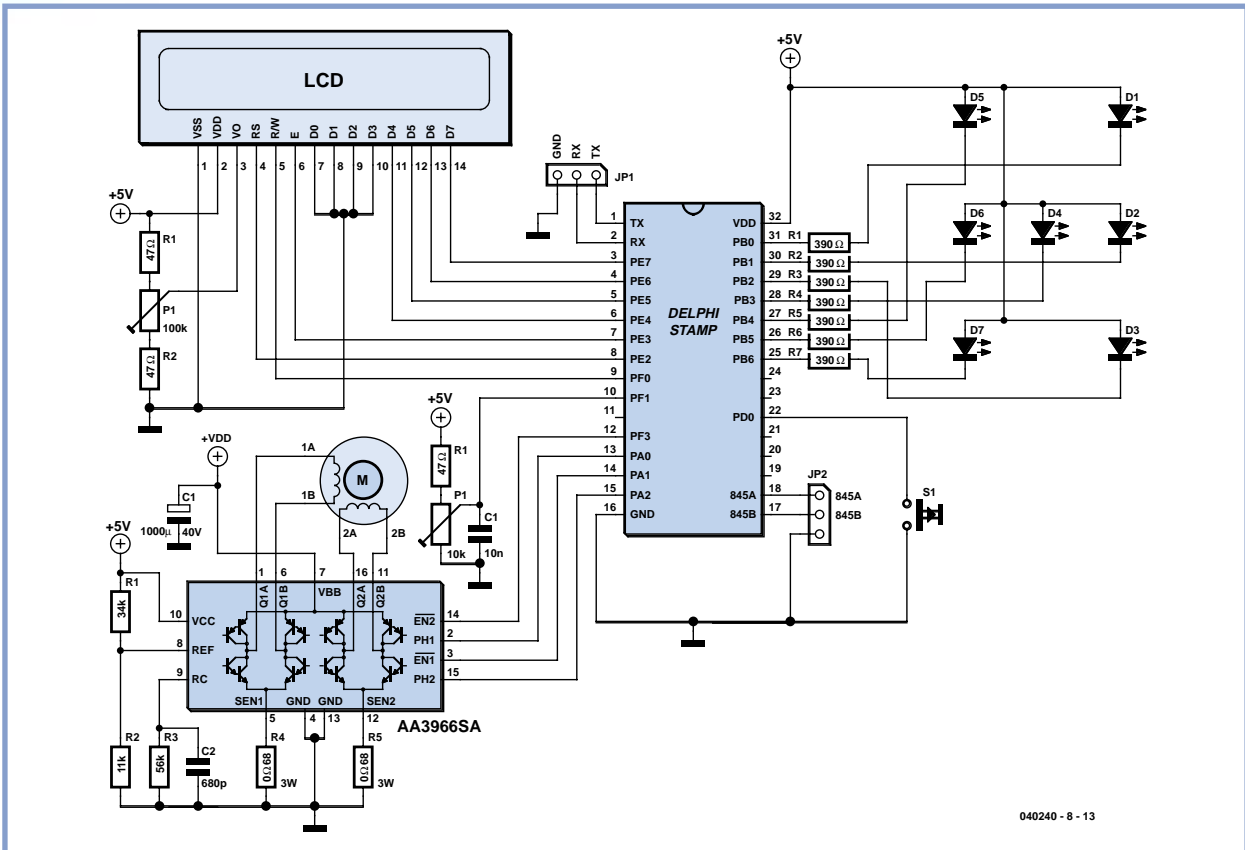

Figure 2. The different I/O capabilities of the Delphi Stamp. With the help of the standard drivers it is easy to interface to this hardware.



Figure 3. PDemo.prj is the container with all files that are in the Delphi simulation project.

For example, you can connect a bipolar stepper motor having 1.8° steps and use it in half-step mode (giving 400 steps per revolution). You can also read the position of a potentiometer (voltage between 0 and 2.56 V) and 7 LEDs can be driven. The RS485 connection can be used to implement a network with a maximum cable length of 1000 metres, which can have a maximum of 128 devices connected to it. An LC display (LCD) can be attached with a 16-character display.

Delphi Stamp as a controller

When the Delphi Stamp is used as a controller there is normally no link to the PC. To be certain that the controller works reliably it is a good idea to develop and simulate the controller software on a PC first. A Delphi form with visual components emulates the external hardware. All driver routines are written in separate units. When the simulation works satisfactorily the driver units are converted by the cross-compiler *PasAvr* into a binary hex file, which contains the object code for the Delphi Stamp. The program *Mon485*, included with the Delphi Stamp kit, writes this hex file into the Flash memory of the Delphi Stamp, after which the program is started. The controller now functions independently and the link to the PC is no longer required.

Simulation

PDemo.prj is the container for all files in the Delphi simulation project (see **Figure 3**). *DMain.pas* is a data module and can only include non-visual components such as the *TTimer*. This module simulates the power-on vector and other interrupts through the use of Delphi events. *FGUI.pas* is of type *TForm*, which can contain visual components. These visual components replace the external hardware of the controller, such as switches, LEDs, LCD, motor, etc. *UDrivers.pas* contains the drivers to control *FGUI.pas*. *UControl.pas* contains the driver routines and is compatible with the *PasAvr* cross compiler.

Cross-compilation and uploading

Demo.prj is the container file for the remaining files in the demo controller project for the Delphi Stamp (see **Figure 4**). *UMain.pas* contains the power-on code and all interrupt vectors. This unit is identical in virtually all Delphi Stamp applications and is included as a template with the kit. *Drivers.pas* is functionally the same as *UDrivers.pas*, which we used in the simulation program. However, the implementation is different since it now has to drive real hardware. For the standard hardware you can use the resident drivers from the BIOS. *UControl.pas* holds the functionality for the controller and is copied from *UControl.pas* from the simulator. *PasAvr* is the cross compiler included with the kit. *PasAvr.exe* converts the project *Demo.prj* to the file *Demo.hex*. The program has no restrictions in how long it can be used for or in the size of the generated hex file. *PasAvr* has its own IDE and simulator for writing programs in Pascal and Assembler outside of Delphi. *Demo.hex* contains the generated object code for the ATmega128 controller in Intel-hex format. The monitor program *Mon485* is used to communicate with the loader on the Delphi Stamp. This takes care of programming the received object code into the Flash memory. The Delphi Stamp program can be started using *Mon485* or by resetting the Delphi Stamp.

Delphi Stamp as interface

We start by describing the different parts of this project. To control a stepper motor we need a form on the PC that

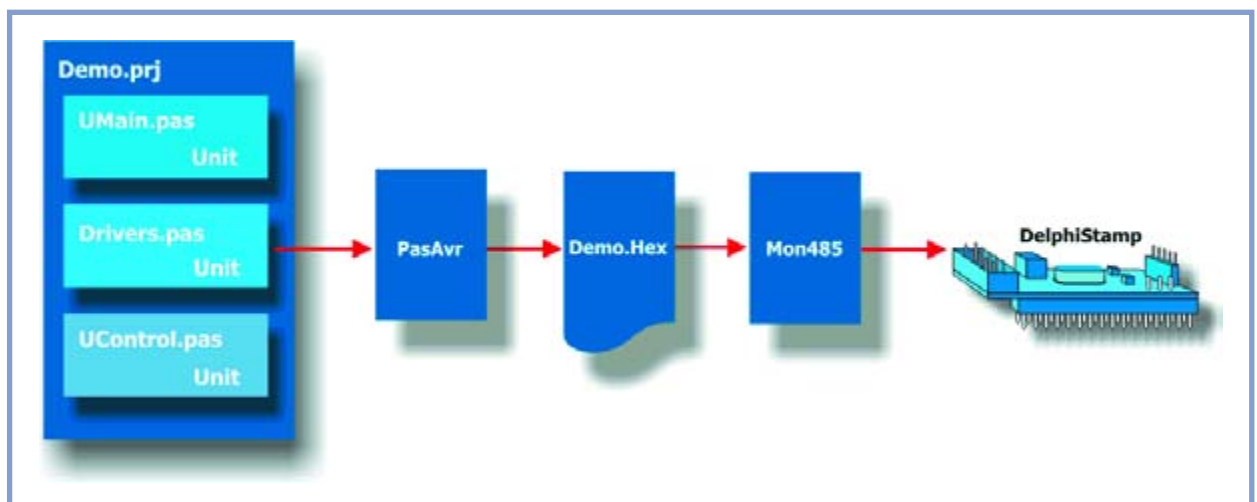

Figure 4. Demo.prj is the container file for the rest of the files in the demo controller project.

functions as a console. The motor is connected to the Delphi Stamp via a driver. There is a slider control on the form that is used to set the angle of the motor from 0 to 360 degrees, as well as three buttons that are used to quickly set the position to 0, 180 or 360 degrees. There is also an LCD connected to the Delphi Stamp, which displays the angle.

The control programs runs on the PC and is written in Delphi. An interface server runs on the Delphi Stamp that synchronises the connected hardware with the parameters sent to the Delphi Stamp by the PC.

To reduce the possibility of errors in complex programs it is recommended that they are split up into smaller, logical blocks. Delphi has several different types of module, which are the unit, library, form, and data module. The Delphi project *Plnf1.dpr* is divided into five parts (see **Figure 5**).

- The data module *DMain.pas* is, apart from a unit in its own right, also a container for non-visual components, such as timers. This data module provides a power-on event and a timer, which transmits updated information to the Delphi Stamp every 200 ms.
- The form *UGUI.pas* is a unit that can contain visual components. This form has a slider *TTrackBar* and three *TButtons*. The buttons are combined with the slider to quickly go to an angle of 0, 180 or 360 degrees.
- The unit *UControl.pas* holds the functionality of the application. The procedure *ControlInit* initialises all hardware at power-on. The procedure *ControlExe* refreshes the interface server on the Delphi Stamp every 200 ms. For communications with the Delphi Stamp and the GUI we use the drivers in unit *UDrivers.pas*.
- The unit *UDrivers.pas* holds the basic driver routines for the GUI and the Delphi Stamp. Since this unit is rarely modified it lends itself to reuse in many applications. The CDROM included with the kit contains a standard unit for communicating with all standard hardware.

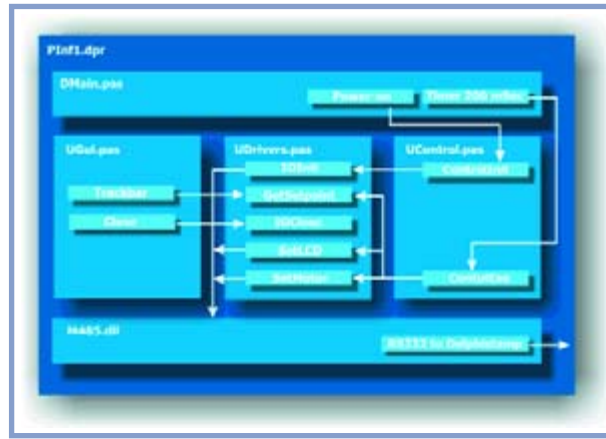

Figure 5. The Delphi project *Plnf1.dpr* consists of five parts.

- *M485.DLL* is a library unit that can also be used by other applications. This library is supplied with the kit and contains the software for the communications with the Delphi Stamp. It uses an RS232 port on the PC.

Implementation in Delphi

As usual, we start a new project from the Delphi IDE via:

File->New->Application

and we save it on the hard drive by:

File->Save->all <Directory\DS Inf1 > *UGUI.pas* and *Plnf1.dpr*

Place the following on the form:

Standard | label

Win32 | Trackbar

Standard | Button (three times)

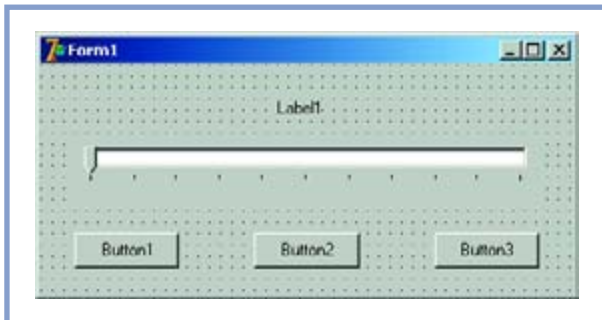

Figure 6. We add a Label, a Trackbar and three Buttons to the form

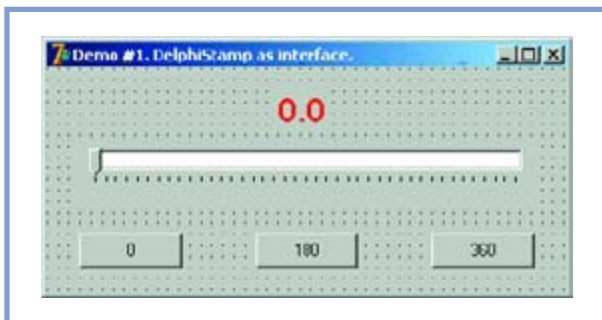

Figure 7. Using the Object Inspector we change the properties according to Table 1.

Table 1. Properties of the form for the interface with the potentiometer.			
Object	Property	Value	Notes
Form1	Name	FGUI	Use descriptive names
	Caption	Demo #1	
Label1	Name	LbPos	
	Caption	0.0	
	Font.Size	18	Text height is 18 pixels
	Font.Style.fsBold	True	Bold text
Trackbar1	Font.Color	clRed	Red font colour
	Name	TbrPos	
	Max	400	1 revolution has 400 steps
Button1	Frequency	10	Scale divisions are every 10 steps
	Name	Btn0	
Button2	Caption	0	
	Name	Btn180	
Button3	Caption	180	
	Tag	200	180 degrees are 200 steps
	Name	Btn360	
Button3	Caption	360	
	Tag	400	360 degrees are 400 steps

The form now looks like the one in **Figure 6**. Using the object inspector we change the properties as shown in **Table 1**. The form should now look like the one in **Figure 7**.

The OnClick event of Btn0 has to be implemented next. The OnClick events of Btn180 and Btn360 are the same as that of Btn0. In the Object Inspector of Btn180 and Btn360 we can choose Btn0Click from the dropdown list of the OnClick event. In the OnClick event the slider is set to the value of Tag, which is either 0, 200 or 400.

```
Procedure TFGUI.Btn0Click (Sender : TObject);
(* User setting to 0, 180 or 360 degrees *)
Begin
  TbrPos.Position := (Sender As
TComponent).Tag;
  RefreshLabel
End;
```

The *Format* function is used to show the angle of the stepper motor on the label component. The format-string '%.1f' specifies that the result has a fixed single decimal place. The value to be show is between the right-angled brackets [...]. The calculation " $* 360/400$ " converts the motor steps into degrees.

```
Procedure TFGUI.RefreshLabel;
(* Update position label conform trackbar
position *)
Begin
  LbPos.Caption := Format ('%.1f',
[TbrPos.Position * 360 / 400])
End;
```

The Data Module UMain implements the power-on event as soon as DMain is created. The *OnTimer* event should call the procedure *ControlExe* once every 200 ms. This is done by setting the Interval property of Timer1 to 200. The unit UDrivers takes care of the basic communications between the user interface and the hardware. The function *GetSetpoint* returns the position of the slider in UGUI in units of motor steps.

```
Function GetSetpoint : Integer;
(* Provide slider position from UGUI *)
Begin
  Result := FGUI.TbrPos.Position;
End;
```

The procedure *IoInit* creates a connection with the Delphi Stamp. There can be circumstances where this can fail, for example if there is no Com port or if it is already used by another process. The *Try ... Except* construction traps this exception, shows an error message and halts the program.

```
Procedure IoInit;
(* Energize stepper motor and clear LCD *)
Begin
  Try DS485_Open (ComPort); // Open a con-
nection with the Delphi Stamp
  Except
    ShowMessage ('Error. Unable to connect
to Delphi Stamp');
    Application.Terminate
  End;
  InfDta.MotorSts := $81; // Energize
motor
```

```
DS485_Wr (1, Word (@PInfDta.MotorSts),
InfDta.MotorSts)
End;
```

The 16-character LCD consists of two 8-character lines, which are mounted next to each other. These two 8-character lines are sent separately to the interface server. The lines are only sent when their contents have changed. This is checked for by the statement *SLcd <> LcdStr1(2)* in the code below.

```
Begin
  SLcd := LeftStr (S, 8); // Left half of
S
  If SLcd <> LcdStr1 Then // If left sec-
tion changed
  Begin
    LcdStr1 := SLcd;
    LcdStr1 [0] := Char (Byte (LcdStr1 [0])
Or $80); // Set write request
    DS485_Wr (9, Word (@PInfDta.LcdStr1),
InfDta.LcdStr1 [0]);
    LcdS1 := SLcd;
  End;
  SLcd := RightStr (S, 8); // Right half of
S
  If SLcd <> LcdStr2 Then // If right sec-
tion changed
  Begin
    LcdStr2 := SLcd;
    LcdStr2 [0] := Char (Byte (LcdStr2 [0])
Or $80); // Set write request
    DS485_Wr (9, Word (@PInfDta.LcdStr2),
InfDta.LcdStr2);
    LcdS2 := SLcd
  End;
End
```

The unit UControl contains the functionality of the program. After this program has been compiled, the Delphi Stamp is reset using the onboard switches and the interface server is started. Once the program has started the stepper motor can be controlled.

Other applications

During the design of a prototype of a controller the construction of an instrument panel takes up a lot of time. This involves a number of mechanical operations, such as drilling and deburring the mounting holes for meters, switches, lights, etc. There is an easier alternative, however: the design of a console as a GUI (Graphical User Interface) in Delphi. Usually the same GUI from the previously built simulator can be used.

By starting the M485 server in the firmware, as we did in 'Delphi Stamp as a controller', we can inspect and modify all memory locations via the RS232 port and the M485.dll library. With these facilities it isn't difficult to implement a remotely controlled application. The connection between the PC with the console application and the controller can be made wireless through the use of RS232 radio modules.

More information on the Delphi Stamp may be found at www.vogelaar-electronics.com and www.learningdelphi.info. All source code can be downloaded free of charge from the publishers website: <http://www.elektor-electronics.co.uk/>.

(040240-7)

DON'T LOSE YOUR TEMPER

Before phoning us - if you are looking for a hard-to-find part. We have over 20,000 items in stock - including obsolete and up-to-date parts.



WHY NOT VISIT OUR WEBSITE
www.cricklewoodelectronics.com

2N 2SA 2SB 2SC 2SD 2P 2SJ 2SK 3N 3SK 4N 6N 17 40 AD
 ADC AN AM AY BA BC BD BDT BDV BDW BDX BF
 BFR BFS BFT BFX BFY BLY BLX BS BR BRX BRY BS
 BSS BSV BSW BSX BT BTA BTB BRW BU BUK BUT BUV
 BUW BUX BUY BUZ CA CD CX CXA DAC DG DM DS
 DTA DTC GL GM HA HCF HD HEF ICL ICM IRF J KA
 KIA L LA LB LC LD LF LM M M5M MA MAB MAX MB
 MC MDAJ MJE MJF MM MN MPS MPSA MPSH MPSU
 MRF NJM NE OM OP PA PAL PIC PN RC S SAA SAB
 SAD SAJ SAS SDA SG SI SL SN SO STA STK STR STRD
 STRM STRS SV1 T TA TAA TAG TBA TC TCA TDA TDB
 TEA TIC TIP TIPL TEA TL TLC TMP TMS TPU U UA
 UAA UC UDN ULN UM UPA UPC UPD VN X XR Z ZN
 ZTX + many others

We accept Mail, telephone & email orders.
 Callers welcome.

Opening hours Mon-Sat 9:30 - 6:00



Cricklewood Electronics Ltd

40-42 Cricklewood Broadway London NW2 3ET
 Tel: 020 8452 0161 Fax: 020 8208 1441
sales@cricklewoodelectronics.com

AVIT Research

www.avitresearch.co.uk

USB has never been so simple...



USB to TTL Serial Cable

- Simple and Easy way to give USB support to your designs
- Connects directly to microcontroller UART or I/O pins
- PC communicates as a standard serial device
- All circuitry integrated into sleek, moulded USB plug
- 4-way connector (Gnd, RX, TX and +5v)
- Supplied with PC drivers, example code and tutorial
- Special Price of only 29.99 including VAT

AVIT Research also supply:

I²C Bus Tool - Allows your PC to monitor and control the I²C Bus

- Invaluable tool for developers using the I²C Bus
- See website for full details



www.avitresearch.co.uk

info@avitresearch.co.uk

0870 741 3636



CD-ROM Robotics

A large collection of data-sheets, software tools, tips, tricks and Internet links to assorted robot constructions and general technical information. All aspects of modern robotics are covered, from sensors to motors, mechanical parts to micro-controllers, not forgetting matching programming tools and libraries for signal processing.

Robots built from LEGO® bricks also get a fair amount of attention.

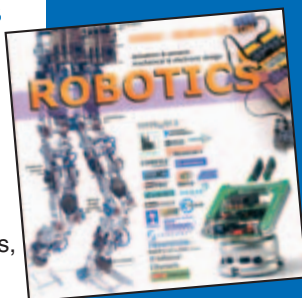

RRP £12.05
 (US\$ 21.25)

Order now using the Order Form in the Readers Services section in this issue.

Elektor Electronics (Publishing)
 P.O. Box 190
 Tunbridge Wells TN5 7WY
 England
 Telephone +44 (0) 1580 200 657
 Fax +44 (0) 1580 200 616

See also www.elektor-electronics.co.uk

EASY COMPONENTS

If only one could buy essential components pre-selected and pre-packed in development friendly sets... We'd all have more time to spend on actually making things.

It's time to get smart about buying components

Fast Components specialise in engineering component kits. They're easy to order, easy to store, and offer exceptional value. Take for example our 1/4 W precision 1% metal film resistor kit - 1080 resistors, 73 E12/E24 values (0Ω - 10MΩ) - £9.99.

Why use surplus / old / aged parts for your prototypes? Brand new component sets make sense!

So what are you waiting for? Ok, ok, here's the icing: as an Elektor reader here's an extra 10% off your purchase, by quoting the promotional discount keyword: EDISON when you place an order by, web, mail, email or phone.

Visit our website or write to us and ask for a free catalogue!

Winchester House, Winchester Road, Walton-on-Thames, Surrey KT12 2RH

www.fastcomponents.co.uk

Tel: 0870 750 4468 Fax: 0870 137 6005

ANDRE LAMOTHE'S
XGAMESTATION
 LEARN STEP-BY-STEP HOW TO BUILD
 AND DESIGN YOUR OWN VIDEO GAME CONSOLE!

Design inspired by the
 Atari 800/2600, Sinclair ZX Spectrum,
 Apple II & Commodore 64!

Includes 33 Key Components!

INCLUDES:

- Tools, Games & Software
- Great for Prototyping AND Students
- The Fun Way to Learn Embedded Systems
- Fully Assembled XGS Video Edition Board
- Complete Software Development Kit
- eBook on Designing the XGS Console
- Cables and Power Supply included!

WWW.XGAMESTATION.COM
 PH: 925.736-2098 | SUPPORT@NURVE.NET

NURVE NETWORKS LLC
 4022 CHANING AVENUE WEST
 DANVILLE, CA 94508 USA

Remote Control Operator

Enhancing remote controlled lightning



Peter Verhoosel

Remote controlled light switches are becoming more and more common. DIY stores have inexpensive sets consisting of several light switches and a remote control unit. It's then easy to control everything from your armchair. But how can you control the lighting when you're away, as a deterrent to burglars? With the help of this little circuit that is no longer a problem.

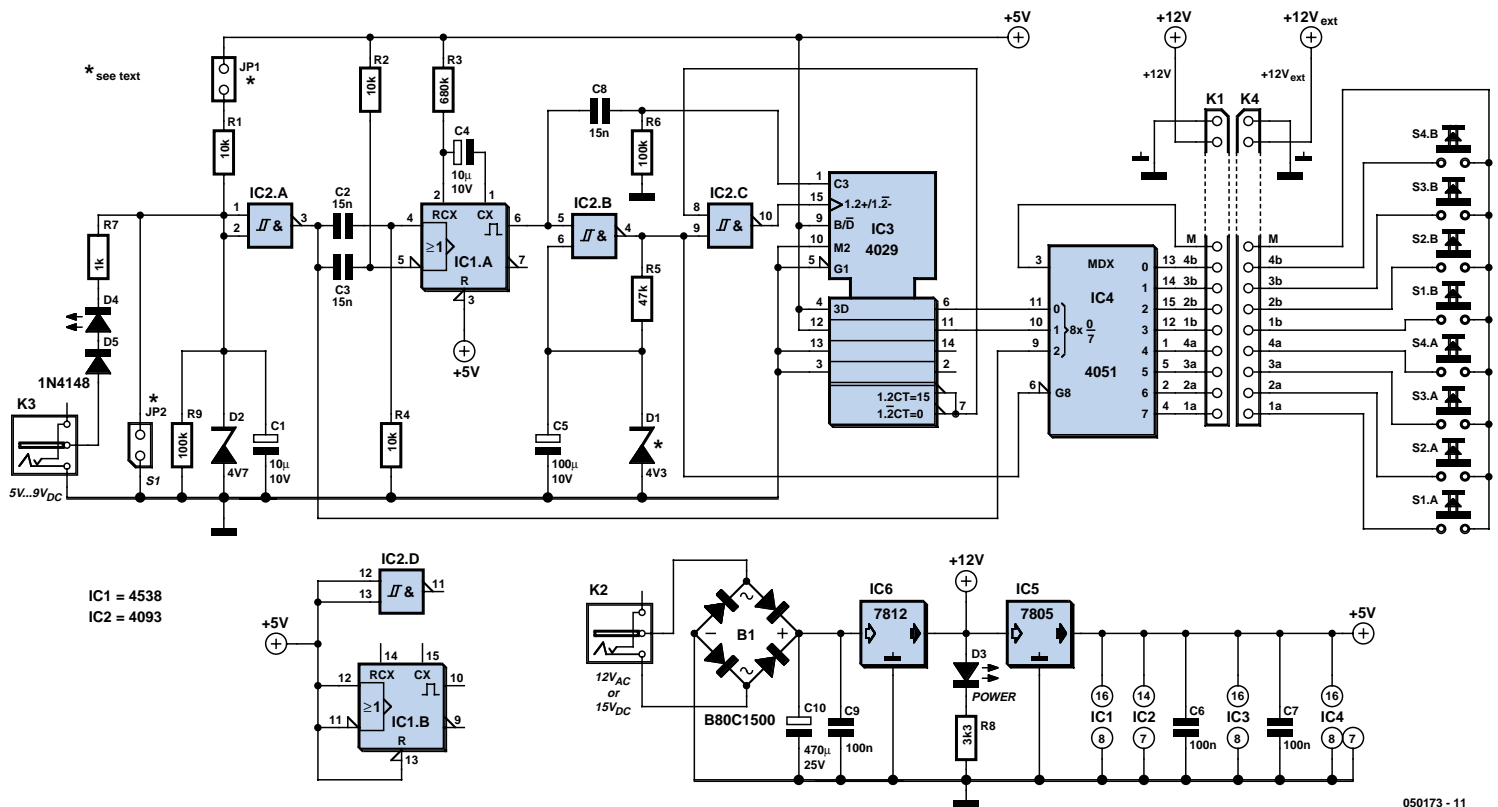

Figure 1. The circuit consists entirely of discrete components.

With modern technology it sometimes happens that you replace one problem with another. Or as Johan Cruyff, the greatest Dutch soccer player of all times eloquently said: "every advantage have its disadvantage". The circuit described here has been designed to overcome a shortcoming of wireless remote controls for domestic lighting.

The problem is this: when people go away on holiday they often connect ordinary lights directly to time switches to turn the lights on and off at certain times.

This gives the impression that the house is still occupied, but it can also come in useful when visitors, who stay till the small hours of the night, need a little hint that it's time to go! But when these lights are controlled wirelessly it is unfortunately no longer possible to switch them on and off with a time switch. The light switches work with a signal that is transmitted via radio or infrared by the remote con-

trol handset. And herein lies the problem: who controls the remote control in your absence?

You can't expect your neighbours to do this for you, even if you get on very well with them. Fortunately, with a little inventiveness and some electronics we can get round this problem.

Electronic control of switches

With this circuit we can add electronic switches in parallel with the buttons in the remote control. Of course your remote control has to be suitable for this modification. This will be covered in detail later, in the section "Modifying the remote control".

To keep things simple, we have catered for a maximum of four lights. The remote control unit we bought had one on-switch and one off-switch for each light. For four lights we therefore need to control eight switches externally.

The receivers are turned on by closing the four 'on' contacts sequentially, with

a short pause in between. They are turned off again by closing the four 'off' contacts sequentially, with a short pause in between.

The circuit

As you can see from **Figure 1**, this time we found a solution without the use of a microcontroller. It does mean that a fair number of components are used in the circuit, but they are all without exception easily obtainable and inexpensive.

In the original design we wanted to control this circuit via an ordinary switch or the switch inside a time switch.

This means that we would first have to open up the time switch to disconnect the internal microswitch from the mains. Apart from the fact that this involves a lot of tinkering, it is not always possible. We would also have to make sure that all safety regulations were adhered to!

It is much simpler to control the circuit

teries are removed before you connect the circuit!

If your remote control doesn't work at 12 V, then all you need to do is to replace IC6 with one that outputs the correct voltage.

Modifying the remote control

As we mentioned earlier, this circuit was designed for use with a specific type of remote control. This circuit will only work with types where one side of the switches is connected to one common track (and the other side of the switches is connected to separate parts of the circuit).

If your remote control unit is the same, you should solder eight plus one wires for the switches and two wires for the supply to connector K4. Then solder the wires to the contacts of the switches. Before connecting this to the circuit you should test that you soldered all wires correctly to the remote control. Short pin 3 (M) of K4 with one of the other pins (1a to 4b) of K4. The remote control should then function just as if you pressed the corresponding key. If it all went satisfactorily you

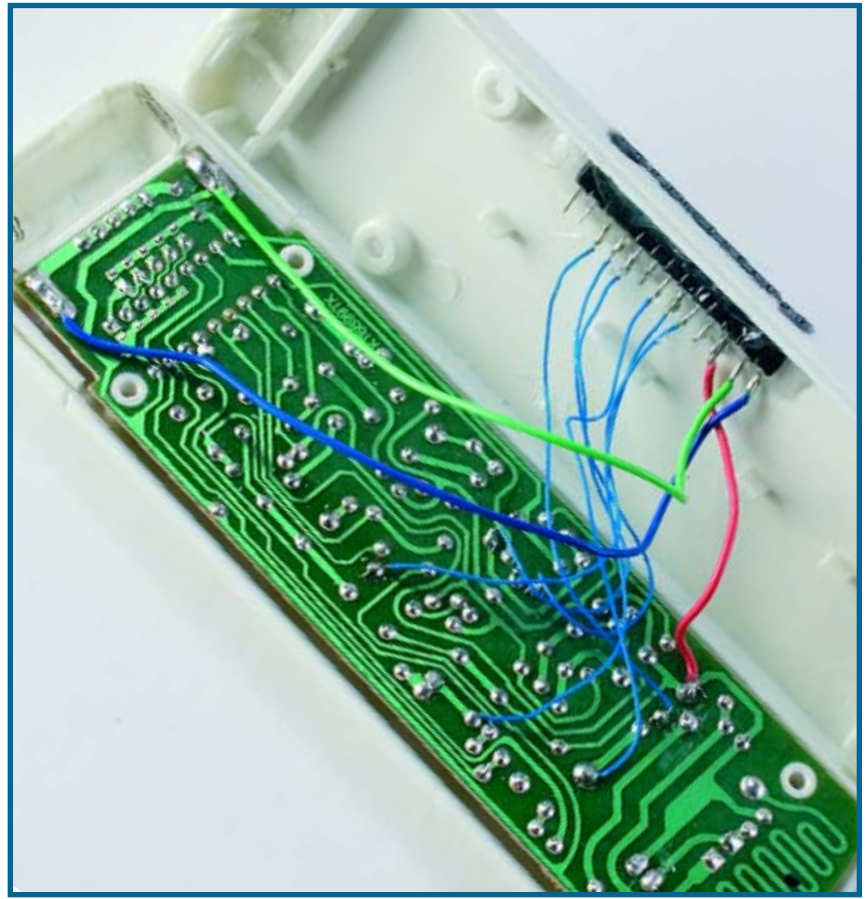

COMPONENTS LIST

Resistors:

R1,R2,R4 = 10k Ω
R3 = 680k Ω
R5 = 47k Ω
R6,R9 = 100k Ω
R7 = 1k Ω
R8 = 3k Ω 3

Capacitors:

C1,C4 = 10 μ F 10V radial
C2,C3,C8 = 15nF
C5 = 100 μ F 10V radial

C6,C7,C9 = 100nF
C10 = 470 μ F 25V radial

Semiconductors:

B1 = B80C1500 bridge rectifier in round case (80 piv, 1.5A)
D1 = zener diode 4.3V 500mW
D2 = zener diode 4.7V 500mW
D3 = LED, red, low current
D4 = LED, red, low current
D5 = 1N4148
IC1 = 4538
IC2 = 4093
IC3 = 4029
IC4 = 4051
IC5 = 7805
IC6 = 7812

Miscellaneous:

JP1 = jumper
JP2 = S1, see text
K1 = 11-way SIL pinheader
K2 = 6-12 V adaptor socket, PCB mount
K3 = 5-9 V adaptor socket, PCB mount
K4 = 11-way SIL socket
Time switch 230V
Mains adaptor 12 V_{AC} or 15 V_{DC}
Mains adaptor 5-V_{DC}
Case, e.g., Hammond type 1591-A
PCB, ref. 050173-1 from The PCBShop

can connect K4 to K1. Don't forget to remove the battery if you use the circuit to provide a power supply to the remote control!

Construction

The construction shouldn't give rise to any problems. In any case, always start with the wire links (including those underneath the ICs).

During the design we had a particular enclosure in mind (see parts list). If you

use the same enclosure you should mount the voltage regulators as close to the board as possible, in order to keep the height to a minimum. It may help if you change the mounting holes to an oval shape with the help of a 1 mm drill.

Connector K1 is used to connect the PCB to the remote control.

It is of course also possible to mount the circuit complete with the mains adaptor and remote control into a dif-

ferent enclosure. Either way, this circuit adds a useful function to your wireless lighting control!

(050173-1)

WiMAX Primer

Wide range wireless access soon to come

Wim Rouwet

Both 802.11 (WiFi) and UMTS/3G are considered mature and more or less mainstream today. UMTS and 3G offer the end-user high levels of mobility and coverage, but lack the support for high throughput low cost data that caused the rise of WiFi — helped by the popularity of both ADSL and cable based broadband connections in the western world. The next logical step in the ongoing quest for more bandwidth and features is addressed by the WiMAX Forum and the 802.16 standard, trying to come up with a wireless broadband data connection offering the coverage of UMTS/3G with the throughput and cost of WiFi. This article addresses some specific design challenges to be considered when developing WiMAX basestations and provides the reader with an introduction to WiMAX.

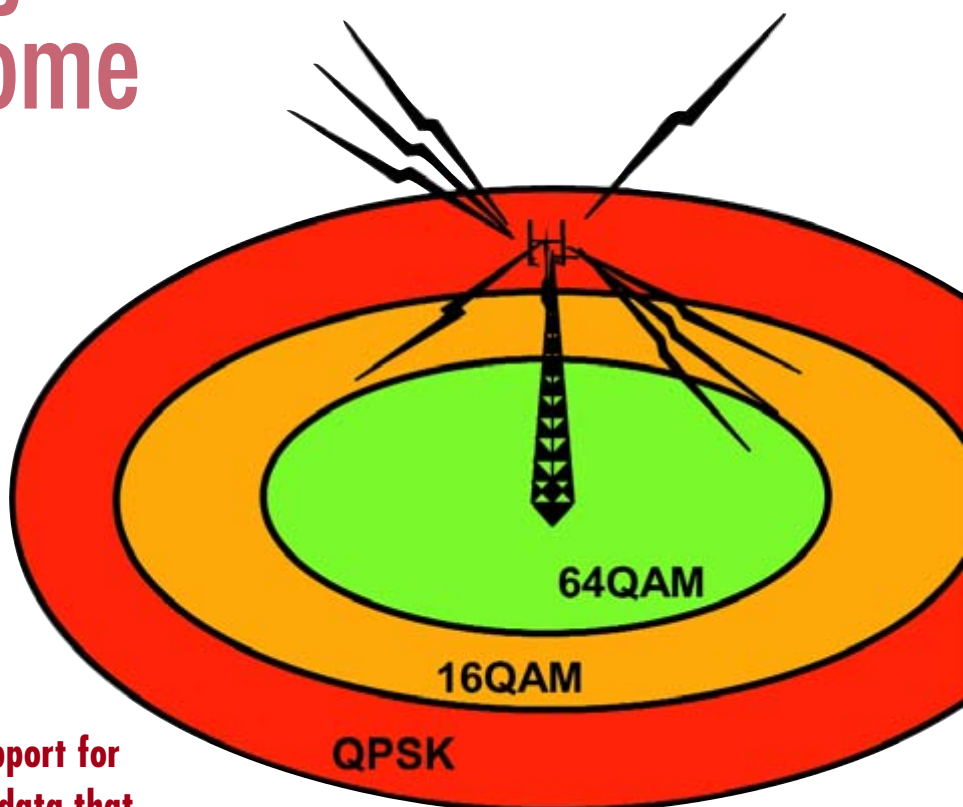

Figure 1. The optimum modulation method depends on channel conditions, which are among others determined by the distance between the terminal and the base station.

The IEEE-defined 802.16 standards are designed to ensure an always-on wireless broadband data connection for both fixed (first generation, 802.16-2004) and mobile (802.16e) users. With the ability to support multiple Quality of Service (QoS) classes, an 802.16 network can support mobile voice, high-speed data, and video in a wireless network. The 802.16 standards are endorsed by the WiMAX (Worldwide Interoperability for Microwave Access) forum. This endorsement ensures both equipment interoperability and promotion of the standard. With the potential to offer three revenue streams from a single IP packet network, the triple play of voice, video, and data is the holy grail of every telecoms operator. IP and a packet switched network are the key enablers towards this goal and in time they will be universal. Designed to support IP, 802.16 can thus benefit the network vendors.

Short introduction to WiMAX

The rapid growth of high speed Internet has led to a huge demand for both residential and business always-on

high speed network connectivity. Although a large percentage of such connectivity is provided by systems such as ADSL, cable modems or even dial-up connections, these forms of connectivity cannot provide service in all areas. For example, the maximum distance that can be covered by an ADSL connection is limited to about 5-6 kilometres, and that only with a strongly degraded connection quality. Cable is not readily available in all countries and a dial-up connection is limited in throughput. The answer to all these problems is Broadband Wireless Access (BWA) which should provide a packet based wireless connection based on the IP protocol with ADSL-level speeds in a cell radius up to tens of kilometres (more info on this later).

The success of BWA has been limited until now. The problem is that although there are many suppliers of BWA, no industry standardized solution has been made available. This has two major disadvantages. First of all, the choice between different solutions is complex due to the differences in feature set and implementation. Second, the user equipment price has remained high as the volume is too low to justify mass-production silicon. By starting the 802.16 working group, IEEE has set the goal to provide a global standard for BWA. The first version of the standard was published in April 2002, with amendments coming out on a regular basis. The role of the WiMAX forum can be compared to that of the Wi-Fi alliance to 802.11: it is not actively involved in the standardization process, but promotes the standard and provides an opportunity for manufacturers to do interoperability testing of their hardware after which it can be sold as 'WiMAX certified'.

There exists a diverse market for BWA systems ranging from backhaul connectivity for (3G) basestations (enabling an operator to interconnect between nodes without using expensive leased lines) to residential and SOHO access where BWA competes with both current (ADSL, cable, dial-up) and future (PON) solutions. BWA is also meant to provide T1+ level leased line type enterprise connectivity with a guaranteed bandwidth and interconnectivity between 802.11 hotspots. Multiple versions of the 802.16 standard exist, but for the applications mentioned above, the so called 802.16-2004 (formerly known as 802.16d) standard is the ratified version as endorsed by the WiMAX forum.

For all above mentioned types of connections, mobility is not required. However, by supporting rapidly changing channel conditions and handovers, the latest revision of the standard (called 802.16e) enables mobile use. By adding mobility support as an add-on to 802.16-2004, a whole new market is opened for operators to offer high-speed IP connections to users that are on the move. This takes the 802.16 standard out of what was designated more or less a niche market into a competitor to the UMTS/3G world. As an example: the Quality of Service support in 802.16 allows for an operator to deploy low-cost Voice over IP (VoIP) telephone handsets enabling a potential flat-rate mobile phone system. Mind that competition for this VoIP market is not only GSM/3G but also 3G evolving standards including HSDPA and HSUPA. The main frequency ranges for 802.16 operation for Non Line of Sight (NLOS) access - where base station and user do not have to 'see' each other to have functional connection — are around 2.4 (US), 3.5 (Europe) and 5.6 GHz. Within these frequencies, only the 5.6 GHz band is unlicensed spectrum. For the other frequencies, operators need to pay a license fee, similar as for 3G licenses. The 802.16-2004 standard is

designed to operate in either a licensed or an unlicensed band, 802.16e only operates in a licensed band. Operation in a licensed band allows the operators to user high transmit power and limits the amount of interference they have to count with due to other transmissions going on in the same band.

The maximum distance from a base station (BS) and a user terminal (Service Station, SS) in 802.16 is in the range of 10 kilometres. This relatively large maximum cell size and the support for NLOS (non-line-of-sight) connections dictates that the modulation method needs to be flexible depending on the quality of the link. The 802.16e standard for example allows any choice between QPSK, 16QAM and 64QAM modulation, see **Figure 1** for the WiMAX fall-back scheme and **Figure 2** for the operation of the three different modulation methods. Modulation type can be changed per user

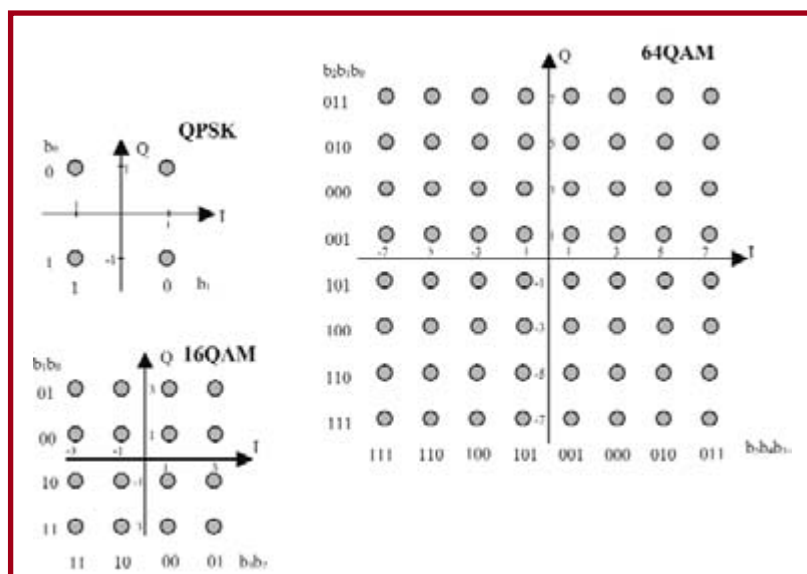

Figure 2. Different modulation methods (QPSK up to 64QAM) used in 802.16e.
For an explanation of terms, see www.blondertongue.com/QAM-Transmodulator/QAM_defined.php

on a frame-by-frame basis to support rapidly changing channel conditions. In ideal conditions (every user gets a 64QAM connection), the maximum throughput of the system is around 38 Mbps using a 10 MHz channel – shared between all (e.g. 256) users of the system. Using a 20:1 oversubscription ratio, this would leave user offered bandwidth of $20 \times 38 / 256 = 3$ Mbps. Operation is allowed in both Time Division (TDD) and Frequency Division (FDD) Duplexing mode, where in TDD the uplink and downlink share one physical (e.g. 10 MHz) carrier, as where in FDD mode, separate carriers are allocated for uplink and downlink, allowing for full-duplex operation. FDD is useful for leased line type of connections in which the downlink and uplink amount of traffic are known to be equal. TDD is the most likely mode of operation in real-life where the downlink traffic is much more than the uplink traffic (this covers the most likely consumer case).

In conclusion, WiMAX has the robustness and flexibility to cope with rapidly changing requirements of LOS as well as NLOS links as illustrated in **Figure 3**.

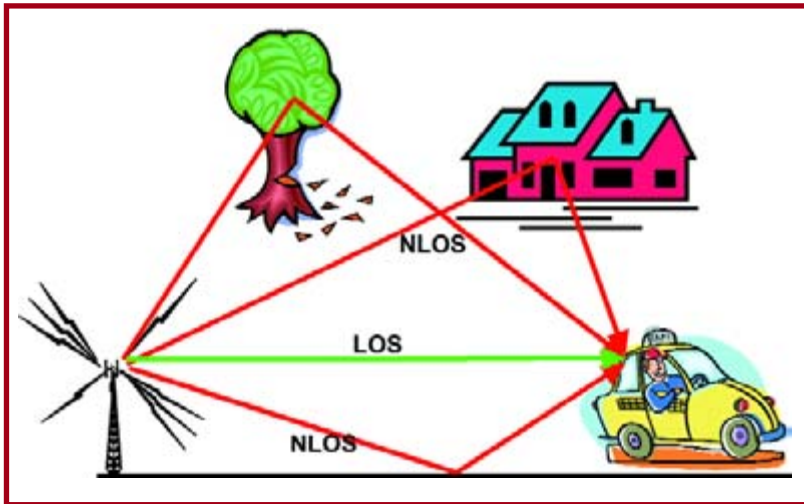

Figure 3. Multipath illustrated. Each path from transmitter to receiver has a slightly different distance, leading to timing differences (distortion) at the receiver.

Payload transmission

A burst that is transmitted through the physical layer can contain any number of serially concatenated PDUs (Protocol Data Units), each consisting of a 6-byte header, a 4-byte (optional) CRC and a arbitrary length payload between header and CRC. In the PDU header, the Connection Identifier (CID) field indicates the connection which the payload is destined for. Each user terminal can have an arbitrary amount of active connections/CIDs (e.g. some management connections, a voice connection and a data connection), and traffic for multiple CIDs can be carried in a single burst as long as all traffic is destined for a single SS. The size of the PDUs is to be determined by the MAC layer and is a tradeoff of the efficiency of the airlink (a large PDU means less overhead of header and CRC) and the chance that the PDU will be lost in flight due to the relatively high Bit Error Rate (BER) of the air interface.

The size of the PDUs is also determined by the payload (Service Data Unit or SDU in 802.16) that is carried. In a typical scenario, the network interface connecting the basestation to the provider network will carry packet based traffic (IPv4/IPv6, PPP, VLAN, Ethernet) although ATM support is also provisioned for. If we assume IP payload carried over a standard Ethernet network, the payload size can be anywhere between 64 and 1500 bytes, which has to be matched somehow by the bursts that are allocated in the physical layer, where it is key to make as

efficient use of the physical layer as possible, hence not wasting any bandwidth (e.g. by using padding). For the purpose of matching the IP payload to be transmitted to the allocated bandwidth on the physical layer, the 802.16 standard supports fragmentation and packing, to either split a large IP packet into multiple fragments which can be transmitted in individual PDUs or to pack multiple small IP packets into a large PDU. The TCP protocol is developed as an end-to-end system to control transport of data over high quality landline links. This form of transport implies 1) a low bit error rate and 2) a small delay. Both these properties are not fully available in an 802.16 system (the BS processing chain puts a delay on the traffic, and an airlink is inherently less reliable than a landline). When in TCP a packet does not arrive at the receiver, the protocol assumes congestion in the network and together with retransmitting the packet, slows down the transmission rate. On an air interface, the packet loss is not necessarily caused by congestion, so the TCP reaction of slowing down the transmission rate is not correct. This negative effect is made worse by a large round trip delay.

Over time, different versions of the TCP protocol have been introduced to overcome this problem, but the core of the issue still exists. The solution offered in modern wireless environments such as HSDPA, HSUPA and also 802.16 is to retransmit packets on the airlink itself, preventing the TCP end-to-end protocol of discovering the packet loss in the first place and hence not impacting the original TCP intended behaviour. The algorithm used for this is called Automatic Repeat Request (ARQ) and works by giving a sequence number to each fixed data size block (e.g. every 10 bytes of payload) and either positively or negatively acknowledging the reception of individual ARQ blocks.

The 802.16 ARQ mechanism can work on either a PDU by PDU basis (in which a complete PDU is retransmitted on indication of an ARQ block loss) or on a block-by-block basis, where individual blocks are retransmitted. The ARQ mechanism can – if needed – re-fragment a previously transmitted fragment on different boundaries for retransmission. The need for this is not immediately obvious (why not simply retransmit a complete PDU?), but becomes clear when looking more detailed at the physical layer. Suppose a connection previously working with 64 QAM modulation is experiencing deep fading and needs to move to QPSK modulation, in parallel dropping a PDU which triggers ARQ. From a MAC perspective, this PDU will still have the same effective size (number of payload bytes) in the retransmission, but from a physical layer perspective (number of OFDMA symbols, number of subchannels), the used area of the PDU in the OFDMA frame will be 3 times the size (QPSK transfers 2 bits per symbol, 64 QAM transfers 6 bits). It might be impossible or unwanted to allocate this amount of physical layer area for the retransmission. Re-fragmentation circumvents this issue.

Quality of service

The most important feature of 802.16 is its support for Quality of Service (QoS). Whereas 802.11 only allows a best effort connection, 802.16 provisions for at least four service classes:

Unsolicited Grant Service (UGS) is designed to support real-time data streams consisting of fixed-size data packets issued at periodic intervals, such as T1/E1, ATM CBR and Voice over IP without silence suppression. Real-time Polling Service (rtPS) is designed to support

Table 1. QoS support in 802.16

	UGS	nrtPS	rtPS	BE
Traffic Priority		X		X
Maximum Sustained Traffic Rate	X	X	X	X
Minimum Reserved Traffic Rate		X	X	
Tolerated Jitter	X			
Maximum Latency	X		X	
Request/Transmission policy	X	X	X	X

A software defined radio implementation

The evolving standards for 802.16 WiMAX change dictate the use of a fully programmable communication-processing platform that can grow with technology. Advancements in signal processing chips allow for such an implementation in which the full processing chain from antenna interface (the interface to the A/D, D/A converter) up to the network interface are implemented in a combination of high performance FPGA or RCF (Reconfigurable Compute Fabric) based antenna processing chips, DSP based solutions for physical layer processing and communication processors for implementing the MAC layer. These solutions target the very low cost end of the market (e.g. pico cells) up to multi-sector macro cells with extensive protocol and interfacing support.

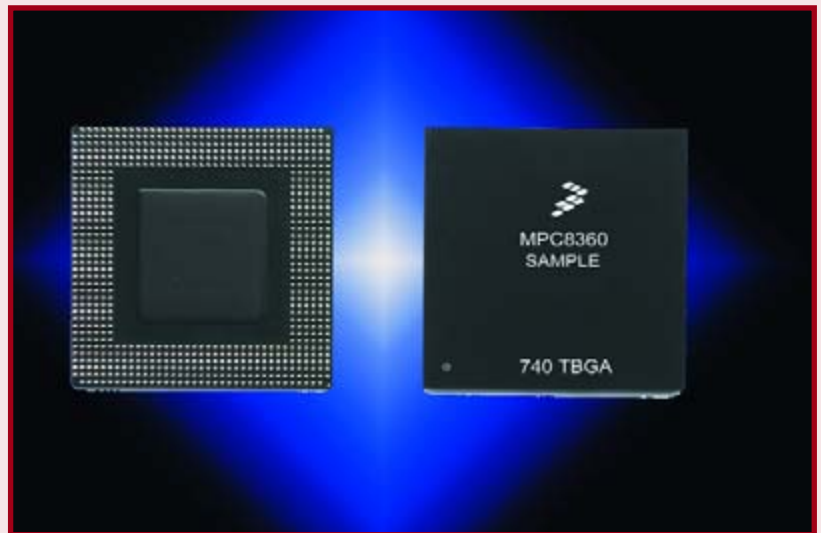

real-time data streams consisting of variable-sized data packets that are issued at periodic intervals, such as MPEG video.

Non-real-time Polling Service (nrtPS) is designed to support delay-tolerant data streams consisting of variable-sized data packets for which a minimum data rate is required, such as FTP.

Best Effort (BE) is designed to support data streams for which no minimum service level is required and therefore may be handled on a space-available basis.

A number of QoS parameters are associated with each of the above service classes as shown in **Table 1**. Apart from these and more given QoS parameters, the standard allows for vendor defined differentiation by leaving one QoS parameter to be defined. All QoS parameters are defined from a user point of view, and hence are not dependent on the specifics of the 802.16 MAC or PHY layer. The network vendor implementation can choose its own algorithms for payload/bandwidth allocation in order to implement (a subset of) the QoS provisionings.

Scheduler Design and MAC interfacing

The scheduling algorithms for uplink and downlink form the core of any 802.16 MAC. Scheduling algorithms must have access to many input parameters such as input queue status and size (in bytes), ARQ data availability and physical layer performance in terms of modulation and channel coding type to be used per user on a given logical subchannel. All such parameters need to be combined with the agreed QoS contracts with the end user and together lead to an optimum scheduling decision. It is obvious that the scheduling algorithms form the core of a vendor defined implementation of the 802.16 base station. It has been shown that through optimum subcarrier allocation per user, the performance of an OFDMA system can be up to 2-3 times better than conventional systems.

Base Station Architecture

The 802.16-2004 and 802.16e standards are still maturing and currently support a large number of options of

which it is unclear if they will be actually used. Ongoing modifications and uncertainty about the options needed for an implementation require a flexible and programmable solution for the network interface, the MAC, the physical layer and the antenna interfacing part (this last part including spectrum shaping, interpolation, soft clipping, digital predistortion, and IQ compensation algorithms). In system design, the designer must decide how to partition the physical and MAC layer processing among the different devices. This decision is challenging due to the large amount of interaction between the 802.16 MAC and physical layers compared to other wireless systems such as 802.11, GSM and various 3G standards. This is mainly dictated by the scheduler design as detailed elsewhere in this article.

Another significant difference between standards such as 802.11, GSM, 3G and 802.16 is the partitioning of the MAC layer. In 3G up to release 99, the full MAC layer still resided in the RNC, but there is a clear trend in the wireless world to move more and more MAC layer complexity to the edges of the network: the base stations. This allows for better QoS control and faster retransmission on packet loss (with as an extreme example the Hybrid ARQ mechanism which is mandatory in HSDPA and optional in 802.16).

Moving the MAC layer processing to the base station means a demand for low-cost high throughput packet processing in each sector linecard. Depending on the physical layer implementation, the MAC chip must also be able to perform specific functions like high-speed encryption/decryption, CRC, HCS calculation which are best implemented in hardware (offload blocks) to lower the processing needs of the physical layer.

Within the MAC layer, the split between the MAC CPS, CS and network layers depends on board/rack, device and interconnect requirements. Protocols, traffic types and traffic volumes used on the network interface vary greatly between different vendors. Such trends push the processing and interfacing demands even further. Inside a base station, the MAC CPS (Common Part Sublayer - responsible for fragmentation, packing, ARQ, encryption, CRCs and QoS) and CS (Convergence Sublayer - responsible for header suppression and classification from e.g. IP to CID) layers can be either implemented in the same device/physical location or split among multiple devices or locations. First, in a multi-sector base station, a possible solution is to implement a single network interface card for MAC CS execution for multiple (up to

OFDMA modulation and frame structure

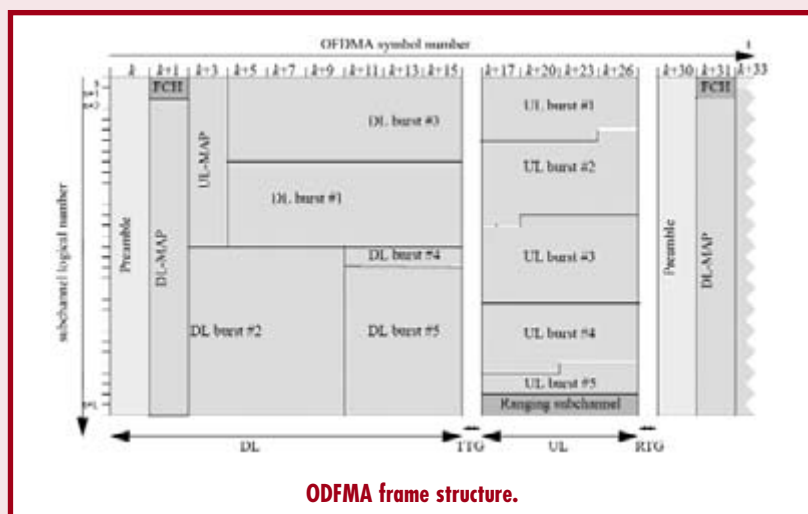

A 'classic' communication channel uses a single carrier frequency where the input bitstream (after channel coding) is modulated with the carrier. The symbol time for such a system can be defined as $1/T$ (T data frequency).

In an ideal world, the received signal equals the transmitted signal, which means that we can decode the transmitted signal by modulating again with the carrier frequency. However, in practice, we have to cope with multipath interference in which the transmitted signal can bounce off the ground, trees, buildings, etcetera before it reaches the receiver. All these different transmissions arrive at the receive antenna at slightly different times, giving 'multipath delay'. If there is multipath delay (characterized by the Channel Impulse Response or CIR), one symbol on the link can interfere with another causing Inter Symbol Interference (ISI). Within limits, ISI can be coped with by implementing a time domain equalizer (channel filter) which compensates for ISI by multiplying the received signal with the estimated channel response.

However, the receive side equalizer complexity increases dramatically when the ISI comes above a certain level. This puts a limit on the maximum bandwidth that can be modulated on a given carrier frequency.

Orthogonal Frequency Division Multiplexing (OFDM) solves the ISI problem in an elegant way. Instead of using a single carrier to transmit the data, multiple parallel carriers are used, hence dividing the available (relatively wide) channel bandwidth (BW – in the case outlined above: 10 MHz) in a set of narrow channels with a spacing of Δf . Compared to a single carrier system, the data rate on each of the channels equals the original rate divided by the number of carriers used. By choosing the symbol rate $1/T$ on each of the subcarriers equal to the frequency spacing Δf , the interference between the different carriers is eliminated.

The implementation of an OFDM system is relatively simple: the conversion from the time domain signal to a multi-carrier frequency signal consists of an Inverse Fourier transform, which means that the main building block of an OFDM system is the FFT and IFFT function – easily implemented on modern high-performance DSPs.

From a high level point of view, the key point of an OFDM system is that the carrier frequency is divided into a large number of subcarriers (802.16 supports up to 2048 subcarriers, in powers of 2), each of which is more or less independent of the others. As an example: the 10 MHz BW that we used above can be divided into 1024 subcarriers of about 10 KHz each. Multiple subcarriers can be grouped together to form logical subchannels.

One can imagine that the performance of a given subchannel to one user will be different to that to another user, as different users perceive a different channel quality based on their individual physical channel conditions. This means that a channel that has bad performance to one user can be favourable to the other. Orthogonal Frequency Division Multiple Access (OFDMA) exploits this feature by allowing to allocate different subchannels to different users over a configurable time part of an air-frame (number of OFDM symbols) as shown in the illustration.

In the picture, a burst is defined as a container for the payload to be transmitted to a certain user terminal. In the downlink, each burst is encoded (e.g. convolutional, LDPC or CTC turbo coding) and modulated (QPSK, 16 QAM, 64 QAM) individually by the physical layer of the base station. In the figure above, this could for example mean that DL burst #1 is modulated with 16QAM and convolutional encoding while DL burst #2 is modulated with 64 QAM and CTC turbo coding, so the amount of bits transferred per OFDMA symbol number/logical subchannel number varies greatly between these two bursts. The location of the burst in the OFDMA frame together with the encoding type of the burst is indicated on a per terminal (user) basis in the DL-MAP, which serves as a 'table of contents' for the frame itself and is transmitted at the start of the frame.

The operation in the uplink is similar to that of the downlink. The base station dictates to each terminal in which location (in terms of OFDMA symbol numbers and subchannels) it is allowed to start a transmission, together with the modulation method to be used.

From the physical layer point of view, a number of actual payload bytes transmitted in a burst is given by the size of the burst (in terms of subchannels and OFDMA symbols) and by the encoding type (which fixes the amount of redundant information added to the payload before transmission).

6) sectors, providing GbE and optional TDM interfaces towards the network carrying data and voice traffic with optional uplink QoS in the form of MPLS or DiffServ. Second, in a single sector base station, the MAC CS and MAC CPS can be run on the same physical device in order to keep the cost low.

tion design for development of high end customer premises equipment — such as super access points — which require a low-cost, low-power and highly integrated silicon solution that provides flexibility to add new features and functions through field software upgrades as market demands dictate in the future.

To push the demands even further in the low end: from a technical perspective, it is possible to re-use the base sta-

Wim Rouwet, (Freescale Semiconductor) wim.rouwet@freescale.com

(050131-1)

Microcontroller Basics

Burkhard Kainka

Microcontrollers have become an indispensable part of modern electronics. They make things possible that vastly exceed what could be done previously. Innumerable applications show that almost nothing is impossible. There's thus every reason to learn more about them, but that raises the question of where to find a good introduction to this fascinating technology. The answer is easy: this *Microcontroller Basics* book, combined with the 89S8252 Flash Board project published by *Elektor Electronics*. This book clearly explains the technology using various microcontroller circuits and programs written in several different programming languages. In the course of the book, the reader gradually develops increased competence in converting his or her ideas into microcontroller circuitry.

ISBN 0-905705-67-X
230 Pages
£18.70 / US\$ 33.70



Step into the fascinating world of microcontrollers

Order now using the Order Form in the Readers Services section in this issue.

Elektor Electronics (Publishing)
P.O. Box 190
Tunbridge Wells TN5 7WY England
Telephone +44 (0) 1580 200 657
Fax +44 (0) 1580 200 616

See also
www.elektor-electronics.co.uk

Flash Microcontroller Starter Kit

Elektor Hardware & Software

Step into the fascinating world of micro-controllers with the Elektor Electronics Flash Microcontroller Starter Kit. Order now the ready-assembled PCB incl. software, cable, adapter & related articles.

Contents of Starter Kit:

- 89S8252 Flash Microcontroller board (ready-assembled and tested PCB)
- 300-mA mains adapter
- Serial cable for COM port
- Software bundle on CD-ROM
- Article compilation on CD-ROM

£ 69.00 / US\$ 112.50
(plus postage)

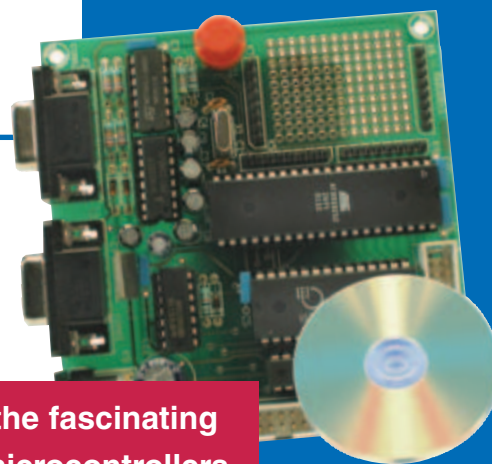

Step into the fascinating world of microcontrollers

Order now using the Order Form in the Readers Services section in this issue.

Elektor Electronics (Publishing)
P.O. Box 190
Tunbridge Wells TN5 7WY England
Telephone +44 (0) 1580 200 657
Fax +44 (0) 1580 200 616

See also
www.elektor-electronics.co.uk

TIRIS RFID Reader

Battery-free RFID tags release unique identity codes

Martin Oßmann

The TIRIS family of RFIDs from Texas Instruments can be found in many consumer applications ranging from vehicle security to logging marathon runner times. The two simple designs described here are able to read these passive RF tags whilst using the absolute minimum of hardware.

There is already an enormous market for contact-less Radio Frequency Identification (RFID) tags. One of the market leaders is the Texas Instruments Registration and Identification System (TIRIS). Each tag is a transponder i.e. a reader unit in close proximity transmits a signal to the tag and it responds by sending back a signal containing its unique identification code. The RFIDs that we have used here are encapsulated passive mini tags available in many different outlines ranging from a chip card to a pet ID implant. A small selection of the devices can be seen in



Figure 1. The author would like to thank Texas Instruments for supplying the components. The purpose of our original investigation was to build a device that could read the low frequency (134.2 kHz) TIRIS family of tags while using the minimum possible hardware outlay (and hence cost). The two circuits described here are the results of this investigation.

A circuit for minimalists: A System on a Chip

The first reader circuit shown in **Figure 2** is about as simple as it gets and consists of little more than a microcontroller together with a transmit/receive coil. The coil connections to the microcontroller in **Figure 3** make use of the input/output programmability of the port pins. The reader software initially configures the pins to output mode and then drives the coil at 134.2 kHz to 'charge up' any tags within range. After this charging period the pins are switched to high impedance mode, effectively disconnecting them from the coil. The coil is now in receive mode and picks-up any return signal from a tag in range. The signal passes to an on-board analogue comparator with resistors R2 and R3 providing the DC reference voltage. Capacitor C1 performs low pass filtering. The trade-off for this minimal hardware approach is that the software has more work to do and is correspondingly more complex. An overview of all the software routines is shown in **Figure 5**.

Transmitting and receiving

The microcontroller uses a 12 MHz crystal oscillator. The charging signal sent to the RFID is a alternating field at a frequency of 134.2 kHz and this cannot be divided down from the 12 MHz microcontroller clock very easily. A 'software oscillator' technique is borrowed from the field of Direct Digital Synthesis (DDS) whereby a clock is produced by counting alternatively 89 and 90 periods of the 12 MHz source so that we arrive at an average division factor of 89.418... The spectral purity of the resultant signal is sufficient to ensure good energy transfer to the tag. When sufficient charge has been stored in the tag reservoir capacitor a stream of data is transmitted containing a identity 'key' unique to the tag. The digital information is sent using frequency modulation where 134.2 kHz represents a '0' and 123.2 kHz a '1'.



Figure 1. TIRIS tags come in many variants.

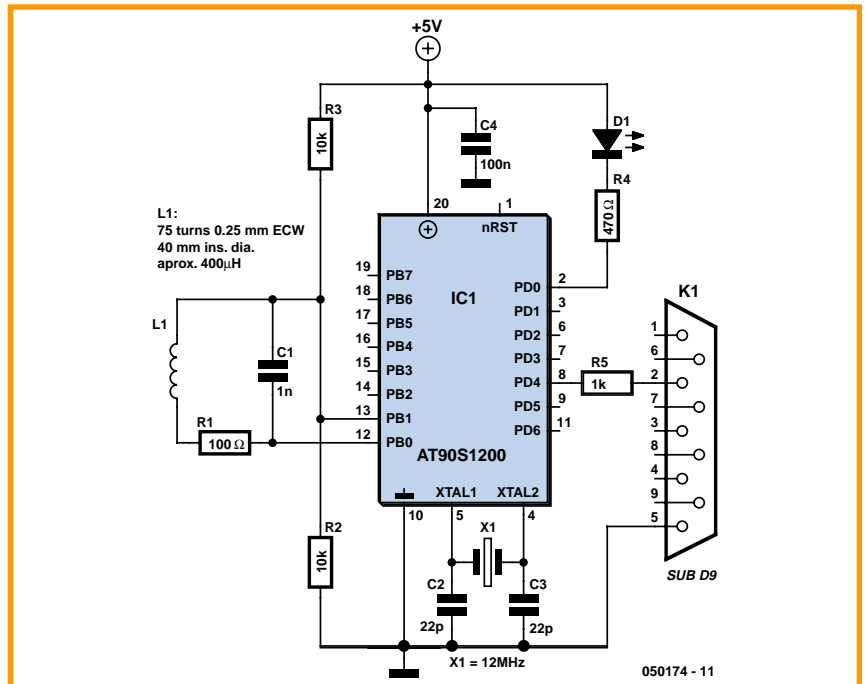

Figure 2. The simplest TIRIS reader.

Each bit length occupies 16 periods of the modulation frequency. The signal is picked up by the reader coil and fed to an internal comparator to generate an interrupt for each period of the signal. An internal counter is then used to measure the time between each interrupt. Measurements from several periods are then averaged to provide some low pass filtering. For the purposes of testing these counter values are also

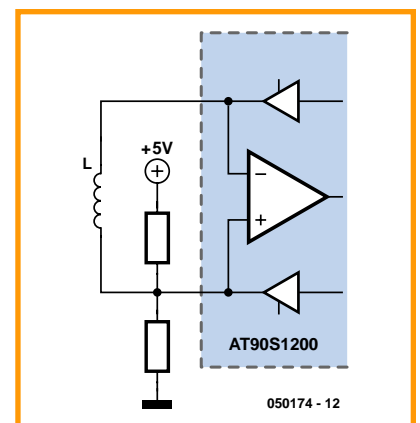

Figure 3. Bi-directional coil to microcomputer connections.

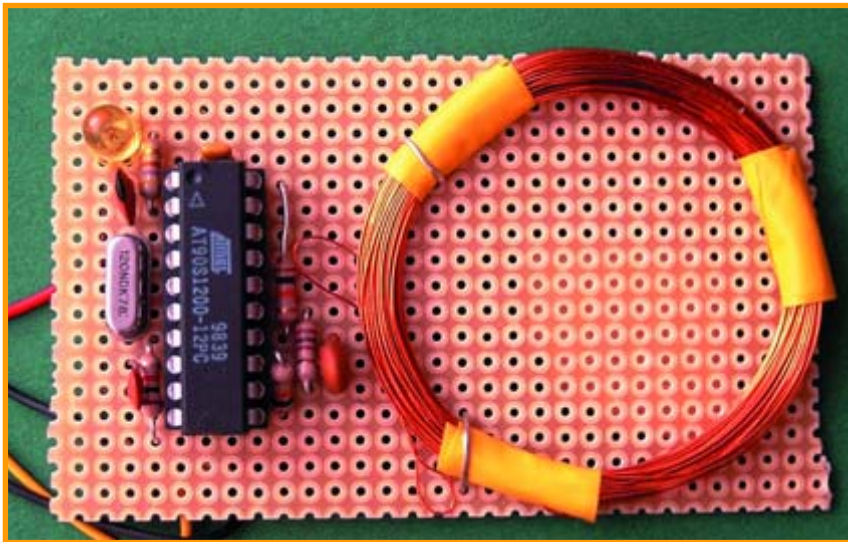

Figure 4. Layout of the minimal version.

output on the highest six bits of port B of the processor. It is a simple job to connect a D/A converter to these pins and display the resulting analogue out-

put signal on an oscilloscope. This provides a convenient and useful indication of the proper function of the receiver as shown in **Figure 6**. The

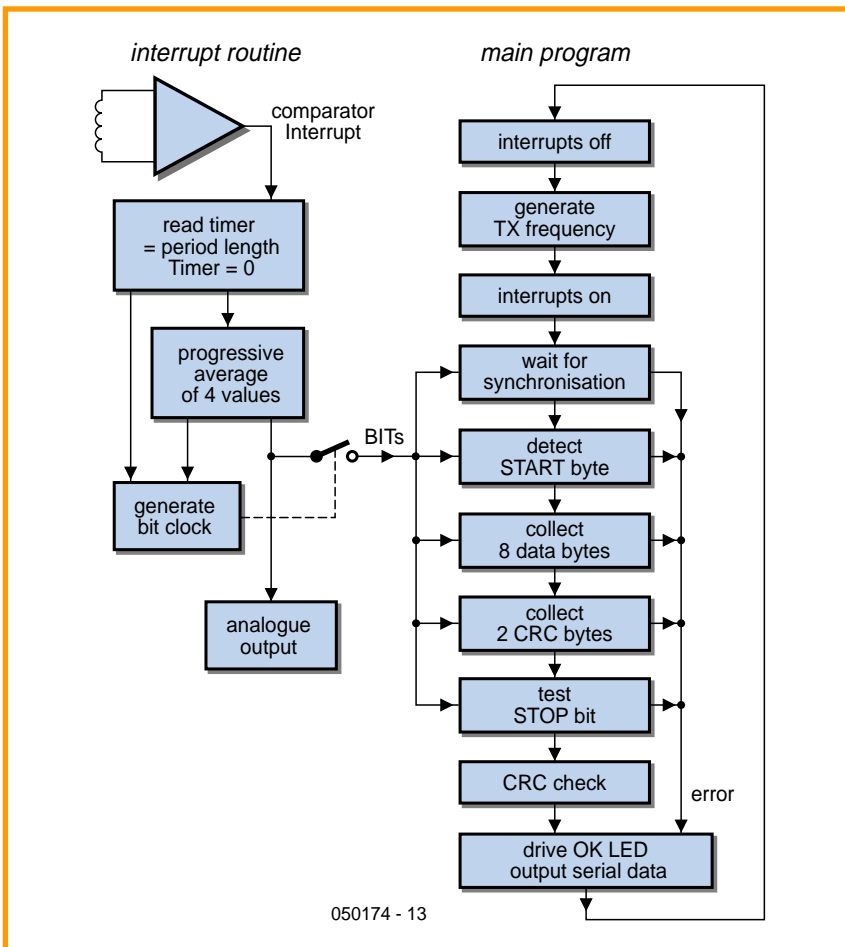

Figure 5. The software structure.

upper trace shows the RF field detected by a test coil placed close to the transponder. The (delayed) trigger point is chosen when the reader stops sending its 'charging' signal on the left of the screen after this point we see the modulated tag signal which has a characteristic diminishing amplitude, reducing as the stored energy is used up. The lower trace shows the recovered data from this signal. Each bit read in the interrupt routine after the valid START bits is reassembled into bytes and stored. A TIRIS tag sends eight bytes of data followed by a two-byte checksum or CRC (Cyclic Redundancy Check). The checksum is verified by software along with the termi-

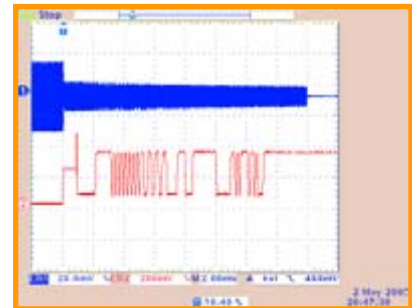

Figure 6. The RF signal and recovered data.

nating STOP byte. If no error is detected the OK LED lights and the receive data is sent out from the RS232 port at a rate of 9600 bits/s. If an error is detected the OK LED remains off and a question mark character is sent out from the RS232 port.

With all the functions built into the software this basic reader circuit is a good starting point for many useful applications but the tag needs to be quite close to the reader to ensure reliable reading. If more range is required then a slightly more sophisticated circuit is necessary.

Boosting the range

The minimalist circuit diagram has been expanded slightly (**Figure 7**) to incorporate a better coil driver stage together with a signal amplifier in the receive path. The coil switching configuration is shown in **Figure 8**.

When the reader transmits, transistors T1 and T2 operate in push-pull mode to drive the series resonant circuit formed by C1 and L1. The circuit has a Q (quality) factor of around 10 and is defined largely by the P-channel BS250

Flash Lock for PCs

Brains instead of brawn

Anthonie Botha

This system was designed to eradicate the anarchy that reigned on a school's computers. Conventional password protection could not be utilized and the old key lock was too easily tampered with and bypassed. Highly objectionable information was being downloaded from the Internet and files being deleted all the time. To no avail, the guilty party was always conveniently dead or in hyperspace! A failsafe physical lock was urgently needed with total control and hence the Flash PC Lock was born!

The PC Flash Lock device should have a lot of applications. For example, the author implemented this lock at a friend's Internet café. Also, a small software company employs this versatile lock together with an OCX incorporated into their software to prevent pirating and multiple software installations. The author himself employs it on his PC's to prevent his children from giving him heart failure when they "accidentally" destroy valuable source code. The software controlling the Flash Lock is a resident utility, hiding in the root of the operating system and waking up on startup. It also interfaces with the Flash Lock hardware via the serial port, exchanging data every second. For the person that is fanatical about security of his or her files, this is a cost effective solution.

After an error, the system will shut-down (if that option was selected) allowing you 60 seconds to attempt to solve the problem. Instead of shutting your PC down, you can merely remove the Flash Lock. **The device works on Windows XP machines only.**

How does it work?

By using your computer, an open serial port and the Flash Lock software, writ-

ten with Visual Basic 6 there are various options at your disposal.

The circuit is very basic and will fit into a standard 9-pin serial port plastic housing. A hole can be made in the plastic housing and the Flash Lock fitted to a key ring. As you may have guessed at this point, the power behind the circuit is the software.

Hardly hardware

The circuit diagram of the PC Flash Lock, **Figure 1**, is down to a microprocessor, some passive parts and diodes. The supply voltage to the microprocessor is limited to about 5.6 V by zener diode D2. As the RS232 port is specified to supply an internally limited maximum 20 mA of line current, no series resistor is required to keep the zener diode and the (PIC) from harm. The other diode in the circuit, D1, prevents the PIC supply voltage from becoming negative. The PIC I/O pins being used by the software are protected by 1-k Ω resistors. Admittedly that's close to what a PIC can take for abuse but then the circuit has to remain as simple and cheap as possible. Knowing from the PIC datasheets that the pins can sink or source up to 20 mA each, we get

$12\text{ V}/1,000\ \Omega = 12\text{ mA}$ under worst case conditions so it's cheeky but still within spec. This excess current will flow from the VDD or the GND pin, the zener diode acting as a sink.

The oscillator inside the PIC16F628A-SO chip operates at the frequency governed by an external 4-MHz ceramic resonator, X1.

Construction — wick it!

The tiny printed circuit board designed for the Flash Lock is shown in **Figure 2**. With some force and possibly some strong words it can be pushed between the pins of a 9-way sub-D socket (yes that's the female version). Check if the case fits around the tiny board and if necessary trim the sides by filing.

If you hate SMDs, you should know that the PIC chip also exists in a DIP case, hence the circuit may also be built on a piece of veroboard. You will, however, have a hard time fitting the lot in a 9-way sub-D connector shell.

A lot has been said and written on the subject of soldering SMD parts and some advice is repeated here for the benefit of beginners.

Absolute requirements for success in the SMD department include good quality tools, a clean desk and a steady



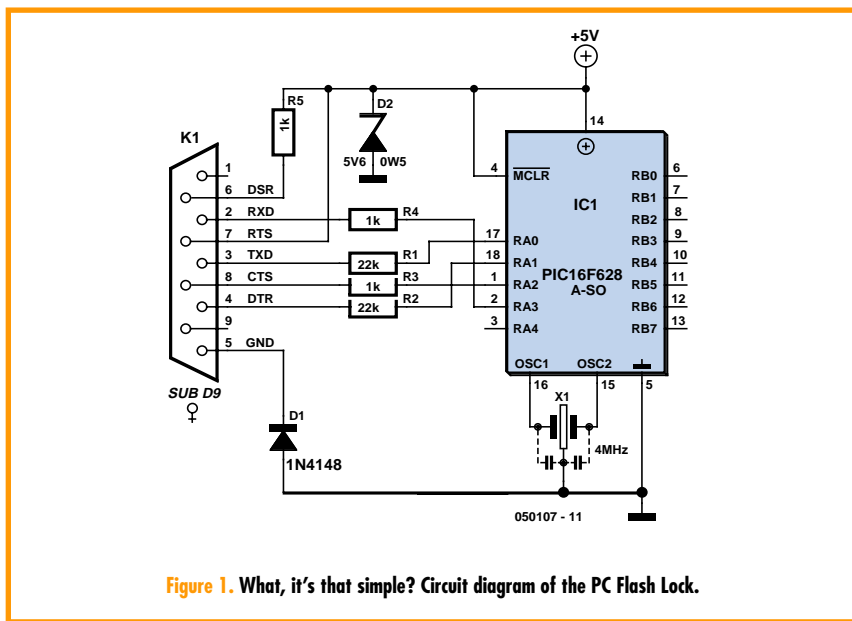

Figure 1. What, it's that simple? Circuit diagram of the PC Flash Lock.

hand. We'll shortlist some more aspects below.

- Use a low-power solder iron with a tip diameter of 1 mm maximum. Alternatively, use a larger tip and wind 1-mm solid copper wire around it.
- The same applies to the solder tin — use the thinnest you can get — 0.6 mm or 0.5 mm is recommended.
- Precision tweezers from specialised pharmacists — much smaller and accurate than the 'pair of tongues' you normally get at Woolworth's.
- Desoldering braid (a.k.a. *wick*), if necessary with its suction power boosted by a bit of colophonium.
- Fit the 0805-case components by first generously tinning one PCB pad. Using the tweezers and the solder iron, position the part and secure one end by pushing it into the solder. No extra tin is required at this point. Next, solder the other end. If necessary, reflow the solder at the first end.
- The IC is first aligned on its footprint, then secured by soldering one corner pin. Check the alignment of the other pins. If ok, solder the pin at the other side of the chip, and so on. Do not panic if adjacent pins get interconnected by excess solder — remove the solder by applying a length of fresh wick.

Finally, inspect your work using a magnifying glass. Tell your friends about it.

The software

The simplicity of the PC Flash Lock hardware belies the sheer power and complexity of the associated software developed by the author.

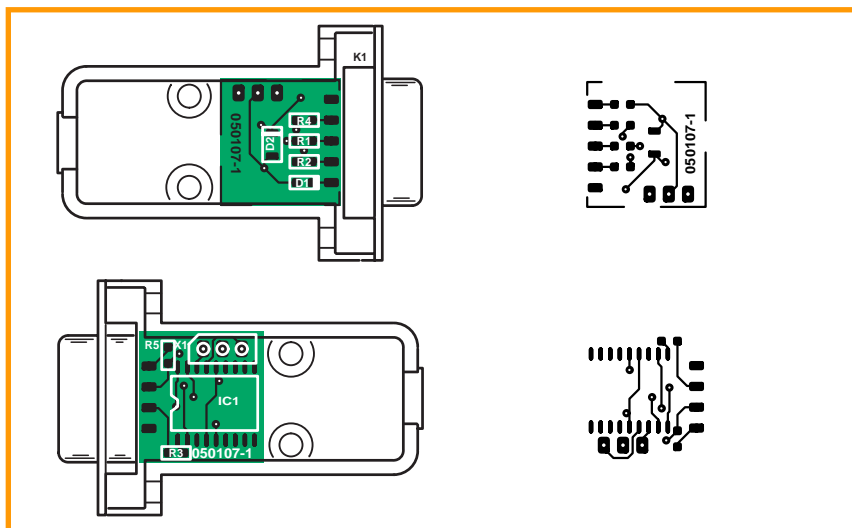

Figure 2. Copper track layout and component mounting plan of the miniature PCB designed for the PC Code Lock.

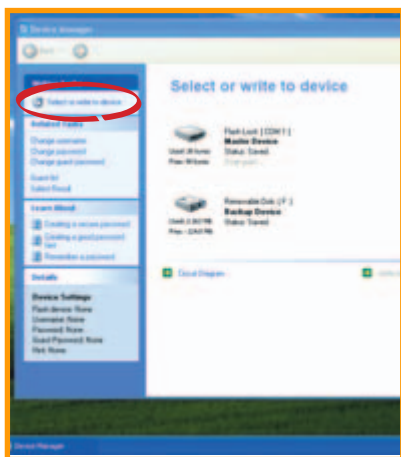

Figure 3. The first option in the PC software (device manager) allows you to read or change your username and password. This password is written to the EEPROM using “write to device”.

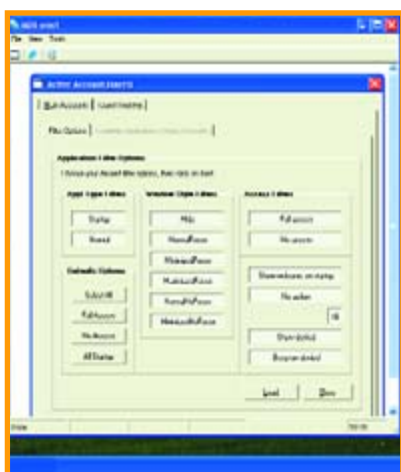

Figure 4. The fourth option (application manager) allows you to manage individual rights. The fourth option (application manager) allows you to manage individual rights.

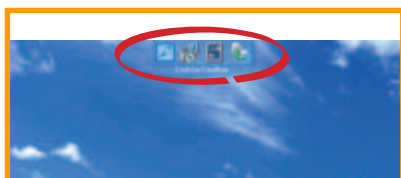

Figure 5. After software installation, the Elektor Toolbar will be installed in the top of the screen. Left or right clicking on the icon will display the Accounts menu.

The complete *Software Guide* available for this project comes as a free download (no. **050107-12.zip**). It is 21 pages in all, and comprehensive by any standard, covering not only everyday use

COMPONENTS LIST

Resistors:
(all SMD, 5%, case shape 0805)
R1,R2 = 22kΩ
R3,R4,R5 = 1kΩ

Semiconductors:
D1 = 1N4148, SMD, case shape 0805
D2 = zener diode 5.6V 500mW, SMD, MiniMelf case
IC1 = PIC16F628A-I/SO, SO18 case,

programmed,
Publishers order code **050107-41***

Miscellaneous:
K1 = 9-way sub-D socket (female), straight pins
9-way sub-D connector shell case PCB, ref. 050107-1 from The PCBShop CD-ROM, PIC source and hex code files, PC resident software, Publishers order code **050107-81*** or free download (approx. 20 MB)
Flash PC Lock Software Guide, free download # **050107-12.zip**

* See Elektor SHOP pages or www.elektor-electronics.co.uk

but also advanced items like URL history storage and File Encryption. The *Software Guide* comes as a page-indexed Word document. What’s conveniently called ‘software’ here actually consists of two components: (1) PIC-resident software and (2) PC-resident software.

The **PIC software** is available as an .asm or .hex file. Provided you have a programmer for SOIC PICs you can burn your own device at home or at school. If not, you will have to rely on our Readers Services by ordering a ready-programmed PIC (order code **050107-41**). The PIC configuration bits, so often a source of confusion to our readers, are given in the *inset*. This software allows the PC to check, at 1-second intervals, for the presence of the Flash Lock dongle, or, more accurately, for the right code in the PIC’s EEPROM memory.

The **PC software** is a massive 20 MB of tools and an installation program supplied on a CD-ROM, order code **050107-81**. Alternatively, if you’re on broadband Internet, the PC software may also be downloaded from our website.

An impression of the PC Flash Lock software in action is given by **Figures 3, 4 and 5**. As you can see, there are lots of options to enable you to adapt this project to your specific needs.

Once installed on the PC, the resident Flash Lock utility will display a small, semi-transparent toolbar at the top of the screen. This will give access to all functions including accounts management and passwords. The software has a 10-digit ASCII password, 10-digit user name, 10-digit guest password and a 20-digit password hint.

The dongle may be plugged into the COM1 or COM2 RS232 serial port on

your PC and is automatically found by the software. In some cases, however, you will need to use the ‘scan ports’ option to locate the RS232 port with the dongle on it.

The program provides a one-time offer to create a rescue disk and produce hard copy of essential data.

Famous last words

Finally, a word of caution: we sincerely recommend installing and using the Flash Lock device and control software on a ‘scrap’ Windows XP PC that’s not essential to serious work. By no means install the device on a PC that’s required for daily use, as even a small mistake in the PC Lock configuration will permanently bar you from access to all your files and programs! Yes, it happened to us while engineering this project towards publication. Forewarned is forearmed!

(050107-1)

PIC bit options

The PIC16F628A-SO to be used in this project needs to have its configuration bits programmed as shown below.

0	F OSC0	1	xt oscillator
1	F OSC1	0	xt oscillator
2	WDTE	0	watchdog disabled
3	PWRTE	0	powerup timer enabled
4	F OSC2	0	xt oscillator
5	MCLRE	0	memory prot off
6	BOREN	1	brownout enabled
7	LVP	1	low voltage program enabled
8	CPD	1	data memory protection off
9			
10			
11			
12			
13	CP	1	code memory protection off



Quasar Electronics Limited
PO Box 6935, Bishops Cleeve
CM23 4WP, United Kingdom
Tel: 0870 246 1826
Fax: 0870 460 1045
E-mail: sales@quasarelectronics.com
Web: www.QuasarElectronics.com

Postage & Packing Options (Up to 2Kg gross weight): UK Standard 3-7 Day Delivery - £3.95; UK Mainland Next Day Delivery - £8.95; Europe (EU) - £6.95; Rest of World - £9.95

Order online for reduced price UK Postage!

We accept all major credit/debit cards. Make cheques/PO's payable to Quasar Electronics. Prices include 17.5% VAT. Call now for our FREE CATALOGUE with details of over 300 kits, projects, modules and publications. Discounts for bulk quantities.



QUASAR
electronics
Get Plugged In!

0871 CREDIT CARD SALES 717 7168

Motor Drivers/Controllers

Here are just a few of our controller and driver modules for AC, DC, unipolar/bipolar stepper motors and servo motors. See website for full details.

NEW! Bidirectional DC Motor Controller

Controls the speed of most common DC motors (rated up to 32VDC/5A) in both the forward and reverse direction. The range of control is from fully OFF to fully ON in both directions. The direction and speed are controlled using a single potentiometer. Screw terminal block for connections. Kit Order Code: 3166KT - £14.95
Assembled Order Code: AS3166 - £24.95

DC Motor Speed Controller (5A/100V)

Control the speed of almost any common DC motor rated up to 100V/5A. Pulse width modulation output for maximum motor torque at all speeds. Supply: 5-15VDC. Box supplied. Dimensions (mm): 60Wx100Lx60H. Kit Order Code: 3067KT - £11.95
Assembled Order Code: AS3067 - £19.95

NEW! PC / Standalone Unipolar Stepper Motor Driver

Drives any 5, 6 or 8-lead unipolar stepper motor rated up to 6 Amps max. Provides speed and direction control. Operates in stand-alone or PC-controlled mode. Up to six 3179 driver boards can be connected to a single parallel port. Supply: 9V DC. PCB: 80x50mm. Kit Order Code: 3179KT - £9.95
Assembled Order Code: AS3179 - £16.95
Assembled Order Code: AS3113 - £24.95

NEW! Bi-Polar Stepper Motor Driver

Drive any bi-polar stepper motor using externally supplied 5V levels for stepping and direction control. These usually come from software running on a computer. Supply: 8-30V DC. PCB: 75x85mm. Kit Order Code: 3158KT - £12.95
Assembled Order Code: AS3158 - £26.95

Most items are available in kit form (KT suffix) or assembled and ready for use (AS prefix).

Controllers & Loggers

Here are just a few of the controller and data acquisition and control units we have. See website for full details. Suitable PSU for all units: Order Code PSU445 £8.95

Rolling Code 4-Channel UHF Remote

State-of-the-Art. High security. 4 channels. Momentary or latching relay output. Range up to 40m. Up to 15 Tx's can be learnt by one Rx (kit includes one Tx but more available separately). 4 indicator LED's. Rx: PCB 77x85mm, 12VDC/6mA (standby). Two and Ten channel versions also available. Kit Order Code: 3180KT - £41.95
Assembled Order Code: AS3180 - £49.95

Computer Temperature Data Logger

4-channel temperature logger for serial port. °C or °F. Continuously logs up to 4 separate sensors located 200m+ from board. Wide range of free software applications for storing/using data. PCB just 38x38mm. Powered by PC. Includes one DS1820 sensor and four header cables. Kit Order Code: 3145KT - £19.95
Assembled Order Code: AS3145 - £26.95
Additional DS1820 Sensors - £3.95 each

NEW! DTMF Telephone Relay Switcher

Call your phone number using a DTMF phone from anywhere in the world and remotely turn on/off any of the 4 relays as desired. User settable Security Password, Anti-Tamper, Rings to Answer, Auto Hang-up and Lockout. Includes plastic case. Not BT approved. 130x110x30mm. Power: 12VDC. Kit Order Code: 3140KT - £39.95
Assembled Order Code: AS3140 - £49.95

Serial Isolated I/O Module

Computer controlled 8-channel relay board. 5A mains rated relay outputs. 4 isolated digital inputs. Useful in a variety of control and sensing applications. Controlled via serial port for programming (using our new Windows interface, terminal emulator or batch files). Includes plastic case 130x100x30mm. Power Supply: 12VDC/500mA. Kit Order Code: 3108KT - £54.95
Assembled Order Code: AS3108 - £64.95

Infrared RC Relay Board

Individually control 12 on-board relays with included infrared remote control unit. Toggle or momentary. 15m+ range. 112x122mm. Supply: 12VDC/0.5A
Kit Order Code: 3142KT - £41.95
Assembled Order Code: AS3142 - £51.95

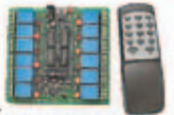

PIC & ATMEL Programmers

We have a wide range of low cost PIC and ATMEL Programmers. Complete range and documentation available from our web site.

Programmer Accessories:
40-pin Wide ZIF socket (ZIF40W) £15.00
18V DC Power supply (PSU010) £19.95
Leads: Parallel (LDC136) £4.95 / Serial (LDC441) £4.95 / USB (LDC644) £2.95

NEW! USB 'All-Flash' PIC Programmer

USB PIC programmer for all 'Flash' devices. No external power supply making it truly portable. Supplied with box and Windows Software. ZIF Socket and USB Plug A-B lead not incl. Kit Order Code: 3128KT - £34.95
Assembled Order Code: AS3128 - £44.95

Enhanced "PICALL" ISP PIC Programmer

Will program virtually ALL 8 to 40 pin PICs plus a range of ATMEL AVR, SCENIX SX and EEPROM 24C devices. Also supports in System Programming (ISP) for PIC and ATMEL AVRs. Free software. Blank chip auto detect for super fast bulk programming. Available in assembled format with ZIF socket only. Assembled Order Code: AS3144ZIF - £64.95

ATMEL 89xxxx Programmer

Uses serial port and any standard terminal comms program. 4 LED's display the status. ZIF sockets not included. Supply: 16-18VDC. Kit Order Code: 3123KT - £29.95
Assembled Order Code: AS3123 - £34.95

NEW! USB & Serial Port PIC Programmer

USB/Serial connection. Header cable for ICSP. Free Windows software. See website for PICs supported. ZIF Socket/USB A-B lead extra. Supply: 18VDC. Kit Order Code: 3149CKT - £34.95
Assembled Order Code: AS3149C - £49.95



www.quasarelectronics.com

Secure Online Ordering Facilities • Full Product Listing, Descriptions & Photos • Kit Documentation & Software Downloads

The Noiseless

It's great that PCs are becoming faster all the time but on the downside they're also producing more heat and noise. Several solutions have been devised to keep the innards of a PC as cool as possible, the simplest method being air flow cooling. However, from the noise produced it sometimes seems as if the PC is on a runway ready to take to the skies! Water cooling is a lot quieter but what if the system springs a leak? So what about oil cooling? It looks like the perfect workaround, but then...

Thijs Beckers

Triggered by a message somewhere on the Internet we had a look at Markus Leonhardt's website [1]. Markus had the wherewithal to immerse his PC system (excluding case) in an aquarium-size container filled with vegetable oil from the supermarket. The PC works! Oil does not conduct, so no short-circuits are created. According to Markus, the PC is now totally quiet. He left the fans in place; they are still running albeit much slower than in air. This of course helps the relevant components to transfer heat to the oil. The power supply has also been sunk in the oil bath — quite risky but no fatal events so far. The hard disk and CD/DVD drives are running outside of the oil bath. In the case of the CD/DVD drive we can understand why, but why not drop the hard disk into the bath, too? After all, most of today's hard disks are fairly noisy as well as running quite hot so oil cooling would seem ideal. Still, we had our doubts. There was only one way to find out what would happen if...

After some deliberation in the lab we gathered some computer junk and started testing. The first guinea pig was an old Seagate 100 MB hard disk. Normally a fairly noisy disk, the veteran could hardly be heard once immersed in our oil bath. The disk remained active all day, apparently without problems. However, the next day, on starting the system, it soon transpired that the hard disk had 'drowned', the PC's BIOS faithfully reporting a fatal error in the hard disk department! Even after allowing the excess oil to leak from the drive, the little



motor was no longer capable of spinning the data discs at the required speed. This, in turn, causes the heads to scrape across the disc surface, which is of course a 'terminal' fault condition — it's goodbye to *ye olde* Seagate 100 MB.

On opening the disk drive the problem was soon discovered: oil! It must have crept in along a minuscule opening around the flatcable connecting the control board to the heads. Another 'suggested cause of malfunction' was oil having soaked the foam sealing protecting the disc compartment and eventually leaking through. This, at the end of the day, is causing the problems. After all, the hard disc requires air to make the heads hover just above the disk surface [2]. Once the disk surface is contaminated with an oil film, the disk is slowed down by friction, causing the air gap between the head and the disk to disappear, so eventually, the head touches the disk surface. This of course spells the end of the hard disc. The second hard disk to be tried was a Quantum with a once impressive 128 MB of storage space. It still worked after a week or two in the oil bath.

The one conclusion to draw from this lab experiment is not to immerse your hard disk in an oil bath if you are keen on keeping the data on it. The risk is too high — it may fail, or not (as in the case of the Quantum HD). In any case, there is no guarantee that the hard disk will remain functional.

PC

Drastic measures: PC in an oil bath



It is just possible to think of a system that precludes direct contact between the disk and the oil, but still allows vibrations produced by the hard disk to be damped by the liquid. Ideally, the heat should also be dissipated properly. During an editorial meeting, when this article was discussed, some really wild ideas were suggested involving engine oil and special constructions.

In the forum of the website at [3] the suggestions include covering the PC electronics in silicone mastic and fitting a huge heatsink. One intrepid forum reader even asked the IBM helpdesk for advice on whether or not a vent hole could be taped off, and, if not, how much air would be required to keep the disk going. Although it was said that the operation of the hard disk would be compromised by sealing off the hole,

IBM kindly stated that about 0.5 cm³ of air was sufficient for sustained operation.

Alternative solutions proposed include the use of drinking straws, little tubes etc. allowing the disk to breathe air from above the oil. A lot of tinkering with great risks of a leak somewhere in the piping.

What do computer builders think of the idea? At the HP helpdesk, a sudden silence and perplexed staff. After a lot of searching, one staff member was finally found willing to forward our query to several departments. Unfortunately no answers came in before our deadlines. No conclusive answers either from PC motherboard manufacturers, like, for example, MSI whom we approached through their distributors. Apparently no one was able to tell if continuous contact with oil would affect various components and/or materials used on the board (like the motherboard plastic or the ICs).

If this idea for enhanced PC cooling spreads as fast as we noticed these past few weeks, it will not be long before the first Pentium-4 EE with Geforce 6800 Ultra in SLI configuration will find its way into a bath of Tesco's vegetable oil. Quite possibly, oil-sealed enclosures will become available, made of transparent Plexiglass, of course, so the lot can be illuminated with colourful lights. "I'd like an oil filter for my PC, please."

(050171-1)

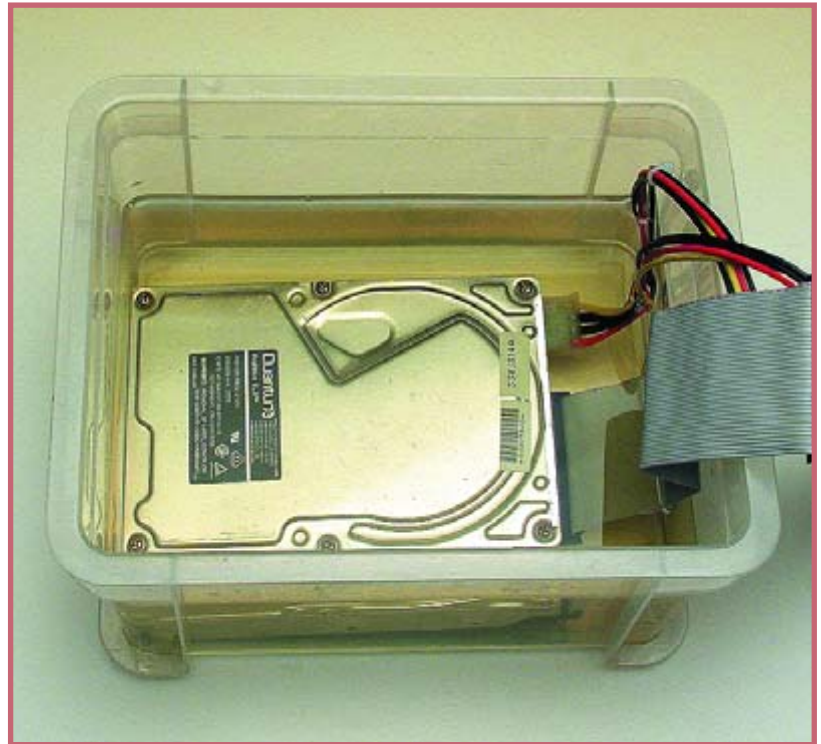

Internet sites

- [1] www.markusleonhardt.de/oelrechner.html
- [2] www.pctechguide.com/04disks_SMART.htm
- [3] www.markusleonhardt.de/forum/

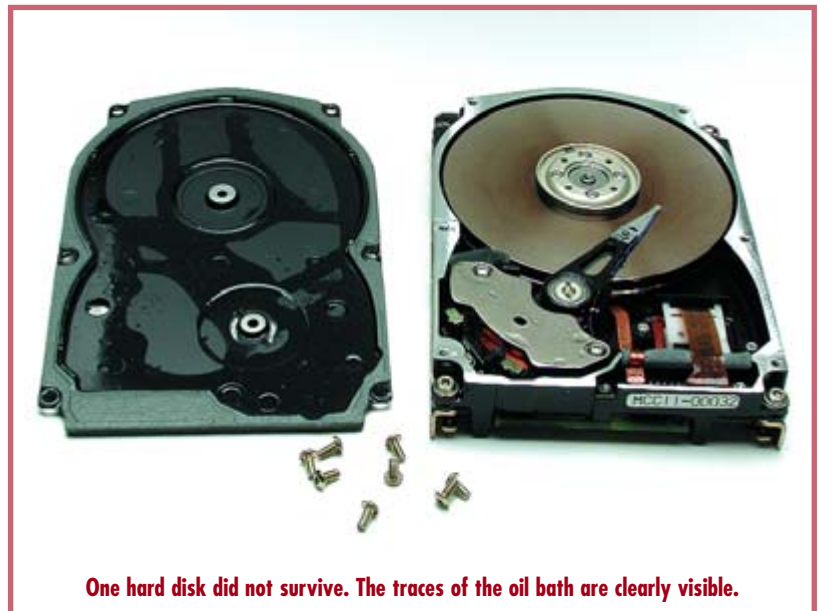

One hard disk did not survive. The traces of the oil bath are clearly visible.

Cascode stage or “collector follower”

Jean-Paul Brodier

All microprocessors from the 8051 family have inputs and outputs that are ‘quasi-bidirectional’. This means that when power is first applied, the ports behave as inputs with a logic high level and a weak pull-up.

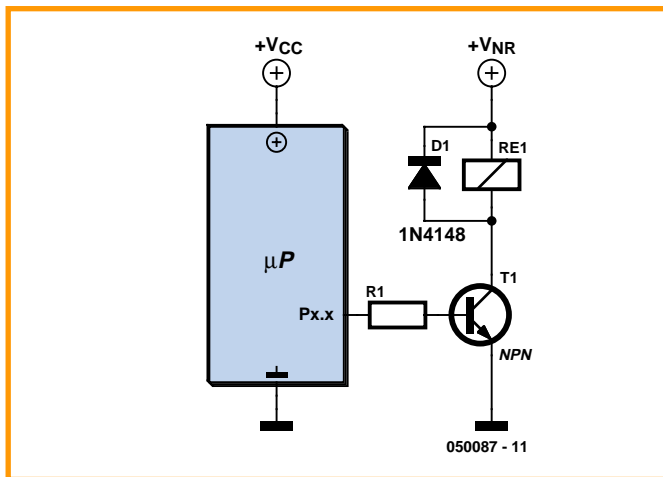

Figure 1. An NPN transistor drives a load.

Glitch

When driving a relay or some other load such as an optocoupler or LED, there is a problem

at power on: the NPN transistor in the common emitter connection (Figure 1) causes an undesirable excitation of the load

from the moment power is applied until the microprocessor has had the chance to turn the output low. In addition, logic high outputs are seldom able to deliver enough current to drive the transistor into saturation because they have been designed to be active low.

To solve both of these problems in one hit, we have to make the active level logic low. This can be done in three different ways: use an emitter follower as a buffer stage (Figure 2a), an inverter in a common emitter circuit (Figure 2b) or an inverter/open collector circuit (Figure 2c). The disadvantage of solution 2a is the fact that the voltage to the load is reduced. In the case of a relay with a 5-V coil there is the risk that the resulting voltage is too low. The disadvantage of

examples 2b and 2c is that they require more parts.

Collector follower

That leaves the open collector buffer in the form of an IC type 7404. This solution, however, also has a few disadvantages. You do not always need all of the 6 buffers in one IC. Also, the SMD version can only handle 12 V. This is too low and dangerous if we happen to supply the load from an unregulated voltage.

The solution presented here combines in one transistor the advantages of the emitter follower (inactive when power is first applied) and open collector (higher power supply voltage, lower current). This circuit has been known since the valve era by the name cascode (drive via the cathode). The goal was to reduce the Miller-effect of the internal (parasitic) capacitances. Not having the option of reducing the capacitance between the internal electrodes, a lower voltage was used instead. The cascode circuit is often used in powerful transmitters (tens of kW) to minimise the Miller-effect. This circuit was also used to limit transistor conduction and to keep the dissipation within bounds, which increased the life of bipolar transistors. This was in the IGBT and VMOS era.

The transistor conducts only when the output from the microprocessor is low (refer Figure 3). The base current is limited by resistor R. This current is determined by the current flowing through the load. When the

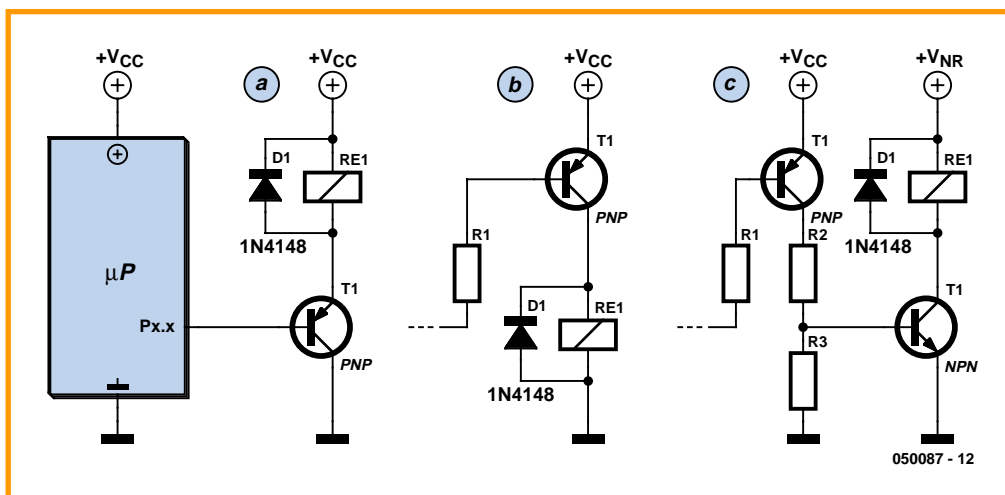

Figure 2. Power stages without unwanted behaviour at power on. a) Emitter follower. b) Inverter stage with common emitter. c) Inverter and open collector.

power is switched on, both the base and emitter see the same potential, V_{CC} , so the transistor remains blocked. One thing we have to keep in mind: we may not exceed the current rating of the microprocessor output because it has to cope with all the current flowing in the emitter of the transistor.

In the case of the quite common 80C51, this maximum current is typically 3.2 mA (two LS TTL loads). This is sufficient to drive an LED without overloading the 5-V regulator, or for driving a PNP power stage at the *high side* (Figure 3b).

The parallel Philips PCF88574 I²C interfaces can handle 25 mA. For the Atmel AT89Cx051 as well as for the Philips P89LPC9xx the limit is 20 mA. For the latter type the cascode circuit or 'collector follower' is even more interesting when the outputs are configured as open-drain because the nominal voltage is only 3.6 V. In all cases we have to make sure that the maximum dissipation of the

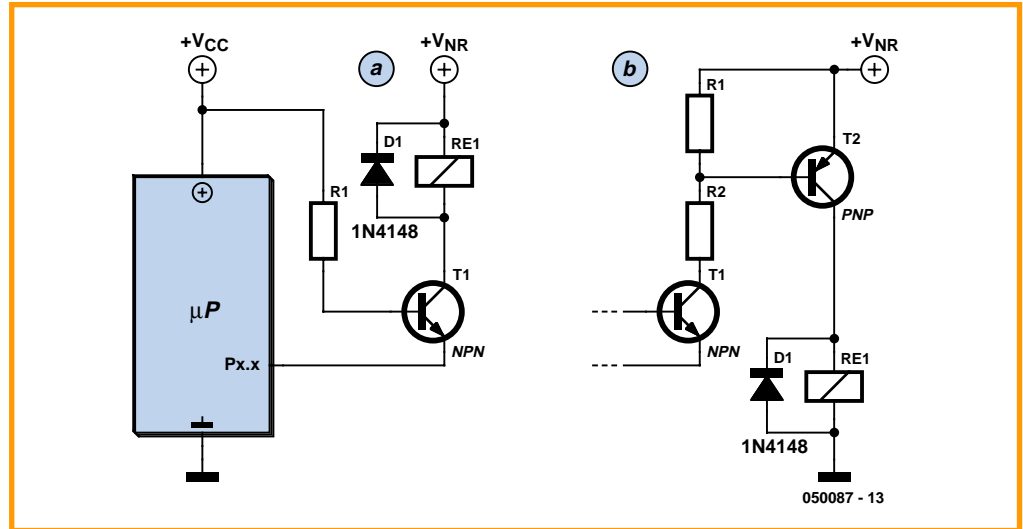

Figure 3. Cascode driver stage with discrete transistor.

package is not exceeded. Should this be the case, then the number of open collectors required will probably justify resorting to a 7404. A current of around 20 mA at

24 V is sufficient to energise a half Watt relay coil, which in turn can drive a load of 16 A at 230 V. For loads driven from the positive side, the voltage and current lim-

its are determined by the power PNP (or VMOS) transistor. The cascode transistor can be a 'digital' type with integrated base and emitter resistors.

(050087-1)

Pot as interrupt generator

Eric Vanderseypen

In battery-powered, microcontroller driven circuits, as well as with microcontrollers operating in cars, it is desirable to switch the micro into power-down mode once a task has been completed. An interrupt request is then required to wake up the micro. This circuit allows an interrupt to be generated in a simple way using a common potentiometer. In the example circuit, the pot may also copy its spindle position to the ADC. This enables the pot to be used for continuously variable settings (like volume) as well for getting the micro out of its power-down mode.

IC1A is configured as a differentiator with R3 preventing oscillation by keeping the gain down to 10 times. Because the opamp operates off a single-rail supply voltage, an 18k/10k potential divider (R1/R2) is able to create a virtual ground level at +1.75 V. This can be done because the LM358 can handle input levels of up to 3.5 V when supplied at 5.0 volts. IC1A supplies a brief High pulse

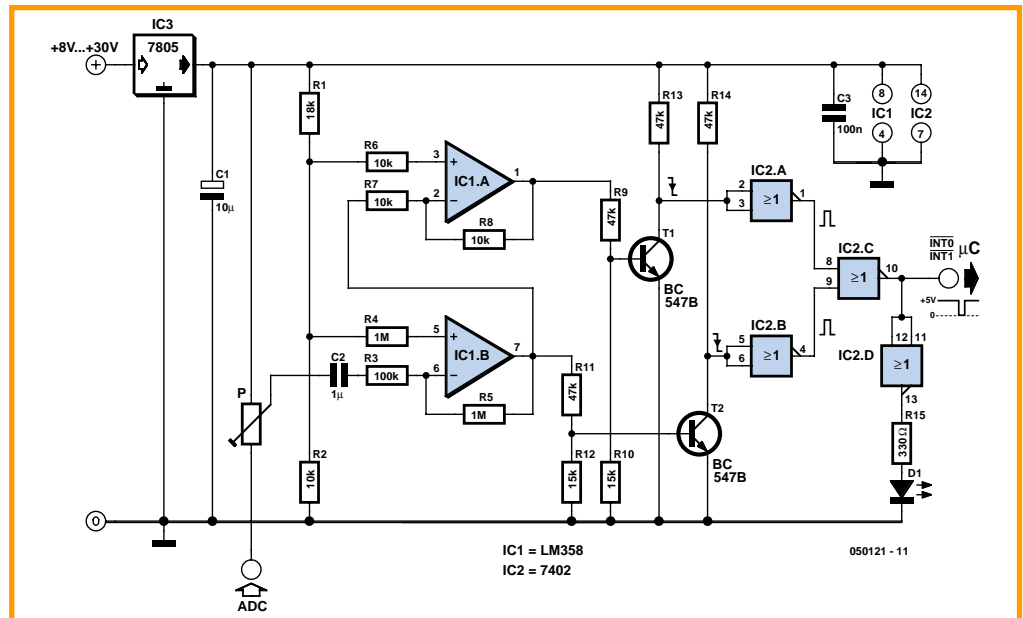

at a falling input voltage, and a similar Low pulse when the input voltage rises. In order to get a High pulse when the potentiometer spindle is turned cw or ccw, IC1B is set up as an inverter. Next, each opamp output drives the base of a BC547 transistor.

The 5 V-to-0 V transitions at both collector outputs are shaped and combined into a usable interrupt pulse by three NOR gates IC2A, IC2B and IC2C. If the potentiometer spindle is turned very slowly, it is possible that the circuit does not respond.

That is why an LED has been added that lights briefly when a pulse is generated. Finally, a tip: a 100-pF capacitor may be connected in parallel with R5 for additional suppression of self-oscillation.

(050121-1)

Visit our website
www.distel.co.uk

THE ORIGINAL SURPLUS WONDERLAND!

THIS MONTH'S SELECTION FROM OUR VAST EVER CHANGING STOCKS

Surplus always
wanted for cash!

GIANT 10" 7 SEGMENT DISPLAYS

A bulk purchase enables us to bring you these GIANT 7 segment digital displays at a now affordable price! The 10" character size gives exceptional readability at long distances and enables a host of applications including score boards, digital clocks, counters, event timers etc. As the units are a simple electro-mechanical device and operate from 12 V DC, simple switching via switches, relays, PIC or PC may be used to control single or multiple digits. Units feature integral 'Zero Power' memory which greatly simplifies design. For an excellent DIY practical article, see the May issue of 'Everyday & Practical Electronics' magazine, Ideal School / College construction project. Supplied in good RFE condition, complete with data sheet.

Less than 30% Only £29.95(B) or 4 / £99.00(D)
of makers price! Order RW44 Order PH26



THE AMAZING TELEBOX



Converts your colour monitor into a QUALITY COLOUR TV!!
The TELEBOX is an attractive fully cased mains powered unit, containing all electronics ready to plug into a host of video monitors or AV equipment which are fitted with a composite video or SCART input. The composite video output will also plug directly into most video recorders, allowing reception of TV channels not normally receivable on most television receivers (TELEBOX M3). Push button controls on the front panel allow reception of 8 fully accessible off air UHF colour television channels. TELEBOX M3 covers virtually all television frequencies VHF and UHF including the HYPERBAND as used by most cable TV operators. Ideal for desktop computer video systems & PIP (picture in picture) setups. For complete compatibility - even for monitors without sound - an integral 4 watt audio amplifier and low level Hi Fi audio output are provided as standard. Brand new - fully guaranteed.

TV SOUND &
VIDEO TUNER
CABLE COMPATIBLE*

TELEBOX ST for composite video input type monitors £36.95
TELEBOX STL as ST but fitted with integral speaker £39.50
TELEBOX MB Multiband VHF/UHF/Cable/Hyperband tuner £89.95
For overseas PAL versions state 5.5 or 6 mHz sound specification.
*For cable / hyperband signal reception Telebox M3 should be connected to a cable type service. Shipping on all Teleboxes, code (B)

NEW State of the art PAL (UK spec) UHF TV tuner module with composite 1V pp video & NICAM Hi fi stereo sound outputs. Micro electronics all on one small PCB only 73 x 160 x 52 mm enable full tuning control via a simple 3 wire link to an IBM pc type computer. Supplied complete with simple working program and documentation. Requires +12V & +5V DC to operate. BRAND NEW - Order as MY00. Only £39.95 code (B)
See www.distel.co.uk/data_my00.htm for picture & full details

HARD DISK DRIVES 2 1/2" - 14"

2 1/2" TOSHIBA MK1002MAV 1.1Gb laptop (12.5 mm H) New £59.95
2 1/2" TOSHIBA MK4313MAT 4.3Gb laptop (8.2 mm H) New £105.00
2 1/2" TOSHIBA MK6409MAV 6.1Gb laptop (12.7 mm H) New £99.00
2 1/2" TOSHIBA MK1814GAV 18 Gb laptop (12 mm H) New £149.95
2 1/2" to 3 1/2" conversion kit for PCs, complete with connectors £15.95
3 1/2" COMPAQ 313706-B21 (IBM) 9 gb ULT/SCSI New £199.00
3 1/2" FUJI FK-309-26 20mb MFM I/F RFE £59.95
3 1/2" CONNER CP3024 20 mb IDE I/F (or equiv.) RFE £59.95
3 1/2" CONNER CP3044 40 mb IDE I/F (or equiv.) RFE £69.00
3 1/2" QUANTUM 40S Prodrive 42mb SCSI I/F, New RFE £49.00
5 1/4" MINISCRIBE 3425 20mb MFM I/F (or equiv.) RFE £49.95
5 1/4" SEAGATE ST-238R 30 mb RLL I/F Refurb £69.95
5 1/4" CDC 9420S-81 40mb H/M MFM I/F RFE tested £99.00
5 1/4" HP 97548 850 Mb SCSI RFE tested £99.00
5 1/4" HP C3010 2 Gbyte SCSI differential RFE tested £195.00
8" NEC D2246 85 Mb SMD interface. New £99.00
8" FUJITSU M2322K 160Mb SMD I/F RFE tested £195.00
8" FUJITSU M2392K 2 Gb SMD I/F RFE tested £345.00
Many other floppy & H drives, IDE, SCSI, ESDI etc from stock, see website for full stock list. Shipping on all drives is code (C)

IC's - TRANSISTORS - DIODES

OBSOLETE - SHORT SUPPLY - BULK
10,000,000 items EX STOCK
For MAJOR SAVINGS
CALL or see web site www.distel.co.uk

COMPUTER MONITOR SPECIALS

Legacy products
High spec genuine multisync.
CGA, EGA, VGA, SVGA

Mitsubishi FA341SETKL 14" SVGA Multisync colour monitor with fine 0.28 dot pitch tube and resolution of 1024 x 768. A variety of inputs allows connection to a host of computers including IBM PC's in CGA, EGA, VGA & SVGA modes. BBC, COMMODORE (including Amiga 1200), ARCHIMEDES and APPLE. Many features: Etched faceplate, test switching and LOW RADIATION MPR specification. Fully guaranteed, in EXCELLENT little used condition. Tilt & Swivel Base £475

VGA cable for IBM PC included. Only £129 (E) Order as CG73
External cables for other types of computers available - CALL

Generic LOW COST SVGA Monitors
We choose the make, which includes Compaq, Mitsubishi, IBM, etc. Supplied ready to run with all cables. Standard RTB 90 day guarantee.

14" £59.00 order TD84	15" £69.00 order TG21	17" £79.00 order TJ66
-----------------------------	-----------------------------	-----------------------------

Supplied in good used condition. Shipping code (D)

VIDEO MONITORS

PHILIPS HCS35 (same style as CM8833) attractively styled 14" colour monitor with both RGB and standard composite 15.625 KHz video inputs via SCART socket and separate phono jacks. Integral audio power amp and speaker for all audio visual uses. Will connect direct to Amiga and Atari BBC computers. Ideal for all video monitoring / security applications with direct connection to most colour cameras. High quality with many features such as front concealed flip controls, VCR correction button etc. Good used condition - fully tested - guaranteed
Dimensions: W14" x H12 1/4" x 15 1/2" D. Only £99.00 (D)

PHILIPS HCS31 Ultra compact 9" colour video monitor with standard composite 15.625 KHz video input via SCART socket. Ideal for all monitoring / security applications. High quality, ex-equipment fully tested & guaranteed (possible minor screen burns). In attractive square black plastic case measuring W10" x H10" x 13 1/2" D. 240 V AC mains powered. Only £79.00 (D)

INDUSTRIAL COMPUTERS

Tiny shoebox sized industrial 40 MHz 386 PC system measuring only (mm) 266 w X 88 h X 272 d. Ideal for dedicated control applications running DOS, Linux or even Windows / Steel case contains 95 to 265 V AC 50 / 60 Hz 70 Watt PSU, a 3 slot ISA passive backplane and a Rocky 318 (PC104) standard, single board computer with 8 MByte NON VOLATILE solid state 'Disk On Chip' RAMDISK. System comprises: Rocky 318 (PC104) SBC ISA card with 40MHz ALI 386SX CPU, 72 pin SIMM slot with 16 MByte SIMM, AMI BIOS, battery backed up real time clock, 2 x 9 pin D 16550 serial ports, EPP/IECP printer port, mini DIN keyboard connector, floppy port, IDE port for hard drives up to 528 MByte capacity, watchdog timer and PC/104 bus socket. The 8 MByte solid state 'disk on a chip' has its own BIOS, and can be formatted, formatted & booted. Supplied BRAND NEW fully tested and guaranteed. For full data see featured item on website. Order as QG36
100's of applications inc: firewall, routers, robotics etc. Only £99.00 (D)

19" RACK CABINETS

Europe's Largest Stocks of
quality rack cabinets,
enclosures and accessories.
Over 1000 Racks from stock

This month's special
33 / 42 / 47 U - High Quality
All steel Rack Cabinets

Made by Eurocraft Enclosures Ltd to the highest possible spec, rack features all steel construction with removable side, front and back doors. Front and all back doors are hinged for easy access and all lockable with five secure 5 lever barrel locks. The front door is constructed of double welded steel with a 'designer style' smoked acrylic front panel to enable status indicators to be seen through the panel, yet remain unobtrusive. Internally the rack features fully slotted reinforced vertical fixing members to take the heaviest of 19" rack equipment. The two movable vertical fixing struts (extras available) are pre-punched for standard 'cage nuts'. A main distribution panel internally mounted to the bottom rear, provides 8 x IEC 3 pin Euro socket and 1 x 13 amp 3 pin switched utility socket. Overall ventilation is provided by fully louvered back door and double skinned top section with top and side louvers. The top panel may be removed for fitting of integral fans to the sub plate etc. Other features include: fitted castors and floor levelers, pre-punched utility panel at lower rear for cable / connector access etc. Supplied in excellent, slightly used condition with keys. Colour Royal blue, some grey available - CALL - Can be supplied in many other configurations.



33U Order as BC44 External dimensions mm=1625H x 635D x 603 W, (64" H x 25" D x 23 1/4" W) Only £245	42U Order as DT20 External dimensions mm=2019H x 635D x 603 W, (79.5" H x 25" D x 23 1/4" W) Only £345	47U Order as RV36 External dimensions mm=2235H x 635D x 603 W, (88" H x 25" D x 23 1/4" W) Only £410
---	---	---

Call for shipping quotation

COLOUR CCD CAMERAS

Undoubtedly a miracle of modern technology & our special buying power! A quality product featuring a fully cased COLOUR CCD camera at a give away price! Unit features full autofocus sensing for use in low light & high light applications. A 10 mm fixed focus wide angle lens gives excellent focus and resolution from close up to long range. The composite video output will connect to any composite monitor or TV (via SCART socket) and most video recorders. Unit runs from 12V DC so ideal for security & portable applications where mains power not available. Overall dimensions 66 mm wide x 117 deep x 43 high. Supplied BRAND NEW & fully guaranteed with user data, 100's of applications including Security, Home Video, Web TV, Web Cams etc, etc.
Order as LK33 ONLY £79.00 or 2 for £149.00 (B)



SOFTWARE SPECIALS

NT4 WorkStation, complete with service pack 3 and licence - OEM packaged. ONLY £89.00 (B)
ENCARTA 95 - CDROM. Not the latest - but at this price! £7.95
DOS 5.0 on 3 1/2" disks with concise books c/w QBasic. £14.95
Windows for Workgroups 3.11+ DOS 622 on 3.5" disks £55.00
Windows 95 CDROM Only - No Licence - £19.95
Wordperfect 6 for DOS supplied on 3 1/2" disks with manual £24.95
shipping charges for software is code B

SOLID STATE LASERS

Visible red, 670nm laser diode assembly. Unit runs from 5 V DC at approx 50 mA. Originally made for continuous use in industrial barcode scanners, the laser is mounted in a removable solid aluminium block, which functions as a heatsink and rigid optical mount. Dims of block are 50 x 50 d x 15 mm. Integral features include over temperature shutdown, current control, laser OK output, and gated TTL ON / OFF. Many uses for experimental optics, comms & lightshows etc. Supplied complete with data sheet.
Order as TD91 ONLY £24.95 (A)

DC POWER SUPPLIES

Virtually every type of power supply you can imagine. Over 10,000 Power Supplies
Ex Stock - Call or see our web site.

RELAYS - 200,000 FROM STOCK

Save EEE's by choosing your next relay from our Massive Stocks covering types such as Military, Octal, Cradle, Hermetically Sealed, Continental, Contactors, Time Delay, Reed, Mercury Wetted, Solid State, Printed Circuit Mounting etc. CALL or see our web site www.distel.co.uk for more information. Many obsolete types from stock. Save EEE's

TEST EQUIPMENT & SPECIAL INTEREST ITEMS

MITSUBUSHI FA3445ETKL 14" Ind. spec SVGA monitors £245
FARNELL 0-60V DC @ 50 Amps, bench Power Supplies £995
FARNELL AP3080 0-30V DC @ 80 Amps, bench Supply £1850
KINGSBILL CZ4031 0-50V @ DC 200 Amps - NEW £3050
1kW to 400 kW - 400 Hz 3 phase power sources - ex stock £1760
IBM 8230 Type 1, Token ring base unit driver £2500
Wayne Kerr RA200 Audio frequency response analyser £49
INFODEC 1U, 24 port, RJ45 network patchpanels. #TH93 £49
3COM 16670 12 Port Ethernet hub - RJ45 connectors #LD97 £89
3COM 16671 24 Port Ethernet hub - RJ45 connectors £89
3COM 16700 8 Port Ethernet hub - RJ45 connectors NEW £39
IBM 53F5991 Token Ring IGS 20 port lobe modules EPOA £45
IBM MAU Token ring distribution panel 8229-23-50/50 £250
AIM 501 Low distortion Oscillator 9Hz to 330KHz, IEEE I/O £250
ALLCON 8960 11605-1880 Mhz hybrid power combiners £250
Trend USA 274 Data Analyser with G703(2M) 64 i/o EPOA £750
Marconi 6310 Programmable 2 to 22 GHz sweep generator £4500
Marconi 2022C 10KHz-1GHz RF signal generator £1550
HP1650B Logic Analyser £3750
HP3781A Pattern generator & HP3782A Error Detector EPOA £990
HP6621A Dual Programmable GPIB PSU 0-7 V 160 watts £1800
HP6264 Rack mount variable 0-20V @ 20A metered PSU £475
HP54121A DC to 22 GHz four channel test set EPOA £7900
HP8130A opt 020 300 Mhz pulse generator, GPIB etc £750
HP A1, A0 8 pen HPGL high speed drum plotters - from HP DRAFTMASTER 1 8 pen high speed plotter £1800
EG-G Brookdale 95035C Precision lock in amp EPOA £4500
Keithley 590 CV capacitor / voltage analyser £3750
Racal ICR40 dual 40 channel video recorder system £4500
Fiskers 45KVA 3 ph On Line UPS - New batteries £12499
Emerson AP130 2.5KVA industrial spec UPS £1499
Mann Tally MT645 High speed line printer £945
Intel SBC 486/133SE Multibus 486 system, 8Mb Ram

Unless marked NEW, items in this section are pre owned.

HP6030A 0-200V DC @ 17 Amps bench power supply £1950
Intel SBC 486/133SE Enhanced Multibus (MSA) New £1150
Nikon HFX-11 (Ephiphot) exposure control unit £1450
PHILIPS PMS518 Pro. TV signal generator £1250
Motoola VME Ss Boards & Components List. SAE / CALL EPOA £550
Trilo C-18 vdc linear, metered 3C amp bench PSU. New £1950
Fujitsu M3041R 600 LPM high speed bench printer £1250
Fujitsu M3041D 600 LPM printer with network interface £2950
Siemens X4400 64Kb to 140Mb demux analyser £500
Perkin Elmer 299B infrared spectrophotometer £3500
Perkin Elmer 597 infrared spectrophotometer £3250
VG Electronics 1035 TELETEXT Decoding Margin Meter £2495
LightBand 60 output high spec 2u rack mount video VDA's £1995
Sekonic SD 1509 18 channel digital Hybrid chart recorder £2500
B&K 2633 Microphone pre amp £750
Taylor Hobson Talysurf amplifier / recorder £1450
ADC SS200 Carbon dioxide gas detector / monitor £75
BBC AM203 PPM Meter (Ernest Turner) + drive electronics £650
ANRITSU 9654A Optical DC-2.5Gb waveform monitor £5650
ANRITSU ML93A optical power meter £990
ANRITSU Fibre optic characteristic test set EPOA £650
R&S FTDZ Dual sound unit £775
R&S SBUF-E1 Vision modulator £5750
WILTRON 6630B 12.4 / 20GHz RF sweep generator £1250
TEK 2445 150 MHz 4 trace oscilloscope £1955
TEK 2465 300 Mhz 300 Mhz oscilloscope rack mount £2900
TEK TDS380 400MHz digital realtime + disk drive, FFT etc £5100
TEK TDS524A 500MHz digital realtime + colour display etc £3950
HP3585A Opt 907 20Hz to 40 Mhz spectrum analyser EPOA £325
PHILIPS PW1730/10 60KX XRAY generator & accessories £2900
VARIACS - Large range from stock - call or see our website
CLAUDE LYONS 12A 240V single phase auto. volt. regs £325
CLAUDE LYONS 100A 240/415V 3 phase auto. volt. regs £2900



ALL MAIL TO
Dept EK, 29 / 35 Osborne Rd
Thornton Heath
Surrey CR7 8PD, UK
Open Mon - Fri 9.00 - 5:30

18 Million Items On Line Now!
Secure Ordering, Pictures, Information
www.distel.co.uk
email = admin@distel.co.uk

ALL ENQUIRIES
0208 653 3333
FAX 0208 653 8888

All prices for UK Mainland. UK customers add 17.5% VAT to TOTAL order amount. Minimum order £10. Bona Fide account orders accepted from Government, Schools, Universities and Local Authorities - minimum account order £100. Cheques over £100 are subject to 7 working days clearance. Carriage charges (A)=£3.50, (B)=£6.50, (C)=£10, (D)=£15.00, (E)=£18.00, (F)=CALL. Allow approx 3 days for shipping - better CALL. All goods supplied to our Standard Conditions of Sale which can be viewed at our website and unless stated guaranteed for 90 days. All guarantees on a return to base basis. All rights reserved to change prices / specifications without prior notice. Orders subject to stock. Discounts for volume. Top CASH prices paid for surplus goods. All trademarks, tradenames etc acknowledged. © Display Electronics 2002. E & O.E..

Elektor Time standard (1988)



ing for the Time Standard was freely distributed to interested readers (on paper, in an envelope, by snail mail!), only very advanced readers were able to compile the program into tokenised code and burn it into an EPROM. Most other readers had to rely on a ready-programmed 27C64 supplied through our Readers Services. Apart from displaying time and date at atomic accuracy, the Time Standard was also capable of outputting time/date information

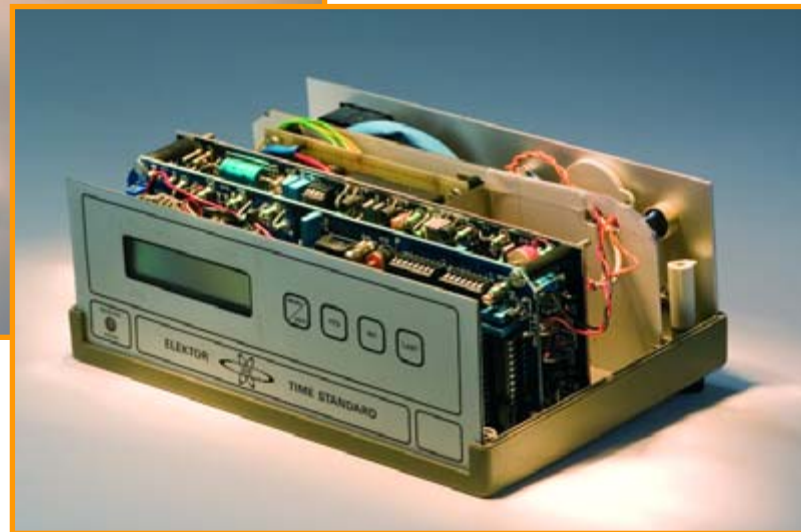

Jan Buiting

The Elektor Time Standard and associated Slave Unit were spin-offs of another hugely successful project, the DCF77 Receiver / Locked Frequency Standard. The receiver was published in the January 1988 issue, the Time Standard and Slave display in the next two issues. All units were housed in then very fashionable and (expensive!) Verobox two-part ABS enclosures which had also been used for a number of Elektor test instrument designs published between 1984 and 1987.

The Time Standard box was designed to process seconds pulses received from the VLF (77.5 kHz) DCF77 time standard transmitter in Mainflingen, Germany, and display time (with atomic accuracy) and date on an LC display. The circuit was based on then extremely popular 8052AH-BASIC microcontroller from Intel, a device, we can safely claim, that made it to fame & glory thanks to *Elektor Electron-*

ics. The 40-way DIL chip contained a BASIC interpreter capable of executing 'tokenised' code from an external EPROM. This, we were told by our resident designer Peter Theunissen, made writing the DCF77 time signal decoding routines 'a doddle' using his specially adapted BASIC computer and interpreter. For example, when concerns were raised (by myself) that not all of Europe was in the time zone served by DCF77 (i.e., CET or GMT+1h), a menu option was quickly added to allow users to select between UTC and GMT+1h. As a relative novelty, a ready-made self-adhesive front panel foil with built-in membrane keys was designed into the project. This expensive item had been produced specially for Elektor. However, when the article went into print (using a rather glum page layout and black & white print), there were yet other concerns regarding the range of the DCF77 transmitter. This is officially claimed as "approximately 1,000 km by groundwave propa-

gation". A quick use of a compass and a map of Europe suggested that the signal would only cover the south-eastern part of the UK, possibly including Greater London. For a couple of months we waited with baited breath for readers' responses, only to receive two enthusiastic reception reports, one from the East coast of Ireland and another from Riyadh, Saudi Arabia! The latter report came from a reader working at a chemical laboratory. I remember he wrote that DCF77 could be received for a few minutes a day only, synchronising the clock, usually around nightfall despite heavy 'static'. A huge wire antenna was used (nothing like the 1-inch ferrite rods we used in our lab, which is less than 100 km away from Mainflingen). Although the BASIC program list-

in the form of ASCII character strings for other (intelligent) equipment to use, for example, a timer or switching clock. Although sales figures of the PCB and EPROM were in the hundreds, I never heard from anyone actually having enjoyed the wonders of the ASCII output so extensively described in the article. The Slave unit published in March 1988 was connected to the Time Standard via screened (microphone) cable, the idea being that one or more Slave units could be installed on walls in rooms at some distance from the main clock unit. Central timekeeping *deluxe* for offices, labs, schools and workshops, but at what an expense and design effort! Not too many PCBs were sold for this extension of the Time Standard.

(055062-1)

QUIZZ'AWAY



Martin Ohsmann is a Professor of Electrical Engineering and Information Technology at FH Aachen and a long-time contributor to *Elektor Electronics*. Through Quizz'away he aims at stimulating thought, speculation, construction and simulation as well as raise interesting questions.

Vanishing voltage

This month we invite you all to look at the operational amplifier circuit depicted in **Figure 1**. A voltage source supplies an input voltage U_i , which is amplified by a factor $R2/R1 = 10$ by opamp OP1a. Opamp OP2b amplifies the (vanishing?) input voltage U_m from OP1a. Capacitors C1 and C2 each have a value that nullifies their effect. A dual opamp type TL082, NE5532, MC1458 or similar is used. The

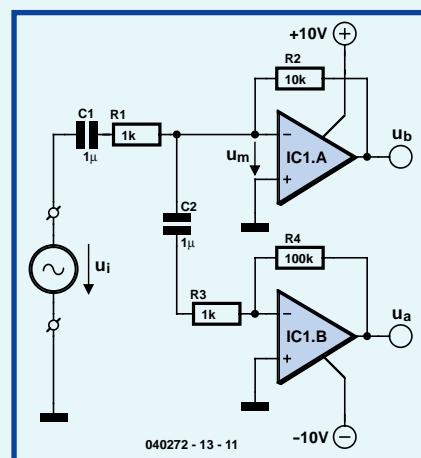

Figure 1. Opamp circuit.

Solution to the July/August

(p. 134; 'AF signal finds an impossible path')

A close look at the internal circuit of the TL431 IC as shown in **Figure 3**

reveals that the chip actually behaves like an npn transistor with a base-emitter voltage of 2.5 volts and very high gain (open-loop gain of the opamp multiplied by the steepness of the transistor). The 'base current' of this device is negligible.

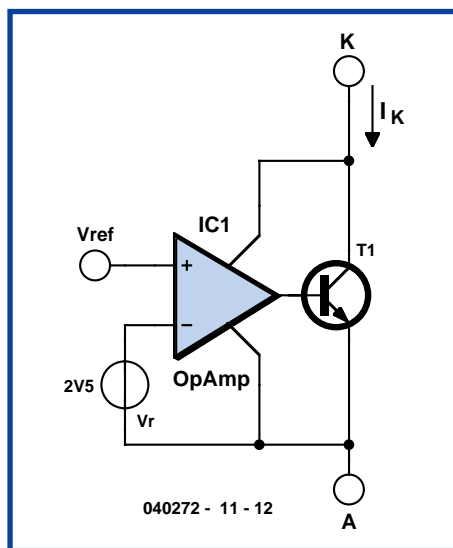

Figure 3. Internal diagram of the TL431.

Armed with this knowledge we can redraw

the circuit diagram of the amplifier as shown in **Figure 4**. Transistor T2 now replaces IC1, while decoupling capacitor C1 (between point A and ground) has been omitted for the moment.

Those of you familiar with two-transis-

tor circuits will recognise the configuration as a classic cascade circuit. Transistor T2 (or IC1 for that matter) sees a constant base voltage fixed by poten-

tial divider R4/R5. Consequently the voltage at the emitter of T2, i.e., point A, is also constant. Using the TL431 as a 'transistor' the voltage at point A is held extremely constant. However, when the voltage at point A does not change, consequently it makes no difference if a capacitor is connected between A and ground. After

all, the capacitor charge is not reversed in operation. Transistor T1 works in the usual way, albeit with a constant collector-emitter voltage. For small-signal behaviour, its collector current is proportional with the input voltage and the resulting collector current is

Please send your answer to this month's Quizz'away problem, by email, fax or letter to:
Quizz'away, Elektor Electronics,
PO Box 190,
Tunbridge Wells TN5 7WY,
England.
Fax (+44) (0)1580 200616.
Email:
editor@elektor-electronics.co.uk,
subject: 'quizzaway 10-05'.

The closing date is
31 October 2005

(solution published in the December 2005 issue). The outcome of the quiz is final. The quiz is not open to employees of Segment b.v., its business partners and/or associated publishing houses.

ELEKTOR SHOWCASE

To book your showcase space contact Huson International Media

Tel. 0044 (0) 1932 564999 Fax 0044 (0) 1932 564998

ALLGOOD TECHNOLOGY

www.allgoodtechnology.com

Low-medium volume sub-contract assembly. SMT specialist since 1990. Customers include military, aerospace etc. 0402 to BGA capabilities, automatic assembly and hand built prototypes.

AUDIOXPRESS

www.audioXpress.com

The premier do-it-yourself audio magazine for 35 years.

- Hands-on projects
- Helpful articles
- Expert advice
- New technologies

Full range of books, back issues on CD



BETA LAYOUT

www.pcb-pool.com

Beta layout Ltd Award-winning site in both English and German offers prototype PCBs at a fraction of the cost of the usual manufacturer's prices.



BURN TECHNOLOGY LTD

<http://www.burntec.com>

Test & Measurement Equipment Distributors

- Anemometers
- Clamp Meters
- Light Meters
- LCR Meters
- Sound Meters
- Multimeters
- Device Programmers

Burn Technology Limited, Winfrith Technology Centre, Dorchester, Dorset, DT2 8DH
Tel: (01305) 852090 Fax: (01929) 463214



COMPUCUT

<http://www.compucutters.com>

Computer Numerical Control from your home PC. Great for tricky jobs, and accurate repetitive work. We supply: - Software - Interface - Manual - Support
Price £250 plus postage.

CONFORD ELECTRONICS

<http://www.confordelec.co.uk>

Lightweight portable battery/mains audio units offering the highest technical performance. Microphone, Phantom Power and Headphone Amplifiers. Balanced/unbalanced signal lines with extensive RFI protection.

DANBURY ELECTRONICS

<http://www.livinginthepast.demon.co.uk>

Here you will find our mains and output transformers in Mike Holme's range of valve/tube amplifiers (PP & SE). Also circuits, parts lists, chassis, advice.

EASYSYNC

<http://www.easysync.co.uk>

EasySync Ltd sells a wide range of single and multi-port USB to RS232/RS422 and RS485 converters at competitive prices.



ELNEC

www.elnec.com

- device programmer manufacturer
- selling through contracted distributors all over the world
- universal and dedicated device programmers
- excellent support and after sale support
- free SW updates
- reliable HW
- once a months new SW release
- three years warranty for most programmers



FUTURLEC

<http://www.futurlec.com>

Save up to 60% on

- Electronic Components
- Microcontrollers, PIC, Atmel
- Development Boards, Programmers

Huge range of products available on-line for immediate delivery, at very competitive prices.



FUTURE TECHNOLOGY DEVICES

<http://www.ftdichip.com>

FTDI designs and sells USB-UART and USB-FIFO interface i.c.'s.

Complete with PC drivers, these devices simplify the task of designing or upgrading peripherals to USB



ILP ELECTRONICS LIMITED

<http://www.ilpelectronics.com>

ILP has been in the audio industry for over 30 years primarily manufacturing both standard and custom audio modules and pre-amplifiers.



IPEVA LIMITED

<http://www.ipeva.com>

IPEVA sell low cost USB FPGA development boards. IPEVA provide Design Consultancy for Embedded Systems, OpenCores-IP, FPGA, ASIC, HDL translation and migration. Tel. 0870 080 2340.



JLB ELECTRONICS

www.jlbelectronics.com

Suppliers of electrical / electronic parts and consumables. Including:

- Cable ties / bases
- Tools / hardware
- Bootlace ferrules
- Connectors
- Solvent sprays & cleaners
- PVC Tape
- Heat Sink compound

LONDON ELECTRONICS COLLEGE

<http://www.lec.org.uk>

Vocational training and education for national qualifications in Electronics Engineering and Information Technology (BTEC First National, Higher National NVQs, GCSEs and Advanced Qualifications). Also Technical Management and Languages.

MQP ELECTRONICS

<http://www.mqpelectronics.co.uk>

Leaders in Device Programming Solutions.

- Online shop
- Low Cost Adapters for all Programmers
- Single Site and Gang Programmers
- Support for virtually any Programmable Device



products and services directory

NEW WAVE CONCEPTS

www.new-wave-concepts.com

Software for hobbyists:

- Livewire circuit simulation software, only £34.99
- PCB Wizard circuit design software, only £34.99

Available from all Maplin Electronics stores and www.maplin.co.uk.



PCB WORLD

<http://www.pcbworld.org.uk>

World-class site: Your magazine project or prototype PCB from the artwork of your choice for less. Call Lee on 07946 846159 for details. Prompt service.

PICDOS™

<http://www.picdos.com>

Hard disk, DOS & files on PIC16F877.

SmartMedia™ based. No complex hardware just wires. Run-Debug existing PIC code & interrupts. Free schematics, software, debugger

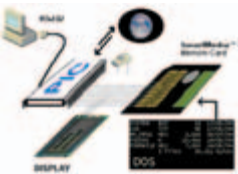

QUASAR ELECTRONICS

www.QuasarElectronics.com

Over 300 electronic kits, projects and ready built units for hobby, education and industrial applications including PIC/ATMEL programming solutions. Online ordering facilities.

Tel: +44 (0) 870 246 1826

Fax: +44 (0) 870 460 1045

Email: sales@QuasarElectronics.com



SYTRONIC TECHNOLOGY LTD

www.m2mtelemetry.com

Supplier of wireless modules and accessories for remote monitoring M2M applications.

- GSM/GPRS TCP/IP modules
- Embedded GSM/GPRS modem
- Development Kits
- GPS modules
- GSM/GPRS antennas
- Adapter cables

Online ordering facilities.

Tel (01394) 210911



ULTRALEDs



<http://www.ultraleds.co.uk>

tel: 0871 7110413

Large range of low cost Ultra bright leds and Led related lighting products. Major credit cards taken online with same day depatch.

ROBOT ELECTRONICS

<http://www.robot-electronics.co.uk>

- Ultrasonic rangefinders
- Motor H-Bridge controllers
- Magnetic Compasses
- RC servos and controllers
- PIC programmers and components
- Electronic Design/Development and Manufacturer to industry



USB INSTRUMENTS

<http://www.usb-instruments.com>

USB Instruments specialises in PC based instrumentation products and software such as Oscilloscopes, Data Loggers, Logic Analysers which interface to your PC via USB.



SHOWCASE YOUR COMPANY HERE

Elektor Electronics has a feature to help customers promote their business, Showcase - a permanent feature of the magazine where you will be able to showcase your products and services.

- For just £220 + VAT (£20 per issue for eleven issues) Elektor will publish your company name, website address and a 30-word description

- For £330 + VAT for the year (£30 per issue for eleven issues) we will publish the above plus run a 3cm deep full colour image - e.g. a product shot, a screen shot from your site, a company logo - your choice

Places are limited and spaces will go on a strictly first come, first served basis. So please fax back your order today!

I wish to promote my company, please book my space:

- Text insertion only for £220 + VAT
- Text and photo for £330 + VAT

NAME:.....ORGANISATION:.....

JOB TITLE:.....

ADDRESS:.....

.....

.....TEL:.....

PLEASE COMPLETE COUPON BELOW AND FAX BACK TO 00-44-(0)1932 564998

COMPANY NAME.....

WEB ADDRESS.....

30-WORD DESCRIPTION.....

.....

.....

.....

.....

VIRTINS TECHNOLOGY

<http://www.virtins.com>

PC based virtual instrument for electronics enthusiasts, students and professionals, including full-fledged sound card real time Oscilloscope, Spectrum, Analyzer and Signal, Generator, Downloader and try.



ELECTRONIC ENTHUSIASTS

Only one magazine tests its projects and circuits in its own lab before publication

**ELEKTOR ELECTRONICS
THE ELECTRONICS &
COMPUTER MAGAZINE**

**SUBSCRIBE
TODAY!**

Contact: Worldwide Subscription Service Ltd,
Unit 4 Gibbs Reed Farm, Pashley Road,
Titchhurst TN5 7HE
Telephone: 01580 200657 Fax: 01580 200616
www.elektor-electronics.co.uk

Order now using the Order Form in the Readers Services section in this issue.

CD-ROM BESTSELLERS

Elektor 2004

This CD-ROM contains all editorial articles, with the exception of New Products items, published in Elektor Electronics magazine Volume 2004. Using the supplied Acrobat Reader program, articles are presented in the same layout as originally found in the magazine. The DiskMirror utility on this CD-ROM allows your earlier Elektor year volume CD-ROMs (1997-2003) to be added to a large archive on hard disk for fast access and easy reference. A built-in search function allows you to find references in any article from the archive on hard disk, or from individual year volume CD-ROMs you have available. **£16.25 (US\$ 28.75)**



Audio Collection 2

A unique CD-ROM for the true audio lover, containing no fewer than 75 audio designs from the past five year volumes of Elektor Electronics magazine. The articles on the CD-ROM cover test & measurement equipment, amplifiers, digital audio and loudspeaker technology. Highlights include the Crescendo Millennium Edition, Audio-DAC 2000, Audio-ADC 2000 and the IR-S/PDIF Transmitter and Receiver. Using the included Acrobat Reader you are able to browse the articles on your computer, as well as print texts, circuit diagrams and PCB layouts. **£12.05 (US\$ 21.25)**



ECD

Elektor's Components Database gives you easy access to design data for over 5,700 ICs, more than 35,000 transistors, FETs, thyristors and triacs, just under 25,000 diodes and 1,800 optocouplers. All databank applications are fully interactive, allowing the user to add, edit and complete component data. **£12.95 (US\$ 22.90)**



More information on www.elektor-electronics.co.uk

PC-Interfaces under Windows

PC Interfaces can be used for more than just the printer, mouse, modem and joystick! While it was relatively easy to directly access PC interfaces using a DOS computer, under Windows things are not all that simple. This book (CD-ROM incl.) shows you how it can be done. The authors describe the DIY construction and programming of a number of highly interesting circuits.

ISBN 0-905705-65-3 • 265 pages • **£25.95**

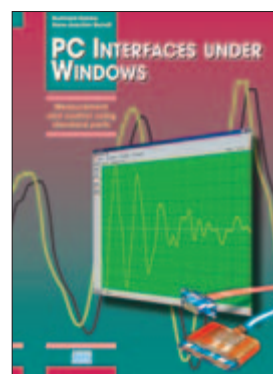

Handbook for sound technicians

This book contains chapters on basic theory; microphones and musical instruments; various types of amplifier; loudspeakers; effects equipment; recording techniques; lighting equipment; the rehearsal room; and faultfinding and small repairs. It also contains a useful glossary of terms used in sound engineering and a list of adjectives describing sound colouring.

ISBN 0-905705-48-3 • 276 pages • **£20.75**



BESTSELLING BOOKS

Top-5

1 308 Circuits

ISBN 0-905705-66-1 **£18.20**

2 PC-Interfaces under Windows

ISBN 0-905705-65-3 **£25.95**

3 Modern High-end Valve Amplifiers

ISBN 0-905705-63-7 **£25.95**

4 Lasers: Theory and Practice

ISBN 0-905705-52-1 **£20.75**

5 Dictionary of Monitor Technology

ISBN 0-905705-64-5 **£25.95**



More information on www.elektor-electronics.co.uk

Due to practical constraints, final illustrations and specifications may differ from published designs. Prices subject to change. See www.elektor-electronics.co.uk for up to date information.

ESR/C Meter

(September 2005)

Kit of parts including PCB, default LCD module, 2x16 characters and programmed controllers.

Enclosure not included.

040259-71

£ 63.99 / \$ 119.95



Matching enclosure

040259-72

£ 6.99 / \$ 12.95

GPS Receiver on USB

(June 2005)

Complete kit (not including IC3) with Lassen iQ-receiver and extra long cable, CD with software and water-proof antenna case.

040264-71

£ 77.65 / \$ 146.25



Kits & Modules

OBD-2 Analyser

(July/August 2005)

Kit of parts including PCB, programmed controller, components (including IC7 ; IC3 = PCA82C250, 12 V), enclosure and RS232 cable.

OBD cable not included.

050092-71

£ 52.50 / \$ 96.95



OBD cable

050092-72

£ 27.55 / \$ 51.95

LPC210x ARMee Development System

(Elektor Electronics April 2005)

- Processor board, ready-built and tested

040444-91

£ 25.50

\$ 48.05

- Motherboard (bare, without components)

040444-2

£ 11.70

\$ 22.05

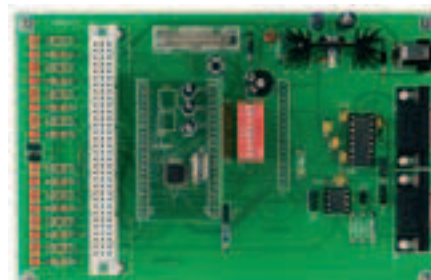

Further products from Elektor Electronics:

READY-BUILT PROJECTS

	£	\$
ClariTy 300-W Class-T Amplifier		
030217-91 Amplifier board with SMDs pre-fitted; cores for L1 & L2	34.50	55.70
Flash Microcontroller Starter Kit		
010208-91 ready-assembled PCB incl. software, cable, adapter & related articles	69.00	112.50
Gameboy Digital Sampling Oscilloscope (GBDSO)		
990082-91 ready-assembled board, incl. the PC software and related articles	103.00	183.00
Micro Webserver with MSC1210 Board		
030060-91 Microprocessor Board, ready-assembled	75.90	142.95
044026-91 Network Extension Board, ready-assembled	44.50	83.95
044026-92 Combined package (030060-91 & 044026-91 & related articles)	117.50	220.95

No. 347 OCTOBER 2005

27C512 Emulator		
030444-11 Disk, project software	5.20	9.75
030444-31 EPM7064SLC84-15, programmed	27.50	51.95
030444-41 AT90S8515-4PC, programmed	15.10	28.35
Colossus Jr.		
040267-11 Disk, PIC source code	5.20	9.75
040267-41 PIC12F675-C/P, programmed	4.10	5.35

Flash Lock for PCs

050107-41 PIC16F628A-I/SO, programmed	5.00	9.45
050107-81 CD-ROM, project software	6.90	12.95

No. 346 SEPTEMBER 2005

ESR/C Meter		
040259-1 PCB, bare	12.40	23.35
040259-11 Disk, PIC source & hex codes	5.20	9.75
040259-41 PIC16F877-20/P, programmed	15.50	29.25
040259-42 PIC16F84A-20/P, programmed	10.30	19.45
040259-71 kit of parts without enclosure	63.99	119.95
040259-72 matching enclosure	6.99	12.95

Hitting the High Note

040015-41 ATmega8-16PC, programmed	15.50	29.25
040015-11 Disk, project software	5.20	9.75

Precision Barometer/Altimeter

040313-11 Disk, project software	5.20	9.75
040313-41 PIC16F876, programmed	16.55	31.15
040313-1 PCB	7.55	14.25

Racetrack Timer

040395-41 AT89C2051-24PI	6.85	12.95
040395-81 CDROM, project software	5.15	9.75

No. 345 JULY/AUGUST 2005

1 MHz Frequency Counter		
030045-11 Disk, project software	5.20	9.75
030045-41 AT90S2313-10PI, programmed	5.50	10.35

Code Lock with One Button

040481-11 Disk, source & hex files	5.20	9.75
040481-41 PIC16F84, programmed	6.85	12.95

Digital VU Meter

050118-11 Disk, Attiny software	5.20	9.75
050118-41 Attiny 15L, programmed	3.40	6.45

DIL/SOIC/TSSOP Adapter Boards

040289-1 PCB, for 20-way DIL IC	6.75	12.70
040289-2 PCB, for 20-way SOIC IC	6.75	12.70
040289-3 PCB, for 20-way TSSOP IC	6.75	12.70

MP3 Adaptor for TV

054035-1 PCB, bare	3.95	7.50
054035-11 Disk, project software	5.20	9.75
054035-31 EPM7064SLC44-10, programmed	27.55	51.95

OBD-2 Analyser

050092-1 PCB, bare	8.95	16.85
050092-41 T89C51CC02UA, programmed	26.20	49.40
050092-71 Kit of parts without cable	52.50	96.95

Products for older projects (if available)
may be found on our website
www.elektor-electronics.co.uk

home construction = fun and added value

Electronics Software

Free CAD software with the November issue.

Software for electronics designers is gaining momentum. Drawing circuit diagrams, simulating them and designing a PCB, it's all done on a PC these days. CAD software that's of interest to the electronics engineer usually covers the complete design cycle from schematics entry right up to circuit board design. The November 2005 issue allows you to delve into the subject. Besides a few articles about E-CAD we also offer you a plethora of software packages



(demos and trial versions but also fully functional software) to experiment with to your heart's content.

Do not miss this special issue!

Theme Plan for 2005	
January	Power Supplies
February	Wireless
March	Sound
April	Microcontrollers
May	Sensors
June	Environment
July/August	Summer Circuits
September	Test & Measurement
October	Security
November	CAD Software
December	Optoelectronics

Modular Design with E-Blocks

A lot is changing in electronics. In the old days, designers were busy wielding a solder iron and discrete components by the cartload. By contrast, today's designs consist mostly of software, the hardware being reduced to a few standard building blocks used in lots of applications. By introducing the E-Blocks modular electronics design system *Elektor Electronics* presents an extensive and affordable series of hardware and software modules with extremely high educational value. Writing E-Blocks software is a breeze thanks to *Flowcode* which also works with modular blocks. Next month we will introduce the system.



RESERVE YOUR COPY NOW!

UK subscribers will receive the magazine a few days before this date.

The November 2005 issue goes on sale on Saturday 22 October 2005 (UK distribution only).

Article titles and magazine contents subject to change.

NEWSAGENTS ORDER FORM

SHOP SAVE / HOME DELIVERY

Please save / deliver one copy of *Elektor Electronics* magazine for me each month

Name:

Address:

Post code:

Telephone:

Date:

Signature:



Please cut out or photocopy this form, complete details and hand to your newsagent. *Elektor Electronics* is published on the third Friday of each month, except in July. Distribution S.O.R. by Seymour (NS).

INDEX OF ADVERTISERS

Allgood Technology, Showcase	www.allgoodtechnology.com	80	Number One Systems	www.numberone.com	37
Audioexpress, Showcase	www.audioexpress.com	80	Nurve Networks	www.xgamestation.com	53
Avit Research	www.avitresearch.co.uk	53	PCB World, Showcase	www.pcbworld.org.uk	81
Beta Layout, Showcase	www.pcb-pool.com	47, 80	Picdos, Showcase	www.picdos.com	81
Bitscope Designs	www.bitscope.com	27	Pico	www.picotech.com	37
Breadboarding Systems	www.breadboarding.co.uk	3	Quasar Electronics, Showcase	www.quasarelectronics.com	71, 81
Burn Technology LTD, Showcase	www.burntec.com	80	RD Research	www.spice-software.com	13
CMS	www.cms.uk.com	47	Robot Electronics, Showcase	www.robot-electronics.co.uk	81
Compucut, Showcase	www.compucutters.com	80	ScanTool	www.obdcables.com	25
Conford Electronics, Showcase	www.confordelec.co.uk	80	Showcase	80, 81	
Cricklewood	www.cricklewoodelectronics.com	53	Sytronic Technology, Showcase	www.m2mtelemetry.com	81
Danbury, Showcase	www.livinginthepast.demon.co.uk	80	Total Telematics	www.total-telematics.com	25
Display Electronics	www.distel.co.uk	76	Ultraleds, Showcase	www.ultraleds.co.uk	81
Easysync, Showcase	www.easysync.co.uk	7, 80	University of Manchester	www.saelig.com	6
Elneec, Showcase	www.elneec.com	80	USB Instruments, Showcase	www.usb-instruments.com	81
Eurocircuits	www.thepcbshop.com	25	Viewcom, Showcase	www.viewcom.f9.co.uk	81
ExpressPCB	www.expresspcb.com	25	Virtins Technology, Showcase	www.virtins.com	81
Fast Components	www.fastcomponents.co.uk	53			
Forest	www.forecd.co.uk	26			
Future Technology Devices, Showcase	www.ftdichip.com	80			
Futurlec, Showcase	www.futurlec.com	80			
ILP Electronics Limited, Showcase	www.ilpelectronics.com	80			
Ipeva Limited, Showcase	www.ipeva.com	80			
Jaycar Electronics	www.jaycarelectronics.co.uk	2			
JLB Electronics, Showcase	www.jlbelectronics.com	80			
Labcenter	www.labcenter.co.uk	88			
Lichfield Electronics	www.lichfieldelectronics.co.uk	47			
London Electronics College, Showcase	www.lec.org.uk	80			
MQP Electronics, Showcase	www.mqpelectronics.co.uk	80			
New Wave Concepts, Showcase	www.new-wave-concepts.com	81			

Advertising space for the issue of 15 November 2005

may be reserved not later than 18 October 2005

with Huson International Media – Cambridge House – Gogmore Lane – Chertsey, Surrey KT16 9AP – England – Telephone 01932 564 999 – Fax 01932 564998 – e-mail: relgar@husonmedia.com to whom all correspondence, copy instructions and artwork should be addressed.

ORDERING INSTRUCTIONS, P&P CHARGES

Except in the USA and Canada, all orders, except for subscriptions (for which see below), must be sent BY POST or FAX to our Tunbridge Wells address using the Order Form overleaf. On-line ordering: <http://www.elektor-electronics.co.uk>

Readers in the USA and Canada may (but are not obliged to) send orders, except for subscriptions (for which see below), to the USA address given on the order form. Please apply to Old Colony Sound for applicable P&P charges. Please allow 4-6 weeks for delivery.

Orders placed on our Tunbridge Wells office must include P&P charges (Priority or Standard) as follows:

UK: £4.00 Europe: £5.00 (Standard) or £7.00 (Priority) Outside Europe: £8.00 (Standard) or £12.00 (Priority)

HOW TO PAY

Unless you have an approved credit account with us, all orders must be accompanied by the full payment, including postage and packing charges as stated above. Payment may be made by cheque **drawn on a London clearing bank** (but see para. 4 below), postal order, VISA, Access, MasterCard or EuroCard (when paying by credit card, the order must go the cardholder's address). Do not send cash through the mail. Cheques and postal orders should be crossed and made payable to 'Elektor Electronics (Publishing)'. Payment may also be made by direct transfer from a private or business Giro account to our **Giro account No. 34-152-3801** by completing and sending to the National Giro Centre, in a National Giro postage paid envelope, a National Giro transfer/deposit form. Do not send Giro transfers direct to us, as this will delay your order. If you live outside the UK, payment may also be made by Bankers' sterling draft **drawn on a London clearing bank**, Eurocheque made out in pounds sterling (with holder's guarantee card number written on the back), or US or Canadian dollar cheque drawn on a US or Canadian bank. If you pay by Bankers' sterling draft, make clear to the issuing bank that your full name and address MUST be communicated to the London clearing bank. Our bankers are **NAT WEST PLC, 1 St James's Square, Wadhurst, East Sussex TN5 6BH, England. Our account number is 3512 5225, Sorting Code 60-22-15. IBAN code: GB40 NWB K6 022 15 3512 5225 BIC code: NWB KGB 2L**

COMPONENTS

Components for projects appearing in Elektor Electronics are usually available from certain advertisers in this magazine. If difficulties in the supply of components are envisaged, a source will normally be advised in the article. Note, however, that the source(s) given is (are) not exclusive.

TERMS OF BUSINESS

Delivery Although every effort will be made to dispatch your order within 2-3 weeks from receipt of your instructions, we can not guarantee this time scale for all orders. **Returns** Faulty goods or goods sent in error may be returned for replacement or refund, but not before obtaining our consent. All goods returned should be packed securely in a padded bag or box, enclosing a covering letter stating the dispatch note number. If the goods are returned because of a mistake on our part, we will refund the return postage. **Damaged goods** Claims for damaged goods must be received at our Tunbridge Wells office within 10-days (UK); 14-days (Europe) or 21-days (all other countries). **Cancelled orders** All cancelled orders will be subject to a 10% handling charge with a minimum charge of £5.00. **Patents** Patent protection may exist in respect of circuits, devices, components, and so on, described in our books and magazines. Elektor Electronics (Publishing) does not accept responsibility or liability for failing to identify such patent or other protection. **Copyright** All drawings, photographs, articles, printed circuit boards, programmed integrated circuits, diskettes and software carriers published in our books and magazines (other than in third-party advertisements) are copyright and may not be reproduced or transmitted in any form or by any means, including photocopying and recording, in whole or in part, without the prior permission of Elektor Electronics (Publishing) in writing. Such written permission must also be obtained before any part of these publications is stored in a retrieval system of any nature. Notwithstanding the above, printed-circuit boards may be produced for private and personal use without prior permission. **Limitation of liability** Elektor Electronics (Publishing) shall not be liable in contract, tort, or otherwise, for any loss or damage suffered by the purchaser whatsoever or howsoever arising out of, or in connexion with, the supply of goods or services by Elektor Electronics (Publishing) other than to supply goods as described or, at the option of Elektor Electronics (Publishing), to refund the purchaser any money paid in respect of the goods. **Law** Any question relating to the supply of goods and services by Elektor Electronics (Publishing) shall be determined in all respects by the laws of England.

January 2005

SUBSCRIPTION RATES FOR ANNUAL SUBSCRIPTION

	Standard	Plus
United Kingdom	£39.50	£46.00
Economy Mail		
Rest of the World (excluding Europe)	£51.30	£57.80
Priority Airmail		
Europe & Eire	£51.30	£57.80
Outside Europe	£65.00	£71.50
Airfreight		
USA & Canada only	US\$88.00	US\$98.00

Payment should be made by:

- Cheque or bankers' draft in sterling drawn on a London clearing bank (except in the USA and Canada — see below);
- US\$ cheques drawn on a US or Canadian bank — only by subscribers in the USA or Canada.
- Direct transfer to our bank (NAT WEST PLC, 1 St James's Square, Wadhurst, East Sussex TN5 6BH, England).
Our account number is 3512 5225, Sorting Code 60-22-15.
IBAN code: GB40 NWB K6 022 15 3512 5225 BIC code: NWB KGB 2L
- Postal order.
- Credit card: VISA, ACCESS, Euro/MasterCard, JCB Electron or Switch.
- Transfer to our Giro Account number 34 152 3801. Giro transfers should be made by completing and sending the appropriate transfer/deposit form to the National Giro Centre (UK) or to your national Giro Centre.

Cheques and postal orders should be made payable to Elektor Electronics (Publishing). Do not send cash through the mail.

SUBSCRIPTION CONDITIONS

The standard subscription order period is twelve months. If a permanent change of address during the subscription period means that copies have to be despatched by a more expensive service, no extra charge will be made. Conversely, no refund will be made, nor expiry date extended, if a change of address allows the use of a cheaper service. Student applications, which qualify for a 20% (twenty per cent) reduction in current rates, must be supported by evidence of studentship signed by the head of the college, school or university faculty. A standard Student Subscription costs £31.60, a Student Subscription-Plus costs £37.60 (UK only).

Please note that new subscriptions take about four weeks from receipt of order to become effective.

Cancelled subscriptions will be subject to a charge of 25% (twenty-five per cent) of the full subscription price or £7.50, whichever is the higher, plus the cost of any issues already dispatched. Subscriptions cannot be cancelled after they have run for six months or more.

January 2005

Straight from the heart of electronics each month

This Issue:
SECURITY



Personal, PC and the home



Next Issue:

ELECTRONICS SOFTWARE

Modular Design with E-Blocks

Want to know everything each month?

Select your own annual subscription and receive
a free 1W Luxeon LED Torchlight



Available options:

- Elektor Electronics annual subscription (standard)
You receive 11 issues, including the July/August double issue.
- Elektor Electronics annual subscription-PLUS
You receive 11 issues, including the July/August double issue,
plus a copy of the Elektor Electronics Volume 2005 CD-ROM
(normal price £16.25). Your saving: approx. £10.00!

elektor
electronics

Please fill out the Order Form with this issue.
Subscription rates and conditions may be found at the back of this issue.

PROTEUS

The Complete Electronics Design System

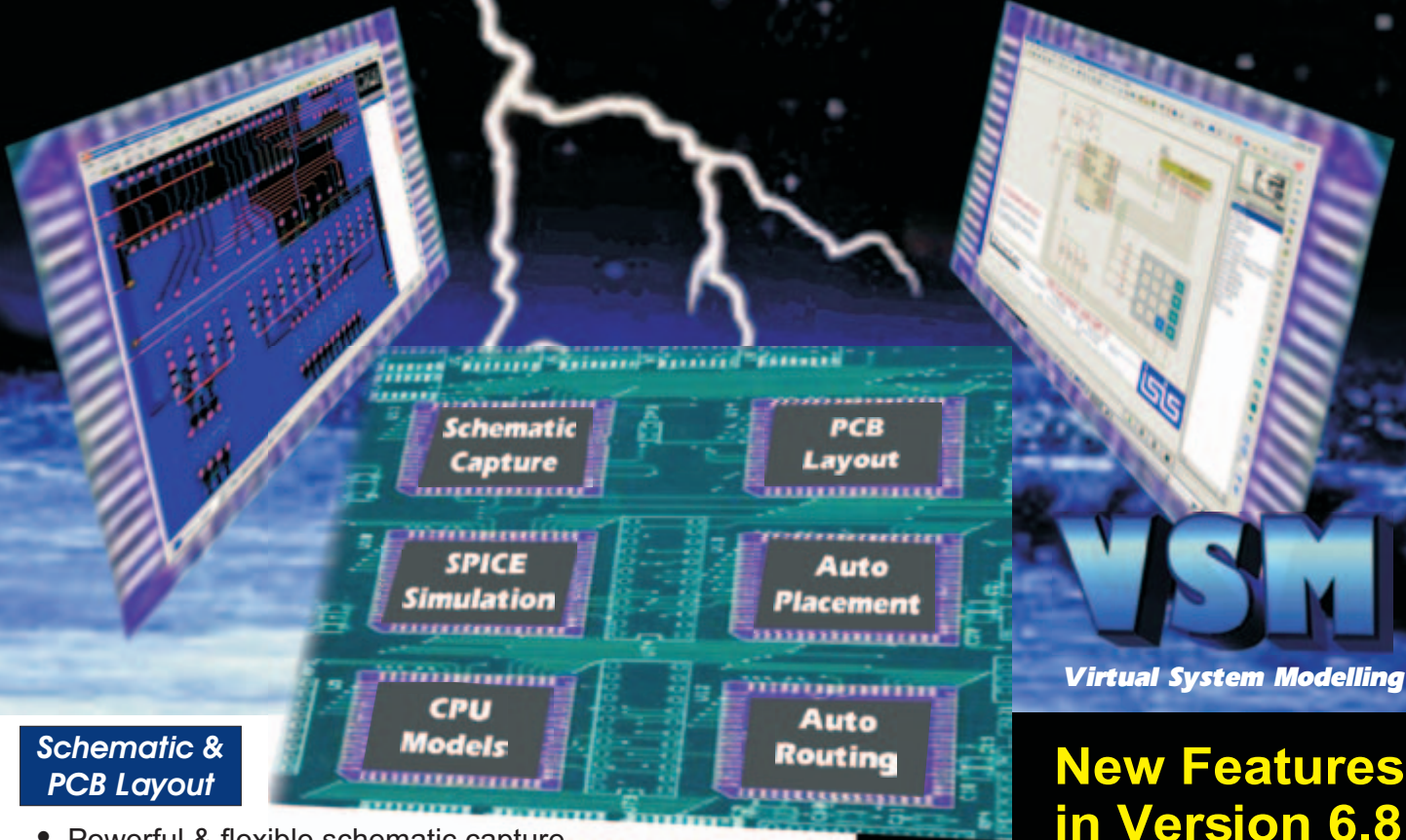

Schematic & PCB Layout

- Powerful & flexible schematic capture.
- Auto-component placement and rip-up/retry PCB routing.
- Polygonal gridless ground planes.
- Libraries of over 8000 schematic and 1000 PCB parts.
- Bill of materials, DRC reports and much more.

Mixed Mode SPICE Circuit Simulation

- Berkeley SPICE3F5 simulator with custom extensions for true mixed mode and interactive simulation.
- 6 virtual instruments and 14 graph based analysis types.
- 6000 models including TTL, CMOS and PLD digital parts.
- Fully compatible with manufacturers' SPICE models.

Proteus VSM - Co-simulation and debugging for popular Micro-controllers

- Supports PIC, AVR, 8051, ARM7 and BASIC STAMP micro-controllers.
- Co-simulate target firmware with your hardware design.
- Includes interactive peripheral models for LED and LCD displays, switches, keypads, virtual terminal and much, much more.
- Compatible with popular compilers and assemblers from Microchip, Crownhill, IAR, Keil, and others.

New Features in Version 6.8

- Interactive Design Rule Check.
- Mitring / Unmitring.
- Enhanced track editing.
- Struct/Array expansion.
- ELF/DWARF file loader.
- Expanded model libraries.

Call Now for Upgrade Pricing

**NEW
ARM/LPC2000**

**MODELS FOR
PROTEUS VSM
NOW AVAILABLE**

labcenter
Electronics
53-55 Main Street, Grassington. BD23 5AA

Tel: 01756 753440
Fax: 01756 752857

Contact us for
Free Demo CD

www.labcenter.co.uk
info@labcenter.co.uk