

ELEKTOR ELECTRONICS

SEPTEMBER 2003

£3.45

THE ELECTRONICS & COMPUTER MAGAZINE

www.elektor-electronics.co.uk

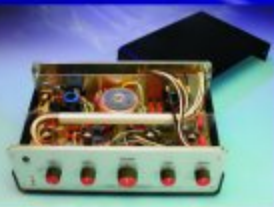

**Valve
Preamplifier**

PICPROG 2003

versatile PIC production programmer



**ATV Picture
Generator**

**MSC1210
Software & LCD**

**Valves at Low
Plate Voltages**

**Polyphonic
Doorbell**

**More Light
from LEDs**



PICProg 2003

A versatile PIC production programmer

Design by R. Brauns

This programmer was specially designed for those of you requiring a cheap way to program PIC microcontrollers, without sacrificing useful features as compared with professional programmers on the market. The circuit described here is capable of handling more than 85 different types of PIC micro!

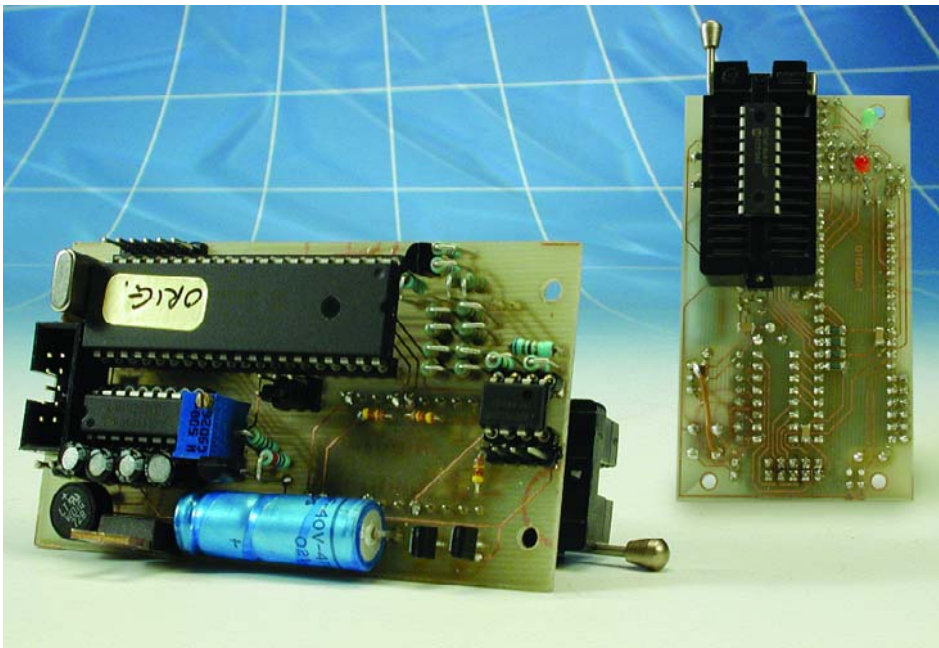

The popularity of PIC microcontrollers has seen a healthy increase these past few years, particularly when the first chips with Flash memory were introduced. Since the launch of the most popular member of the PIC family, the 16F84, dozens of successor types have made it to industrial as well as hobby use, not in the least thanks to projects and New Product releases published in *Elektor Electronics*. Of the more recent 'beasts' produced by Microchip, the PIC16F627/628 come to mind, or the PIC16F818/PIC16F819 which is

a perfect replacement for the PIC16F84. These micros offer, among others, extra hardware for an RS232 link, a PWM (pulsewidth modulation) module and additional timers.

If you require a microcontroller for heavier tasks (for instance, one with an on-chip ADC) then take a look around in the 16F87x series it is well worth your effort.

Microchip has replaced as number of EPROM based PICs (like those

Suitable for nearly all types from these PIC series:

12C(E)xxx
12Fxxx
16Cxxx
16Fxxx

in the 16C7x series) by Flashable versions. A number of Flash replacements are now also available for popular PICs from the 12Cxx series. For example, have a look at the 12F629 (with a unit price below £1) or its 14-pin sibling the 16F630.

Extensive information on all PIC microcontrollers may be found on the manufacturer's website:

www.microchip.com.

The website also has a wide variety of 'tools of the PIC trade' including datasheets, an assembler and development platforms for DOS as well as Windows.

As already intimated, this project is not just another standard programmer of which dozens may be found on the Internet and competing magazines. Valuable as they are, such programmers either have severe limitations in the number of PIC types they can handle, or they

simply do not work properly for some types proudly included in the 'supported devices' list. That is why we searched for an inexpensive solution to make a 'production programmer' (a term used by Microchip). The cost of our DIY programmer is about half that of comparable PIC programmers on the market, and the general design and quality is well beyond what may be expected from any of our competing magazines.

The programmer is connected to

the RS232 port on a host PC, using a 1-to-1 (i.e., non-crossed) RS232 cable. All you need in the way of a power supply is a commercial 15-VAC mains adapter capable of supplying 300 mA or more.

The project software has been implemented for Windows 95/98/NT/ME/2000/XP. Thanks to the Flash memory, the firmware in the controller on the programmer board is easily updated via the serial port, allowing you to install updates when new PICs are being introduced like, for example, the latest PIC18xxx types and the rapidly growing Flash family.

Finally, we hope that the publication of this programmer acts as a stimulant for you to consider using other PICs than the run-of-the-mill 16F84.

Circuit diagram

Despite the versatility of the PIC-Pro 2003, its schematic is relatively simple, see **Figure 1**. The heart of the circuit is formed by IC6, a ready-programmed PIC16F874-20P. It has been programmed to look after the programmer signal timing, the voltages at the programmer socket pins and, of course, the communication with the host PC.

The connection with a (free) serial port on the PC is established via K2. The data speed on the serial link is set to 115.2 kbits/s. RS232 signals are converted to TTL swing, and the other way around, by IC4. Bi-directional communication is made as reliable as possible by the use of the CTS and RTS handshaking lines on the RS232 interface. These lines force the system to 'idle' until received bytes have been processed. Of course, this handshaking will tend to slow down the communication a little. Fortunately, that is not a problem because no PIC contains more than 8 kbytes of

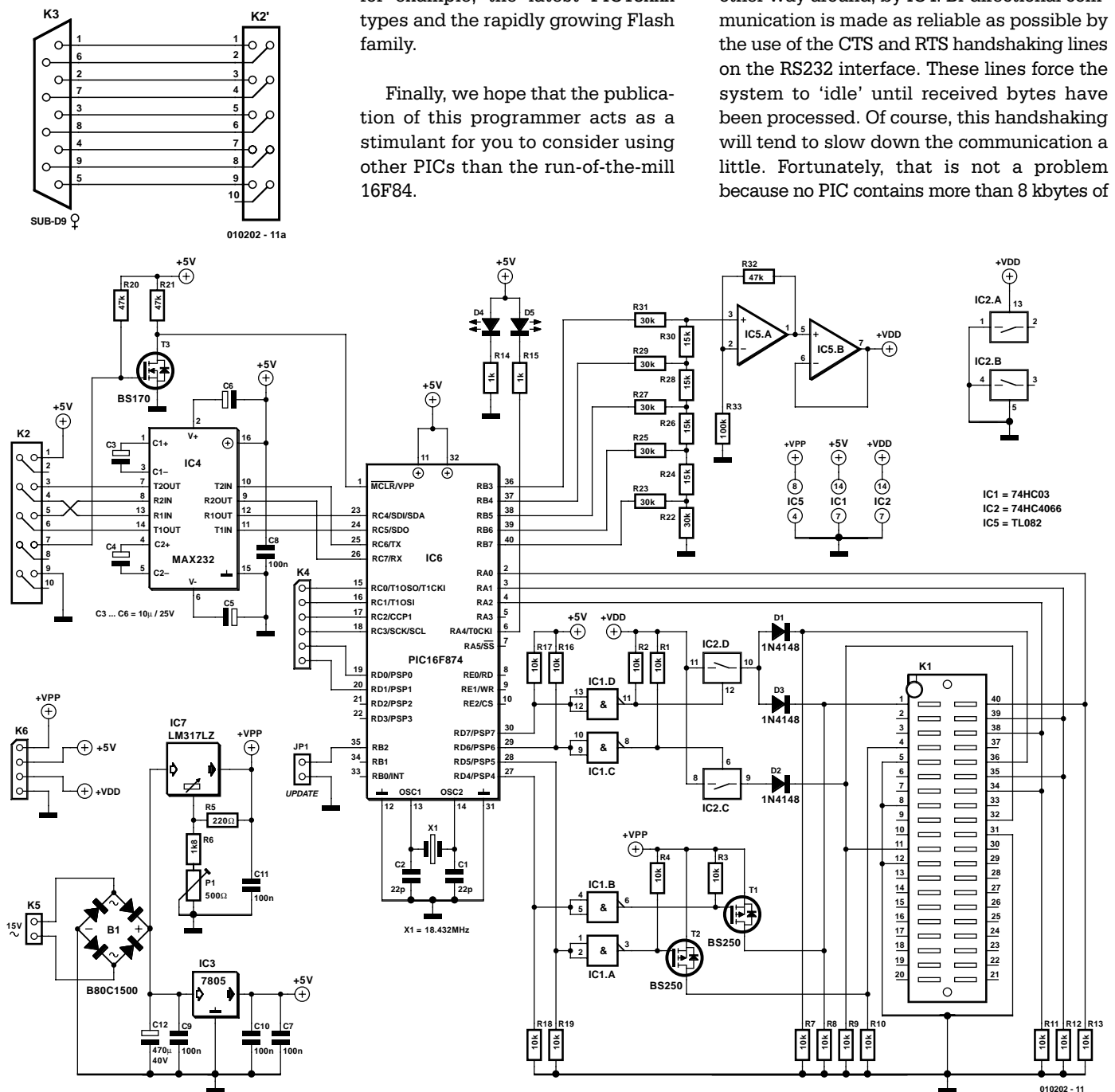

Figure 1. Despite the extremely versatile character of the PICPro 2003, its complexity remains with reason.

COMPONENTS LIST

Resistors:

- R1-R4, R7-R13, R16-R19 = 10kΩ SMD
- R5 = 220Ω
- R6 = 1kΩ
- R14, R15 = 1kΩ
- R20, R21, R32 = 47kΩ
- R22, R23, R25, R27, R29, R31 = 30kΩ 1%
- R24, R26, R28, R30 = 15kΩ 1%
- R33 = 100kΩ
- P1 = 500Ω preset, vertical, multiturn

Capacitors:

- C1, C2 = 22pF
- C3-C6 = 10μF 25V radial
- C7-C11 = 100nF SMD
- C12 = 470μF 40V axial

Semiconductors:

- D1, D2, D3 = 1N4148
- D4 = LED, green, 3mm, low-current
- D5 = LED, red, 3mm, low-current
- T1, T2 = BS250
- T3 = BS170
- IC1 = 74HC03 SMD
- IC2 = 74HC4066 SMD
- IC3 = 7805
- IC4 = MAX232
- IC5 = TL082CP
- IC6 = PIC16F874-20/P (programmed, order code **010202-41**)
- IC7 = LM317LZ
- B1 = B80C1500 (round case) (80V piv, 1.5A)

Miscellaneous:

- K1 = 40-way ZIF programming socket, plus a 10-way and a 12-way SIL contact strip
- K2 = 10-way boxheader
- K3 = 9-way sub-D socket (female), with IDC connector (not on PCB!)
- K4 = 6-way SIL pinheader
- K5 = 2-way pinheader
- K6 = 4-way SIL pinheader
- JP1 = 2-way SIL pinheader with jumper
- X1 = 18.432MHz quartz crystal
- 10-way IDC connector
- Length of 10-way flatcable
- Case, size 120 x 60 x 40 mm, e.g., Velleman # G410
- Connector for mains adapter, chassis mount PCB, order code **010202-1**
- Disk, Windows software, order code **010202-11** or Free Download
- Runtime files, file number **010202-12**, Free Download

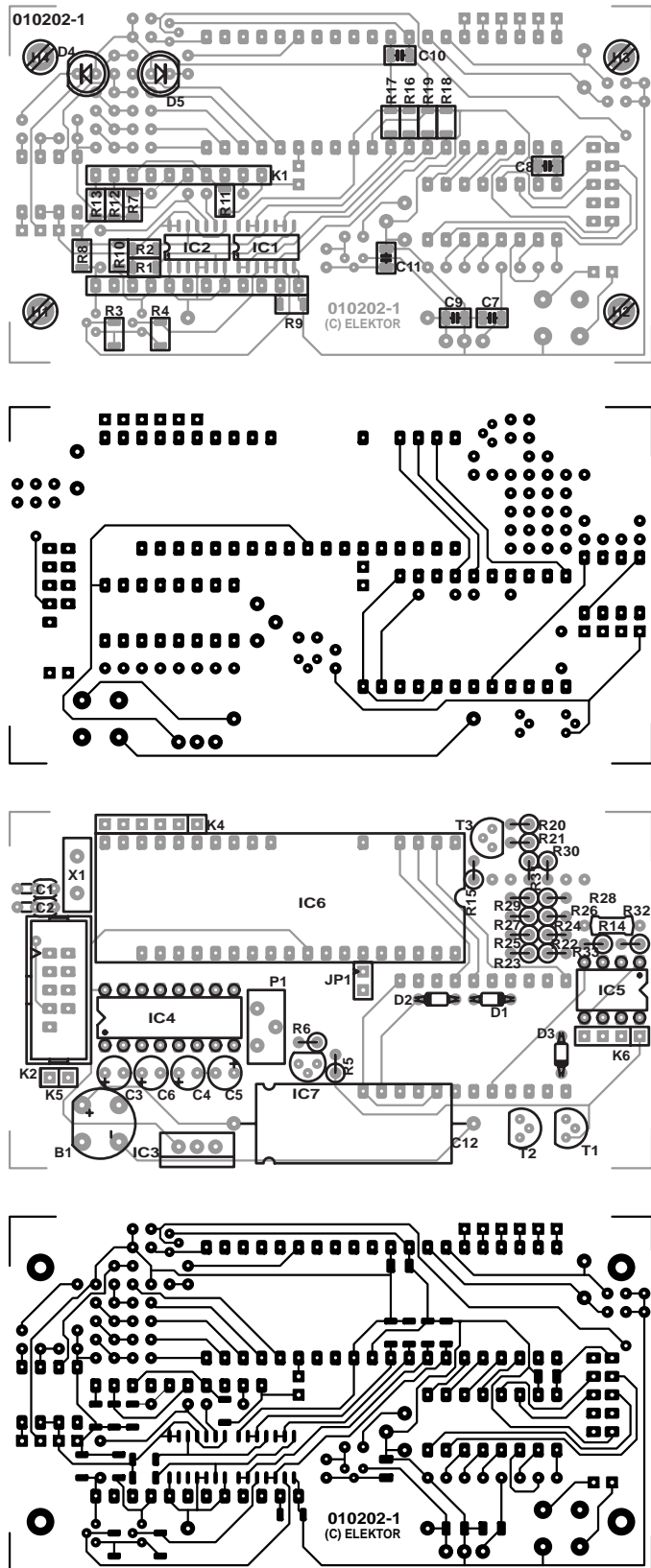

Figure 2. The double-sided board holds parts at both sides. One of these is the programming socket, K1 (board available ready-made).

program memory.

Components R22-R31 and IC5a/b together form a cheap and simple D-A converter with

a buffered output. This DAC is used to generate the variable supply voltage needed for the PIC to be pro-

grammed. This voltage has to be variable between 2 V and 6 V in 0,25 V steps. A simple R-2R resistor

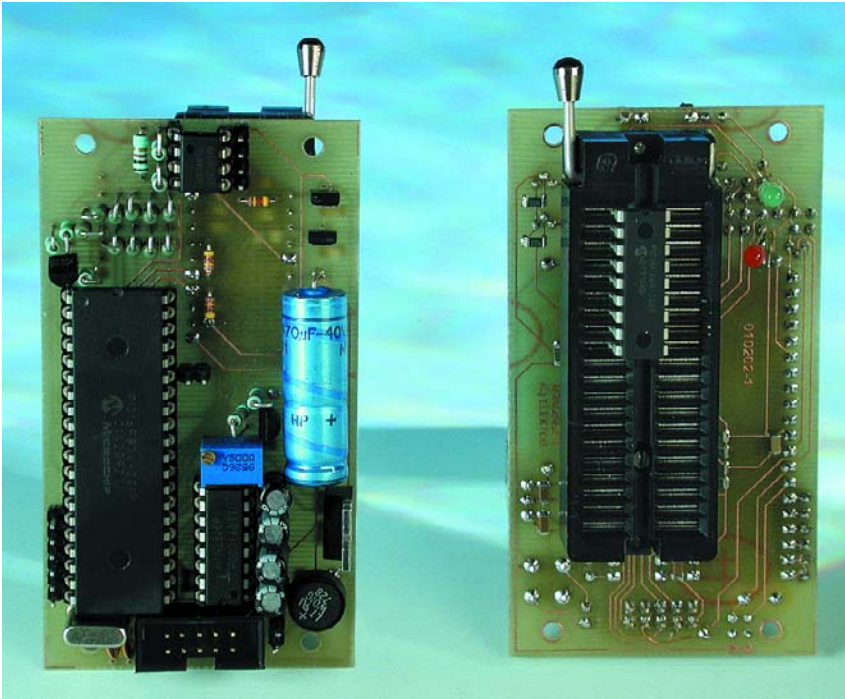

Figure 3. Top side and bottom side of the finished board (laboratory prototype).

ladder fits the bill perfectly, provided we use resistors with a tolerance not exceeding 1%.

The variable voltage is applied to the relevant pins of the programming socket K1 by way of electronic switches IC2c and IC2d. Once on the socket pin, the programmable voltage acts as V_{DD} for the PIC chip. Diode D3 protects switch IC2d against too high voltages at its output. After all, excessive levels may occur when T1 starts to conduct and 13 V arrives on pin 1 of K1. The other diodes are included to ensure a uniform voltage drop at all pins.

As already mentioned, a voltage of about 13 V is applied to the programming socket via T1 and T2. If the MCLR pin of the controller to be programmed is pulled to 13 V, the chip will enter programming mode. MOSFETs have been chosen in this design because of their low voltage drop across the conducting drain-source junction. The FETs as well as IC2 operate at different supply voltages with respect to 5 V. That is why the gates in IC1 provide a level adaptation between these components and controller IC6.

Four resistors, R16-R19, connected to GND or V_{cc} (5 V) have been included at the inputs of the gates in IC1. These resistors make

sure no voltage remains at the programming socket pins when IC6 is reset, since as at that instant all pins of IC3 are configured as inputs. Likewise, R7-R13 ensure that unused inputs or pins configured as an input are not allowed to 'float'.

Because a voltage of 13 V is needed in the programmer, it is not possible to resort to the use of a standard mains adapter of the DC type (a.k.a. 'battery eliminator'). Most mains adapters have a maximum output voltage of 12 V, and versions with a higher output voltage are expensive, hard to get, or both. We could have designed a DC/DC converter into the circuit, but that would have meant a considerable cost increase for the project. The problem has been solved by the use of a relatively inexpensive 15-VAC mains adapter. It should be noted, however, that most, if not all, DC adapters of the low-cost type supply much higher output voltages than specified (particularly at light loads) so do check with a voltmeter, you may have one that's suitable for this circuit.

Using B1 and C12 the adapter voltage is rectified and smoothed. The raw voltage is then applied to two regulators: IC3 for the 5-V rail and IC7 for the 13-V programming

voltage. The 13-V level may be accurately adjusted with the aid of P1.

Around RS232 connector K2 we find a small circuit comprising two resistors and a BS170 FET. These parts ensure that IC6 is automatically reset when no PC is connected. Also, a reset is generated at the start of every command (for example, reading the program memory). This is done to make absolutely sure the PICPro and the PC keep communicating even if an error occurs owing to external circumstances.

Connectors K4 and K6 are provided for future extensions. The author has plans to develop a module for ISP (in circuit programming), which he hopes to be able to mount under the programmer board.

The executable code inside IC6 may be updated in a simple manner using a special Windows program. This requires jumper JP1 to be fitted first. Normally, this jumper is omitted for security reasons!

The green LED, D4, indicates that the circuit receives its supply voltage. The red LED, D5, lights when voltages are being applied to the programming socket. **In this condition, ICs should not be inserted into the ZIF socket or removed from it.**

Construction

All components are accommodated on a double-sided, through-plated printed circuit board, of which the artwork is shown in **Figure 2**.

If you decide to use IC sockets for positions IC4, IC5 and IC6 than go in sockets with turned pins. Most resistors are mounted vertically. Like the printed circuit board, the ready-programmed PIC may be ordered through the *Elektor Electronics* Readers services, the order code is **010102-41**.

Two SMD integrated circuits, a number of SMD passive components and programming socket K1 are mounted **at the solder side of the board**. The SMD parts have to be fitted accurately using a minimum amount of solder and a soldering iron with a fine tip.

Having fitted all parts on to the board, it is time for a thorough visual inspection of your work so far. If everything appears to be in order, the PCB may be mounted in a suitable ABS case (see parts list). The RS232 connector and the mains adaptor socket are mounted on to the case and connected to K2 and K5 using short cables. The RS232 connection may take the form of a short piece of flatcable with press-on (IDC) connectors, provided you have the matching 9-way sub-D connector.

Before you solder the LED terminals in place, check their lengths to make sure the

LEDs can be seen through the two holes in the case.

The programming socket is a 40-way ZIF (zero insertion force) type with wide slots so

that narrow DIP ICs can be programmed also. At the solder side of the board, first solder a 10-way and a 12-way SIL socket strip in position

K1. Next, insert the ZIF socket into these receptacles, making sure pin 1 of the ZIF socket is beside resistor R8. If the socket does not protrude

Two Windows programs

The installation of the two Windows utilities for the PICProg 2003 programming system is rather simple: copy the folders **PicProg** and **Update**, complete with their contents, to a suitable directory on the hard disk. Next, create desktop shortcuts to the programs **Pcprog.exe** and **Update.exe**. If error reports pop up, these are probably caused by a number of missing Visual Basic runtime modules. If necessary, you may download them from the Elektor Electronics website, the file number being **010102-12**. Next, copy the modules into the Windows/System/ folder. Fortunately, the runtime modules are already present on most reasonably modern PCs.

Main program 'PicProg'

The screenshot opposite shows the program PicProg in action. The menu options are briefly discussed below.

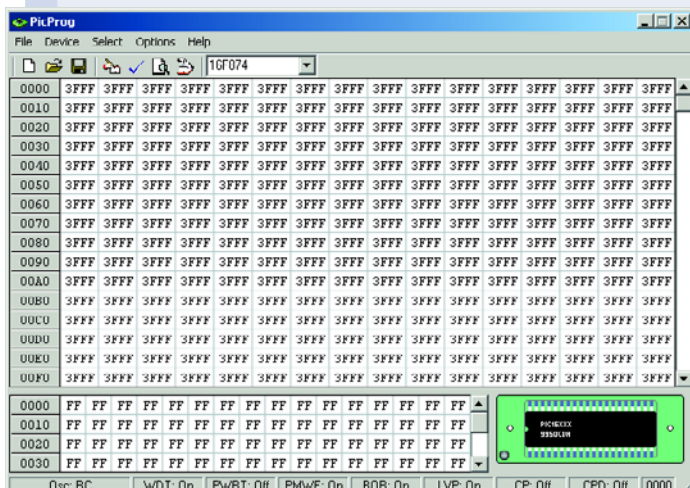

Menu bar, button bar and status bar

At the top of the window you'll find the button bar for the various commands.

File allows *.hex files to be opened, saved, etc. Device opens a list of commands for programming, reading, testing and erasing PICs. Using **Select/Device** you are able to choose the PIC type to be programmed. Furthermore, **Select/Fuse Word** allows the famous PIC configuration byte to be defined. Finally, there's **Device/IS Loc** which opens the Editor for entering ID byte values.

Options/Select COM has the obvious function of letting you choose a free COM: port on your PC. The first time the software is used, it will automatically select the first free COM: port found on the system, and then save the setting in the 'Update.ini' file. If problems occur with the selection of the port, 'Update.ini' may be edited manually (for example, using Notepad) to select the port you want. The file may be found in the program directory.

Program memory

The large window shows the program memory contents using hexadecimal notation. The value at each address location may be changed using an editor, which is opened by putting the cursor on

a location and double-clicking or pressing the [Enter] key. The editor then allows you to enter the new hexadecimal value.

The start addresses of the rows are shown in the grey boxes at the left-hand side. If the cursor is placed on a certain location, the associated address is displayed (in hexadecimal) at the far right in the status bar.

The scroll bar at the right-hand side of the window allows you to scroll through the entire program memory.

Data memory

The second, somewhat smaller, window displays the data (EEP-ROM) memory, if available in the selected PIC chip. With EEPROM-less PICs, this area will be inactive. The use of this window is identical to that of the main window discussed above.

Programming socket

Right beside the small window you'll see an image of the ZIF programming socket with the selected PIC inserted. This is intended to help you avoid wrong insertions, and obviates an ugly and possibly confusing decal on the case.

Working without hardware

Without the programmer connected up, a window will pop up within a few seconds after starting the program, telling you: 'No programmer connected. Please connect the programmer and run the program again'. If you press 'OK' the program will automatically quit. By pressing 'Cancel' the program may be used as a simple hex editor, without access to the program and read functions. Also, a different COM: port may be selected.

Firmware Update utility

A separate program is available for updates to the programmer board firmware (stored in IC6). An update entails downloading new object code in the firmware PIC, IC6. The update mode is selected by fitting jumper JP1. The red LED will light. Once the update is completed, the LED will go out again. If the LED starts to flash, an error has occurred in the download process, which should be repeated until the LED goes out. During the update operation, the program shows the state of the data transfer.

The menu bar contains roughly the same functions as the main program. Most menu options are self evident. Using **Device/Update** you launch an update after having loaded a file (otherwise, the function is not available). If JP1 is not fitted on the programmer board, a message will pop up requesting you to do so.

Once the new code has been successfully copied into IC6, the system will display 'Update Done', whereupon the jumper may be removed and the programmer board switched off and on again to use the PicProg 2003 with its new firmware.

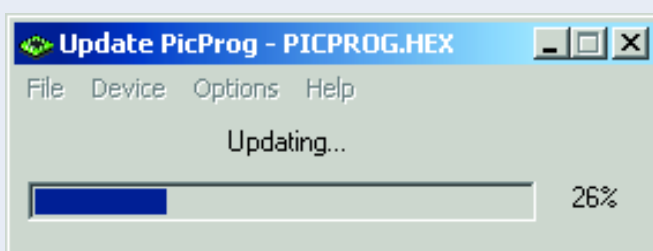



far enough from the case, its height may be adjusted by stacking up extra socket strips.

Software

The software developed for the PICPro 2003 programming system

comes in two parts: the executable code (object code) for IC6 and the Windows software to control the programmer using your PC. The code for IC6 contains a number of routines that look after the communication between IC6 and the PIC device to be programmed. There are also com-

plete read and program algorithms for the supported PIC devices. The code can be updated any time.

Finally, the last 256 bytes of code contain the RS232 routines and the setup routines of the various I/O pins and registers, as well as a routine that allows the remaining part of the program memory to be updated. That particular part is protected to prevent it accidentally being written to, although the update routine only allows valid addresses (valid meaning from 0x0004 to 0x0EFF).

The Windows software consists of two utilities: 'PicProg' which looks after all programming tasks and 'Update PicProg' for updating the object code (firmware) in IC6. The functionality of these two programs is discussed in the inset. The author plans to supply frequent updates of the programs as well as the hex code to ensure the PICProg 2003 project remains 'aware' of the latest developments in PIC land. If and when available, updates will be posted on the *Elektor Electronics* website.

(010102-1)

Advertisement

Valve Preamplifier (I)

Classic technology revisited

Design by B. Stuurman

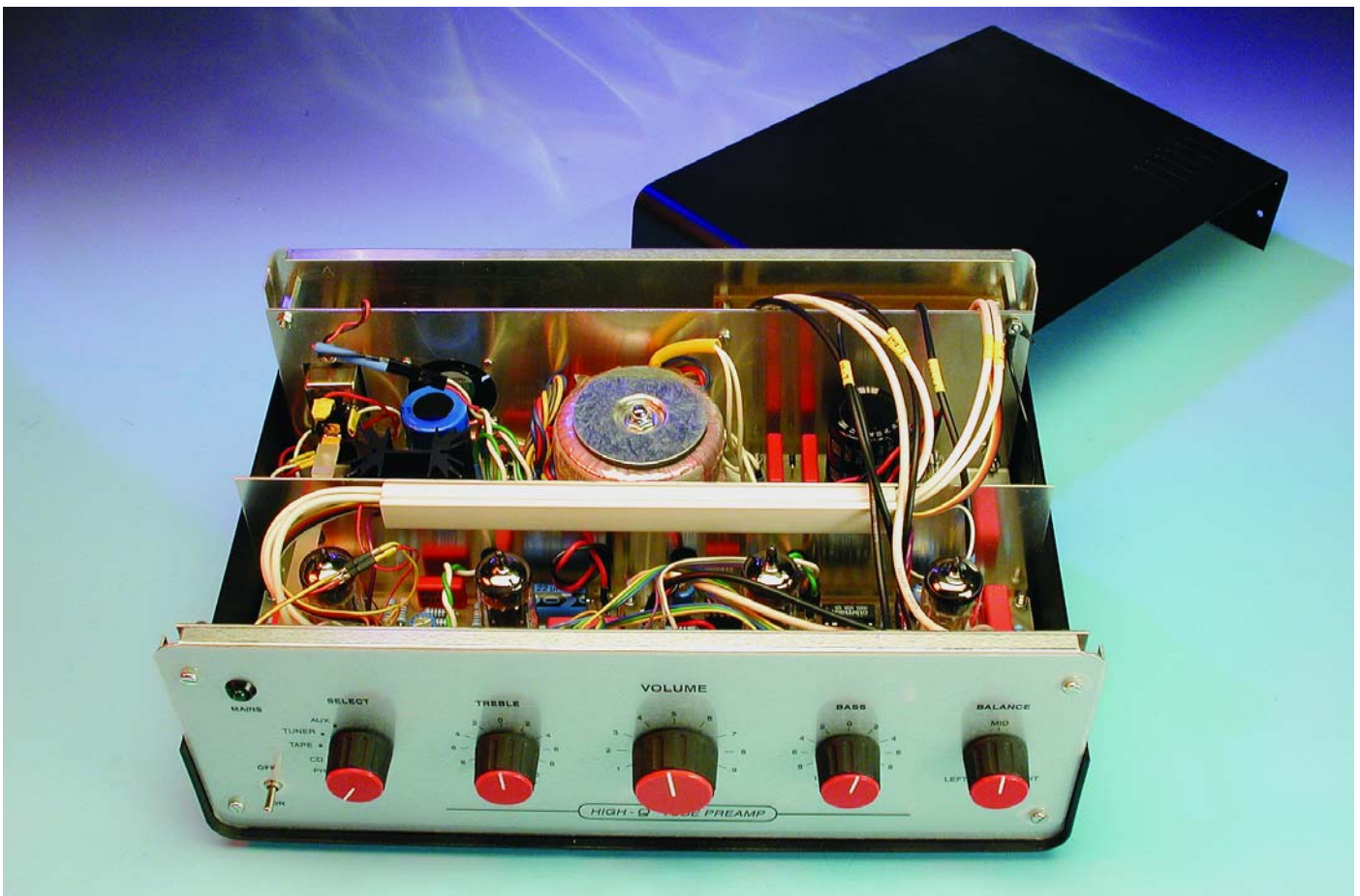

This stereo preamplifier is primarily intended to be used as a companion to the Valve Final Amplifier described in the April and May 2003 issues, but it can easily be used with other power amplifiers as well. The circuit has all the usual controls and input options, and it is relatively easy to build, even if you're not a valve guru.

Like most preamplifiers, this one has controls for volume, tone (treble and bass) and balance. The input options also correspond to the usual scheme, the only exception being

that this preamplifier has a phono input — which can no longer be taken for granted these days. The complete stereo version consists of

five printed circuit boards: an amplifier board for each channel, an I/O board holding all the Cinch connectors and relays, a high-voltage sup-

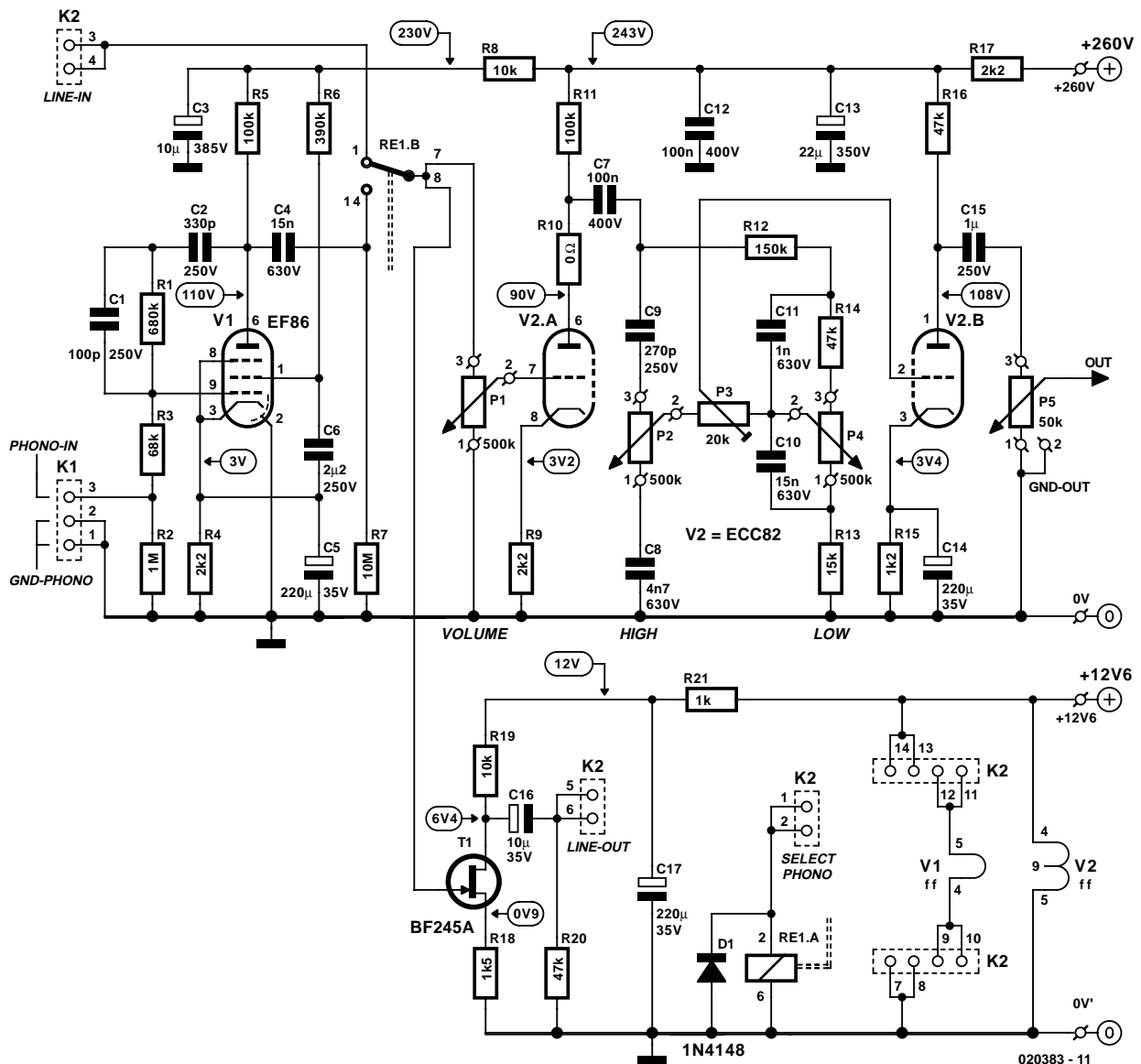

Figure 1. The active components of the preamplifier consist of an EF86 and an ECC82. FET T1 is a 'bonus'.

ply board and a low-voltage supply board. The last of these provides 12.6 V DC for the valve filaments, among other things.

Two valves

As can be seen from the schematic diagram of the amplifier (**Figure 1**), no overall feedback is used, but only local feedback in the phono preamplifier. This is because valves are manufactured to such tight tolerances that excellent results can be achieved even without using feedback.

The circuit is quite simple. The actual control amplifier is built around V2a and V2b, an ECC82

(12AU7). Volume control P1 is placed directly at the input of the control amplifier, and a relay is used to select one of two possible signal sources: the output of the phono stage or the line input (pins 3 & 4 of K2). The tone control is placed between V2a and V2b. This is a passive control using logarithmic potentiometers. P5 is included at the output of V2B to adjust the balance.

Amplifier details

The phono preamplifier is built according to a modified Philips design, using an EF86 or its equivalents the 6267 or CV2901 (V1). This is an outstanding valve for this pur-

pose, due to its low noise and minimal microphonics. The necessary RIAA compensation is obtained by using frequency-dependent feedback. At the average output level of an MD cartridge, the output voltage of the phono stage is approximately 54 mV, which is also the input sensitivity of the following control amplifier.

K2 is the Line input. A CD player, tuner or the like can be connected here via the I/O board (which is described below). Relay Re1 is normally connected to the Line input, and the CD player, tape, tuner or auxiliary input is selected by a relay on the I/O board.

Despite our original intention, it was ultimately decided to add a Line output (K2) to allow recordings to be made. This output should be regarded as a sort of extra, since the FET amplifier stage used here (T1) is a

I/O circuit

The I/O circuit shown in **Figure 2** contains all of the cinch connectors for the preamplifier, which are fourteen in total. Attenuators are included in series with the CD, Tape, Tuner and Aux inputs. They consist of resistors R1–R4 (or R6–R9 for the second channel) and the common resistor R5 (or R10). The amount of attenuation can be adjusted as necessary by modifying the values of the series resistors. This may be necessary with the CD input in particular, since some CD players provide an output voltage that is several times greater than the line input sensitivity of 250 mV used here. By the way, if you use a series resistor with sufficiently high resistance for the Aux input (e.g., 220 kΩ), you can connect a phonograph with an old-fashioned ceramic hi-fi cartridge directly to the Aux input. This type of cartridge provides a sufficiently high output voltage and does not require RIAA compensation, as do MD cartridges.

Relays are used to keep the wiring of the inputs simple. A switchover relay is located on each of the amplifier boards. When it is energised, the output of the phono stage is connected to the input of the control amplifier, while otherwise the output of the I/O board is connected to the input of the control amplifier. The CD, Tape, Tuner and Aux inputs on the I/O board are connected to the Line In input via relays Re1–Re4 (or Re5–Re8 for the second channel). The desired input is selected by energising the associated relay.

One final remark regarding the I/O circuit: if you are not absolutely certain that the outputs of all of your signal sources are free of DC voltages, it is recommended to place 2.2-μF MKT (metallised plastic) capacitors in series with Line In, between the I/O board and the amplifier boards (Cx and Cy in Figure 2).

Power supply

The preamplifier requires two supply voltages: a high voltage of 260 V and a filament voltage of 12.6 V. In order to avoid availability problems, two standard toroidal-core transformers

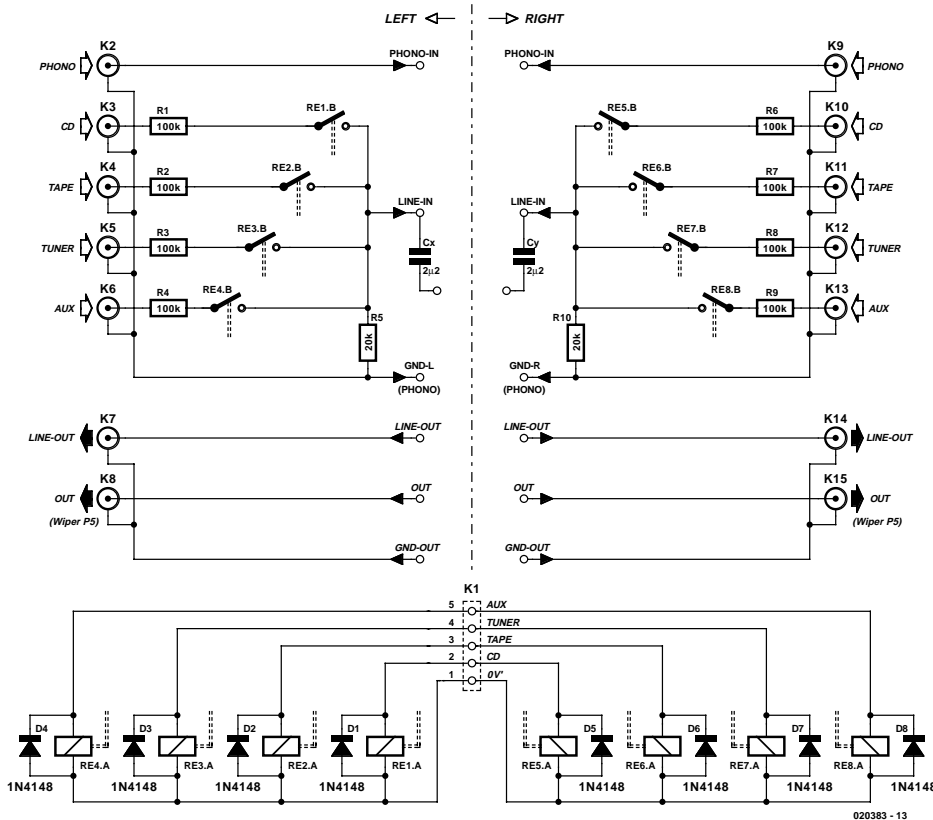

Figure 2. The I/O circuit uses relays to dramatically reduce the amount of wiring.

‘foreign’ element in a valve amplifier.

The tone control, in which P2 adjusts the treble and P4 adjusts the bass, is a standard circuit. At the ‘straight-through’ setting, the control has an attenuation factor of 14, which means that quite a bit of gain is necessary to achieve the input level required by the valve final amplifier described in the April and May issues. This gain is provided by an ECC82 (12AU7) dual triode (V2). Each triode section provides a gain of approximately 11, so the total gain is more than adequate.

The balance control (P5) of this amplifier is rather unusual. Although a ‘normal’ balance potentiometer could be used here, two log-taper potentiometers were used in the prototype (one for each channel). When a log-taper potentiometer is at the centre of its mechanical range, it is set to approximately 16 percent of its total electrical resistance. With a 50-kΩ potentiometer, the resistance between the wiper and the start of the track is then 8 kΩ, while the resistance between the wiper and the end of the track is 42 kΩ. If the potentiometer is wired in reverse, the additional series resistance (when the potentiometer is set to the midrange position) can be limited to 8 kΩ, while still allowing the signal to be reduced to zero. The two (single) poten-

tiometers must be mechanically coupled such that they rotate in opposite directions. This can be easily done using a pair of gears.

The power supply provides a filament voltage of 12.6 V. An ECC82 can be directly connected to this voltage, but an EF86 can only be connected to 6.3 V, so two valves (one on each of the two amplifier boards) must be connected in series when a 12.6-V supply is used. This can be easily done using connector K2. For one channel, pins 7, 8, 9 and 10 are connected together using jumpers, while for the other channel, pins 11, 12, 13 and 14 are connected together. After this, pins 11 and 12 for the first channel are connected to pins 9 and 10 of the circuit board for the second channel. For a mono amplifier, a 330-Ω, 2-W resistor can be inserted in the circuit.

The final detail is that in our version of the amplifier, a wire link was used in place of R10. If the gain of the ECC82 proves to be too large, a resistor can be fitted to convert R1 and R11 into a voltage divider.

are used here. The first transformer (Tr1) converts the mains voltage to 15 V. After rectification and stabilisation, this voltage is used to power the filaments. The secondary voltage is also converted back to approximately 230 V by the second transformer (Tr2). The toroidal-core transformers have practically no external magnetic fields, so they are hum-free. They can be mounted one on top of the other in order to save space in the enclosure.

The complete schematic diagram of the power supply is shown in **Figure 3**, with the low-voltage portion at the bottom and the high-voltage portion at the top. Tr1 is a 30-VA type, while Tr2 is a 15-VA type (the smallest in the series). The transformers have two secondary windings, which are connected in parallel. Rectification is provided by D1–D4 and D5–D8. A noise-suppression capacitor is connected in parallel with each diode, in order to slow down the switching of the diodes and thus prevent them from generating RF interference. C9 and C11 are the buffer capacitors for the low voltage and high voltage, respectively. The ground terminal (0 V) of the low-voltage supply is labelled '0V'.

The low voltage is stabilised by an adjustable voltage regulator using the well-known LM317. Trimpot P1 can be used to adjust the output voltage to exactly 12.6 V. If jumper J1 is fitted, the voltage divider is changed such that the output voltage can be set to 6.3 V. This allows the power supply to also be used for simpler valve circuits, although the amount of current that can be drawn in this configuration is much less (approximately 400 mA). C10 improves the transient response, and LED1 indicates that the power supply is operating. In addition, the LED and R4 provide a minimum load in the absence of an external load, to ensure that the required minimum operating current is drawn from the IC.

The job of the IRF740 MOSFET (T1) in the high-voltage portion of the supply is to largely eliminate 100-Hz ripple. For a normal load current of 50 mA (each control amplifier needs approximately 15 mA), the ripple voltage across C11 is

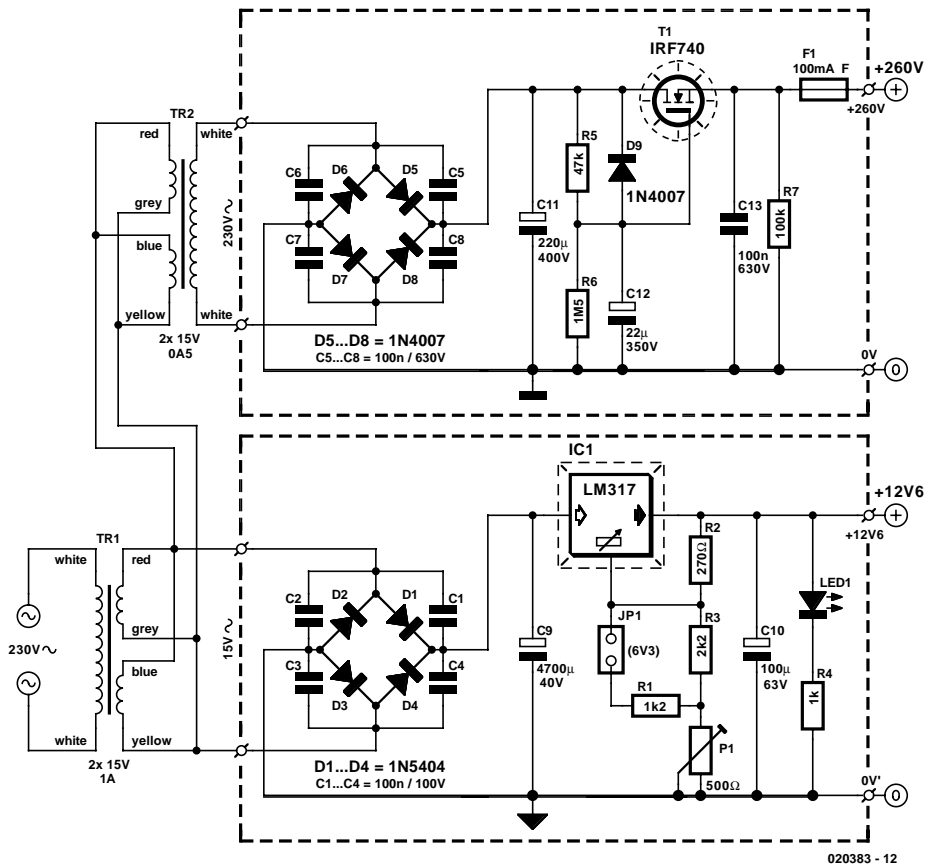

Figure 3. The power supply consists of separate high-voltage and low-voltage sections.

$$U_r = 1.7 (I / C) = 1.7 (50 / 220) = 0.4 \text{ V}$$

where:

U_r = peak-to-peak value of the ripple voltage

I = load current in mA

C = value of C11 in µF

If we provide a ripple-free voltage at the gate of T1, such that this voltage is much lower than the ripple voltage and provides sufficient leeway for variations in the mains voltage, the voltage on the output (source of T1) will also be free of ripple. Here R5, R6 and C12 provide the necessary voltage.

The circuit around T1 also provides a 'soft-start' characteristic for the high voltage supply. After the supply is switched on, the high voltage increases gradually and attains its final value after approximately 3 seconds. It also decreases gradually when the supply is switched off, due to the large capacitance of C11. These soft-start and soft-stop characteristics prevent switch-on and

switch-off pops. D9 discharges C12 after the supply is switched off, R7 ensures that no voltage is present at the output after a few minutes and C13 provides HF decoupling. Fuse F1 protects T1 in the event of a short circuit on the output. Incidentally, it is not necessary to use an external heat sink for the FET, even if it has to supply 50 mA.

Construction

Amplifier circuit board

The printed circuit board for the control amplifier is shown in **Figure 4**. Although it is certainly not difficult to build, a few remarks are in order.

Sockets with plastic bodies are used for the valves. These sockets are fitted to the component side of the board, as usual. The SIL connectors for K1, K2, P1, P2, P4 and P5 are supplied in long strips, and individual lengths can be sawn off using a coping saw with a metal-cutting blade. Each connector has at least two contacts, so they cannot twist around. To minimise the chances of incorrect connections, male contacts are used on the amplifier board and female contacts are used on the I/O board.

For some of the capacitors, the board is

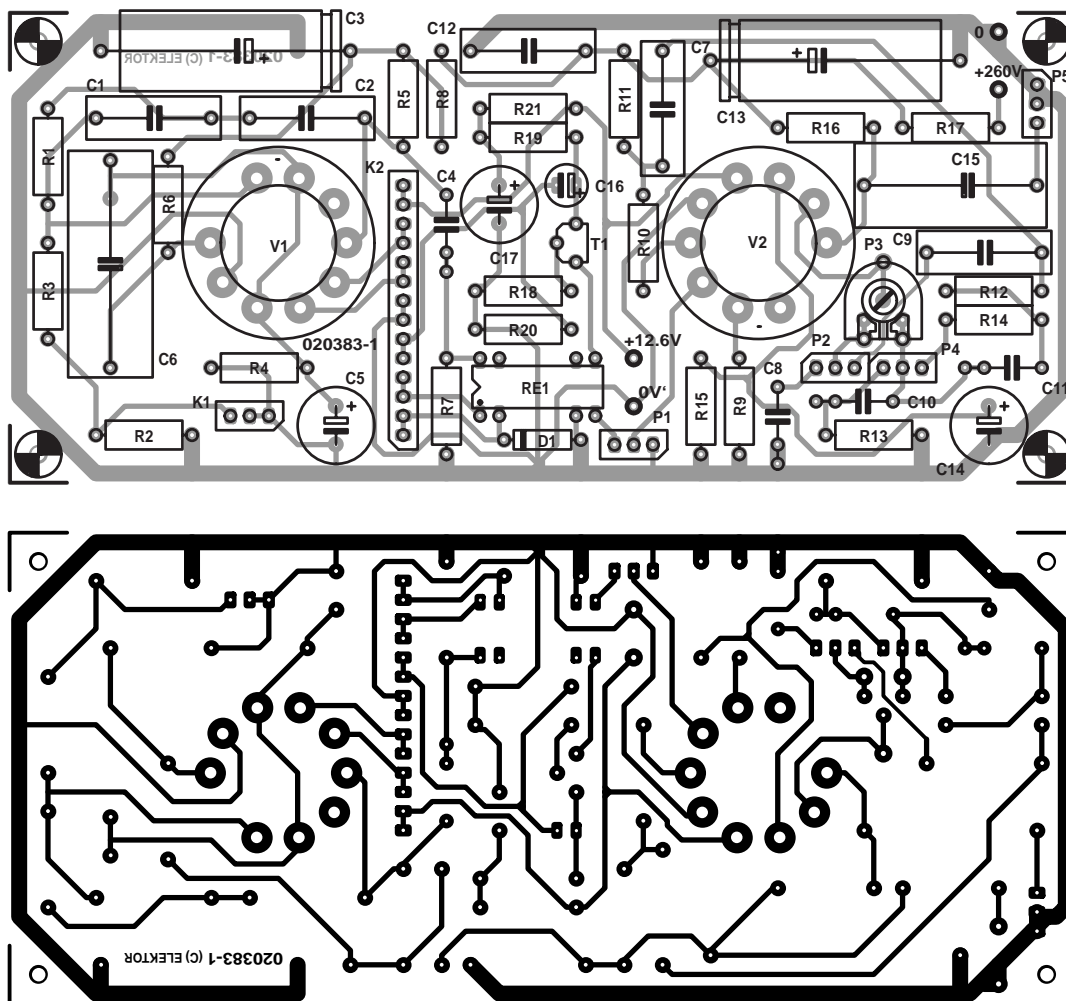

Figure 4. The printed circuit board for a single-channel (mono) amplifier board. Two such boards are needed for a stereo preamplifier.

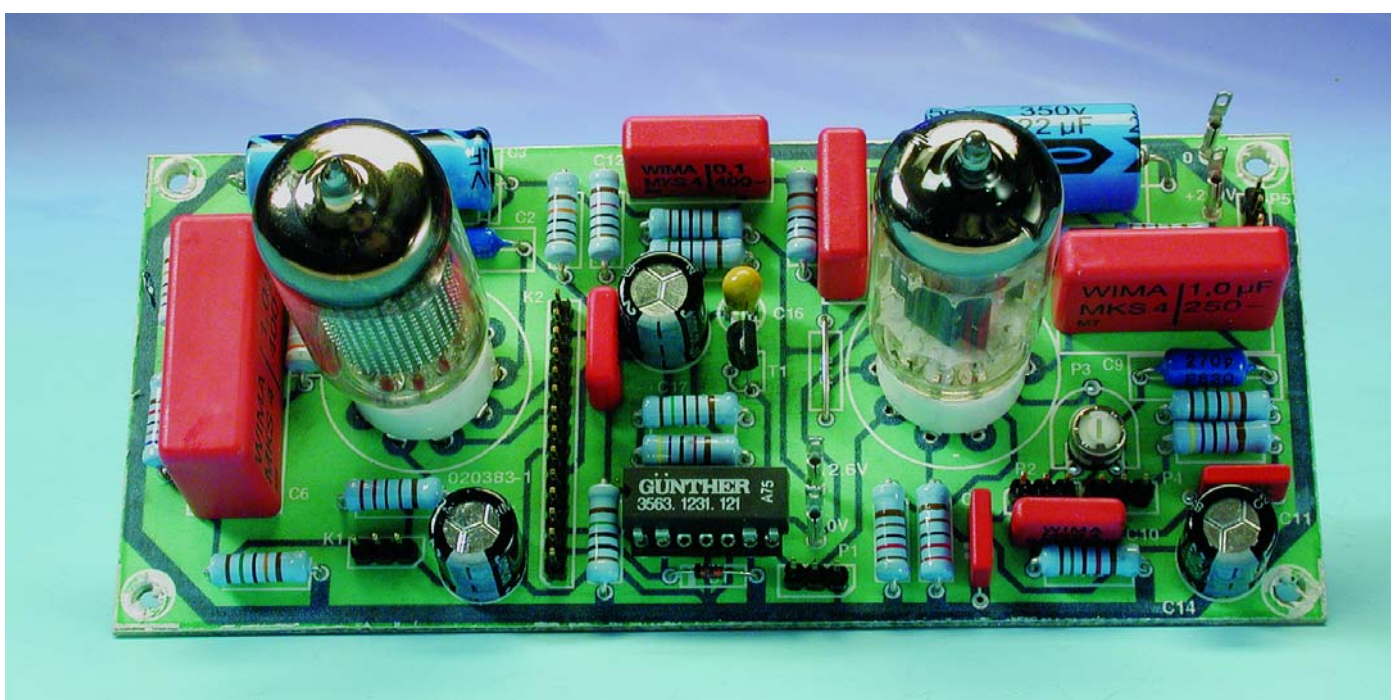

Figure 5. You can check your fully assembled amplifier board against this photo.

COMPONENTS LIST
Amplifier board

Resistors:

- R1 = 680kΩ
- R2,R12 = 150kΩ
- R3 = 68kΩ
- R4,R9,R17 = 2kΩ
- R5,R11 = 100kΩ
- R6 = 390kΩ
- R7 = 10MΩ
- R8,R19 = 10kΩ
- R10 = 0Ω (wire link, see text)
- R13 = 15kΩ
- R14,R16,R20 = 47kΩ
- R15 = 1kΩ
- R18 = 1kΩ
- R21 = 1kΩ

All resistors: metal film 0.5-1W, e.g., Beyschlag MBE-0414

P1,P2,P4 = 500kΩ logarithmic, stereo

- P3 = 20kΩ preset, horizontal, lead pitch 5.08/2.54mm (Conrad Electronics # 424420) or 5/10mm
- P5 = 50kΩ logarithmic

Capacitors:

- C1 = 100pF 250V polypropylene, e.g. Conrad Electronics # 458686
- C2 = 330pF 250V polypropylene, e.g., Conrad Electronics # 458740
- C3 = 10μF 385V, axial, 12x30 mm
- C4,C10 = 15nF 630V, lead pitch 10mm
- C5,C14,C17 = 220μF 35V, radial, lead pitch 5mm
- C6 = 2μF 250V, lead pitch 27.5mm or 22.5mm
- C7,C12 = 100nF 400V, lead pitch 15mm
- C8 = 4nF 630V, lead pitch 10mm or 7.5mm
- C9 = 270pF 250V polypropylene, e.g., Conrad Electronics # 458732
- C11 = 1nF 630V, lead pitch 10mm or 7.5mm

- C13 = 22μF 350V, axial, 16x36 mm
- C15 = 1μF 250V, lead pitch 22.5mm
- C16 = 10μF 35V tantalum, lead pitch 2.5mm

Valves:

- V1 = EF86, 6267 or CV2901
- V2 = ECC82, E82CC or 12AU7

Semiconductors:

- T1 = BF245A
- D1 = 1N4148

Miscellaneous:

- Rel = DIL relay, 1x changeover, 12V coil.
- 2 Noval (9-pin) valve sockets, PCB mount, pin circle 18mm, e.g., Conrad Electronics # 120529.
- IC socket, 14-way, turned pins (for Rel).
- 36-way pinheader, straight.
- 36-way socket, straight.
- 4 PCB solder pins with mating sockets.
- PCB, order code 020383-1 (see Readers Services).

laid out for two different sizes, so it should always be possible to find a suitable type. PCB pins are used for the high voltage and filament voltage connections.

The voltages shown on the schematic diagrams are valid when one amplifier board is connected to the power supply. Variations of up to 10 percent are possible. The voltage on the drain of T1 may range from 6 to 9 V. If this is not the case, replace the FET, since there can be a large

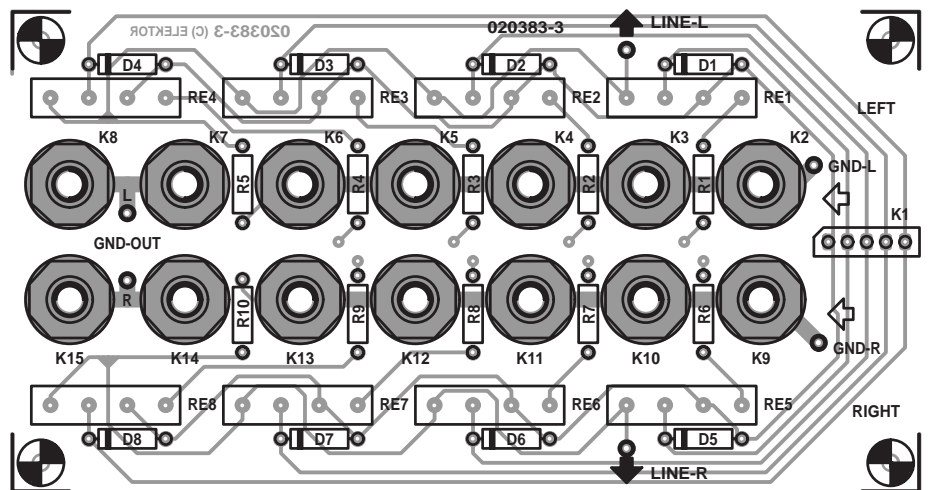

COMPONENTS LIST
I/O board

Resistors:

- R1-R4, R6-R9 = 100kΩ
- R5,R10 = 20kΩ

Capacitors:

Cx,Cy = 2μF2 MKT (metallised plastic) (see text)

Semiconductors:

D1-D8 = 1N4148

Miscellaneous:

- Rel-Re8 = SI relay, 1 make contact, 12V coil, e.g., Conrad Electronics # 504602.
- 14 cinch chassis sockets.
- SIL PCB header, 5-way.
- 6 solder pins with mating sockets.
- PCB, order code 020383-3 (see Readers Services)

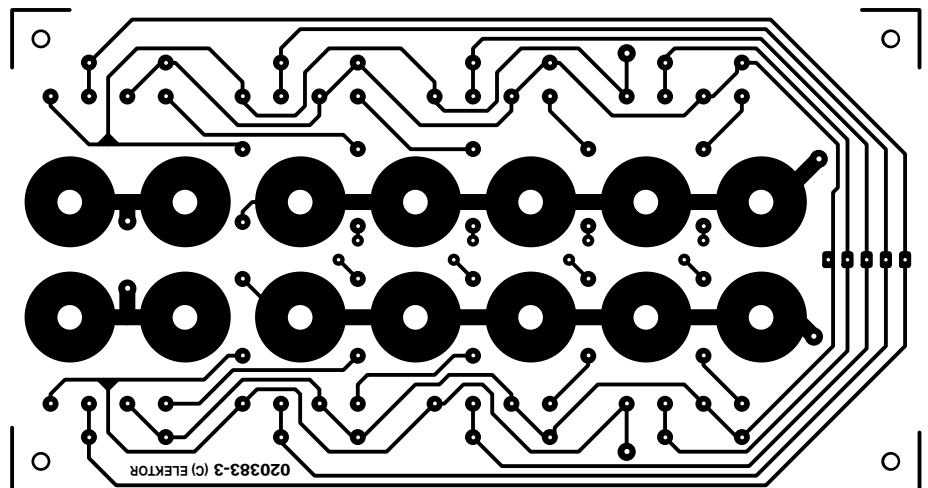

Figure 6. The I/O circuit board can be used directly as a connector panel. 'L' and 'R' naturally stand for 'left' and 'right'.

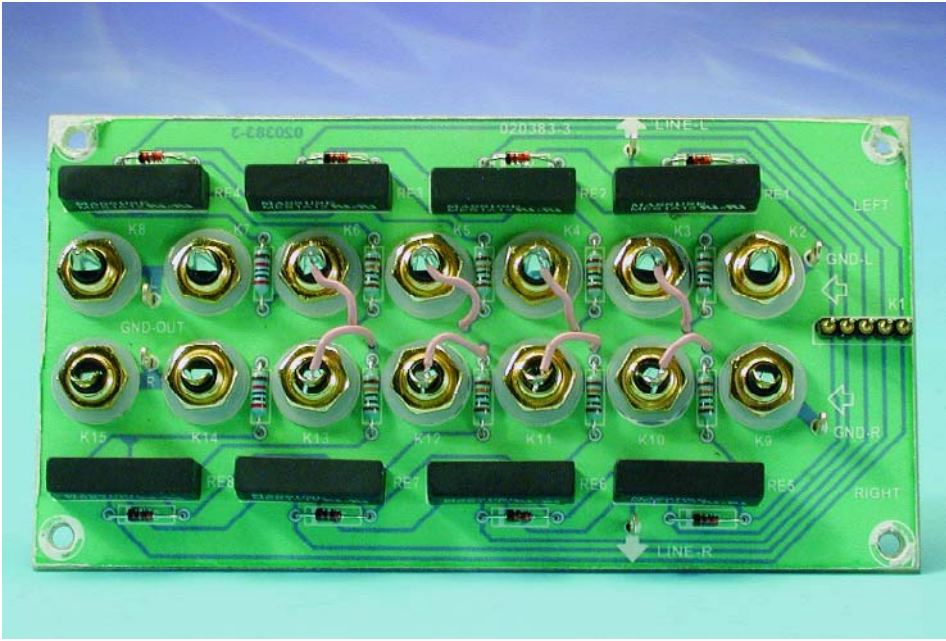

Figure 7. This photo shows how the components should be mounted on the I/O circuit board.

amount of individual variation in the FET characteristics.

A photograph of the fully assembled amplifier board is shown in **Figure 5**.

I/O circuit board

The printed circuit board for the I/O circuit is shown in **Figure 6**.

Tin the ground surfaces before the fastening the cinch connectors to the board. The inputs of the connectors are located on the copper side of the board. Place the supplied spring washers under the nuts and firmly tighten the nuts. Fit the other components only after the Cinch connectors have been fitted.

Each stereo channel has two ground points, labelled 'Gnd Out' and 'Gnd L/R In', which must be connected to the corresponding points on the control amplifier

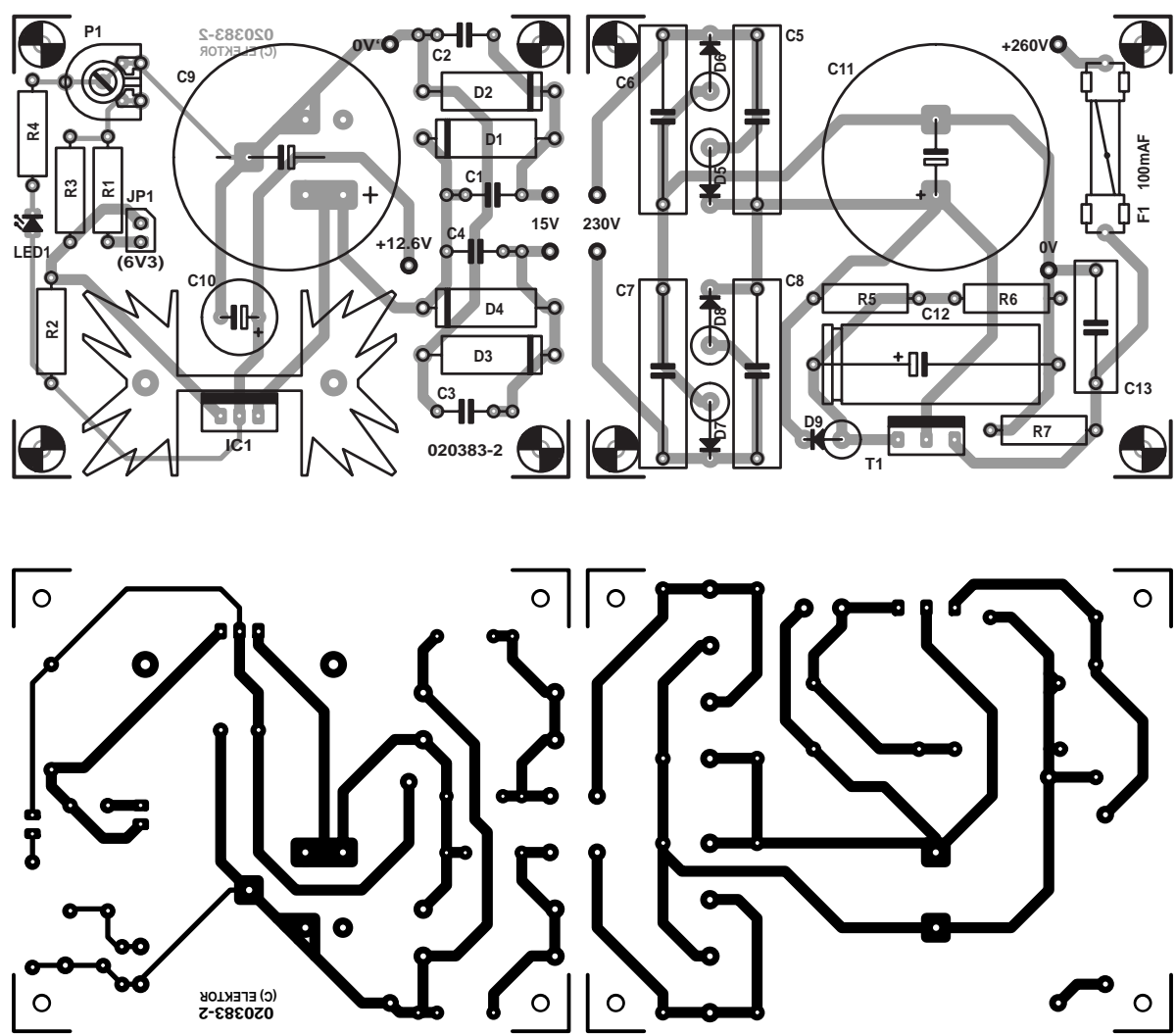

Figure 8. The two parts of the power supply circuit board must be sawn apart.

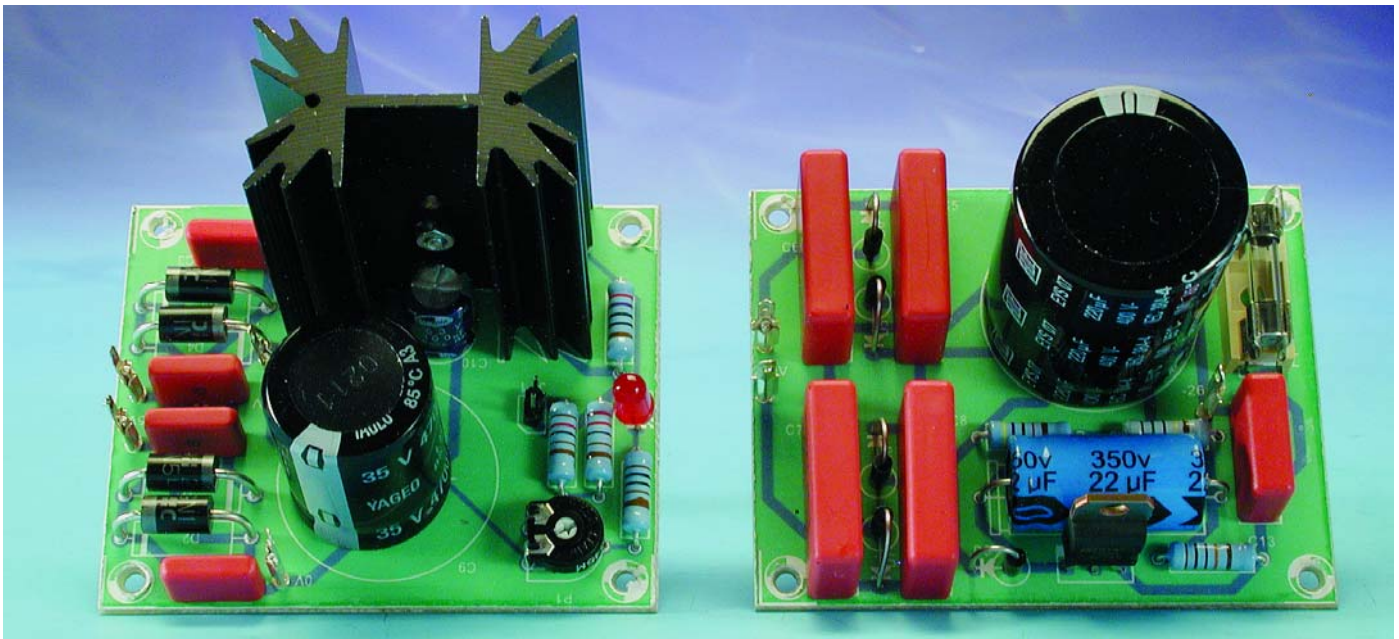

Figure 9. The fully assembled power supply boards. Pay attention to the polarity of the diodes!

boards. Part 2 of this article will include a wiring diagram showing how the screens of all the screened wiring should be connected in order to avoid ground loops. The rest of the wiring will also be described in detail in this diagram.

Power supply boards

Two printed circuit boards have been designed for the power supply. One is for the low-voltage portion, and the other is for the high-voltage portion. These two boards are supplied as a single board, so they must

first be sawn apart, since they will be fitted on opposite sides of the ‘transformer block’ (the two transformers stacked together).

Assembling the circuit boards is a simple job. PCB pins and push-on mating receptacles (sleeves) are used here as well for the connections. The electrolytic capacitor shown in the components list for position C9 has three terminals, but the circuit board can also accommodate a type with two terminals. Use heat conducting paste when fitting IC1 to the heat sink.

After inspecting the assembled circuit boards, it’s a good idea to temporarily mount them on a wooden board along with the transformers, so you can quickly check out the power supply boards. For safety, a test load consisting of a 230-V, 8-W lamp can be connected to high-voltage output. Without the lamp, the voltage on the output should be approximately 260 V, while with the lamp it will be a good deal lower. Be careful when measuring this voltage!

While you are checking out the power supply, you can also adjust the filament supply voltage to exactly 12.6 V.

Figure 9 shows what the fully assembled power supply boards should look like.

(020383-1)

COMPONENTS LIST

Power supply boards

Resistors:

R1 = 1kΩ
R2 = 270Ω
R3 = 2kΩ
R4 = 1kΩ
R5 = 47kΩ
R6 = 1MΩ
R7 = 100kΩ

P1 = 500Ω preset, horizontal, lead pitch 5/2.5mm or 5/10mm

All resistors: metal film 0.5-1W, e.g., Benschlag MBE-0414

Capacitors:

C1-C4 = 100nF 100V, lead pitch 10mm
C5-C8 = 100nF 630V, lead pitch 22.5mm
C9 = 4700µF 40V, radial, lead pitch 10mm or 12.5mm
C10 = 100µF 63V, radial, lead pitch 5mm
C11 = 220µF 400V, radial, lead pitch 10mm
C12 = 22µF 350 V, axial, 16x36 mm

C13 = 100nF 630V, lead pitch 22.5mm

Semiconductors:

D1-D4 = 1N5404
D5-D9 = 1N4007
IC1 = LM317
T1 = IRF740, BUZ61 or BUK455-400B ($V_{DS} \geq 400V$)
LED1 = LED, 5mm dia., red

Miscellaneous:

Tr1 = toroidal transformer 230V/2x15V, 1A, Amplimo type 11013 (www.amplimo.nl)
Tr2 = toroidal transformer 230 V/2 x 15 V, 0,5 A, Amplimo type 1013 (www.amplimo.nl)
J1 = 2-way PCB pinheader
Heat sink, R_{th} 5 K/W, e.g., Fischer type SK129/50,8/STS
PCB mount fuse holder with cap, 5x20mm, lead pitch 22.5mm
F1 = 100 mAF (fast acting) fuse
8 solder pins with mating sockets (sleeves)
PCB, order code **020383-2** (see Readers Services)

Next month, we will continue with the assembly and wiring of the preamplifier, as well as an enclosure. We’ll also have a close look at its specifications.

Valves at Low Plate Voltages

Interesting and surprising experiments with valves

by B. Kainka

Is it just nostalgia, or are valves really somehow better than transistors? Recently valves have been making something of a comeback in many areas. Using valves seems to involve a lot of effort, and in particular the high voltages frighten many people off. But there are dozens of valves lying about in many a cellar — so why not try something new with those old valves?

Valves are usually driven using an anode voltage of 250 V or more; practically never with an anode voltage below 100 V. For power amplifiers, in particular for radio transmitters, several kilovolts can be used. Such inconveniently high voltages naturally put many people off, as do the special transformers and high-voltage electrolytic capacitors that are needed. But things need not be like this. A series of experiments has shown that most of those valves nostalgically kept at the back of the cupboard will work at very low voltages. Of course, we are not talking about achieving the ultimate in power or amplification, but for simple applications — and a bit of fun — it fills the bill.

We will describe in this article how to build simple circuits using valves with a minimum of fuss. Operating at anode voltages of, for example, 12 V is not recommended by manufacturers and is not covered in any data sheet. So, if we are going to learn anything, we will need to experiment and make some measurements.

In order to forestall criticism from committed valve-lovers, we should say that the aim here is not to build the last word in hi-fi amplifiers or find the optimal operating point for some particular valve. We are more interested in gaining some experience with valves in a simple and safe way. There is a special satis-



faction in building a small circuit and making a simple working device. And it is not just about feeling the warm glow from the cathode: it is like going back in time to the early days of electronics, when the (relatively simple) technology was dominated by amateurs and everything was visible. Valves in their glass envelopes are certainly more 'transparent' than ICs in plastic packages.

Of course, we could do things 'properly', and use anode voltages of 250 V; but that would not exactly make for simple and relaxing experimentation on the bench. A chassis would be required and everything would have to be built carefully into a case. And we would always have to watch out for those dangerous voltages. None of this is a problem if we stick to low voltages.

Types of valve

The question frequently arises: 'are valves still being made?' The answer is yes. Out of the enormous range of valves that used to be available, a few are still around, being made by several manufacturers. As well as valves still used in radio transmitters there are a few types specially designed for hi-fi amplifiers. Output stage valves such as the EL84 (6BQ5) and EL34 (6CA7), and ECC81 (12AT7), ECC82 (12AU7) and ECC83 (12AX7) double triodes are readily obtainable today, albeit at rather higher prices than a few decades ago.

Other sources of unused valves are mail-order suppliers such as Chelmer Valve Co., who offer a particularly good stock of European, US and Russian valves at reasonable prices. Especially interesting are the numerous types of miniature valves, so-called 'battery valves', which are designed to run on low voltages.

However, we are not limited to using new valves. Devices salvaged from the cellar will generally be old radio or television valves. In the good old days radios and televisions that were beyond repair were often cannibalised for their valves. In televisions we generally find P-series valves, designed to have their heaters wired in series, with a heater current of 300 mA, as well as the ECC81 and ECC82 types mentioned above, and any number of EF80s (6BX6). From radios we can obtain interesting devices such as EL84s and EL95s (6DL5) in output amplifiers. The E-series devices require a heater voltage of 6.3 V. All these devices can be brought back to life, and can even be used at low anode voltages.

Indeed, there are so many different types of valve that we do not have space in this article to cover the technical details and socket pinouts for all of them. All the necessary information can, however, be readily found on the Internet. There are also sites that give example circuits and hobby projects alongside such data. Even the use of low anode voltages is mentioned here and there, and it is becoming something of a hobby in itself. So, for example, the hobby corner of the

author's website (www.b-kainka.de) includes example circuits from a 12 V headphone amplifier using two transmitter valves to an Audion-type receiver. There are also many links to similar projects.

The ECC81 (12AT7)

The ECC81 is readily available both new and second-hand. From the double triode series ECC81/ECC82/ECC83, which all have the same pinout, the ECC82 is also suitable, but the ECC83 has too low an anode current at low voltages. The ECC81 was originally intended for HF applications and sweep circuits in televisions and oscilloscopes. They are therefore capable of operation at high frequencies, and best performance is obtained with anode currents of between 5 mA and 10 mA. For HF applications the valve is often found in a cascode configuration, where the two triodes are in series and therefore share the available anode voltage. This is why the ECC81 has adequate anode current and transconductance at low voltages.

Once one has obtained a used valve, the first question is naturally whether it works or not. This does not require a complete circuit to be built: a couple of simple experiments can be carried out on the bench with the aid of crocodile clips. First a heater voltage must be applied. **Figure 1** shows the socket pinout of the ECC81. Almost all valves with a nine-pin 'noval' base have heater connections on pins 4 and 5. The ECC81, ECC82, and ECC83 are a bit special, however: the heater element has a centre tap on pin 9. This means that the valve can be used with a heater voltage of 12.6 V (with a current of 150 mA) or with a heater voltage of 6.3 V (at 300 mA). This is very convenient for our purposes, since we can use 12.6 V (12.0 V will also do!) for both the heater voltage and the anode voltage.

First connect the heater voltage of 12 V to pins 4 and 5. After about half a minute the cathode will start to glow. If no current flows, the valve is probably burnt out. This case is relatively rare. More frequently, the valve is not burnt out but rather badly aged and will have rather poor char-

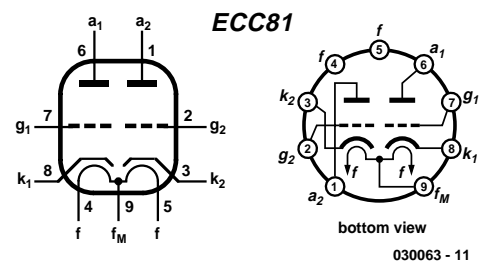

Figure 1. Pinout of the ECC81.

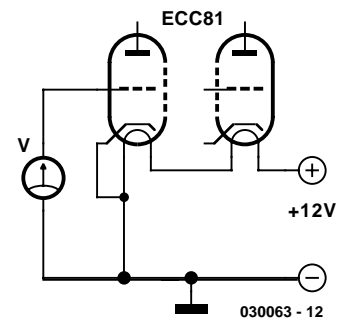

Figure 2. Measuring the negative charge on the grid.

acteristics. For simple experimental purposes, however, it will probably be perfectly usable.

The second thing to test is whether the vacuum in the valve is still hard. Connect a voltmeter between cathode and grid (see **Figure 2**). If all is well, a voltage of approximately -0.5 V should appear on the grid (assuming the voltmeter has an input resistance of 1 M Ω). This is already showing the effect of free electrons. The hot cathode ejects electrons into the free space around it, and some land on the grid, giving it a negative charge. If, instead of measuring the open-circuit voltage, the short-circuit current is measured, a value of around 20 μ A will be found.

This effect is used in many circuits to automatically create a negative grid voltage, including in the headphone amplifier described below.

Whether the vacuum is still hard can often be determined by inspection. The ECC81 has a silver-coloured speck at its end, called the 'getter flash'. When the valve is manufactured the air is pumped out of it through a glass tube and then it is sealed. In the end of the valve there is a ring-shaped groove which is filled with a metal having a low melting point. This metal is heated through the glass using a powerful HF magnetic field: this evaporates the metal onto the inner surface of the glass below. The result of this whole process is to permanently trap the last

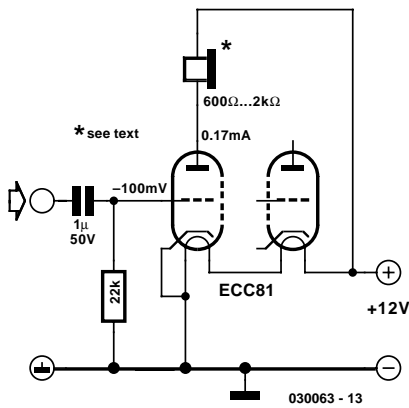

Figure 3. A simple headphone amplifier.

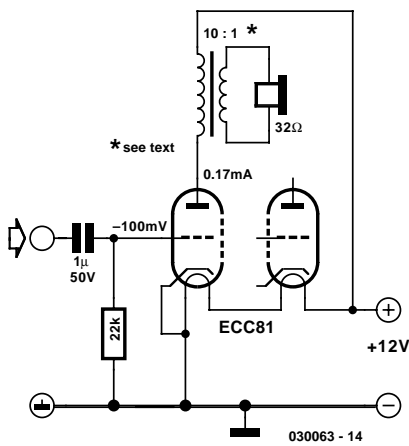

Figure 4. Using an output matching transformer.

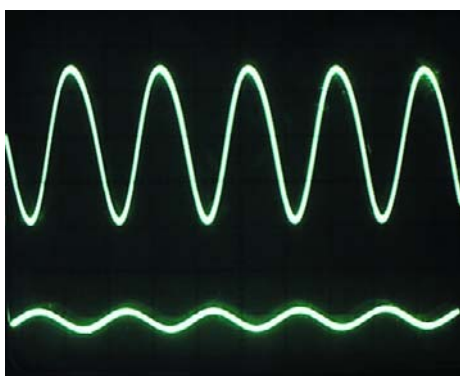

Figure 5. Input and output signal voltages displayed on an oscilloscope.

remaining gas molecules in the envelope. If, after years or even decades, the getter flash is still bright, then all is well; if it is white or grey, it means that air has leaked in and the getter metal has oxidised.

Headphone amplifier

If the cathode glows, a grid current can be measured, and the getter metal is still bright, the valve is in good order and you can use it to build this simple headphone amplifier. The circuit is presented here in two variations. The first circuit, in **Figure 3**, requires just two components per channel in addition to the valve and headphones.

The anode current of 0.17 mA measured experimentally in a used valve is relatively low. In specially-designed low-voltage valves the current was somewhat higher: for comparison, the low-voltage ECC86 (6GM8 or CV5394) has an anode current of 1 mA in this circuit. Note that if by chance you do have an ECC86 available, it cannot be fitted directly in the same socket: it has no centre tap on the heater, and so requires a voltage of 6.3 V between pins 4 and 5.

The first simple amplifier circuit works perfectly well with high-impedance (600 Ω or 2000 Ω) headphones. However, it is not good practice to maintain a DC current through headphones, although there is no danger of overloading the system, since the anode current is very low. The sound quality can suffer, however, at slightly increased currents and, furthermore, high-impedance headphones are relatively rare. If we want to use ordinary headphones from a personal stereo, having an impedance of 32 Ω, the output level will be very low. The problem is that the impedances are severely mismatched: the impedance of the valve output is of the order of kilohms. An impedance converter will do the job: for example, we can use a small 230 V/24 V 1.8 VA mains transformer. This has a voltage ratio of about 10:1. The transformer we used in our experimental circuit (**Figure 4**) had a primary with a DC resistance of 2.5 kΩ and a secondary with a DC resistance of 100 Ω. Using a larger transformer has the advantages of lower loss and hence higher volume. With a voltage ratio of 10:1 the effective headphone impedance is increased by a factor of 100. If the headphones have an impedance of 32 Ω, the valve sees an impedance of 3.2 kΩ, which will give considerably

better results. The theoretically optimal operating resistance for the valve is in the region of U_a/I_a , which, at an anode current of only 0.17 mA is around 70 kΩ. The exact impedance is not critical in this application, and so even headphones with an impedance of 600 Ω can equally well be used in conjunction with the same transformer. The impedance seen by the valve would then be about 60 kΩ, practically ideal for the given anode current.

Characteristic curves

The oscilloscope traces in **Figure 5** show that the valve does indeed work with a low anode voltage. The voltage gain of about 8 was obtained at high impedance using an impedance converter and 600 Ω headphones. In general, the following relation holds for voltage gain:

$$V = S \times R_a$$

where V is the voltage gain, S the transconductance and R_a the output resistance. Given that the output resistance is 60 kΩ, the transconductance of the valve must be 0.13 mA/V. This broadly fits in with the general observation that the transconductance of a valve at any operating point is approximately equal to the anode current divided by 1 V. The official data sheet for the ECC81 gives, for example, an anode current I_a of 3.0 mA at $U_a = 100$ V and $U_g = -1$ V, with a transconductance of 3.75 mA/V. This comparison also shows a disproportionate fall in current and transconductance when operated at an anode voltage of only 12 V. This means that for serious applications the anode voltage should be as high as possible. An acceptable compromise between safety and gain might be around 24 V.

In order to learn to understand the properties of the valve at low anode voltages, we need to study its characteristic curves. Manufacturers' data sheets are of no help here, since they do not cover operation at such low voltages (it was apparently at that time not of any interest). For the same reason ordinary simulation programs do not give realistic results.

To measure real data all that is

needed is to apply a variable grid voltage and measure the anode current (Figure 6). The measured characteristic curve shown in Figure 7 indicates a rise in transconductance with anode current at negative grid voltages. When the grid voltage is positive, the transconductance stops rising, and in the region above +1 V, it starts to fall again. At the same time the grid current rises and, above about $U_g = +0.5$ V, can exceed the anode current. It is worth plotting the characteristic curve, in particular for used valves, in order to determine an optimal operating point.

Positive Grid

If it is desired to build the headphone amplifier as a permanent device, rather than merely experiment with it, it might be found that the output volume can be too low in some conditions, especially when operating from a 12 V supply. What is needed is to give the electrons a bit more energy by applying a slightly positive grid bias voltage. Old hands will now protest vehemently that this implies that a grid current will flow, resulting in severe distortion. That is true in principle, but it is not a problem if the grid drive has a relatively low impedance. Previously, in the golden era of valves, the grid had to be driven from a high impedance source, since the output of the previous stage necessarily had a high impedance. Today we can use the low-impedance headphone output of a small

CD player, and a little grid current no longer matters.

In the circuit in Figure 8 a grid current of the same order of magnitude as the anode current is set up. The anode current and the achievable output drive are now three times higher than with a grid voltage U_g of -0.1 V. This gives almost ten times the output power, which should be adequate for many uses. The grid voltage is set at $+0.5$ V and the anode current is 0.5 mA. We are therefore in the region of the characteristic curve where the transconductance is constant, and so distortion should be low. The sound of this simple amplifier is indeed very good, even though it might not be perfect from a purely technical point of view. The inevitable distortions introduced by a valve stage, especially when driven hard, are however generally not regarded as unpleasant.

Perhaps you have noticed that in this circuit the valve can be simply replaced by two NPN transistors. Instead of a grid current we have a base current, instead of an anode current, a collector current. Of course, the transistors do not need a heater: such is the nature of progress. Which circuit sounds better is a matter of taste: try it for yourself. Most people come to the conclusion that the valve sounds better. It is worth putting up with the fact that the power consumed by the heater is orders of magnitude higher than the output power of the amplifier: in return one can enjoy the cosy glow of the cathode and

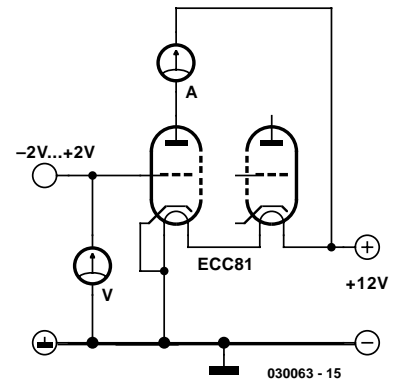

Figure 6. Plotting the characteristic curve.

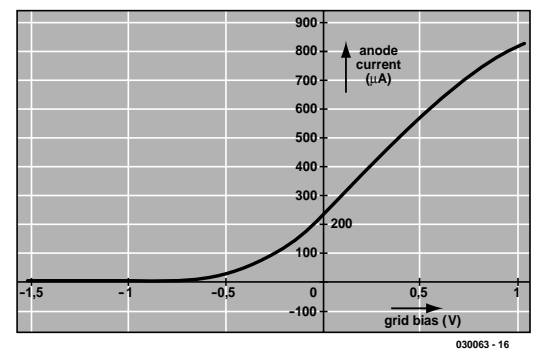

Figure 7. Characteristic curve for an ECC81 at $U_a = 12$ V.

the opportunity to warm ones hands (carefully!) on the valve.

More power

Readers with a lust for power who are tempted to try to go a step further and drive the headphone amplifier to the edge of distortion might prefer to wait for the second article in this series. We will be looking at real power valves such as the EL84, EL95, ECL80 and ECL86, as well as a PL504, which we will be using in an amplifier with a loudspeaker output, and at an anode voltage of only 27 V. We will also describe several miniature Russian 'battery' valves, which not only work with low anode voltages, but which also dissipate much less heater power.

(030063-1)

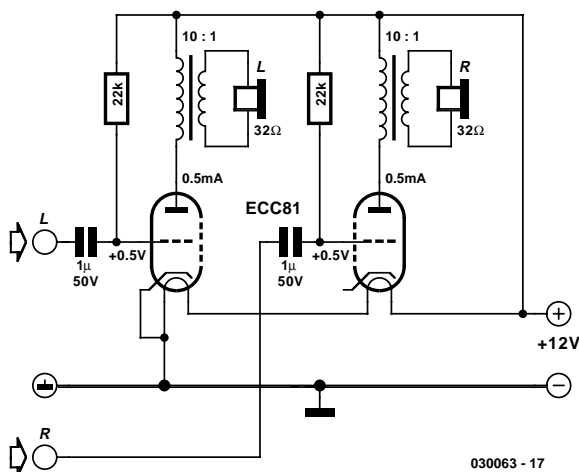

Figure 8. Stereo amplifier with positive grid bias.

Links

Hobby projects and experiments:
<http://www.b-kainka.de/>
 Chelmer Valve Company:
<http://www.chelmervalve.com>

Polyphonic Doorbell

Several tunes from a PIC 16F84

Design by D. Manier

Music has been defined as ‘the art of combining sounds in a manner that is agreeable to the ear’. We thought would be a nice idea to entrust this delicate task to the best-known microcontroller in the Microchip stable, the PIC 16F84.

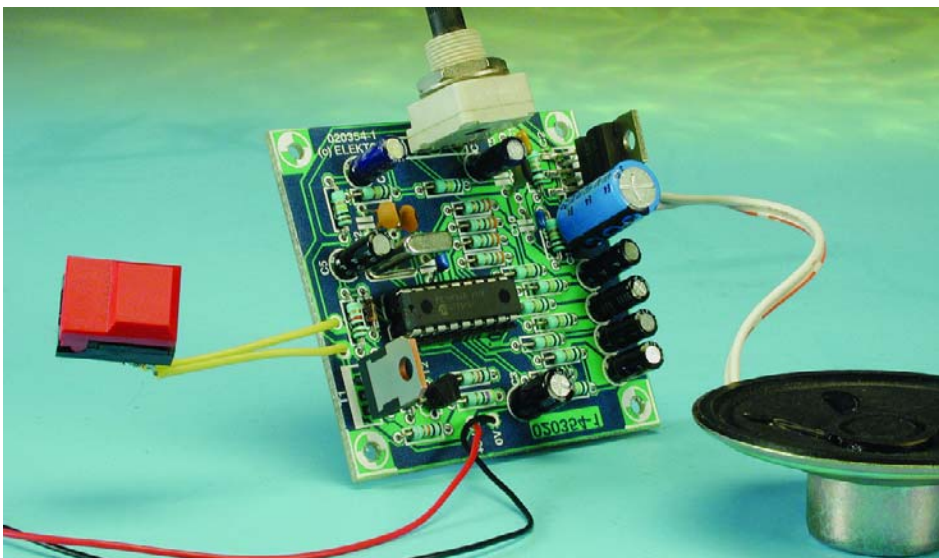

This circuit, which can serve as a musical doorbell or music generator, is built around a microcontroller, and it can be configured by the user. You'll be amazed by its virtuosity and the quality of the (polyphonic) sound it produces.

As a doorbell, this circuit has several attractive features:

- very good sound
- eight different tunes
- zero current when quiescent
- customisable tunes
- reasonable construction cost

The concept

Our electronic musician must perform the following tasks:

1. Switch on the power when the doorbell is pressed, and reduce the current consumption to zero at the end of the tune.
2. Generate musical notes (up to four at the same time), generate envelopes for these notes and mix them together, all based on a short tune stored in memory.
3. Store the number of the most recently played tune in memory and then switch to the next tune. The tune number is stored in EEPROM, so the information is retained even in the absence of power.
4. Amplify the signal for output to a loudspeaker.

The first three tasks (power management, music generation and data storage) are entrusted to the PIC 16F84. For amplification, we use a special audio IC, the TDA2006. The volume of the sound can be set using a potentiometer. The impedance of the connected loudspeaker may lie between 4 and 8 ohms.

Some basic terms

First we need to describe a few basic musical terms.

When a musician plays a piece of music, he first reads the score. The score describes the notes to be played and their respective durations.

The location of a note on a musical staff (the well known set of five parallel lines) determines the name and the pitch of the note. The four notes shown in **Figure 1** are (from left to right) an A, a G, a C and an F.

The form of the note (open or filled, with or without a tail, with or without a flag) determines the duration of the note. In Figure 1, the notes are, in succession, a quarter note, an eighth note, a full note and a half note. A full note lasts twice as long as a half note, a half note lasts twice as long as a quarter note, and a quarter note lasts twice as long as an eighth note.

Naturally, there are notes with other durations and other elements of musical notation, but this condensed summary is all we need for

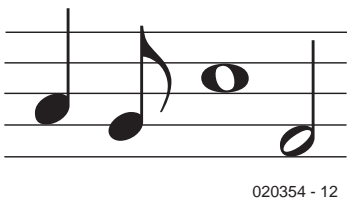

020354 - 12

Figure 1. A staff with the four most commonly used types of notes.

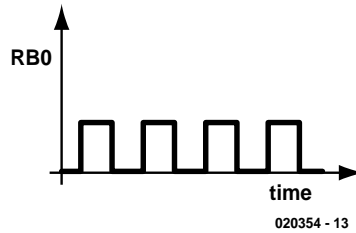

020354 - 13

Figure 2. A square-wave signal as found on ports RB0–RB3.

the purposes of this project.

A chromatic scale consists of twelve notes (*C, C#, D, D#, E, E#, F, F#, G, G#, A, A#* and *B*). The frequencies of these notes are generated as a mathematical series based on the twelfth root of 2 (or 1.05962...).

The notes for the various melodies are stored in the PIC IC in the form of tables holding the pitch and associated duration of each note.

To generate these notes, the program uses down-counters that are preloaded with the values corresponding to the notes we wish to hear. Each time a counter reaches zero, the state of an output port (RB0–RB3 for the four tones) is inverted, thereby generating a square wave as illustrated in **Figure 2**.

The circuit

The block diagram of the doorbell is shown in **Figure 3**. The circuit con-

sists of four subassemblies: the power supply, the 'brains' and memory (in the form of the PIC 16F84, which provides all of the active functions), a mixer and an audio amplifier to drive the speaker that reproduces the tune.

Power supply

Our 'musician' takes his cue from the doorbell pushbutton S1 (refer to the schematic diagram in **Figure 6**). When it is pressed, transistor T2 starts to conduct, thus driving T1 into conduction. When T1 is conducting, a voltage of 5.1 V is present across Zener diode D1. This voltage, filtered by C4 and C5, powers the PIC 16F84. The voltage on the collector of transistor T1 also goes to the audio amplifier (IC2).

When the PIC starts up, output RA3 goes high and a voltage of 5 V is applied to the base of T2 via resistor R6. Once this happens, the pushbutton can be released. At the end of

the tune, the PIC sets output RA3 low again, causing T1 and T2 to cut off and switch off power to the circuit (if the pushbutton has already been released).

Note generator

The program in the PIC can generate four notes at the same time, which is called **polyphony**. In order to obtain the maximum possible speed, the notes are generated in the main program routine.

The PIC timer sets the tempo for playing the tune. For each note to be played, a counter loaded with a value corresponding to the duration of a note is decremented each time an interrupt occurs. When this counter reaches zero, the program continues with the following note and its associated duration.

The signals produced in this manner are square waves, which are rich in harmonics. This increases their sonic range, but in order to make the sound of our doorbell more pleasing to the ear, we have added a function called 'envelope generation'.

Envelope generator

The envelope generator works according to the principle shown in **Figure 4**. At the start of each note, a capacitor (C6–C9) is very quickly charged via a low-value resistor (330 Ω) connected to a port configured as an output (RB4–RB7). After the capacitor has been charged, the port is immediately reconfigured as an input, which causes it to have a high impedance, so the capacitor cannot discharge via the port.

The note generators (RB0–RB3) are connected to the envelope generators via relatively high-value pull-up resistors (100 kΩ). In order to obtain the curve shown in **Figure 4**, ports RB0–RB3 would have to be open-collector outputs (type RA4), but this is not the case. In order to obtain the desired mode of operation, ports RB0–RB3 are configured as follows:

- as outputs for a '0' value
- as inputs for a '1' value

A port configured as an output and having a '0' value is essentially equivalent to an open-collector output generating a low level ('0'). The same port configured as an input has a high impedance, and it is pulled high ('1' value) by the pull-up resistor.

The envelope generator capacitors discharge via these relatively high-value pull-up resistors. This yields a time constant of approximately 0.3 s. The resulting waveforms on RB0–RB3 this have the shape shown in **Figure 5**. This waveform, with a brusque attack and an exponential decay, gives the generated notes a timbre resembling that of a piano (with apologies to purists!).

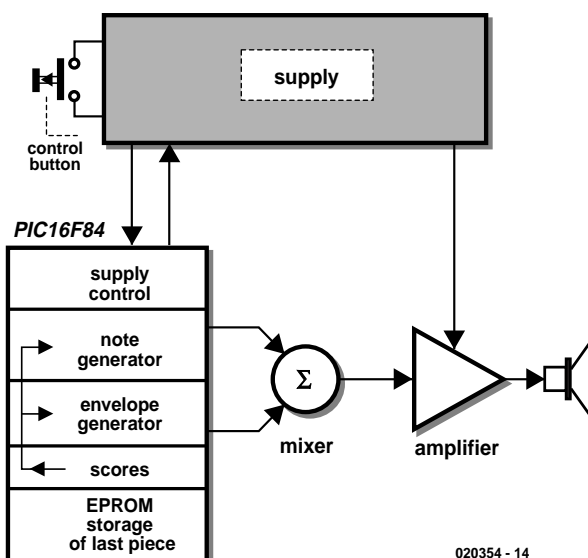

020354 - 14

Figure 3. Block diagram of the polyphonic doorbell.

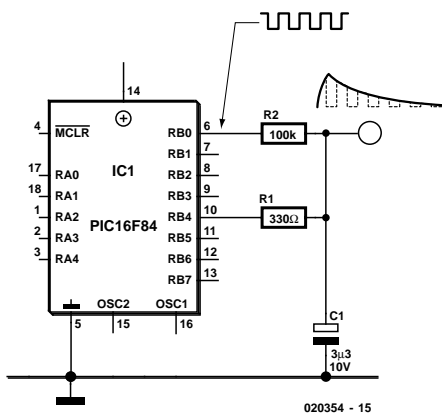

Figure 4. Working principle of the envelope generator.

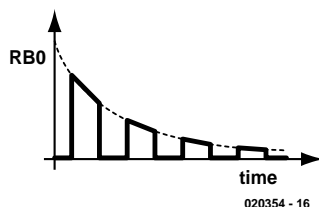

Figure 5. The final signal before the four notes are mixed.

The signals at the four note outputs (RB0–RB3) are mixed using resistors R11–R14. The resulting signal is taken from resistor

R19. This combined signal is passed to the audio amplifier via capacitor C10. The gain of the amplifier can be adjusted using potentiometer P1. P1 should be to provide maximum non-distorted output power. To increase the audio power level, the supply voltage for this stage can be increased to as much as 13.5 V (three 4.5-V batteries in series).

If for some reason you want to be able to stop a tune before it has finished playing, you can connect a pushbutton switch across R3.

Construction

If you use the printed circuit board shown in Figure 7, building the circuit is child's play. Start with the lowest components, as usual. After this, fit the 'taller' components, such as T1, IC2 and P1. If you use a socket for IC1, you can later add new tunes if you wish. If you have no intention of ever changing the repertoire of the doorbell, simply solder IC1 to the circuit board.

Software

Now that you've learned something about the theoretical and practical aspects of the doorbell circuit, it may

be interesting to look at the software, particularly if you can program PICs.

The software is available on diskette from Readers Services (order number 020354-11), or you can download it free of charge from the *Elektor Electronics* website. It was generated using Microchip's MPLAB environment. The main routine of the program, *carillon.asm*, uses three subroutines: an initialisation routine, a 'play' routine and an interrupt routine, which calls the *morceau* ('piece') routine.

The *def84.asm* file contains the Special File Registers (SFRs) and declarations, while the *macro.asm* file contains macros that allow a 'pseudo-Pascal' program structure to be used (IF ... REPEAT ... BEGIN ... END). Finally, the *morceau.asm* file contains the musical pieces (scores) and the down-counter values for the note generators.

Figure 8 shows a high-level flow chart that describes the operation of the program. When pushbutton switch S1 is pressed, power is applied to the circuit. The initialisation routine first configures the various ports as inputs or outputs, configures the various timer parameters related to interrupts, and then sets

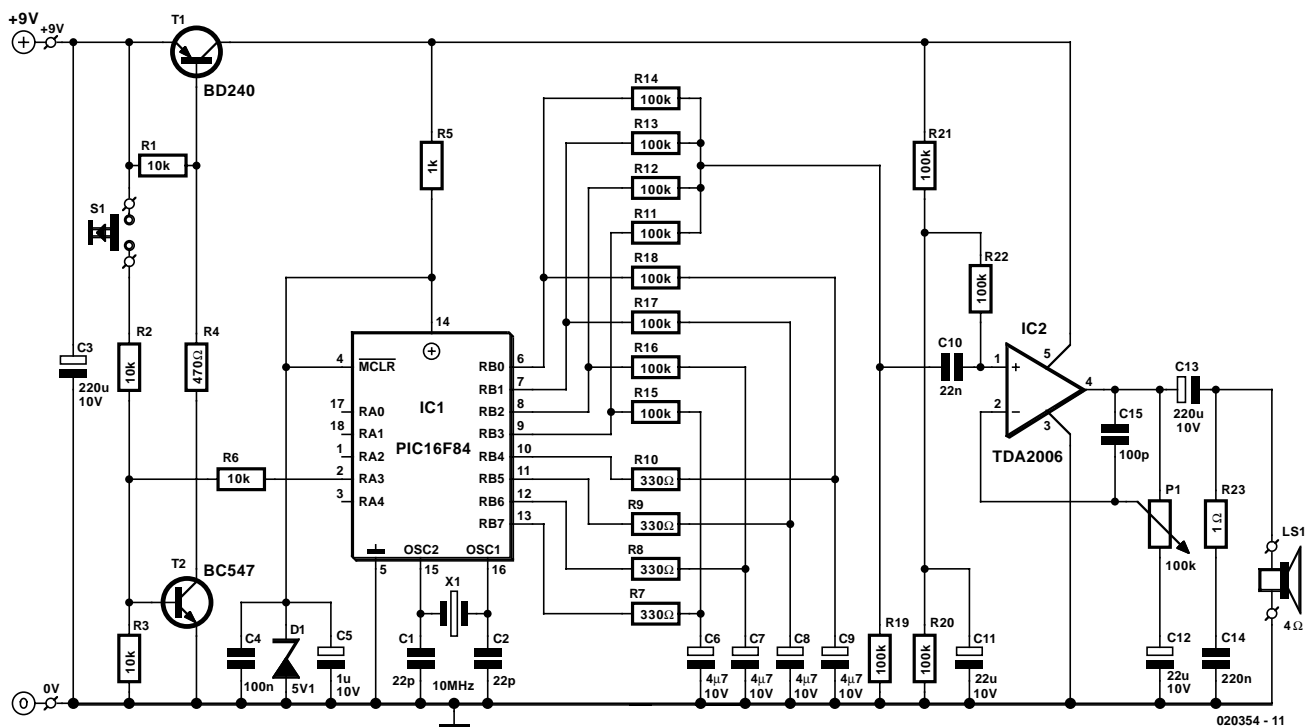

Figure 6. The electronics consists of only two ICs surrounded by a handful of passive components.

COMPONENTS LIST

Resistors:

- R1,R2,R3,R6 = 10kΩ
- R4 = 470Ω
- R5 = 1kΩ
- R7-10 = 330Ω
- R11-R22 = 100kΩ
- R23 = 1Ω
- P1 = 100kΩ logarithmic potentiometer

Capacitors:

- C1,C2 = 22pF
- C3 = 220μF 10V radial
- C4 = 100nF
- C5 = 1μF 10V radial
- C6-C9 = 4μF7 10V radial
- C10 = 22nF
- C11,C12 = 22μF 10V radial

- C13 = 220μF 10V radial
- C14 = 220nF
- C15 = 100pF

Semiconductors:

- D1 = zener diode 5V1 500mW
- IC1 = PIC16F84A-10/P (programmed, order code **020354-41**)
- IC2 = TDA2006 (Philips)
- T1 = BD240
- T2 = BC547

Miscellaneous:

- LS1 = 4Ω loudspeaker
- S1 = pushbutton, 1 make contact
- X1 = 10MHz quartz crystal
- 9V battery (6F22) with clip-on leads
- PCB available from the PCBShop Disk, all project software, order code **020354-11** or Free Download

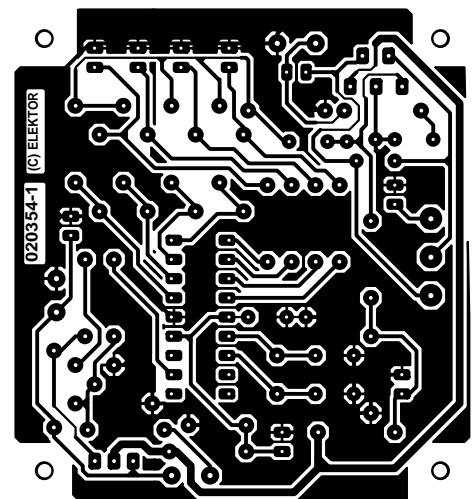
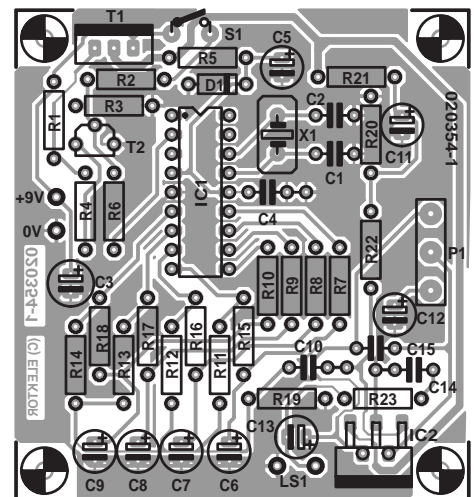

Figure 7. Copper layout and component layout of the printed circuit board for the musical doorbell.

reaches zero, the mask is used to individually configure ports RB0–RB3 as outputs with a '0' level or inputs with a high impedance, and the counter is reloaded with the value corresponding to the note to be generated. At the end of the routine, the mask is applied to the Port B direction register using an XOR function, which causes the affected outputs to be inverted in order to generate a square-wave signal.

The interrupt routine becomes active each time the timer value changes from '0xFF' to '0x00'. In this routine, the timer is reloaded with the vitesse (tempo) value and the duration down-counter is decremented. If the duration down-counter reaches zero, the morceau routine is called. In addition, ports RB4–RB7, which correspond to the envelope generators, are configured as inputs (high impedance).

The morceau routine first configures mask1,

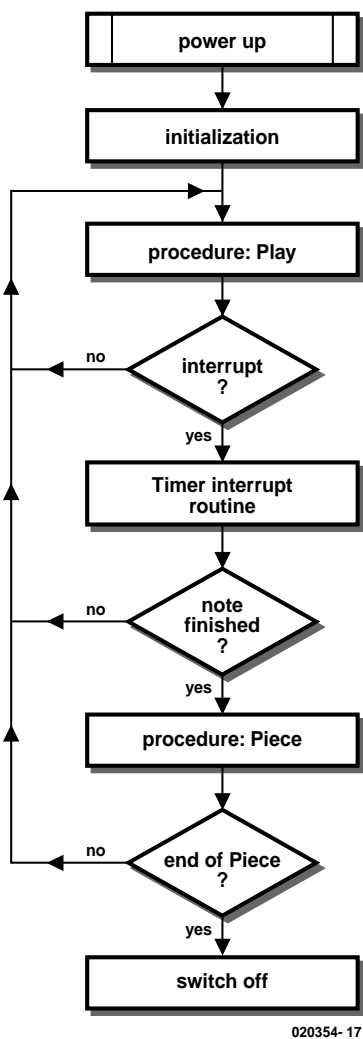

Figure 8. High-level flow chart

RA3 to '1' so that transistor T2 is held in a conducting state to provide power to the circuit.

Each time the initialisation routine is called, it reads the number of the last piece of music that was played (NUM0) from EEPROM address 0x00 and the complement of this number from address 0x01. If NUM0 and its complement do not match, something went wrong the last time these two values were stored. In this case, NUM0 is reset to '0x00' and its complement is reset to '0xFF', and these values are then stored in the EEPROM. If NUM0 and its complement do match (e.g., '0x02' and '0xFD'), the value of is NUM0 incremented (and if the result is greater than the largest possible number, it is set to zero). The new value and its complement are then stored for the next time.

The final action of the initialisation routine is to re-enable the interrupt timer.

The main routine then calls the play routine. This is the most important routine of the program, since it must run at the maximum possible speed, so its instructions are optimised for this purpose.

At the beginning of the play routine, interrupts are globally enabled to allow the interrupt timer to function, and the mask is set to '0'. The four down-counters are decremented each time the routine is executed. Each time a counter

Free Downloads

PIC microcontroller software.

File number: 020354-I I.zip

PCB layout in PDF format.

File number: 020354-I zip

www.elektor-electronics.co.uk/dl/dl.htm,

select month of publication.

which is used to drive outputs RB4–RB7 in order to charge the envelope generator capacitors. It then queries the `morceau0` table, which represents the beginning of the musical score. Pointers `ptrmorceaul` and `ptrmorceauh`, which are calculated by the initialisation routine, allow the `morceau` routine to jump to the start of the desired musical piece and retrieve the first four notes to be played, along with their durations and adjuncts. An adjunct can hold a tempo value in order to control how fast the music is played (this value is used to reload the timer), or it can hold the value 'fin' (end) to mark the end of the tune. In the latter case, output RA3 is reset to '0' to switch off power to the circuit.

Conclusion

There are numerous possible applications for this circuit. Besides being used as a musical doorbell, it can also be used in a music box for children, a musical jewellery box, as an 'on hold' melody generator for the telephone, etc.

If you want to modify the tunes programmed into the PIC, you should bear in mind that you will have to redo the process of assembling and compiling the code needed to generate the hex file to be stored in the microcontroller. The development environment used by the author (Microchip MPLAB version 5.70) can be downloaded free of charge from Microchip at <http://www.microchip.com/1010/pline/tools/picmicro/devenv/mplabi/mplab5x/index.htm>. (note that version 6.13 requires a different project format). The procedure for editing a piece of music is simple: first load the project (taking care that all of the

necessary files are present in the ... \MPLAB directory), then assemble and compile the program using the 'Build All' command. This will produce a hex file that can be transferred to the PIC using a suitable programmer.

(020354-1)

Contents of diskette/file 020354-II

Assembler files:

carillon.asm

def84.asm

morceau.asm

macro84.asm

Hex file:

carillon.hex

Project file:

carillon.pjt

Nintendo-64 Joystick on the PC

An update for the latest games

By K. Schuster

A number of readers kindly informed us that not all new games released for the PC work smoothly with the software we supplied for the 'PC Interface for Nintendo Joystick' project published in the February 2000 issue. The software update described here solves the main problem of jerky movements (or none at all).

100% incremental control
66% incremental control
33% incremental control
A-B exchange

L button and C button Up (default)
L button and C button Right
L button and C button Down
L button and C button Left

Correct operation of the Nintendo-64 joystick in combination with PC games is dependent on the synchronisation of the microcontroller with the rate of the scanning pulses that appear at the PC's joystick port. In order to start timely, the two instructions `jnb JOYAX, *` and `jnb JOYAY, *` are essential in the main loop. The previous version of the software only monitored the JOYAX signal, which caused timing routines to be started too early resulting in slightly jerky movements on the screen (for example, of a crosswire or a game character). In relation to the same problem, the two delays `jb JOYAX, *` and `jb JOYAY, *` have been inserted to get a better defined flag when the scanning routine starts. Once the start of a scanning routing has been positively identified, the joystick lines JOYAX,

JOYAY, JOYBX and JOYBY are made logic Low. This prevents the charging of the capacitor networks inside the PC. Next, the program executes the routine `servicetime` which interrogates the Nintendo-64 controller, calculates the values for Joystick A and Joystick B and, finally, copies the status of the joystick button to the PC. As opposed to the old software, the measured analogue values are directly processed as 8-bit values rather than converted into signed 16-bit values (which is time

consuming). The accuracy is not affected because only 8-bit values are available from the controller. To make sure that the service routine has a uniform length, a timer is arranged to run in parallel with it, and the timer's timeout flag is monitored once the service routine is finished.

In the next subroutine, called `joytime`, the individual joyport lines are successively made logic High depending on the joystick position. The timing capacitors in the monostable multivibrators contained in the PC's joystick interface are then allowed to charge, resulting in 'fake' analogue resistance values. Because `joytime` is reduced to a simple wait loop without interrupts, the 16-bit conversion has been removed. Another change is the small delay after `joytime`, which allows the capacitor networks to charge completely.

When the new software is used, the controller needs to be software-calibrated again. How this is done is explained in the February 2000 article, which also discusses the operation of the circuit and the PC game port.

Another change affects the three-stage incremental control. In order to set the incremental rate of the control stick, it is no longer sufficient to press the L key on the controller. A new feature is the option to interchange the analogue unit and the control stick in software. This however requires a re-calibration of the joystick. The button allocation is not affected by the swap action.

(020288-11)

For switchover the following sequence is required:

1. keep L button pressed
2. keep desired C button pressed
3. Release L button
4. release C button

Sequence during scan cycle:

PC joystick lines	N64_2_PC joystick lines
High: from previous cycle	waits for Low
Low: discharge capacitors	waits for High
High: charge capacitors	Low: prevent capacitors charging
Measure charging time	Service time 250 μ s, fetch values from controller, process, output switch status
Measure charging time	joytime approx. 10-1285 μ s, then pull all lines High and start charging capacitors
Measure charging time	Consolidation time approx. 20 μ s
Process measured times	

Free Downloads

Updated microcontroller software.

File number: **020288-11.zip**

www.elektor-electronics.co.uk/dl/dl.htm, select month of publication.

More Light!

Practical high-power LEDs

By Professor M. Oßmann

In recent years the LED has seen many improvements so that we see them fitted in more and more situations where filament lamps were traditionally used. They have many advantages and their excellent reliability is often an important consideration.

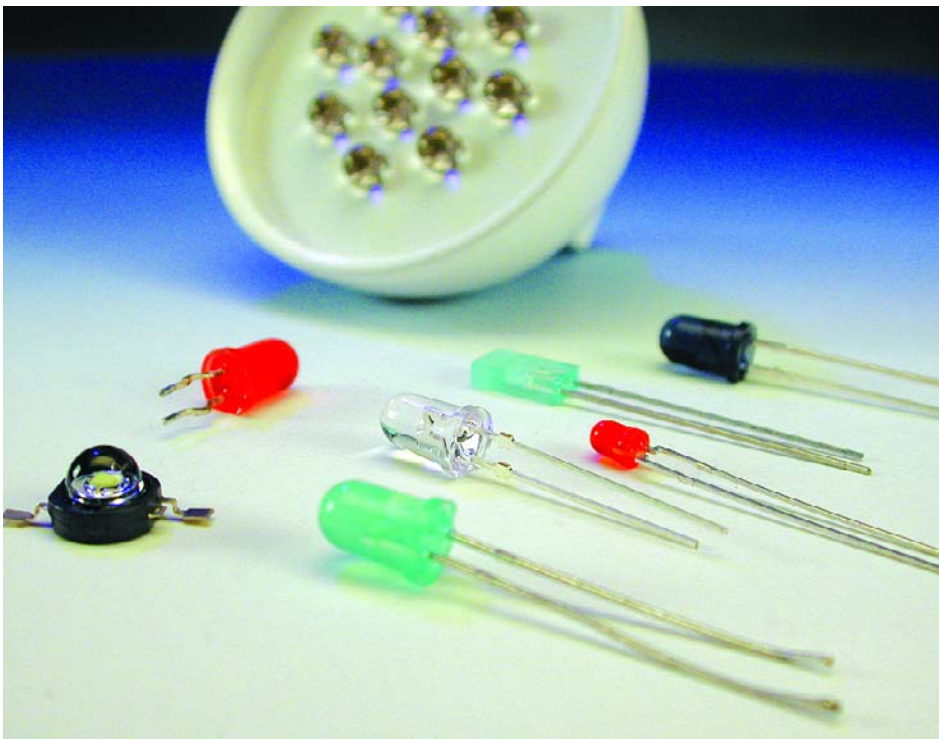

LED technology has come on leaps and bounds in the last few years and recently some of the higher output devices have become available commercially. Component supplier Conrad Electronics (www.int.conradcom.de) kindly donated samples for use in producing this article.

Electronic engineers are not necessarily lighting specialists so this article sets out to fill in some of the technical background and also

explore a couple of simple circuits to drive a 1-watt high power LED.

Lumens or watts ?

In the electrical world we are familiar with the watt as a measurement of power. Transmitters or IR lasers for example, all have their outputs defined in watts. The equivalent

'power' of a light source is expressed in lumens. The lumen (lm) is a photometric unit for the luminous flux from a light source. The term photometric indicates that it takes into account the spectral response of the human eye and so gives an indication of how bright the source will be perceived. **Figure 1** shows the (day-light adapted) relative spectral luminous efficiency of the light wavelength to stimulate the eye (also known as the V-lambda curve). The eye is most sensitive to light with a wavelength of 555 nm (giving a relative efficiency of 1 on the curve). A monochromatic light source emitting at this frequency with a radiant flux of 1 W is equivalent to 683 Lumen. If we could keep the same output power but change the frequency of the light to 650 nm (red) the lumen calculation now becomes: $683 \times 0.107 = 73$ Lumen because at this frequency the relative efficiency has fallen to 0.107.

Infrared or ultraviolet light sources emit their energy at a frequency outside the eye response curve so the lumen value will be zero. The luminous flux is a measure of all the light emitted from the source irrespective of direction.

Lamps are also classified in terms of their luminous performance or efficacy. This parameter indicates how

much light is produced for how much electrical energy consumed and is expressed in Lumens per watt (lm/W). This calculation always takes into account the power consumed by the complete lighting unit including electronic ballasts etc that are necessary for some types of lighting.

Table 1 shows a comparison of some common lamps. It is interesting to see the spread of figures for different types of lamp technology. The low-pressure sodium lamp holds the record for the greatest efficacy and its unflattering yellow light is a

Candela

Take a look at any LED data sheet and you will soon come across the expression Candela (cd) rather than luminous flux when the light output of the device is quoted. The candela is the unit defining the luminous intensity from a small light source in a particular direction. A 1 cd light source emits 1 lm per steradian in all directions. A steradian is defined as the solid angle that has its vertex in the centre of a sphere (at the light source) so that 1 steradian has a projected area of 1 m² at a distance of 1 m. So:

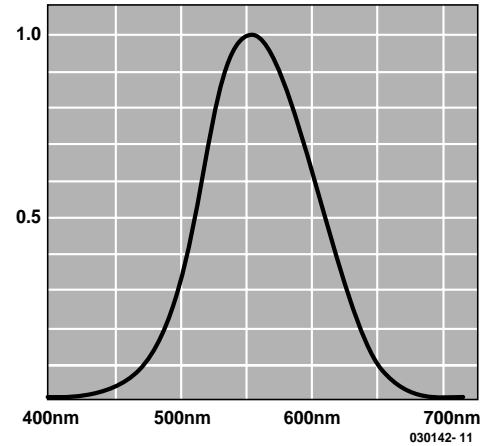

Figure 1. V-Lambda curve.

Table 1. Characteristics of common light sources.

Light source	Electrical energy (Watt)	Luminous flux (Lumen)	Luminous intensity (Candela)	Efficacy (lm/W)
Filament lamp	75	900	–	12
Fluorescent lamp	58	5400	–	90
Sodium low pressure	130	26000	–	200
Hg high pressure	1000	58000	–	58
Halogen 12 Volt	65	1700	–	26
Halogen reflector 10° beam	50	–	12500	–
Halogen reflector 60° beam	50	–	1100	–
LUXEON LED	1	18	–	18
NICHIA LED 20° beam	0.08	–	6.4	

familiar sight in high streets up and down the UK. White light sources will always have lower efficacies because the energy is spread throughout the visible spectrum.

Luminous intensity = Luminous flux per steradian
The luminous intensity parameter is usually given for directional light sources like halogen lamps with

built-in reflectors and also many LEDs. Along with this parameter it is also usual to specify the beam angle. The beam edges are where the luminous intensity has fallen to one half of the peak value. Lasers have an extremely

Table 2. Beam angle to solid angle equivalence.

Beam angle (degrees)	Solid angle (Steradian)
360.0	12.566 (4·π)
180.0	6.283 (2·π)
60.0	0.842
40.0	0.379
38.0	0.342
35.0	0.291
30.0	0.214
25.0	0.149
24.0	0.137
20.0	0.095
15.0	0.054
10.0	0.024



Figure 2. Various 1 W LEDs from Luxeon.

Table 3. Osram Decostar 51 reflector lamps.

Beam angle (degrees)	Luminous intensity (cd)	Luminous flux (lm, calculated)	Efficacy (lm/W, calculated)
10.0	9100.00	217.576	6.22
24.0	3100.00	425.638	12.16
38.0	1500.00	513.475	14.67
60.0	700.00	589.251	16.84

Table 4. Nichia white LEDs.

Beam angle (degrees)	Luminous intensity (cd)	Luminous flux (lm, calculated)	Efficacy (lm/W, calculated)
20.0	6.40	0.611	7.64
50.0	1.80	1.060	13.25
70.0	0.48	0.545	6.82

high luminous intensity because the beam angle is so small. **Table 2** gives the correspondence between the beam angle in degrees and the equivalent solid angle or steradian.

It is not easy to make simple comparisons between different light sources when sometimes the luminous intensity and other times the luminous flux is quoted and it is also important to consider the spectral content of the light. We have probably had enough definitions to chew on so a few examples may help to get more of a feel for the terminology:

Example 1: Cycle lamp

The lamp consumes 3 W of electrical power and produces a luminous flux of approximately 30 lm. Giving a luminous efficacy of approximately 10 lm/W. when used as an

isotropic light source (viewing angle 360° or 4·π steradians) the luminous intensity is about 2.4 Candela. Fitted with a reflector the luminous intensity measured in the centre of the beam will be about 250 Candela!

Example 2: Low voltage halogen lamp

An Osram Halostar lamp (isotropic source, no reflector, type 64432 IRC) consumes 35 W electrical power, producing a luminous flux of 900 Lumen. This lamp achieves an efficacy of 26 lm/W, which is relatively good for a halogen lamp.

Example 3: Low voltage halogen reflector lamp

Lamps with built-in reflectors are rated by their light output and beam angle. The beam angle is a useful parameter for calculating the light spread in spot lighting applications. Many manufacturers produce lighting units using lamps of the same power fitted to reflectors with different beam angles. Table 3 shows specifications of the Osram Decostar 51 (51 mm reflector diameter) 35 W, 12 V reflector lamp.

The table gives the luminous flux and efficacy of the lamp with four different beam angles. In each case

the light source is identical but it can be seen that the tighter the beam angle the lower the lamps efficacy becomes. It is difficult to design an efficient reflector producing a narrowly collimated beam. In order to make meaningful comparisons between different makes of reflector lamp it is necessary to know both the beam angle and the luminous intensity.

Example 4: Nichia LEDs

At the time of writing the Japanese manufacturer Nichia produces the best white-light LEDs available. **Table 4** gives data for some of these LEDs (each 5mm diameter LEDs operating at 20 mA with a forward voltage of about 4 V). Again the values of luminous intensity and yield are given.

The values of luminous intensity are very low compared to halogen lamps but they consume much less power also (20 mA × 4 V = 80 mW) so when we calculate the efficacy, these LEDs turn out to be comparable with halogen.

Example 5: Luxeon LEDs

Luxeon has recently introduced its range of LumiLEDs (**Figure 3**). These devices can handle 1 W of electrical power (330 mA at 3.4 V for a white LED). The values given in **Table 5** apply for the *lambertian* (or diffused) distribution pattern version of the LED.

The white light version has better efficacy than all of the Decostar halogen lamps and the coloured versions achieve excellent outputs. The *Royal Blue* version emits light with a wavelength of 450 nm and the eye is so insensitive to this colour that the luminous flux is given in milliwatts. This parameter gives some indication of the LED efficiency; 10% of the 1 W of electrical power is converted to visible light (**Figure 4**).

Example 6: 12-V LED Spotlight, 50 mm

The company Signal-Construct produce LED spotlights (available from Conrad Electronics) that can be driven directly from a standard 12 V transformer used for low voltage halogen lighting. Power consumption is 1.2 W. The data sheet indicates that these lamps have a beam

Table 5. Luminous flux for Luxeon LEDs.

Colour	Typical Luminous flux (lm)
WHITE	18
GREEN	25
CYAN	30
BLUE	5
ROYAL BLUE	100 mW
RED	44
AMBER	36

Table 6. Data for 12 V LED Spotlights.

Beam angle (degrees)	Luminous intensity (cd)	Luminous flux (lm, calculated)	Efficacy (lm/W, calculated)
50.0	30	17.7	14.7



Figure 3. 12 V LED Spot.

angle of 50° with a luminous intensity of 30 cd.

The efficacy of these lamps is comparable to standard LEDs (e.g., the 50° Nichia LEDs). Each spot contains 12 LEDs. Assuming a current of 20 mA per LED at 4 V this gives a total power consumed by the LEDs of 0.96 W. The power difference ($1.2 \text{ W} - 0.96 \text{ W} = 0.24 \text{ W}$) is most likely lost in the rectifiers and current control circuitry.

Are LEDs that cool?

One often reads that LEDs do not waste energy radiating heat and must therefore be far more efficient than, for example a halogen lamp. A close look at **Table 1** indicates that

the luminous efficacy of both LEDs and halogen lamps are really quite poor and only a small percentage of the input energy is converted into visible light. What happens to all that wasted energy? A conventional filament lamp consists of a hot wire filament enclosed in a glass envelope. Current through the filament causes it to glow white hot at around 1000°K so that a portion of the energy is radiated away as infrared (emission of IR radiation helps to keep the lamp relatively cool). Some of the heat is also conducted away (by convection) from the filament through the glass envelope and the body of the lamp.

With an LED it is not possible to make use of this 'radiant cooling', we

need to ensure that the semiconductor does not get much hotter than 120°C otherwise it will fail. At 120°C the radiant cooling effect is very small and there is very little infrared energy emitted. In high power LEDs it is therefore necessary to remove the wasted energy partly by IR radiation but mostly by convection using some form of heat sink with a large surface area to dissipate heat to the surrounding air. Using present day technology, if you were to build an LED with the equivalent light output of a 35 W halogen lamp one of your biggest headaches would be how to keep the device cool enough.

This is the reason why, for example, Luxeon LEDs are supplied in packages that allow attachment to a heat sink. When calculating the thermal properties of the heat sink it is usual to assume that all of the energy delivered to the LED will be converted to heat. The small amount of energy producing light can really be ignored. Electrically speaking (watts optically per watts electrically) even the most recently developed LEDs still have poor efficacy.

Luxeon LEDs

At the time of writing LEDs produced by Luxeon can handle the most power. Luxeon is a company formed as a Joint Venture between Agilent and Philips. These LumiLEDs (**Figure 5**) are currently available commercially and can handle 1 W. The white light LEDs have a forward conduction voltage of 3.4 V so this gives a current of around 300 mA. Like all LEDs the LumiLED has a sharp forward voltage conduction characteristic that means that it is not possible to drive them directly from a voltage source without some form of current limiting or constant current source.

The rear face of the LED has a flat metallic surface allowing attachment of a heat sink for cooling purposes. Continuous operation at 1 W is only possible if a small heat sink is fitted to dissipate the heat, without a heat sink the LED will become too hot and must be derated (run at a reduced forward current).

The projected lifetime for these devices is up to 100,000 hrs, this represents more than 10 years of continuous operation! The output luminous intensity will however decrease with time so that LED displays that you build now will get dimmer with time, after about 10,000 hrs we can expect to see a 20% reduction and after 40,000 hrs a further 20% reduction.

Comparing the life expectancy of an LED with a family car we could probably expect a vehicle to last for around 160,000 miles before it needs replacing, if we assume an average lifetime vehicular speed of 40 m.p.h. (admit-

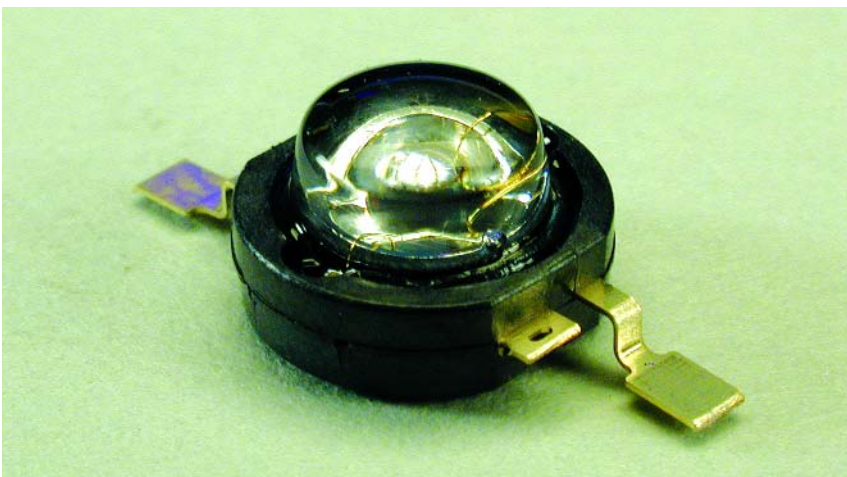

Figure 4. Luxeon LED.

tedly not very realistic for inner city dwellers in the U.K.) then with these figures the life expectancy of the car would be 4,000 hrs. Any LED fitted to the vehicle will easily outlive the car and will not need replacing, thus LEDs have advantages in applications where replacement would be difficult or expensive. There is a host of technical information available on the Internet showing applications along with electrical and thermal specifications including radiation patterns etc for the Luxeon LEDs. We have selected two circuits that might be useful to anyone wishing to experiment with these LEDs.

Luxeon LED driver using four NiMH cells

The simple circuit shown in Figure 6 is designed to drive a Luxeon 1 W LED from a 4 V to 6 V power source. The power can be provided ideally from four NiMH rechargeable cells. IC1 is a current source; it measures the LED current by sensing the voltage developed across the 0.2 Ω sense resistor R1 and resistor R2. The IC will adjust its output so that the voltage between the 'adj.' input and V- is 65 mV. The values shown in the circuit will give an LED current of approximately 250 mA. The reference voltage is proportional to the chip temperature referred to absolute zero and will only be 65 mV at room temperature (25 °C), as the chip temperature increases so will this reference voltage, leading to an increase in LED current. At 40 °C the LED current will be:

$$250 \text{ mA} \frac{273 + 40}{273 + 25} = 260 \text{ mA}$$

This should not be too much of a problem for most applications but it is important to ensure that IC1 is not fitted next to any component that will get warm e.g. T1 or the LED. One advantage of this circuit is the very low voltage drop across the sense resistor R1; this gives the circuit the characteristics of a low-drop current regulator. The input voltage should be kept below 6 V otherwise power dissipation in T1 will become excessive.

The 1 W LED is still quite expensive retailing at around seven pounds, for purposes of testing it is wise to use a 'dummy load' or in this case 'dummy LED' just to prevent damage to the LED during testing. Once the circuit has been checked the dummy LED can be removed and the LED fitted. Four 1N4007 diodes connected in series will simulate the loading provided by a single LED.

For testing connect the circuit to a variable power supply and increase the voltage gradually from zero. At about 3 V the circuit

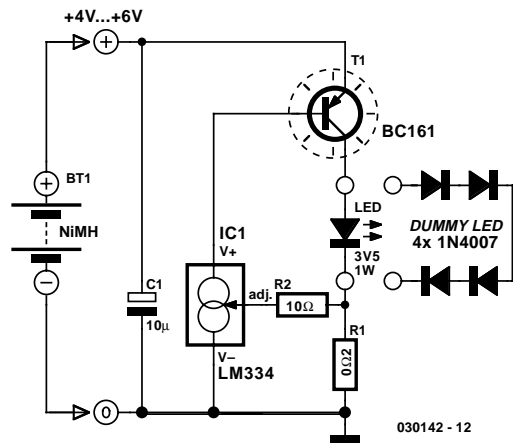

030142 - 12

Figure 5. 1 W LED with Linear regulator.

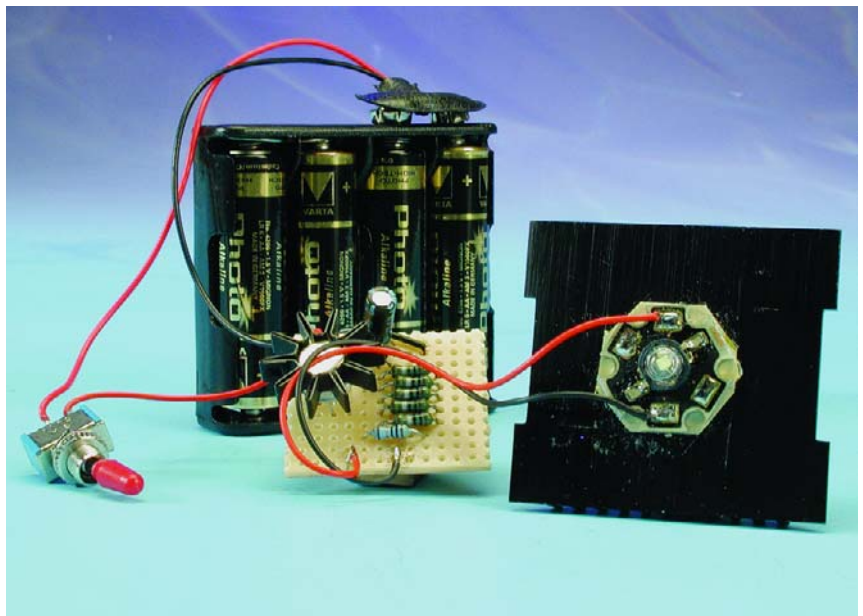
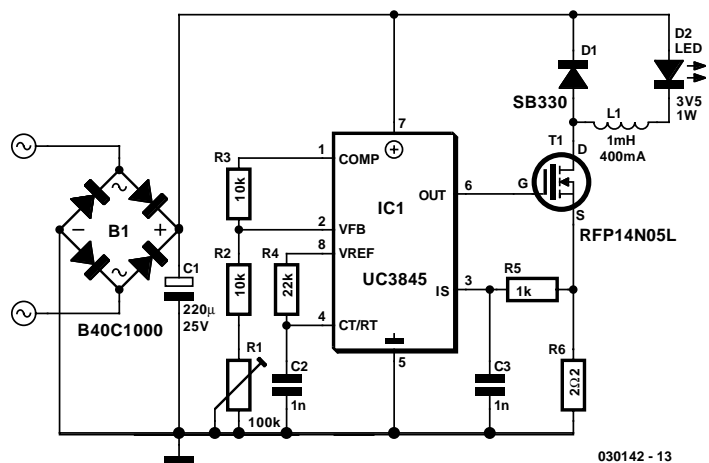

Figure 6. The low-drop current regulator built on prototyping board.



030142 - 13

Figure 7. A simple switched regulator with 70 % efficiency.

Web Addresses:

www.luxeon.com
www.nichia.com
www.int.conradcom.de
www.osram.de

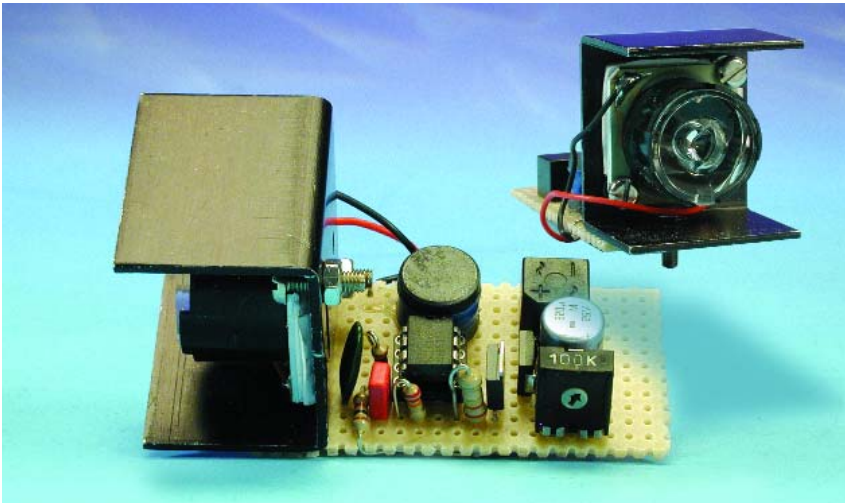

Figure 8. LED, heat sink and 12 V mains unit.

should be taking approximately 250 mA, increase the voltage to 6 V and check that the current does not increase. Once this test has been completed successfully disconnect the power and replace the dummy LED with the real LED. **Figure 7** shows the prototype circuit built on a small piece of PCB breadboard with a 1 W Luxeon Star LED.

LED operation from 12 V

The simplest technique of driving an LED from a 12 V power source is to use a linear regulator as shown above in **Figure 6**. This method is however not very efficient at 12 V because a lot of energy would be dissipated as heat in the regulator. A better alternative is to use a

switching regulator as shown in **Figure 8**. This circuit drives a 1 W LED and can be powered either from an ac or dc source (e.g., a 12 V transformer for domestic halogen lighting or a car battery). The efficiency is about 70%, which is not particularly good, but on a positive note the circuit does not need any special components.

The circuit uses a standard PWM (Pulse Width Modulated) IC type UC3845 in 'current' mode. The RC network R4/C2 controls the switching frequency while the value of R2/P1 defines the output current. A relatively large inductor (L1) is used to ensure that the current ripple is kept low. Current through the LED is not regulated directly but instead the regulator controls peak current through the inductor. This technique

avoids the need for a current sense in the LED path.

For circuit testing purposes the dummy LED can be used again as before. Once the input voltage exceeds 10 V the circuit will start to oscillate and P1 can be adjusted to give 250 mA through the LED. With a 12 V dc power source the circuit consumes about 120 mA. The LED current should not change when the input voltage is varied (at least not appreciably). When the tests are complete the dummy load can be replaced by a 1 W LED and the circuit can be powered directly from a 12 V halogen lighting transformer, this should give a suitably high-tech ambiance to your domestic lighting set-up!

The Luxeon STAR/O LED can also be used in this circuit. This device has integrated optics and must be fitted to a heat sink if it is to be used for continuous operation. The LED can be mounted to the heat sink using a flexible, (electrically) insulated gasket.

Back to the future

Future advances in LED technology will undoubtedly lead to a more widespread use of semiconductor light sources, there are already devices with operating currents of 700 mA and increasingly we see LEDs replacing filament lamps in applications such as traffic lights, production car tail-light clusters and backlighting LCD monitors.

(030142-1)

Acoustic Noise Control Device

A. Pozhitkov

Please note: Readers' Circuits have not been tested or post-engineered by the Elektor Electronics design laboratory.

The circuit described here is used to control the acoustic noise levels produced in a room or office. The main idea behind installing the device is that it employs asks human speech to request the people making noise to be quiet. The circuit is quite complex because the device reacts not only to a certain instantaneous noise level but on its duration as well. For example, the device will ignore coughing and sneezing noises. However, if someone sneezes too often and too loud the device will react with an appropriate warning message.

How it works

The circuit diagram of the device is given in **Figure 1**. It can be divided onto four parts.

The first part is a run of the mill microphone amplifier assembled around an LF352 opamp. The second part is the 'logic' of the unit — it is found around a 4027 J-K flip-flop. The third section is the speech recording and playback section based on the IC ISD1400. The last part is an AF power amplifier enabling the device to address the culprits, using a convincing volume for the warning message.

The first and fourth parts are not too complex. The only things that are worth mentioning are that P1 is the sensitivity control and P2 is the volume control. Preset P1 regulates the negative feedback on the micro-

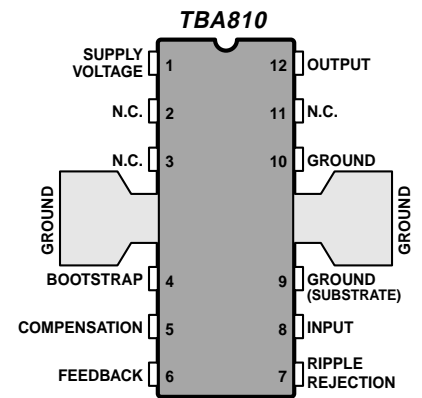
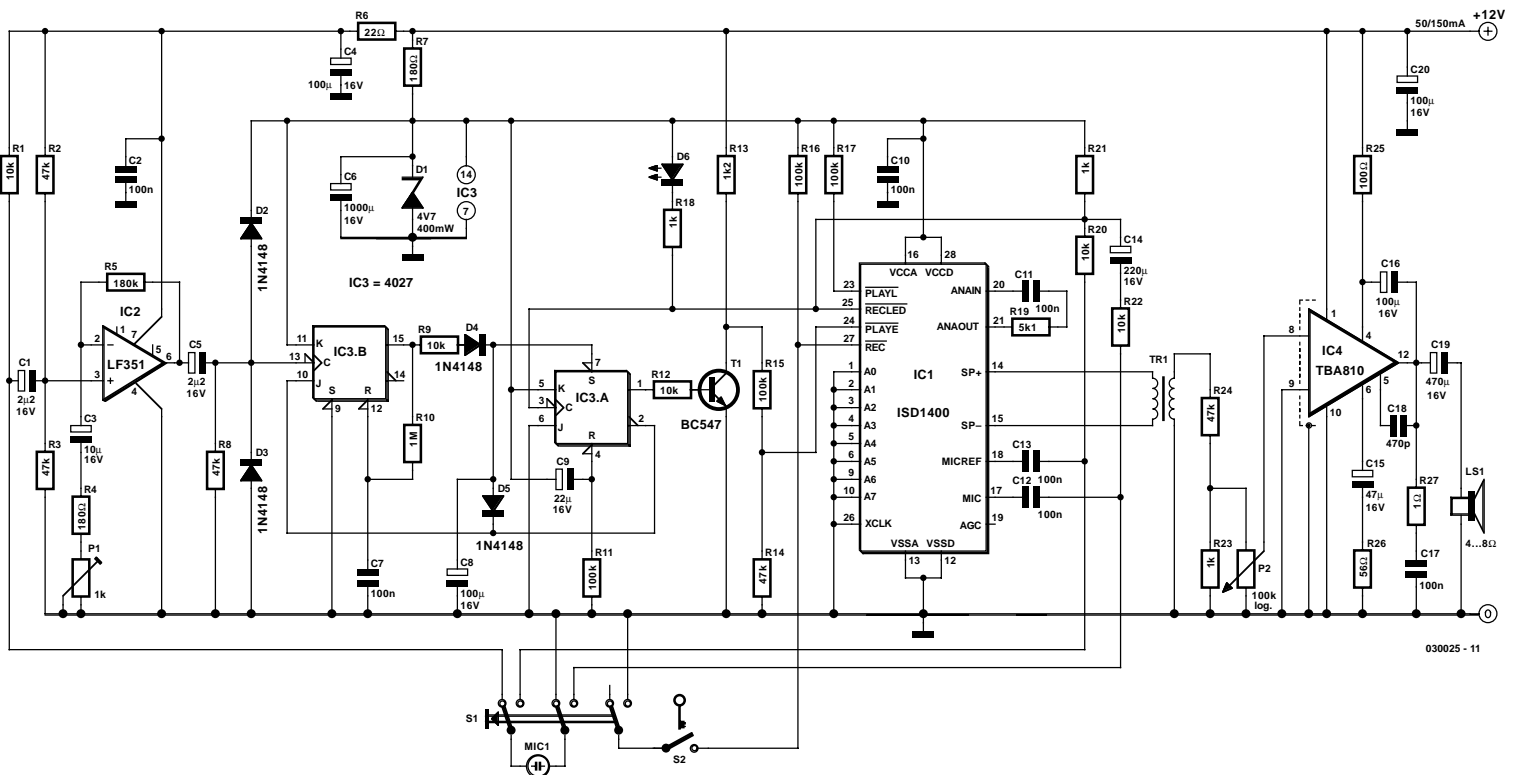

Figure 1. Circuit diagram of the Acoustic Noise Control Device.



phone amplifier and P2 determines the signal level fed to the AF power amplifier input.

The logic used in the circuit is more interesting. After switching on, J-K flip-flop IC3A has its non-inverting output Q at Low. Thus, the J and K inputs of the other flip-flop, IC3B, are held High. The amplified signal from the microphone amplifier, if it has enough level (take into account the sensitivity control), causes IC3B to be clocked. The flip-flop is wired such that it resets itself in a short time (around 0.1 s, determined by R10-C7).

In this way, the microphone signal of any form is 'digitised' into pulses with a duration of 100 ms. At the same time these pulses charge C8 by way of R9. The value of C8 (100 μ F) determines the tolerance of the device to sneezing, coughing and so on. When the voltage on C8 is sufficiently high, IC3A toggles, its Q output flipping High and the inverting output, Low. Consequently, C8 is

discharged and a Low level is established on the J input of IC3B. This level prevents J-K flip-flop IC3B from producing further pulses regardless of what's going on at its clock input. At the same time T1 starts to conduct, enabling the ISD1400 chip to play back a pre-recorded message. During the playback period the device does not 'hear' itself because IC3B is blocked. When the message is over, the ISD1400 briefly pulls its RECLEd output Low, thus resetting the logic part of the circuit to its initial state.

The voice recording/ playback machine

The ISD1400 Chipcorder® is configured according to its standard application circuit gleaned from the product brief posted by Information Storage Devices at www.winbond-usa.com/products/isd_products/chipcorder/productbriefs/1400_product_brief.pdf

Applying a Low level to its REC input activates recording — playback is triggered by a falling pulse edge at the PLAYE input. During recording the RECLEd output goes Low, causing LED1 to come on. At the end of the playback period, RECLEd goes Low briefly, which is an indication of the end of the message.

The rest of the circuit is quite simple. Changeover switch S1 enables to use the same electret microphone to be used for recording and monitoring. S2 is a key driven switch preventing the device from recording messages from non-authorized persons (like all too funny students).

The circuit draws about 50 or 150 mA in the standby and activate state respectively. The high value is obviously dependent on the playback volume set on P2.

All components including the 1:1 (600 Ω :600 Ω) audio transformer were purchased from Conrad Electronics either separately or as parts of kits. Conrad Electronics' English-language (international) website is at www.int.conradcom.de.

(030025-1)

DTMF Remote Telephone Switch

Design by U. Reiser

In spite of alternatives based around the Internet, SMS and e-mail, the good old DTMF remote switch still has its place, and, thanks to the use of a modern microcontroller, is simple and economical.



Today a telephone connection is available anywhere and at any time, with forms of communication other than speech having been available for some time. Alongside SMS and WAP there is the simpler established technology, known as 'Dual Tone Multi Frequency', or DTMF for short, which we use here in order to control a circuit. Telephone

service providers have used this dialling system in the analogue telephone network to replace pulse dialling, which dates from days of mechanical uniselectors. Once a telephone connection is in place, a transmitted tone can be used in order to trigger a desired action. This

technique, well known from its use in remotely accessing answering machines or conversing with service providers, here allows us to use the keypad to control three circuits once a call has been set up.

Circuit Operation

The remote control switch is connected in parallel with the telephone apparatus: this does not restrict the use of the telephone in any way. After a selectable number of rings the circuit lifts the receiver and sends an acknowledgement tone to signal to the caller that a four-digit code number is to be entered. Ten seconds are allowed for the entry of each digit, and each digit is acknowledged by a tone. If the time limit is exceeded, an error sound is produced and the receiver replaced on-hook.

Once all four digits are received they are compared with stored code numbers. If the digits are not in agreement with any of the stored numbers, the error sound is again produced and the call is terminated. The circuit is then immediately ready for a new call.

Each of the three switching outputs is assigned two sequences of digits, one to switch the output stage on and the other to switch it off. If the same four-digit number is received a second time, the circuit

does not change state. The states of the outputs are stored in EEPROM in the PIC and so are preserved in the case of a power failure. Programming the six sequences of digits and the selection of the number of rings is done using the telephone, which should be connected to the programming socket for this purpose. These digit sequences are also permanently stored in EEPROM in the PIC.

The full circuit of the remote telephone switch is shown in **Figure 1**. The PIC16F84 microcontroller (IC3) examines incoming signals on port B and controls the outputs over port A. Connection to the telephone network is via RJ45 connector K2. Socket K3 is connected in parallel with socket K2 and allows a telephone to be connected at the same time as the circuit. Since in practice the pinout of the connectors is rather less standardised than it is in theory, we have used jumpers here. A voltage-dependent resistor (varistor) is connected across these two sockets, which provides protection against voltages in excess of 130 V.

The DTMF signal to be processed (an AC signal with a DC offset) is brought in to the circuit via D1 to D4.

Because of this diode bridge, the polarity of the signal is no longer relevant. The ring signal is an AC voltage, which passes through capacitor C1 to bridge rectifier D5 to D8. Since this voltage can be as high as 60 V, an optocoupler (IC1) is used before the input to the PIC. Capacitor C1 ensures that only the ring signal, and not the DC offset, reaches the optocoupler.

IC2 is a DTMF decoder type MT8870. It is connected to the telephone line via C3 and R10 and presents a hexadecimal value corresponding to the two tones at its outputs Q1 to Q4. These outputs are latched and so are only valid when the control output STD is high. Inputs RB6 and RB7 are used as two auxiliary inputs to control the PIC. Pushbutton switch S1 puts the PIC into programming mode, allowing the possible entries shown in **Table 1**. Jumper JP1 selects between a permanently enabled output or an output switched on for just five seconds. This function allows the operation of door openers with a single call, for example. Type CNY17 optocouplers are used at the switching outputs, which

provide an isolated connection to the outside world on connectors K5 to K7. The optocouplers can switch voltages of up to 35 V at currents of up to 10 mA. They also prevent an earth potential from a controlled device from coming into contact with the remote control switch. Since this earth potential is also on the telephone line, this can lead to interference on the telephone connection if isolation is not used. Signal output to the telephone line is via two transistors. T3 produces a line current of approximately 20 mA, which corresponds to lifting the receiver. When T1 is driven by the PIC, it is switched on and off at a frequency of 325 Hz and adds an extra alternating current of 2 mA. This causes the caller to hear a tone. T2 fulfils the same function, creating a tone on the telephone connected to K1.

Two supply voltages are required for the remote telephone switch circuit. A DC or AC 12 V mains adaptor is connected to bridge rectifier B1 via K4. IC2 and IC3 are supplied with a regulated 5 V from a 7805 fixed voltage regulator. The unregulated voltage of approximately 12 V is required only for the telephone used in programming mode. The voltage appears across the contacts of K1 and a current flows through the telephone apparatus and R1 to ground. A DTMF signal also appears across R1, which is taken to the input of the MT8870 via C4 and R11.

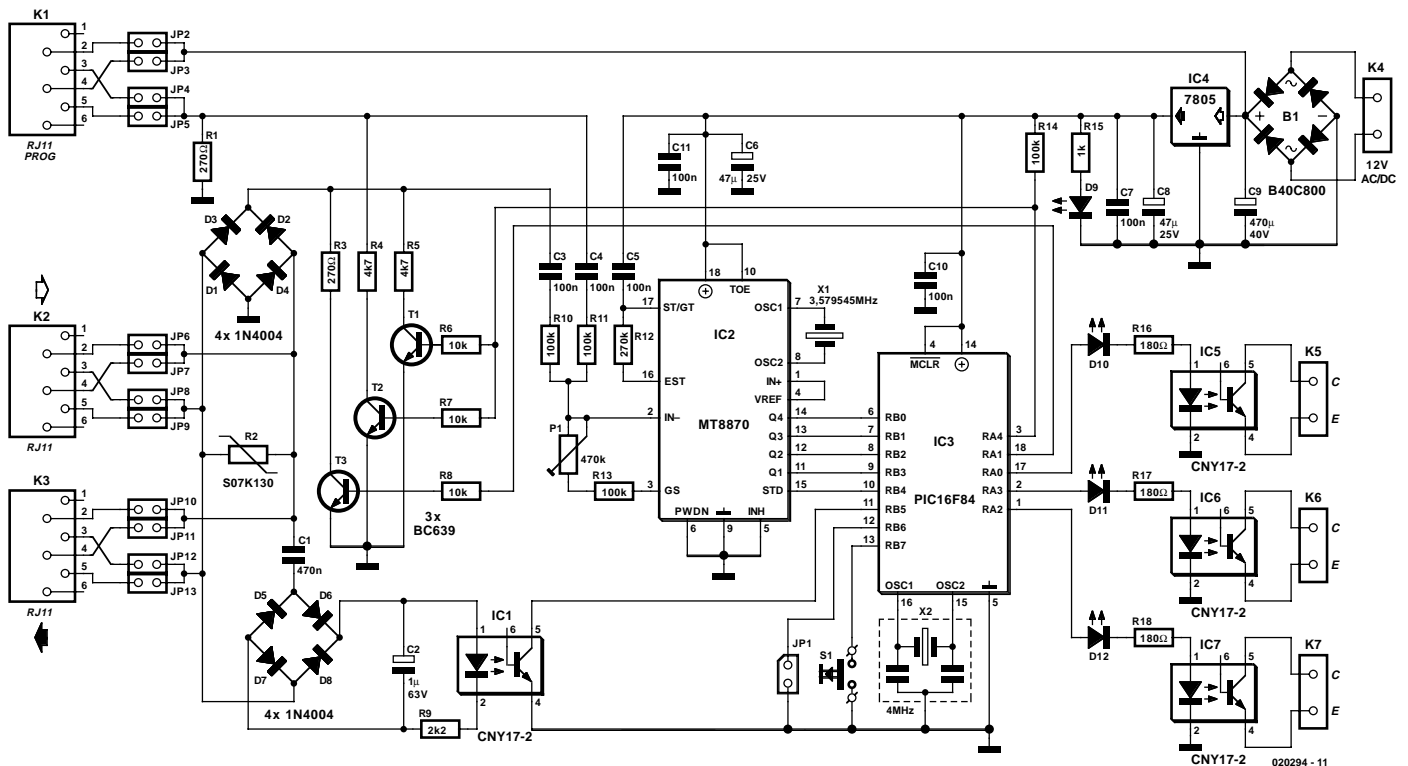

Figure 1. Circuit diagram of the telephone remote control.

The Software

The PIC is the central control component and monitors the state of the telephone line, reads hexadecimal values corresponding to DTMF tones, lifts the telephone receiver, transmits acknowledgement signals and switches the output stages. All these functions are implemented in the PIC assembler program **020294.ASM**. A simple illustration of the operation of this program is shown in the flowchart of **Figure 2**. First of all the inputs and outputs are initialised. All the port A connections are configured as outputs and all the port B connections as inputs. The internal pull-up resistors on port B are enabled. Next, the values stored in EEPROM corresponding to the six digit sequences and ring count are copied into RAM.

The main program now starts by reading the state of the programming button (S1) and the ring detector (IC1). If neither of the signals is active, they continue to be monitored in an infinite loop.

If the programming button is detected as being pressed the programming subroutine is entered. Here five digits are read in sequence, corresponding to the control of an output stage. The first digit specifies the function of the digit sequence, as well as its storage location in EEPROM. If a ring signal is detected the ring counter is decremented: when it reaches zero, the receiver is lifted (via RA1).

To confirm that a call has been picked up, two 400 ms signal tones at 325 Hz are emitted. In subroutine **READDTMF** the value corresponding to a DTMF signal is read when input RB4 goes high. This reading process is repeated four times and the digit sequence received is stored in registers **NUMBERHI** and **NUMBERLO**. Then the digit sequence that has just been read is compared with the stored values in six identical program segments (**COM1ST**, etc.). If no number matches, control passes to program segment **WRONG**, where six 325 Hz signal tones of 200 ms duration spaced at 100 ms intervals are emitted, and the receiver replaced on-hook.

If a match occurs with one of the six stored digit sequences the appropriate control action is carried out: the corresponding output stage (IC5 to IC7) is turned on or off. The first output is a special case. When it is turned on, the level at RB6 (i.e., jumper JP1) is checked. If it is low, IC5 is automatically turned off again after a five second delay. If, on the other hand, JP1 is open, the output turns on permanently. After each control action an 800 ms confirmation tone is emitted.

In the following program segment the

state of the three output stages is stored in EEPROM at address 0Eh. Then the main program is begun again with a **GOTO START**. All tests, such as ring recognition, ring pause, DTMF recognition and DTMF pause time out after ten seconds if the corresponding event does not occur. After an error tone is emitted and

the receiver is replaced on-hook (**GOTO WRONG**), and control returns to the start of the program.

Construction

Construction of the telephone remote control is easier than might appear from a first look at the layout

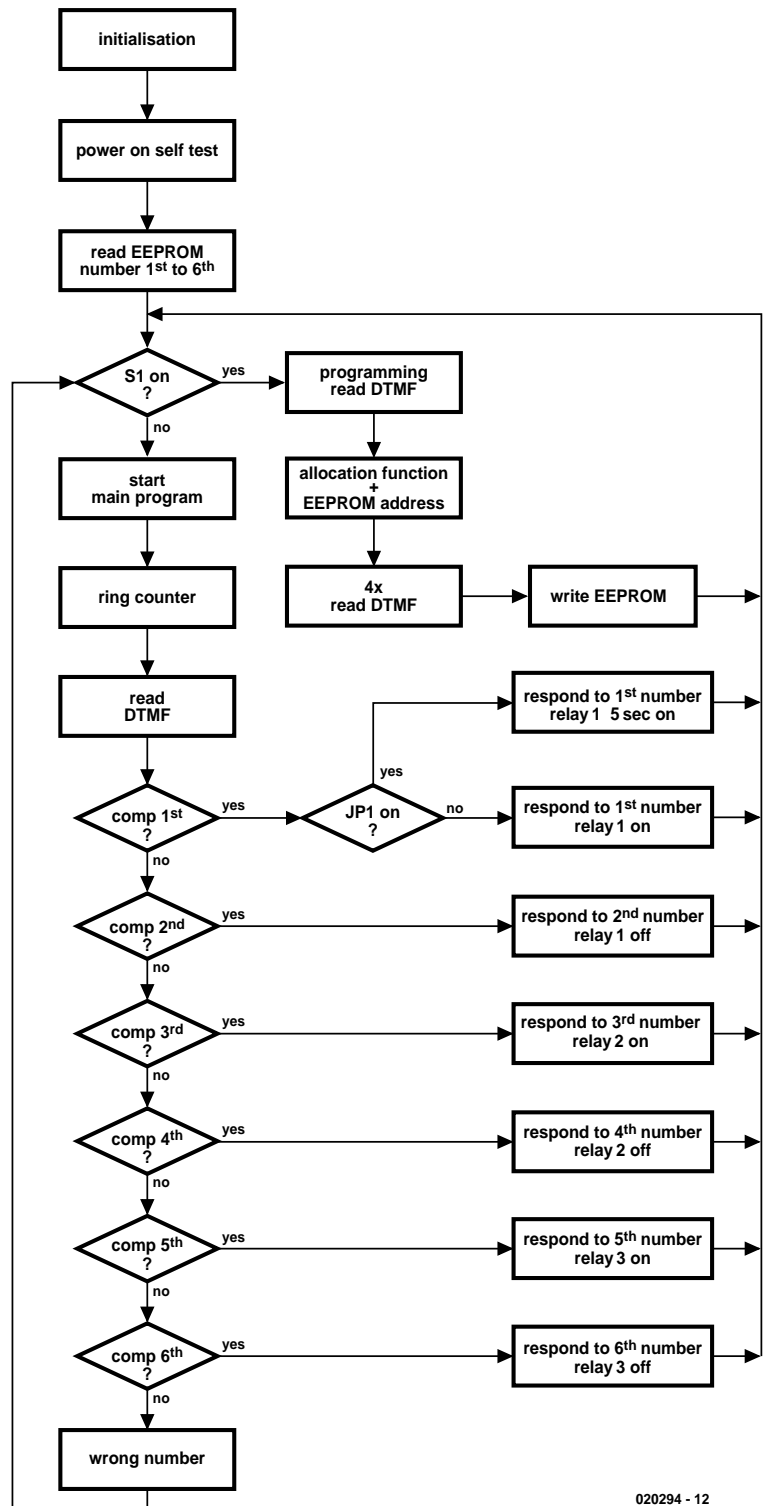

020294 - 12

Figure 2. Software flowchart.

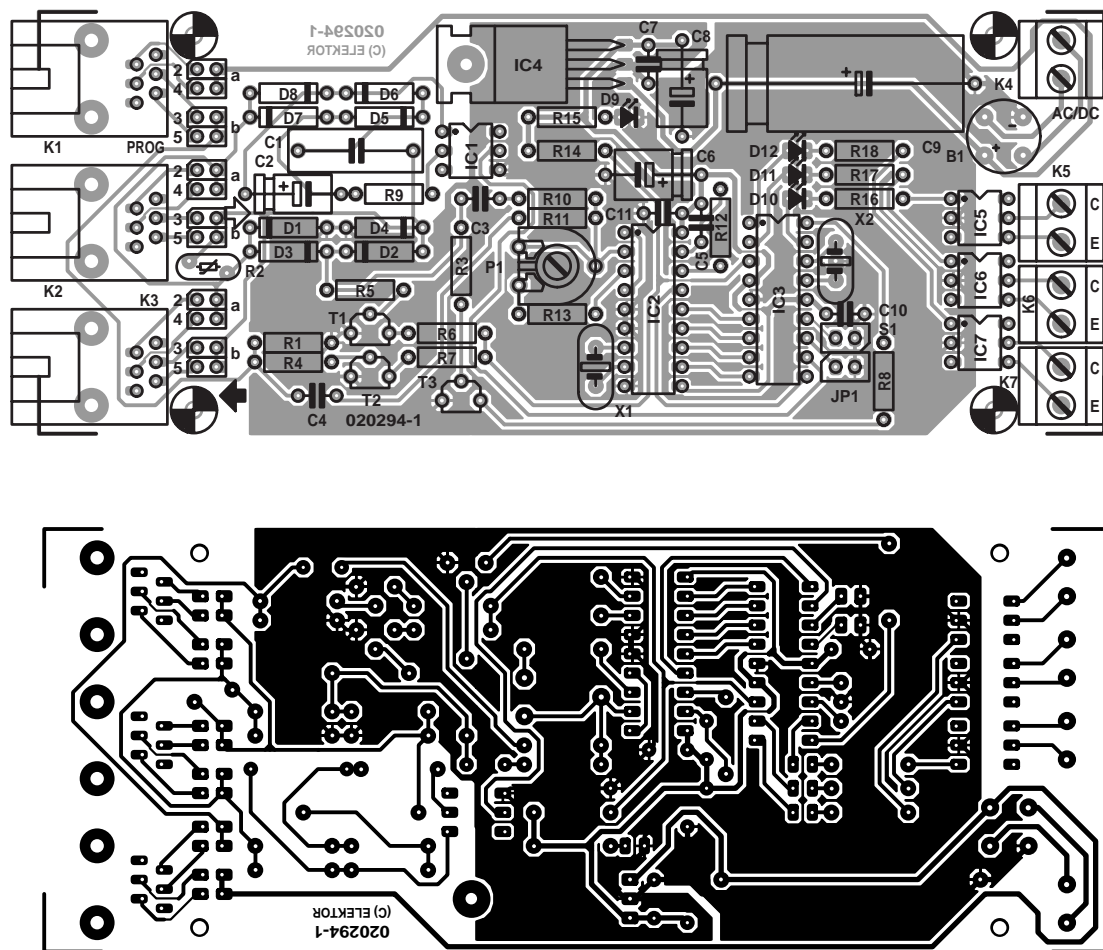

Figure 3. Layout and component mounting plan for the telephone remote control.

COMPONENTS LIST

Resistors:

- R1,R3 = 270Ω
- R2 = S07K130 (130V varistor)
- R4,R5 = 4kΩ
- R6,R7,R8 = 10kΩ
- R9 = 2kΩ
- R10,R11,R13,R14 = 100kΩ
- R12 = 270kΩ
- R15 = 1kΩ
- R16,R17,R18 = 180Ω
- P1 = 470kΩ (500kΩ) preset

Capacitors:

- C1 = 470nF 100V MKT, lead pitch 5mm
- C2 = 1μF 63V axial
- C3,C4,C5,C7,C10,C11 = 100nF, lead pitch 5mm
- C6,C8 = 47μF 25V axial
- C9 = 470μF 40V axial

Semiconductors:

- B1 = B40C800, round case (80V piv, 0.8A)
- D1-D8 = 1N4004

- D9 = LED, low current, red, 3mm
- D10,D11,D12 = LED, green, 3mm
- IC1,IC5,IC6,IC7 = CNY17-3
- IC2 = MT8870DE
- IC3 = PIC16F84A-20/P, programmed, order code **020294-41**
- IC4 = 7805
- T1,T2,T3 = BC639

Miscellaneous:

- JP1 = 2-way pinheader with jumper
- K1,K2,K3 = RJ11, PCB mount
- K4,K5,K6,K7 = 2-way PCB terminal block, lead pitch 5mm
- S1 = pushbutton, 1 make contact, chassis mount
- X1 = 3.579545MHz quartz crystal
- X2 = 4MHz 3-pin ceramic resonator
- Optional: 24-way SIL pinheader with 6 jumpers
- PCB, order code **020294-1**
- Disk, project software, order code **020294-11** or Free Download

and component mounting plan in **Figure 3**. All the components are 'normal' leaded ones (no SMDs), the printed circuit board is single-sided but nevertheless is free of wire links. Sockets are recommended for the ICs. Be careful to observe correct polarity for the many diodes and electrolytic capacitors (and of course for the ICs).

The jumpers next to the telephone sockets may be inelegant, but are necessary. Unfortunately, with the RJ11 analogue telephone connector, there appears to be no effective international agreement on the pinout. In a few countries, telephones are connected across pins 2 and 5, in most, however, across pins 3 and 4. For this reason we have included the facility on the printed circuit board to accommodate either possibility: the correct connections can be selected using jumpers JP2 to JP13, or using wire links. No damage can be done in this way: either the circuit will work or it will not.

For a first test of the telephone remote control IC2 and IC3 should not be fitted in their sockets. Once the two supply voltages have been verified, the operation of the optocou-

Table 1 Programming mode					
Entry					Function
1	2	3	4	5	
0	X	0-10	X	X*	Ring count
1	X	X	X	X	K5 on
2	X	X	X	X	K5 off
3	X	X	X	X	K6 on
4	X	X	X	X	K6 off
5	X	X	X	X	K7 on
6	X	X	X	X	K7 off

X = any DTMF key
* = 0, * and # = 10

plers can be checked. To do this, apply a high level to pins 1, 2 and 17 of the (empty) IC3 socket. The corresponding LED should light and the output transistor of the optocoupler should turn on. The output transistor of IC1 should also conduct when a ringing voltage is present on socket K2. Since K2 and K3 are wired in parallel, it is unimportant which is used as an input and which as an output.

The tone signal output can be tested by applying a high level to RA1 and RA4: the result should be a crackling sound in the telephone earpiece. When testing T1 and T3 in this way, the circuit must be connected to the telephone network, since this function depends on the voltage it provides.

Once all tests are successfully completed (and all power sources are disconnected from the circuit) IC2 and IC3 can be fitted.

Now, when power is applied, the 'line sound' (325 Hz), along with the programming tone (2 kHz and 2.5 kHz) should be audible at

K1 and K2. The next step is to set the gain of the MT8870. This is done by first lifting the receiver and pressing any number key. A high level at STD on IC2 (pin 15) indicates correct recognition of the DTMF signal. The adjustment is carried out using potentiometer P1. Either K1 or K2 may equally well be used.

Number entry

Now the six sequences of digits can be entered, along with the ring count. First S1 must be pressed: this is acknowledged by a tone in the earpiece of the telephone connected to K1. If the program has recently detected activity on the telephone line (a ring signal or a DTMF tone), the timeout period must be allowed to expire before programming mode can be entered.

Now the first digit can be entered (indicating the function according to **Table 1**), followed by a four-digit sequence. All entries are acknowledged by a signal tone (see **Table 2**). Four digits must be entered even when the ring count is being set, although only the second digit is significant, indicating, from 1 to 9, the number of rings. If a different key is pressed (0, * or #), the ring counter will be preloaded with 10. It is not possible to read the stored values out of the memory. If they are forgotten, the only solution is to reprogram them afresh.

When the PIC is first used after its program code has been loaded

into it, all the output stages are turned on, the ring counter is set at 10 and all digit sequences are set to 'CCCC' (in DTMF code). These values are changed when the unit is first configured using DTMF tones.

The circuit can be tested by simply calling oneself and watching the effect of the call and the received signals on the receiving telephone and on the remote control. There is also the possibility of carrying out this test without incurring the cost of a telephone call. Remove optocoupler IC1, connect socket K2 to the telephone network and lift the receiver on the telephone connected to K3. The collector and emitter connections of IC1 should be bridged for about one second to simulate a ring: this should be done a suitable number of times, according to the ring count setting.

The call acknowledgement tone should be heard in the earpiece, and a four-digit sequence should be entered. The signal tones shown in the table should be heard, overlaid by the tones from the connected telephone. During this process the tones entered can cause an outgoing call to be set up, and so use of the other connector is recommended for programming. If the circuit is not to be used for some time, the power supply should be disconnected, but the telephone connection need not be unplugged. Note that this means that if there is a power cut, the telephone connection will not be blocked.

(020294-1)

Table 2 Tones produced when receiving digit sequences and during programming	
Action	Tone sequence
Incoming call received	C, C, W, W, C, C
Entry acknowledgement	Digits 1 to 3: C; digit 4: confirmation or error signal
Output on/off confirmation	C, C, C, C
Error: operation aborted	C, W, C, W, C, W, C, W, C, W, C
Programming mode entry	B, B, A, A, B, B, A, A, B, B
Programming mode entry acknowledgement	Digit 1: B or error signal; digits 2 to 4: A; digit 5: confirmation
Programming confirmation	A, B, A, B, A, B, A
Error: programming mode aborted	B, W, B, W, B, W, B, W, B, W, B

Key: A = 2500 Hz / 100 ms; B = 2000 Hz / 100 ms; C = 325 Hz / 200 ms; W = 100 ms pause

Note:

the circuit described in this article is not BAPT approved for connection to the public switched telephone network. Approval has not been applied for.

Free Downloads

Microcontroller software (hex and source code).
File number: **020294-1 I .zip**
PCB layout in PDF format.
File number: **020294-1 .zip**
www.elektor-electronics.co.uk/dl/dl.htm, select month of publication.

Precision Measurement Central (2)

Part 2: printed circuit board and software suite

Design by J. Wickenhäuser

www.wickenhaeuser.com

The solid base of the Precision Measurement Central (or 'Elektor Meter') is the powerful MSC1210 development system and an I²C LC display unit described elsewhere in this issue. This base and the software suite described this month will be used in a number of future projects employing the highly interesting MSC1210 microcontroller.

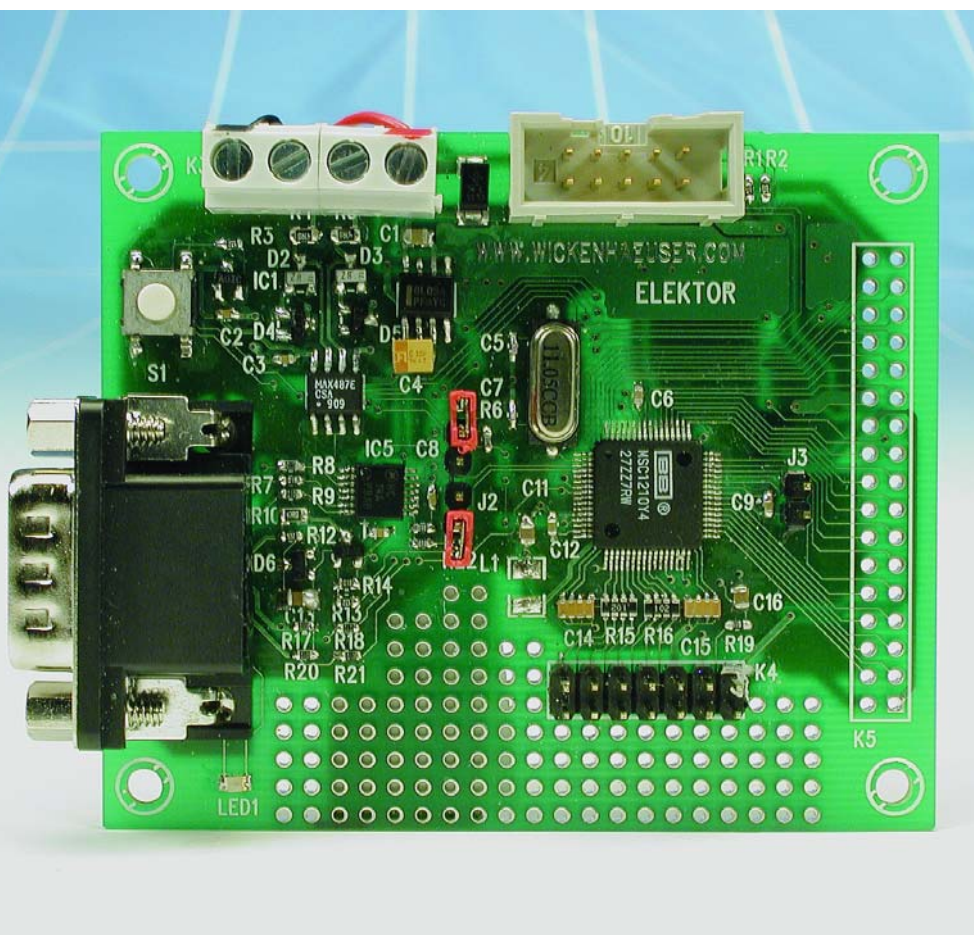

First, however, we need to 'wrap up' the hardware side of things. In the previous issue (July/August 2003) we discussed the operation of the MSC1210 controller board along the lines of its circuit diagram. For lack of space in the first instalment we could not include the layout of the double-sided printed circuit board and the associated component lists. With a 'thank you for your patience' to many dedicated readers we can now print these two items, see **Figure 1**.

As already announced in the July/August 2003 issue, the board we're talking about is not available unstuffed from the Publishers. The good news is that the MSC1210 controller board (as shown on the photograph) comes **ready-populated and tested**. The photo tells you why: the risk of construction errors using tiny parts, an extremely condensed board layout and kitchen table methods to populate the board is immense!

Industrially manufactured MSC1210 controller boards are available through Elektor's Readers Services under number **030060-91** (see

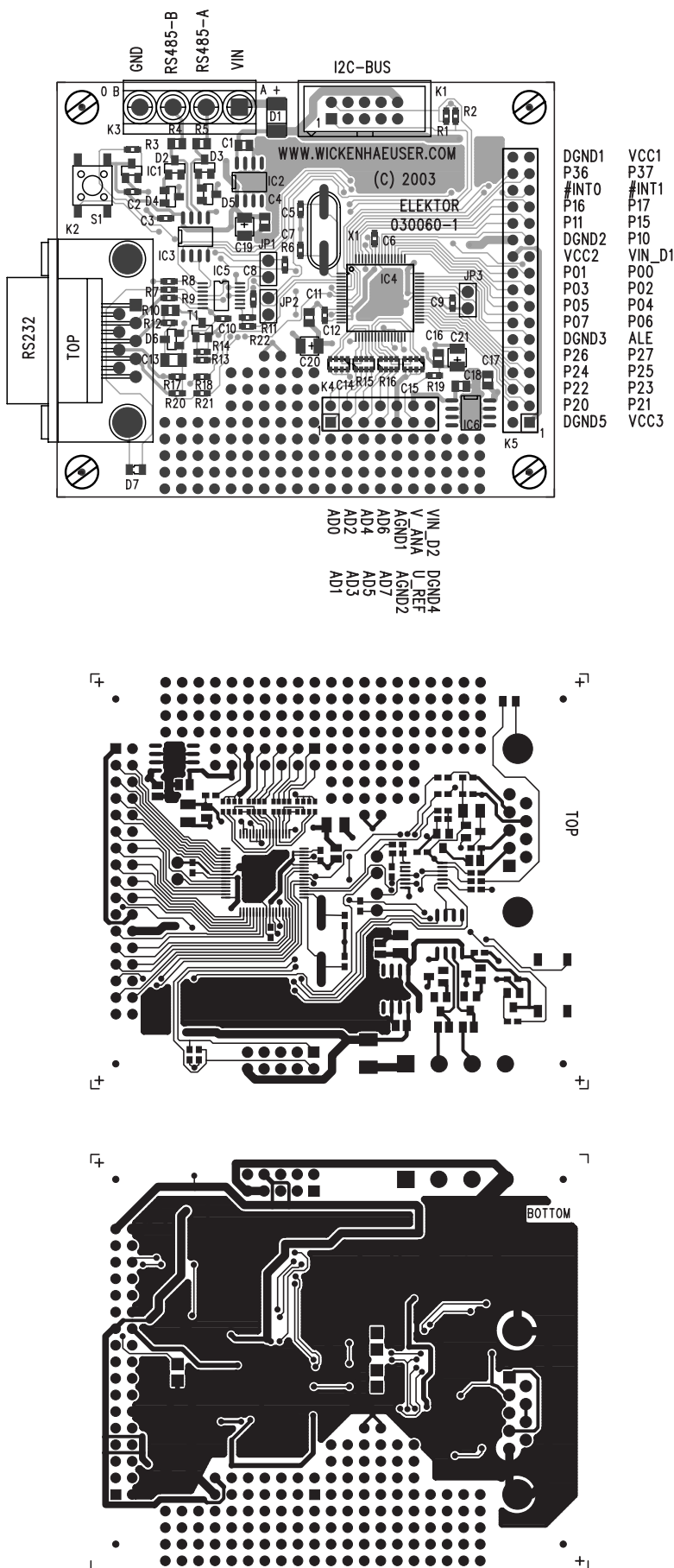

also our website www.elektor-electronics.co.uk). However, in good Elektor tradition, the PCB layouts are available as a Free Download for those of you having the SMD components, equipment and where-withal to attempt home construction.

Besides the MSC1210 board, the system hardware only comprises a zero-modem

COMPONENTS LIST

All parts: SMD [shape code]

Resistors:

R1,R2,R3,R12,R13 = 4k Ω 7 [0603]
 R4,R5,R10 = 47 Ω [0805]
 R6,R7,R11,R14 = 1k Ω [0603]
 R8,R9,R17,R18,R20,R21 = 100k Ω [0603]
 R15,R16 = 4 x 1k Ω [1206], resistor array
 R19 = 10 Ω [0603]

Capacitors:

C1,C4,C11,C16,C17,C18 = 470nF [0805],
 $V \geq 16V$
 C2,C3,C6,C9,C10,C12 = 100nF [0603]
 C5,C7 = 10pF [0603]
 C8 = 1nF [0603]
 C13 = 2 μ F2 [1206], $V \geq 16V$
 C14,C15 = 4 x 100nF (or 47nF) [1206],
 capacitor array
 C19,C20,C21 = 10 μ F 6V3

Inductor:

L1 = 100 μ H [1206] $R_d < 10\Omega$

Semiconductors:

D1 = GF1M [DO214]
 D2,D3 = BZX84 [SOT23], 9V1
 D4,D5 = BZX84 [SOT23], 4V7
 D6 = BAW56 [SOT23]
 D7 = LED, red, [0805]
 T1 = BC857B
 IC1 = MAX810 or similar
 IC2,IC61 = 78L05 [SO8]
 IC3 = MAX 487ECSA, 485, SN75176 or
 equivalent RS485 converter
 IC4 = MSC1210 Y4 (Texas Instruments)
 IC5 = 74HC14ADT [TSSOP14]

Miscellaneous:

K1 = 10-way boxheader
 K2 = 9-way sub-D plug (male), angled, PCB
 mount
 K3 = 4-way PCB terminal block, lead pitch
 5mm
 K4 = 14-way pinheader (2 rows)
 K5 = 34-way pinheader (2 rows)
 J1,J2,J3 = jumper, 2-way, lead pitch 5mm
 X1 = 11.0592MHz quartz crystal, miniature
 S1 = SMD pushbutton
 Order code for ready-stuffed and tested
 board: 030060-91.

Figure 1. Artwork for the double-sided, SMD populated board.

RS232 cable, a mains adapter (o/p 7.5-15 V direct voltage) and, of course, a PC. The LC display described elsewhere in this issue is not strictly necessary, although it is used by a number of C demo programs. In all cases, text can be sent via the RS232 path to a terminal (emulation) program running on the PC.

Software

Specially for constructors of the MSC1210 Precision Measurement Central, the author has bundled a number of software utilities into an

MSC1210 'suite', containing all available documentation, compilers, downloaders, programs and source code files. To be able to use these 'tidbits' on your PC you'll need to have WinZip (to extract the files from a large archive) and a PDF viewer like Acrobat Reader. Both are commonplace programs these days and should be available on most PCs. If not, they are available free of charge on the web. The same goes for the archive file **030060-11** which may be found in this month's Free Downloads section of the *Elektor Electronics* website. The directory structure is illustrated in **Figure 2**, while the function of the folders and files is explained in **Table 1**.

Installation

Having read the ReadMe file you are ready to install the software required for a Windows PC. It is best to begin with the file

uC51_Inst.EXE which not only contains the C compiler proper, but also the compiler reference manual, source codes and datasheets for the controller board, the Precision Measurement Central ('Elektor Meter') and the LC display.

A Downloader utility is required any time you want to blow a project into the MSC1210 micro. For your first attempts, we recommend the original Texas Instruments downloader contained in the file **DownloaderVxxx.zip**. Advanced users may prefer Robin Kucera's **MSC-Loader.exe**.

The 'ADC Demo' from TI discussed in part 1 of this article makes an excellent introduction into MSC1210 architecture, programming and downloading. The program may be extracted from the archive file **ADC Demoxxx.zip**, which, in turn, is contained in the larger archive.

(030060-1A)

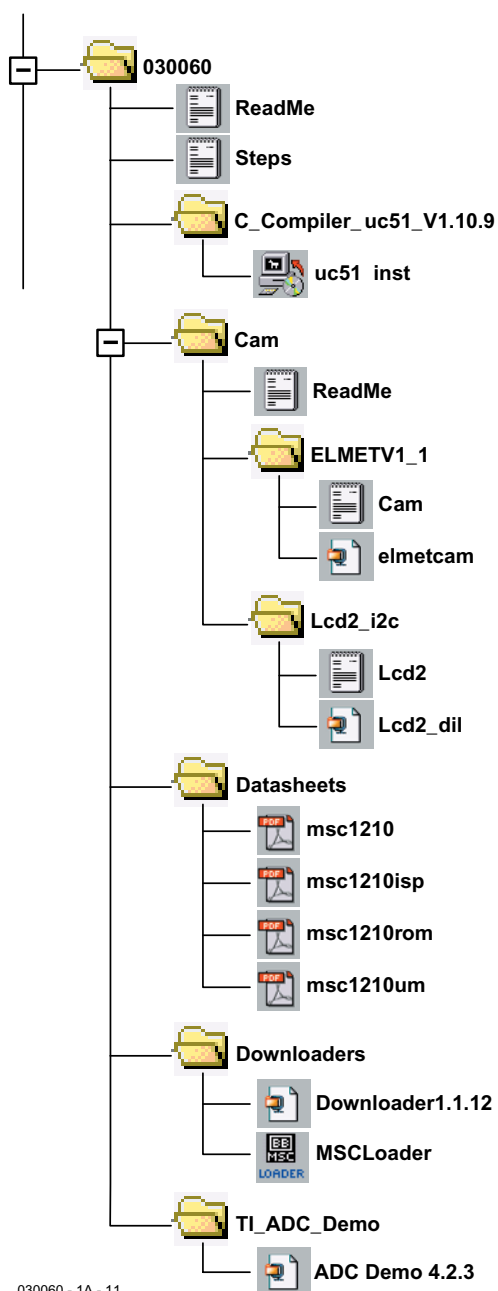

030060 - 1A - 11

Figure 2. Directory structure of the software suite developed for the MSC1210 system.

Table 1

Directory structure (ref. Figure 2).

1	ReadMe.TXT	MUST be loaded first
2	Steps.TXT	This text (English)
3	C Compiler uC/51_Vxxx\	C Compiler directory
4	uC51_Inst.EXE	Code optimizing ANSI C Compiler uC/5 (8-kB demo version)
5		All source code files and additional documents
6	CAM\	CAM data directory (create when erased)
7	ElmetV1_1\	Elektor Meter subdirectory
8	CAM.TXT	Information on producing PCBs
9	ELMETCAM.ZIP	All PCB data for the Elektor Meter
10	LCD_I2C\	I2C LC Display subdirectory (author's SMD version)
11	CAM.TXT	Information on producing PCBs
12	LCD2_DIL.ZIP	All PCB data for the I2C LC Display (author's DIL version, not published in Elektor)
13	DATASHEETS\	Quick reference material on MSC1210
14	MSC1210.PDF	MSC1210 datasheet
15	MSC1210ISPPDF	ISP manual (not applicable when using a Downloader)
16	MSC1210ROM.PDF	MSC1210-API (TI's built-in functions)
17	MSC1210UM.PDF	Craig Steiner MSC121x-Family User Manual
18	DOWNLOADERS	Downloader directory
19	DownloaderVxxx.ZIP	Original TI Downloader
20	MSCLoader.EXE	Robin Kucera's Downloader
21	TI_ADC_DEMO\	TI's ADC-Demo directory
22	ADC_Demoxxx.ZIP	Compressed program file for ADC Demo

LC Display with I²C Bus

multi-purpose and for the MSC1210 board

Design by J. Wickenhäuser

www.wickenhaeuser.com

Okay, your microcontroller program is finished and now you want to see some text and other stuff on a display. Unfortunately, the LCD you happen to have available seems to take up rather a lot of precious port pins. Even worse, the driver you've been able to unearth from a software archive seems to rely on other port pins than the ones you had in mind...

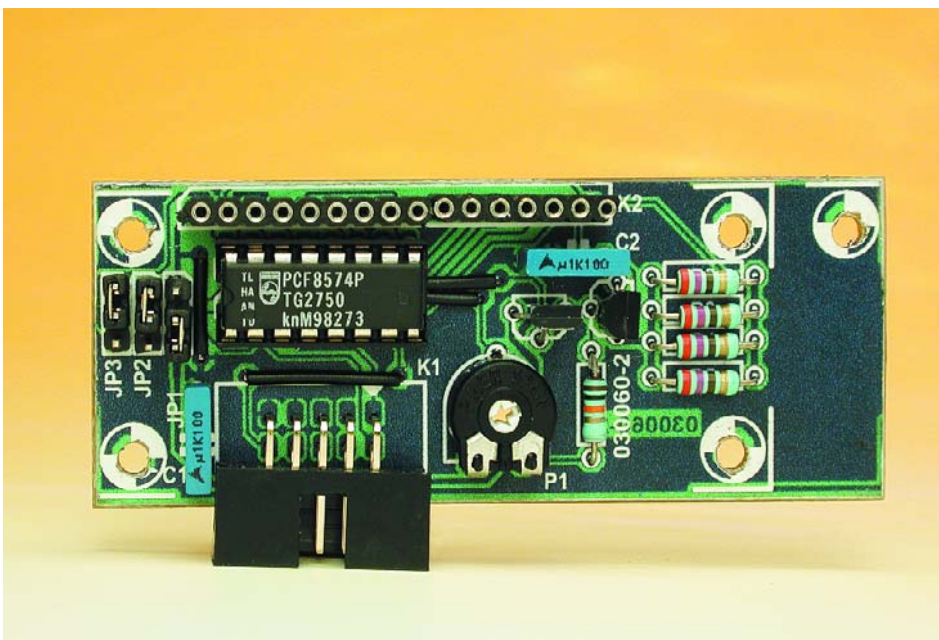

Usually, a lot of hard work has been done, including the mental digestion of piles of datasheets, before the first 'Hello World' message appears on your microcontroller system display. We propose an end to this rather wasteful process by describing a universally applicable LC display with a nice set of features, employing the I²C bus which translates

in the use of just 2 (say, two) of the precious port pins on your microcontroller. Admittedly the small printed circuit needed for the universal LCD board represents extra hardware, but you'll soon find that it's well worth the investment.

Clearly this article should discuss

not only hardware, but also software, and that comes in the form of a complete driver (8051 ANSI C source code) which allows you to employ the `lcd_printf()` function without any restrictions. The driver proposed here even allows the outputting of floating point numbers and numbers in larger sizes.

The display solution discussed in this article is especially well suited to battery-operated equipment because the display can be put to sleep by software, reducing its current consumption to just a few micro-amps. Besides, it is possible to set the LCD's I²C address with the aid of a few jumpers (or wire links). Using three jumpers and two available IC variants, up to 16 of these LCD units may be connected to a single I²C bus.

Of course it is possible to omit the LCD and use the board as a simple I²C bus port. That would allow you to connect, for example, a 3 × 4 matrix keypad or a relay driver/interface. However such alternative uses of the board are only discussed in general terms, see the 'PCF8574' inset.

Remote 8-bit I/O expander for the I²C bus

The 10-way boxheader on the board has the same pinning as that on the Precision Measurement Central ('Elektor Meter') board described in the July/August 2003 issue of this magazine. Here, the industry-standard PCF8574 is used as an interface between the LCD and the signals on the I²C bus. The base address of the chip is preset using three jumpers. The default address is # 66 (see 'PCF8574' inset). The display can be just about any alphanumeric type you may have available, as long as it is HD44780 compatible. However, the pins used for the LCD supply and backlighting (if available) should be checked carefully as they may differ between manufacturers.

The board was designed to fit under most commonly found LC display sizes, in particular, those of the 4 × 20 character type. However, smaller types may also be connected without problems. In case of doubt, only the first line of the display may be shown. The display and the board should be secured to one another using PCB spacers. The electrical connection is by short wires.

The display can be switched off by software, which has a nice side-effect in that the display is reset at the same time (which may be necessary every now and then!). The display is operated in 4-bit mode.

The uC/51-ANSI-C Compiler (for all 8051 compatible micros) discussed in parts 1 and 2 of the Precision Measurement Central article may also be used to control the display. All drivers are supplied in the form of source code files, hence need no further discussion here. The compiler and the source code files may be obtained from the Free Downloads section of the *Elektor Electronics* website. The driver itself is pretty compact and requires a minimum amount of memory to work.

On each LC display connected to the bus, up to eight characters can be user-defined, and the driver will initialise them as a substitute for a 7-segment display. The same drivers should also enable you to extend the functionality of the display to your own requirements. A weblink to an

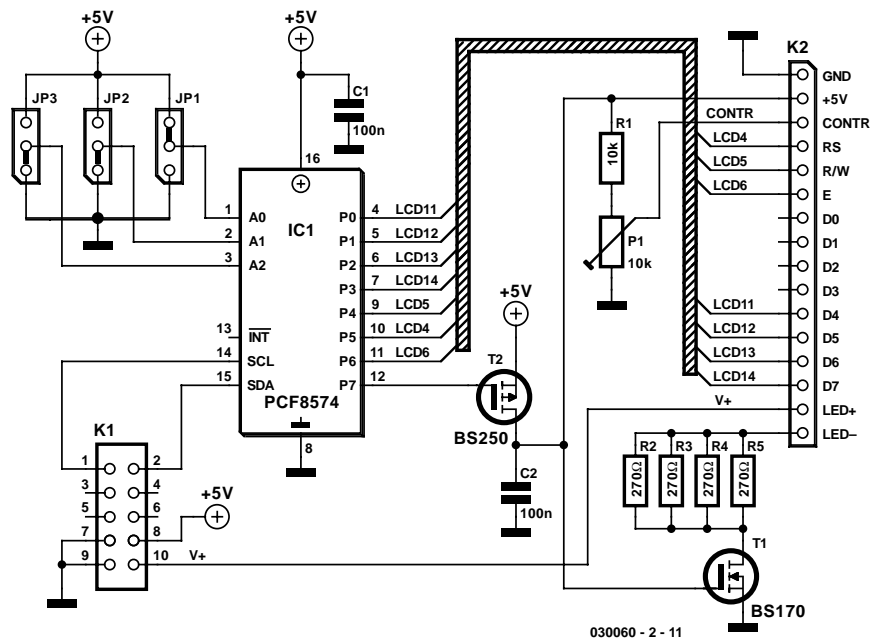

Figure 1. Circuit diagram of the I²C LCD interface.

interesting generator project is included at the end of the article. One rather playful option is to

change the character set during operation — try it for some visually interesting effects like animations.

PCF8574 8-bit I/O Expander for I²C Bus

Elektor Electronics readers know the I²C bus from many projects published in books as well as the magazine, so a discussion of the I²C standard is probably not required here. The PCF8574 offers eight bi-directional, digital, I/O pins. The structure of the individual port pins is hardly different from that of the industry-standard 8051 processor. Simplifying things to some extent, both are 'open drain' lines with weak pull-up resistors. Just as with the 8051, an input may only be read if the relevant port pin has been set to '1' before. The PCF8574 has three address inputs, A0, A1 and A2, which allow up to eight PCF8574's to be connected up to a single I²C bus. There is also a PCF8574A variant which has a different base address. This means that the total number of individually addressable I/O expanders is 16.

Naturally the PCF8574(A) is also perfect for other applications like driving relays or scanning (keyboard) switches.

The addressing follows this structure:

0 1 0 0 A2 A1 A0 0

for the PCF8574 (base address = 64), and

0 1 1 1 A2 A1 A0 0

for the PCF8574A (base address = 112)

The bits for A2, A1 and A0 correspond to the logic levels on the IC pins: '0' for GND and '1' for Vcc.

In the Precision Measurement Central, the I²C address '66' (decimal) is used. So, on the LCD board, jumper 1 should be connected to +5 V (logic level '1') and jumpers 2 and 3, to ground (logic level '0'). The address used is found in the program `LCD_I2C.c`. All activity on the SCL and SDA lines is caused by as well as taken care of by a library (complete with source code texts) that comes with the uC/51 Compiler. Other I²C devices are equally simple to talk or listen to. The library was developed with great care and was found worth its salt in many an industrial application.

Three-layer software

The software written for this project operates at three levels (or layers). At the top level we find the user module. The next lower level is an intermediate module that copies characters to a low-level driver. The driver is also suitable for a direct 4-bit or 8-bit connection to the CPU. To stay within the scope envisaged for this article, only those functions are discussed that are visible to the user. The main functions are:

lcd_init()

initialises the display and activates the oversized numbers in the character set. If everything is okay, a '0' is returned.

lcd_printf()

employs the same parameters as the regular `printf()` command. Return value is the number of characters supplied to the LCD.

lcd_putc()

outputs a single character (like `putc()`).

lcd_cgchars()

copies a 64-byte block into the display character memory. This memory may be located in external RAM or in the microcontroller's program memory.

lcd_d2_printf()

As `printf()`, only all numbers are displayed 'oversized'.

All functions are employed in the demo programs for the Elektor Meter documentation

and described there.

Finally, a few words on timing. Obviously, you will want to be able to use the bus at the highest possible speed. Consequently the software has to be informed about the speed of the controller you are using. In the uC/51 Compiler, that is done using the `CPU_NSEC` macro which indicates the effective time (in nanoseconds) spent on a single CPU instruction. In most cases, this will equate to the average instruction time.

If no display is available, all output is into cyberspace, i.e., goes to waste. Whatever happens, the driver will not remain stuck somewhere, but returns to the main software within a certain time.

The printed circuit board

The *Elektor Electronics* laboratory design for a printed circuit board is

Web links

www.wickenhaeuser.com
Author's homepage. Downloads for ANSI Compiler and drivers.

www.erikbuchmann.de
Javascript generator.

www.lcd-module.com
Many LCD datasheets.

given in **Figure 2**. The board may be obtained from The PCBShop under number **030060-2**. As opposed to a SMD version designed by the author, the Elektor board is stuffed with leaded components only. Please note that there are four wire links which should not be forgotten

(030060-2)

COMPONENTS LIST

Resistors:

R1 = 10kΩ
R2-R5 = 270Ω
P1 = 10kΩ preset

Capacitors:

C1, C2 = 100nF

Semiconductors:

T1 = BS170
T2 = BS250
IC1 = PCF8574(A)P

Miscellaneous:

JP1, JP2, JP3 = 3-way pinheader with jumper (or wire links) (JP1 to +; JP2 and JP3 to ground)
K1 = 10-way boxheader, angled solder pins
PCB, order code **030060-2** from The PCBShop

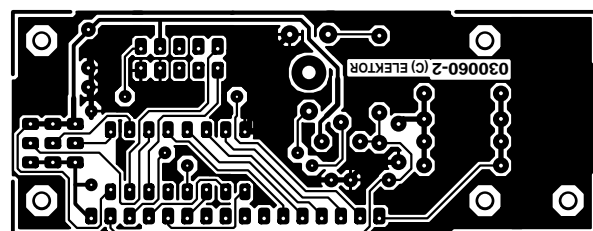
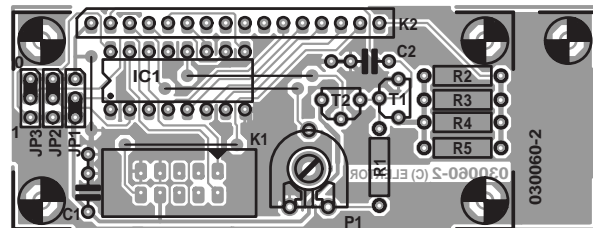
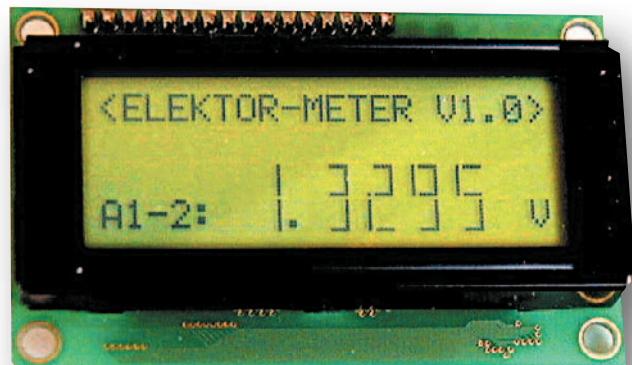

Figure 2. Layout of the single-sided printed circuit board.

ATV Picture Generator

With high resolution

Design by G. Koskamp, PEISCD

g.koskamp@planet.nl

This test chart generator was originally designed to display high-resolution pictures on amateur television (ATV) for station identification, but of course it can also be used to generate any other test pattern. These can be downloaded into the generator using the serial port on a computer.

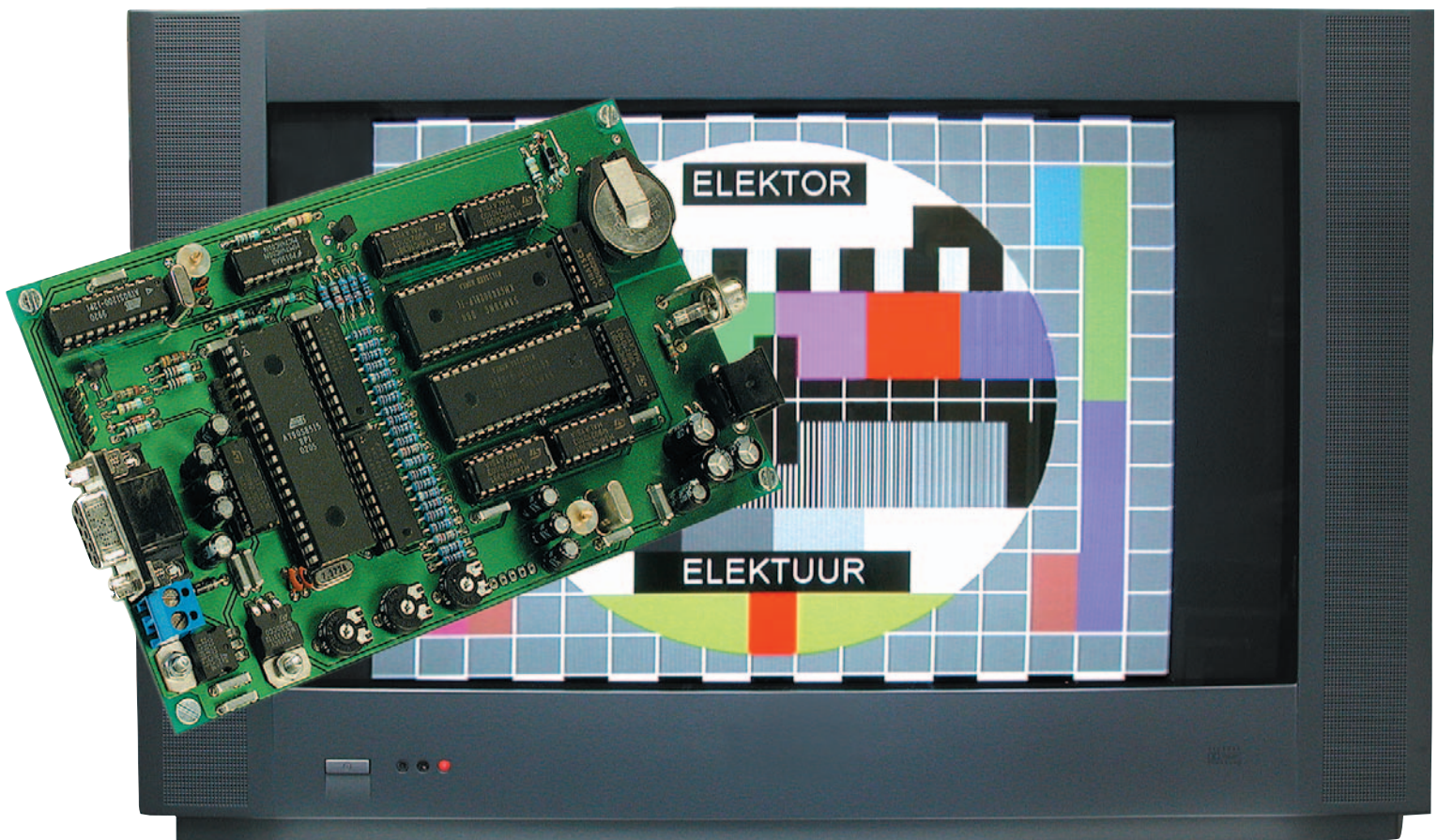

From the above description, you can gather that this is a general-purpose circuit. The only restriction of the test chart generator is that it only has limited support for generating multi-burst signals.

The generator has a resolution of 625×576 pixels in high-resolution mode and 625×288 pixels in low-resolution mode with 32768 colours. The PC image-loader program automatically scales the image to one of these resolutions. Since these aren't quite the correct screen proportions, the program assumes that a resolution of 720×576 pixels has the right proportions. If you want to make an image fill the screen completely it therefore has to be at a resolution of 720×576 . When an image with a different resolution is loaded it will appear with black bars at the top and bottom, or at both sides.

Two programmed processors have been used in this circuit. These can be obtained ready-programmed from *Elektor Electronics Readers Services*, or the software can be downloaded from www.elektor-electronics.co.uk.

Operation

Since this is a sizeable circuit, we have made a block diagram (see **Figure 1**), where all the different functional blocks are easily recognisable. The IC numbers within the blocks refer to the relevant components in the main circuit diagram. It would help if you refer back to the block diagram during the following description of the circuit, as it makes it easier to understand how everything fits together. The full circuit diagram of the generator is shown in **Figure 2**.

The image to be displayed is stored in two $512 \text{ kB} \times 8$ SRAM chips (IC1, IC2). Every pair of bytes corresponds to one pixel and to display the image the complete memory contents are output using an 18-bit synchronous counter, constructed around IC9 to IC13. Address line A18 is used to select one of the two images in low-resolution mode; in the high-resolution mode it is used to select the odd or even lines.

The names of the addresses from the SRAM chips don't correspond with those from the address bus.

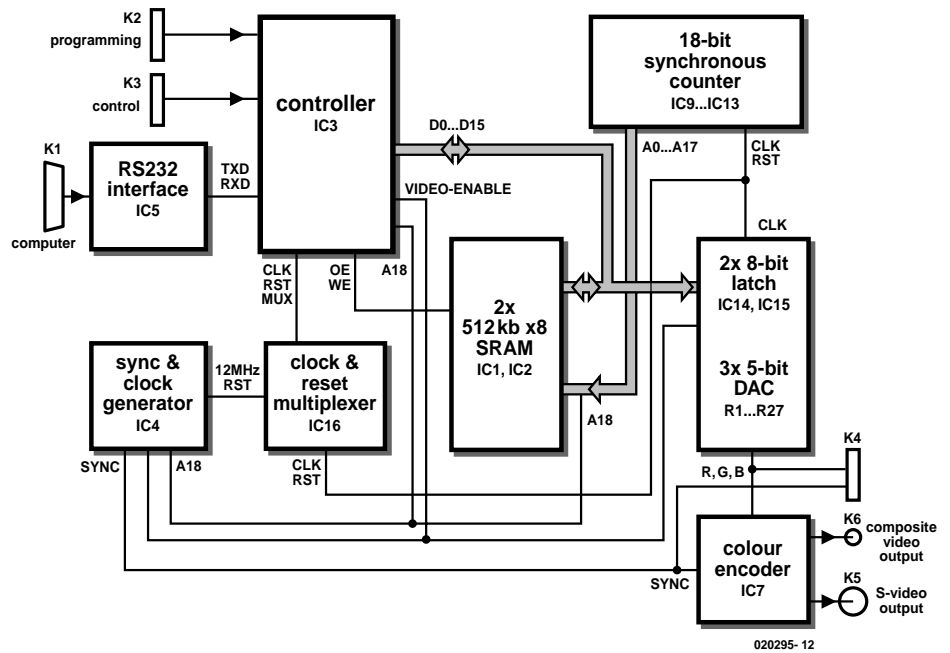

Figure 1. This block diagram makes it easier to understand the set-up of the hardware.

That was done in the design stage because it resulted in a simpler PCB layout, but it makes no difference to the operation of the SRAM chips.

The data lines of the SRAM chips are fed to a pair of latches (IC14 and IC15). These latches turn off the video signal momentarily during the generation of a synchronisation pulse or when an image is loaded. The latches also make sure that all bits of a pixel are presented to the three D/A converters (R1 to R27) at the same time. Finally, the latches make sure that the digital outputs have voltages of 0 V or 5 V (not all memory chips are capable of this). In this case that really is a necessity because the D/A converters are created with resistors. Resistors R1 to R9 are for the D/A converter of the red signal, R10 to R18 are for the D/A converter of the green signal and R19 to R27 are for the D/A converter of the blue signal. The level of these three analogue signals can be adjusted with presets P1 to P3. These signals are then made available on connector K4, along with the synchronisation pulses. This connector can be used to connect an external colour encoder or a buffer stage, so that the RGB signals can then be connected directly to the TV. The RGB signals and the synchronisation pulses are also fed to colour

encoder IC7. This IC converts them into a composite video signal as well as an S-video signal.

The synchronisation pulses and a few other signals, such as the A18 address line, are generated by microcontroller IC4. This solution turned out to be cheaper than using a dedicated 'synchronisation IC'. The 12 MHz clock for IC4 is also used by counters IC9 to IC13 for counting the pixels.

Microcontroller IC3 controls the whole generator and also takes care of the downloading of images. During normal operation (that is, when an image is displayed) this microcontroller does little more than looking what happens on the serial port and if the push-button on connector K3 is pressed. Connector K2 is also connected directly to the microcontroller. This connector can be used for any future expansion or for the (re)programming of the microcontroller.

When an image has to be downloaded, microcontroller IC3 turns off latches IC14 and IC15, and takes complete control of counters IC9 to IC13. The pixels are then stored into the SRAM one by one via the data bus. Once all pixels have been stored, the counters are freed up again and the latches are enabled; the new image will now appear on the screen.

A few other components are required for the correct operation of the test chart generator. IC5 is an RS232 driver and is responsible for the level shifting that is required between CMOS and RS232 signals. IC16 takes care of the switching of the clock and

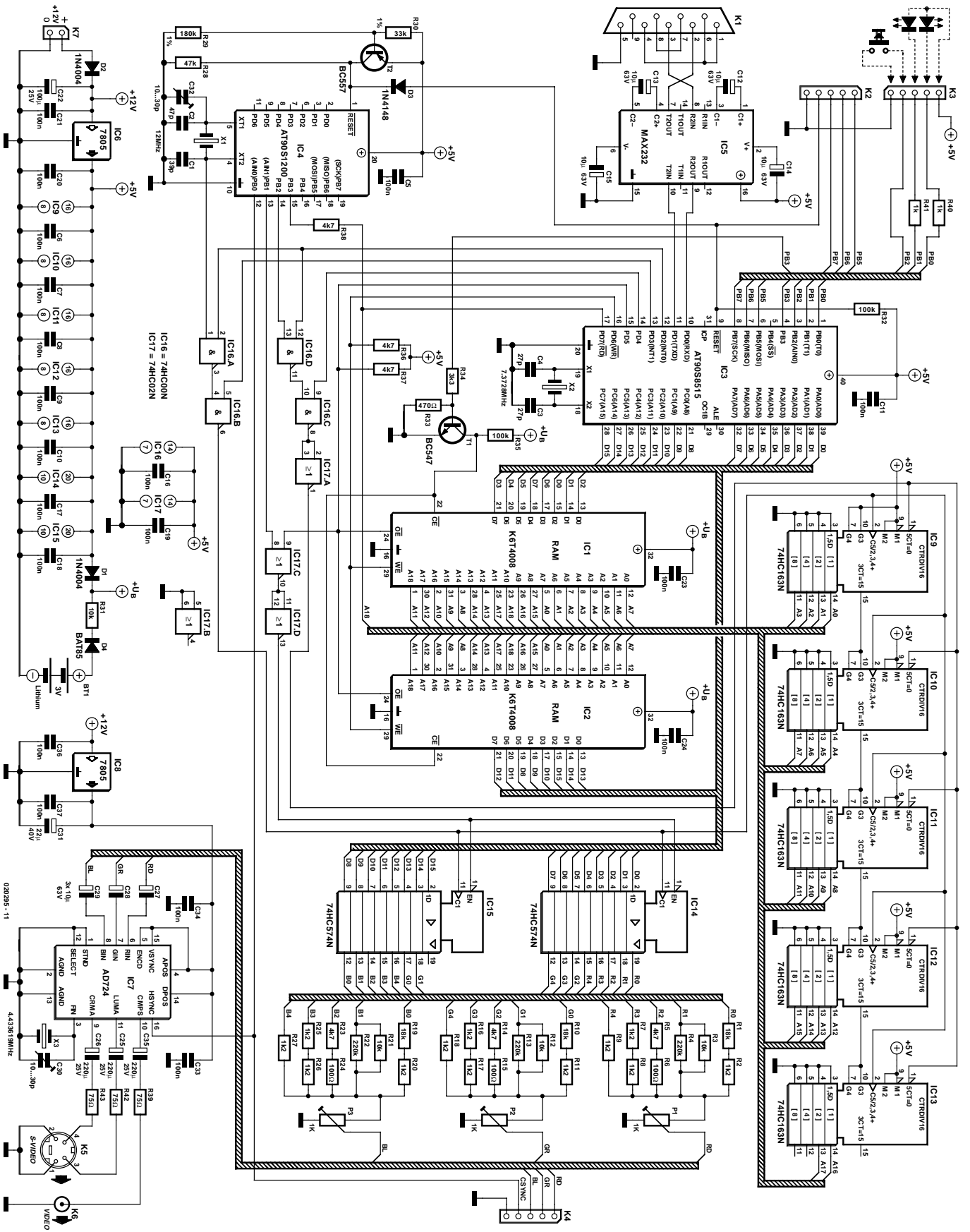

Figure 2. The complete circuit diagram of the test chart generator. The LEDs and push-button connected to K3 are the only parts of the user-interface.

reset signals for the counters. The circuit round T1 sets the \overline{CE} pin of the SRAM chips 'high' when there is no supply voltage present at the test chart generator. In that case the SRAM chips go in their standby mode, which lowers their current consumption considerably, making it possible to use a backup button-cell (BT1) for their supply; the stored image is therefore retained. Transistor T1 doesn't check the supply voltage, but is driven directly by the microcontroller and is only turned on when the supply voltage to the test chart generator has been stable for

a few hundred milliseconds.

The circuit round T2 turns off the microcontrollers when the supply voltage becomes too low. The power supply stage consists of two 5 V voltage regulators (IC6 and IC8) and a handful of decoupling capacitors. The colour encoder has its own voltage regulator, making it less susceptible to interference from the digital section, therefore producing a better output signal.

Diode D1 prevents the circuit from being powered by backup battery BT1 when there is no supply voltage present. Resistor R31 functions as a

current limiter for BT1 and diode D4 prevents a charging current from flowing into the battery from IC6. Diode D2 is added for reverse-polarity protection, so that the whole circuit won't be blown up if the supply is accidentally connected the wrong way round.

Construction and calibration

Populating the PCB shown in **Figure 3** will obviously take a fair amount of time, but it isn't very difficult.

It is best to start with the supply section, then connect a 12 V mains adaptor and check that voltage regulators IC6 and IC8 provide a clean 5 V. The other components can be

Generating the synchronisation signals

The generation of the synchronisation signals (often shortened to 'sync signals') takes place in an AT90S1200 microcontroller. This works at a clock frequency of 12 MHz and can process almost 12 million instructions per second. This throughput makes it highly suitable for use as a sync signal generator. These signals have to be generated fairly accurately, but first we'll explain in detail what sync pulses are and what they look like.

A PAL-standard TV signal has 625 lines per frame, which is repeated 25 times per second. Since a picture that is repeated 25 x per second would appear to flicker severely, a little trick is used to make it appear on the TV screen 50 x per second. The complete picture is split into two half-frames. First all the odd lines are shown and then all the even lines.

If we display 625 lines 25 x per second that corresponds to 15,625 lines per second. One line therefore has a duration of 64 μ s. Each line requires a synchronisation-pulse to make it appear neatly on the screen. This sync-pulse has a width of about 4.7 μ s; after this is a bit of nothing, which is followed by the picture information for that line. These pulses at the beginning of each line are called **horizontal synchronisation pulses** (see **Figure A**).

Because the TV also has to know when to start from the top of the screen, there is a requirement for **vertical synchronisation pulses**. The pulses are a bit more complex and appear every 312.5 lines. The vertical sync pulses take up 7.5 lines each time, and these lines can therefore not contain any picture information (see **Figure B**).

Several types of pulses are used in the vertical sync signal. In **Figure B** two types can be seen. The first is low for 27.3 μ s and then high for 4.7 μ s. The second is low for 2.4 μ s and high for 29.6 μ s.

One of the 8-bit internal counters of the microcontroller has been used to help the software generate the sync pulses at just the right time. It generates an interrupt every 16 μ s and the program uses it every other time, so that a small routine runs every 32 μ s.

The program (refer to the source code 020295-11, which is available on floppy disk or from www.elektor-electronics.co.uk) counts in so-called half-lines, of which there are four types. Line type 0 is a line where nothing happens to the sync signal. Type 1 is a line where there is a 'low' pulse of 4.7 μ s for the horizontal sync. In type 2 there is a 'low' pulse of 2.4 μ s for the vertical sync. Type 3 is a line with a 'low' pulse of 27.3 μ s and is also used for the vertical sync. During every line the program prepares for the next line and starts from the beginning again after 1250 half-lines.

The microcontroller also outputs a signal that indicates odd or even lines. This signal is used by the test chart generator to display high-resolution images. When this signal is ignored, the generator works in its half-resolution mode and the odd and even lines will contain the same information. The microcontroller also makes sure that no image information can overwrite the sync pulses. So even when there is something wrong with the SRAM contents, the sync pulses will not be affected.

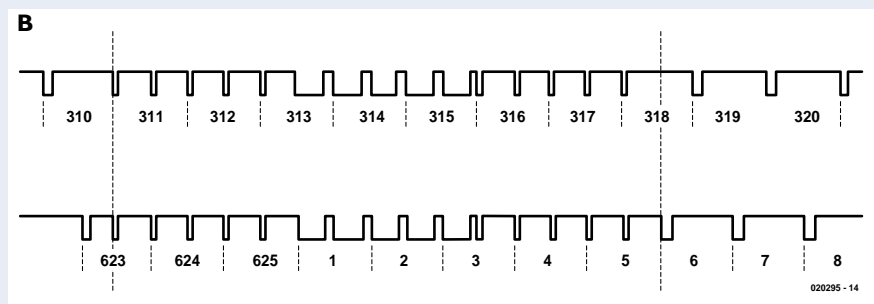
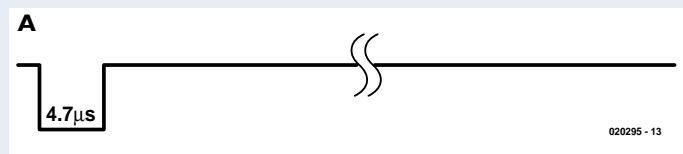

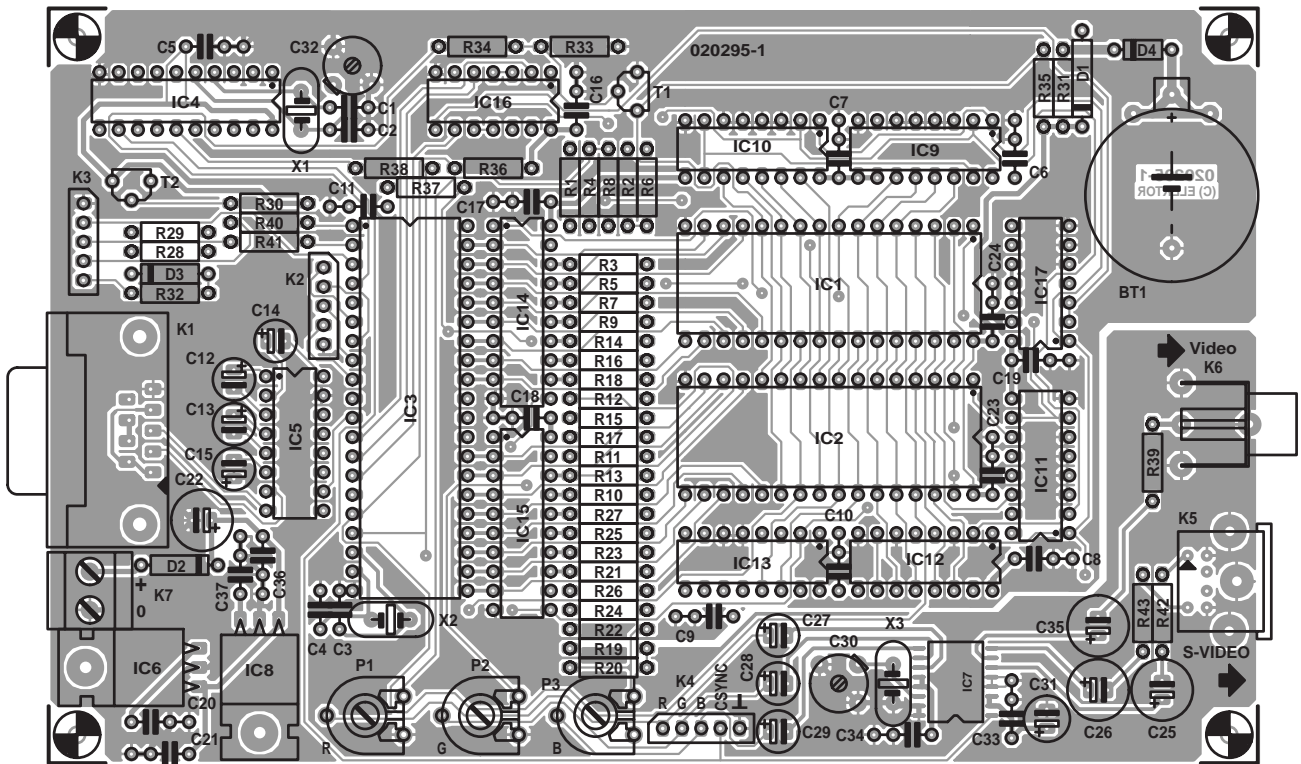

Figure 3. Despite the size of the circuit, this sophisticated PCB guarantees a straightforward construction.

COMPONENTS LIST

Resistors:

R1,R10,R19 = 18k Ω
 R2,R7,R8,R9,R11,R16,R17,R18,R20,R25,R26,R27 = 1k Ω
 R3,R12,R21,R31 = 10k Ω
 R4,R13,R22 = 220k Ω
 R5,R14,R23,R36,R37,R38 = 4k Ω
 R6,R15,R24 = 100 Ω
 R28 = 47k Ω
 R29 = 180k Ω 1%
 R30 = 33k Ω 1%
 R32,R35 = 100k Ω
 R33 = 470 Ω
 R34 = 3k Ω
 R39,R42,R43 = 75 Ω
 R40,R41 = 1k Ω
 P1,P2,P3 = 1 Ω k preset

Capacitors:

C1 = 39pF
 C2 = 47pF
 C3,C4 = 27pF
 C5-C11,C16-C21,C23,C24,C33,C34,C36,C37 = 100nF
 C12-C15,C27-C29 = 10 μ F 63V radial
 C22 = 100 μ F 25V radial

C25,C26,C35 = 220 μ F 25V radial
 C30,C32 = 10-30pF trimmer
 C31 = 22 μ F 40V radial

Semiconductors:

D1,D2 = 1N4004
 D3 = 1N4148
 D4 = BAT85
 IC1,IC2 = K6T4008C IC-DB70 (CMOS SRAM, 32-DIP, 512k*8, 70ns) (Samsung)
 IC3 = AT90S8515-8PC, programmed, order code **020295-41**
 IC4 = AT90S1200-12PC, programmed, order code **020295-42**
 IC5 = ST232CN (ST) (MAX232 compatible)
 IC6,IC8 = 7805
 IC7 = AD724JR (16-Lead SOIC!) (Analog Devices)
 IC9-IC13 = 74HC163
 IC14,IC15 = 74HC574
 IC16 = 74HC00
 IC17 = 74HC02
 T1 = BC547C
 T2 = BC557B

Miscellaneous:

BT1 = 3V Lithium button cell (e.g., CR2032) with PCB mount holder (dia. 22.75mm)
 K1 = 9-way sub-D socket (female), PCB mount
 K2,K3,K4 = 5-way SIL-pinheader
 K5 = S-VIDEO 4-way or 6-way mini-DIN-socket (female), PCB mount
 K6 = cinch socket, PCB mount, e.g., T-709G (Monacor/Monarch)
 K7 = 2-way PCB terminal block, lead pitch 5mm
 X1 = 12MHz quartz crystal (parallel resonance, $C_{load} = 30$ pF)
 X2 = 7.3728MHz quartz crystal (parallel resonance, $C_{load} = 30$ pF)
 X3 = 4.433619MHz quartz crystal (series resonance, $C_{load} = 30$ pF)
 Not on PCB:
 2 high-efficiency LEDs
 Pushbutton, 1 make contact
 PCB available via ThePCBShop
 Disk, PC software, source- & hex-code: order code **020295-11** or Free Download

mounted after that. Presets P1, P2 and P3 should be set to about one third of their range. The lithium button cell should only be

put in its holder once the whole circuit functions properly. **Figure 4** shows a photo of the completed

PCB. **Figure 5** shows a close-up of SMD IC7, which is mounted on the solder side of the PCB.

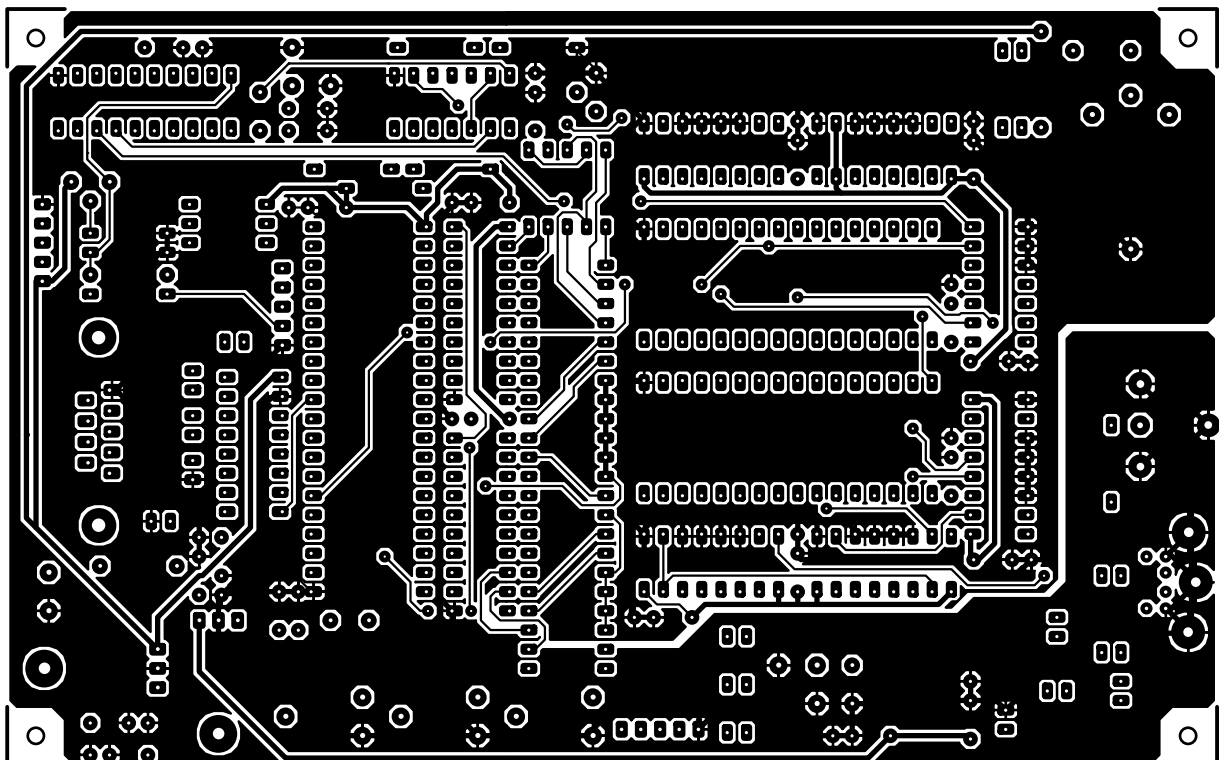
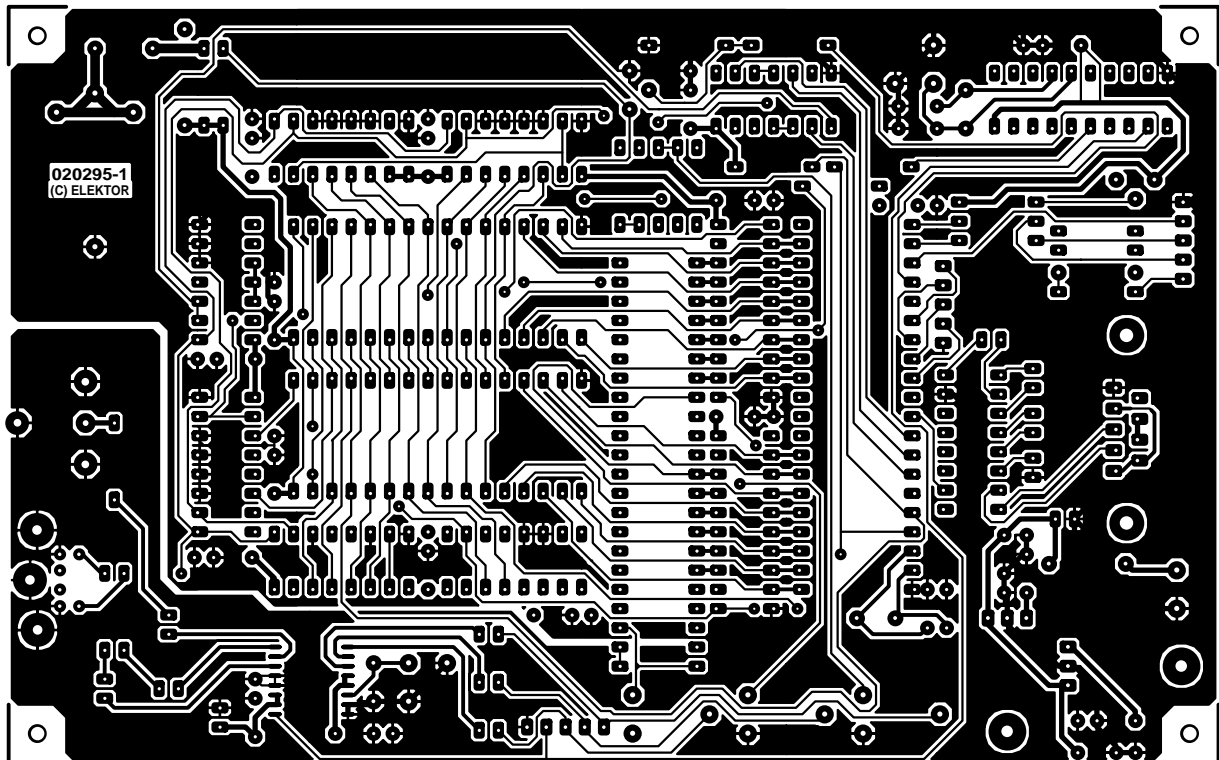

The circuit round crystal X1 deserves more attention. It is possible that the crystal cannot be adjusted to exactly 12 MHz. When that is the case, the value of C2 could be lowered to, for example, 39 pF or 27 pF. If the frequency is

not exactly 12 MHz then the values given in the circuit will be fine since the deviation will only be about 100 to 200 Hz at most.

When the complete circuit has been carefully built and the 12 MHz oscillator has been correctly

adjusted, the two LEDs and a push-button should be connected to connector K3 as shown in Figure 2. When the supply is connected, one or two of the LEDs should be lit. The test chart generator should then be set to its test-mode by holding down the push-button for a few seconds. When the test chart

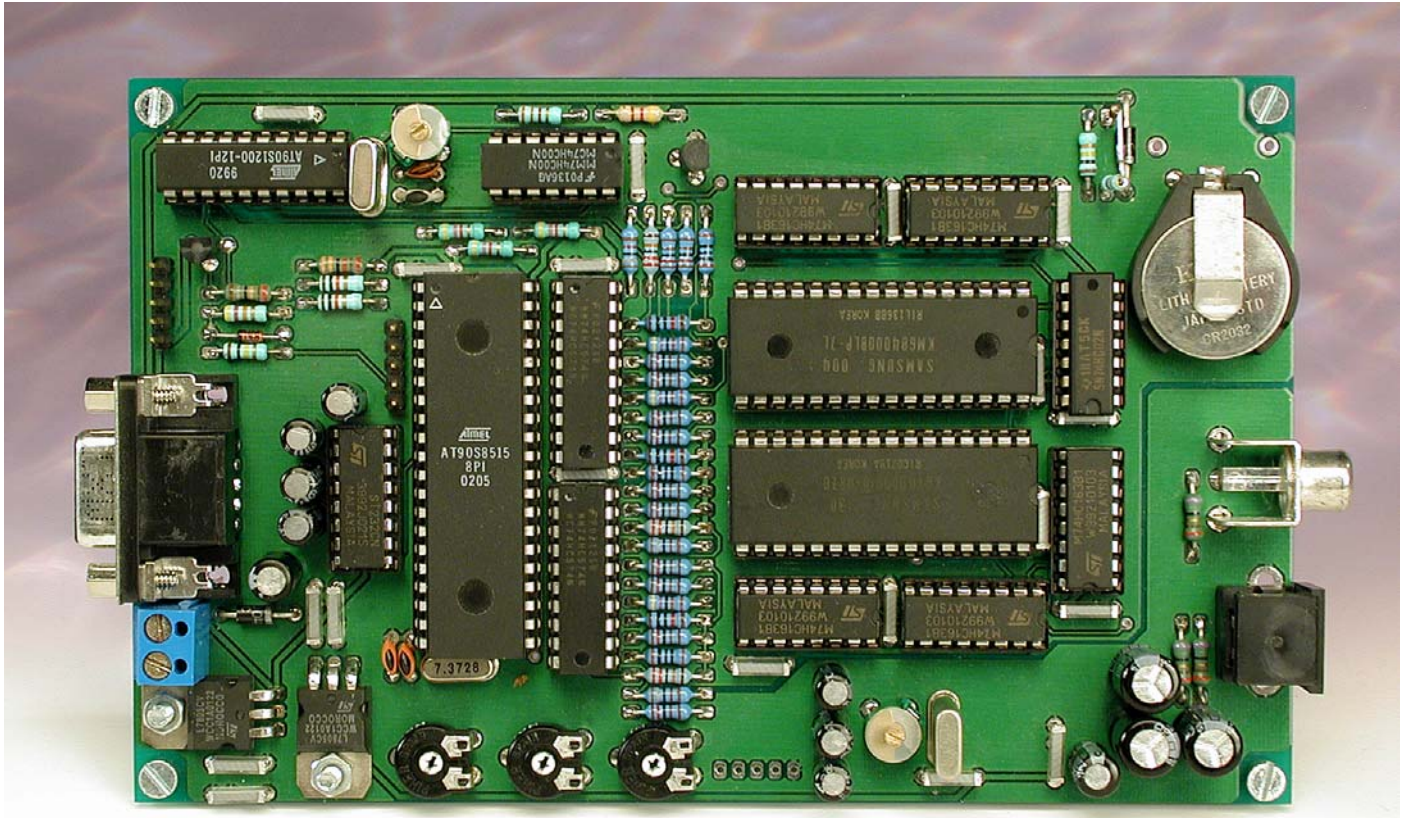

Figure 4. Photo of the fully populated PCB.

generator switches into test-mode, the LEDs will light up alternately for a while and settle with just one lit up.

A TV can now be connected to the output. This should show, assuming everything is in order, some colour bars, greyscales or a mixture of the two. If the screen shows a mixture of colour bars and grey scales, trimmer C30 needs to be adjusted until a stable colour picture appears. At this stage the colours may still appear a bit strange, but for this we have to adjust presets P1, P2 and P3. The easiest way to do this is to connect an oscilloscope to the composite video output, without any other load being present. The test chart generator now has to be set to the greyscale mode by pressing the push-button once more. The oscilloscope should now show a staircase signal within the video signal, with a line that probably becomes thicker as the level rises (that is the colour subcarrier). Presets P1, P2 and P3 should now be adjusted until the signal has a level of $2 V_{pp}$, from the lowest level of the synchronisation pulse to the top of the video signal. The synchronisation pulse should be about 600 mV and the video signal about 1400 mV. The colour subcarrier should hardly be present, so the line on the oscilloscope should be as narrow as possible.

Following on, trimmer C30 can then be adjusted for a better picture, but this isn't as simple as it appears because it isn't possible to connect a probe directly to X3 or C30. This would cause the frequency to drift or the oscillator to stop altogether. A better solution is to take the measurement from the colour decoder in the TV. This will be locked to the frequency of X3, or a multiple thereof.

When the adjustments are complete, the battery may be inserted. When the power supply is turned on the voltage at the collector of T1 should be close to 0 V. When the power supply is then turned off, the collector voltage should rise to about 3 V (the battery voltage). It is important to verify this because if the voltage stays at 0 V the SRAM ICs will not go into standby mode and the battery will drain much more quickly.

Software

The software for uploading the (test) patterns has been kept very

simple (**Figure 6**) and can only deal with pictures in BMP or JPG formats. Under the 'Mode' option in the menu you can choose between high and half resolution. At half resolution there is a choice of two images because two of them can fit in the memory of the test chart generator. When two of them have been loaded into memory, a push-button can be used to switch between them. When loading an image, the program automatically scales them so they fill the largest possible area on the TV screen. It is of course necessary to select the correct COM port on the PC, which is connected to the test chart generator.

Programming

The test chart generator is controlled via the serial port using a simple protocol. For those of you who would like to experiment with this yourselves, there follows a summary of the commands that the generator accepts on its serial port. The com-

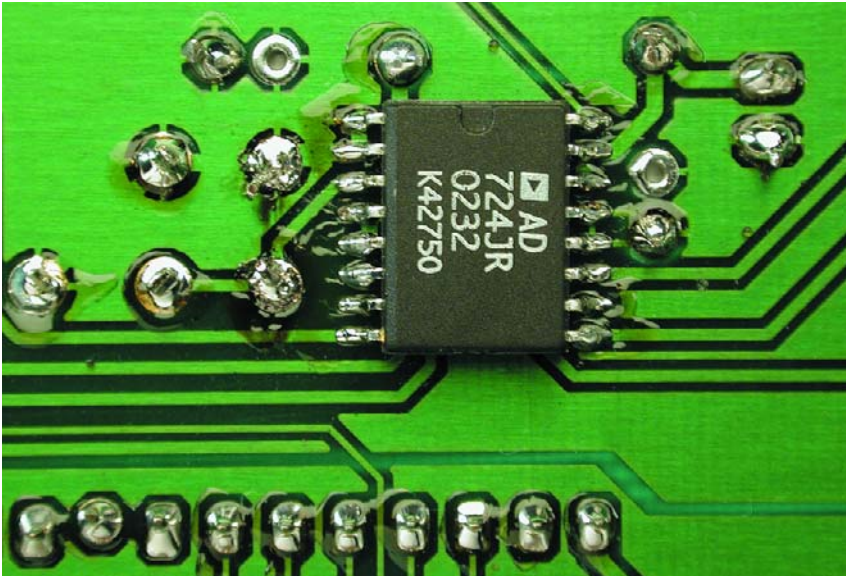

Figure 5. A close-up of SMD IC7, which is on the solder side of the PCB.

munication settings are as follows: 15200 baud, 8 data bits, 1 stop bit and no parity. The string 'VGENOPEN' has to be sent first to set the test chart generator into 'command' mode, when it will be able to accept commands.

Commands:

HEX-code	Function
00h	Following this command, 128 uncompressed pixels have to be sent to the test chart generator. Each pixel consists of 2 bytes, so 256 bytes have to be

sent in total.

- 01h** Following this command, 128 compressed pixels have to be sent to the test chart generator. The compression is realised by first sending the number of pixels concerned (maximum of 128), followed by the two pixel bytes.
- 02h** Turns the video output off and sets the circuit into 'load' mode. This command always has to be sent before using the 00h and 01h commands.
- 03h** Turns the video output on again. After this command you may not send 00h or 01h commands.
- 04h** Resets the counter. The counter has to be reset before any picture information is sent because this ensures that the storage of information will start at the top of the screen.
- 05h** Sets pin PD7 of IC3 as an output and turns it 'low'.
- 06h** Sets pin PD7 of IC3 as an output and turns it 'high'.
- 07h** Sets PD7 of IC3 to its high-impedance state.
- 08h** Stores the setting of PD7 in the internal EEPROM.
- F0h** Returns the software version in the test chart generator.
- FF** Exits from the command-mode.

A pixel consists of two bytes that determine the colour of the pixel. The table below shows how the bits are used in these two bytes.

Bit no.	7	6	5	4	3	2	1	0
Byte 1	G4	G3	G2	R4	R3	R2	R1	R0
Byte 2	-	G1	G0	B4	B3	B2	B1	B0

There is room for 768 pixels on every picture line, of which about 625 are visible. A number of black pixels should therefore be added to the beginning and end of the line. When a complete line has been stored, the next one is automatically selected.

Commands 05h, 06h and 07h are used in the display mode to select one of the half-resolution images, by setting PD7 'high' or 'low'. When PD7 is in a high-impedance state, the high-resolution image will be displayed. In the image-loading mode these commands determine where the images are stored in memory. For half-resolution images it indicates if it is the first or second image and in high-resolution PD7 indicates if it is the odd or even lines that are stored. Command 07h should not be used during the image-loading mode because it would then become uncertain where the information is stored.

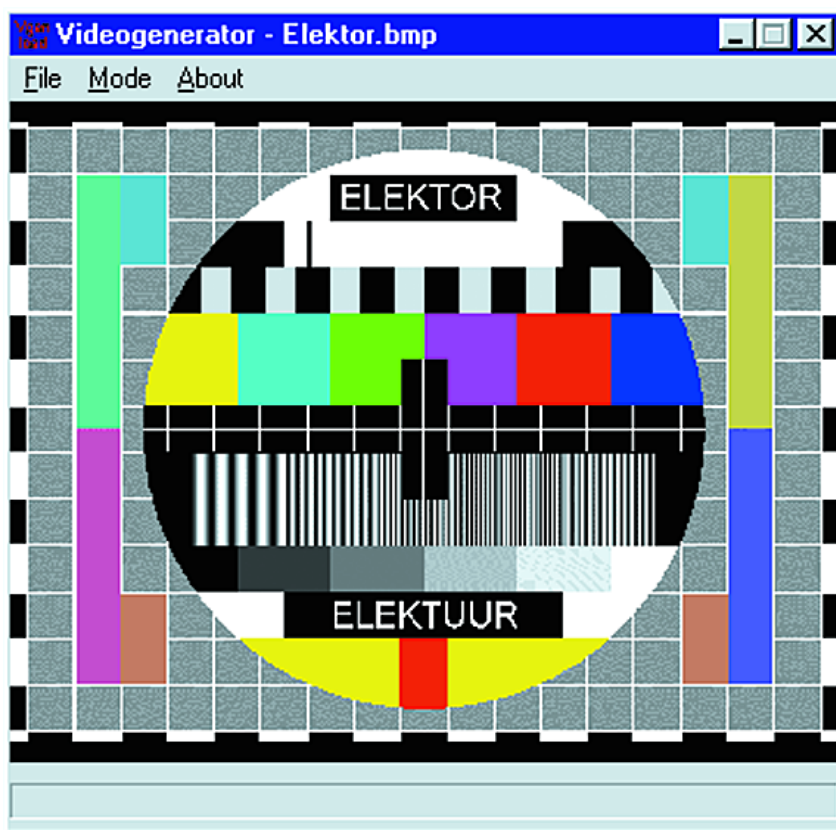

Figure 6. Screenshot of the PC image loader program with a test pattern.

(020295-1)

Connector Data, Please

Connectors, cables & Co.

By Harry Baggen

Communication has become a key aspect of modern society, and the term covers not only communication between people, but also electrical and electronic equipment. In most instances, data exchange is effected via cables and connectors. Fair enough, but as technology progresses, so many different connectors and standards have evolved that it has become difficult to tell them all apart, not even mentioning recognising the shape, functions and pin-outs.

Connector data is indispensable if you want (or need) to make your own connecting cable, or design a circuit that's to be hooked up to

some other piece of equipment. In that case, it's not only essential to know which signals ought to be on

the connector pins, but also their level and function. Are you dealing with an analogue or a digital signal? What is the 'swing' of the digital signal, or, in the case of an analogue signal, what is its impedance and typical level?

Fully aware of the bewildering number of connectors and standards around in today's confused electronics scene, finding the right data may well present a bigger problem than actually buying, using and wiring the connector in question!

Time to call in the help of the Library of Libraries: The Internet. An excellent starting point on the web, we found, is **The Hardware Book** [1], which claims to be the largest freely accessible Internet database covering connector pinouts and cable data. As far as we have been able to ascertain, the claim is justified! The connector pages are conveniently divided into categories including Audio/video, buses, cartridges, extension connectors, tele-

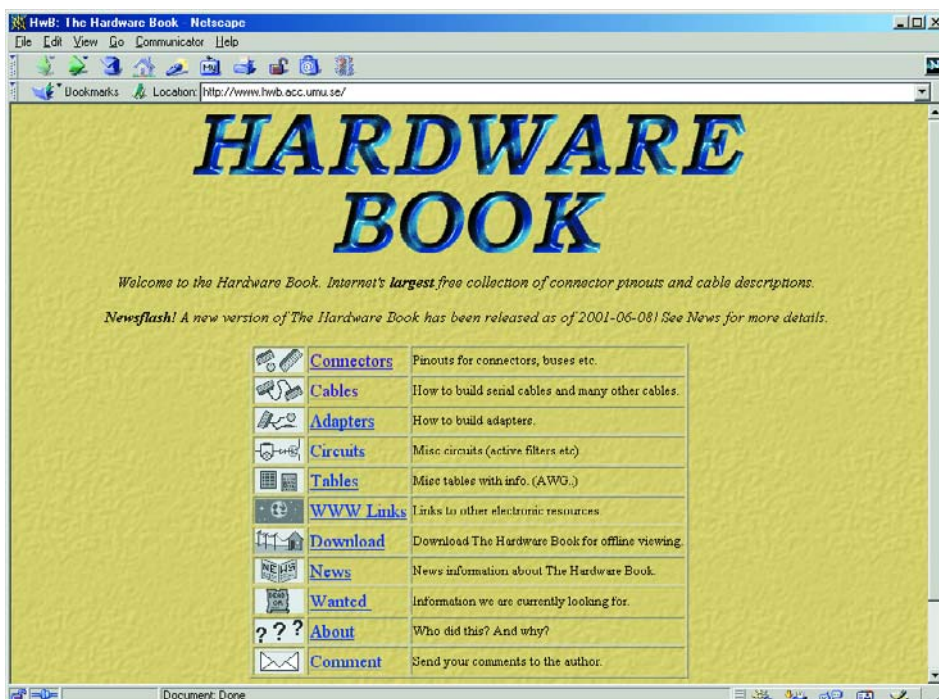



4 Pole AV Connector

(As used on many modern camcorders)

Pin number	Description
1	Left Audio
2	Composite Video
3	A&V Ground
4	Right Audio

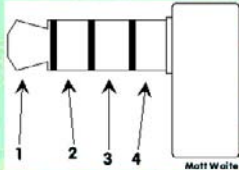

I have had numerous requests for suppliers of this connector, to date the options are as follows:

- Order a 1.5m long 4 pole 'jack to phono's' cable from [CPC](#) (order code AV02142) and cut off any unwanted plugs - a bit messy but a workable solution.
- If you are in the States, you could try [Mouser](#). They appear to stock the plugs on their own (order code 171-7435) (Thanks to Joel for that info)

phony, networks, serial data links, Centronics, mouse, keyboard, IDE, SCI, power supplies. The 'cable' sec-

tion is likewise divided into categories, although the larger part describes computer cabling. The

RCA Interconnects

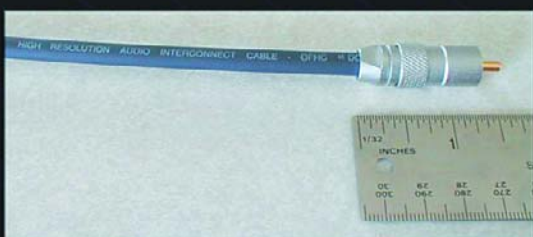

My interconnects are made from MCM connectors [part 60-2130](#) and MCM high resolution audio cable [part 60-2170](#). The cable is also available in 50 and 100 foot lengths, and the connectors are also available in color coded red and black. The connectors are made out of metal with gold plated inserts and are very well built. The cable is 6mm diameter, flexible and heavily shielded.

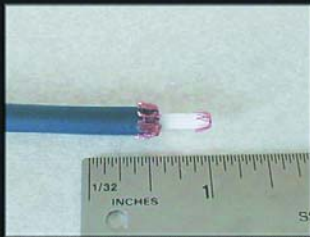

The first step is to strip the wire. Take off about 3/8 inch of the outer insulation and all the outside layer of wire. Be careful not to cut into the inside insulation. Then strip another 3/16 inch of the outer insulation, this time careful not to cut the outer wire beneath it. Then strip about 1/8 inch off in inside insulation, again careful not to cut the wire. Fold the inside wire evenly back. Unbraid the outer wire so no wire overlaps another wire and fold it back, trimming as required to get it even. You should then have a prepped cable as shown above.

Internet Addresses

- [1] The Hardware Book: www.hwb.acc.umu.se/ complete download: www.fbe.fh-frankfurt.de/personal/schellhaas/hwb/hwb.htm
- [2] Elektron-BBS: www.elektron-bbs.de/elektronik/kabel/index.htm
- [3] Contents page: www.elektron-bbs.de/elektronik/kabel/inhalt.htm
- [4] Kabelmax: www.kabelmax.de
- [5] Educypedia: <http://users.pandora.be/educypedia/electronics/cablingaudio.htm>
- [6] Connectivity Knowledge Platform: <http://ckp.made-it.com/>

Hardware Book is also immensely useful as a connector data archive for vintage home computers like the Commodore C64, Sinclair Spectrum, Atari, etc. A big asset of the Hardware Book is the fact that the entire 'book' is available for downloading, allowing users to have a complete 'cable & connector' overview instantly available on the computer.

The German **Elektron-BBS** [2] is a pretty extensive website covering lots of subjects including electronics. The site holds a generous amount of cable and connector data, divided into categories like audio, computer, RF, modelling, telecommunications and video. However, it is judicious to jump straight to the contents page [3] and from there surf to the desired subject. The site will be particularly valued for its data on car connectors and R/C model equipment like servos and ancillaries.

Another website we can recommend is **Kabelmax** [4]. Like the Elektron-BBS, the site is mostly in German, but that should not distract from its usefulness if you are after an elusive connector pinout! Remarkably, the site also contains quite a few circuit diagrams of typically used level-converter circuits (like MIDI-TTL and RS232-TTL). Although the diagrams have been drawn rather crudely (using ASCII symbols), they are still decipherable, while the various tables also provide useful information. Unfortunately, the data on telephone connectors (called TAE) is specific to the German telecommunications market. Some attention is also given to the maximum length of certain types of cable.

In really difficult (i.e. specialist) cases, where only the name of the cable or connector manufacturer is known, the manufacturer's address may be found using Google, entering the manufacturers' name, the word 'connector' and 'address' to narrow down the search results (which may still come in by the thousands).

Other useful web pages, containing, or linking to, very good drawings for audio and video cables and associated connectors, are supplied by **Educypedia** (Educational Encyclopaedia) [5]. The website has much other information to offer on the hobby and is a good point to completely lose yourself in *surfing for electronics, science & IT* on the web!

The **Connectivity Platform** [6] supplies a condensed but clearly organised overview of the majority of digital connections and connectors including serial and parallel links, LAN, WAN and telecomms links. In quite a few cases, you are linked to other websites where supplementary information may be found.

(035053-1)

Over-temperature Alert

A universal alarm circuit

Design by B. Kainka

It's probably the worst nightmare for all PC owners: The fan has been quietly doing its job keeping the PC internals nice and cool but over time the bearing lubricant dries out and friction increases until one fateful morning you turn on the PC and the fan sticks. Now it's only a question of time before something expensive pops. This neat circuit gives a warning when things start to get too hot.

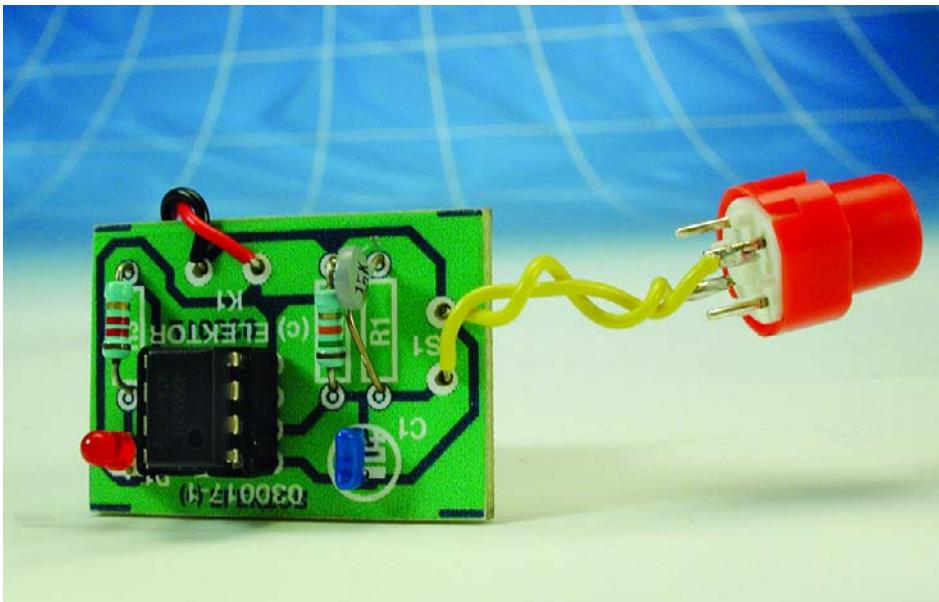

The circuit shown in **Figure 1** uses a simple and economical thermistor as a temperature sensor. The sensor should be insulated and positioned on the PC case. When the temperature exceeds 40° C a warning LED lights or a buzzer sounds or a cooling device can be switched on. The alarm will not be reset

when the temperature dips below 40°C again so it 'stores' any brief over-heating event. Pressing push-button S1 will reset the circuit.

An alarm temperature of 40°C does not seem to be excessively hot when you consider that silicon semi-

conductors can withstand temperatures up to around 150 °C but its important to realise that down at component level the chips are running much hotter so 40 °C is a good compromise. The circuit can be easily modified to cater for different temperature switch levels by substituting a different value resistor for R2. Alternatively a pre-set variable resistor can be used in place of R2 to make the alarm temperature adjustable.

The value of R2 is dependant on the thermistor resistance at the desired alarm temperature. The NTC (Negative Temperature Coefficient) thermistor has a resistance of 10 kΩ at 25 °C and its resistance falls as the temperature increases so that at 40 °C its resistance is 5 kΩ. At this value of resistance the alarm will be triggered. The simple rule is that the alarm will be triggered when the thermistor resistance falls to half the value of R2. If you know the resistance of the thermistor at the alarm temperature then it's a simple process to work out the value of R2.

Table 1 will help in selecting the correct value. The circuit can also be used as a 'freezer fail' alarm so negative temperatures are also given. It is also possible to use a different type of NTC thermistor. The relationship between R1 and R2 will remain the same so that if for example you have a 4.7 kΩ NTC then the value of R2 will need to be changed to 4.7 kΩ to give an alarm temperature of 40 °C.

The circuit

The low power CMOS version of the popular 555 timer chip is used in this design. Internally this chip contains two comparators that switch when the input voltage as at 1/3 and 2/3 of the supply voltage and these outputs control an RS-type flip flop (Figure 2). When the 555 timer is configured as a monostable or astable multivibrator a timing capacitor is used and the voltage across the capacitor swings between these two thresholds. Capacitor C1 generates a reset to the timer when power to the cir-

cuit is first connected. When the sensor temperature reaches 40 °C its resistance has fallen to 5 kΩ and the voltage at the sense input will be at the threshold of 2/3 of the supply voltage so the alarm will sound. The alarm can be turned off by pressing the reset button or will be automatically reset when the sense voltage drops below 1/3 of the supply voltage. With the circuit values shown here giving an alarm temperature of 40 °C this occurs when the temperature has fallen to about +10 °C, corresponding to an increase of the thermistor resistance to 20 kΩ.

The circuit can be built on the PCB shown in Figure 3. The artwork files can be downloaded from this month's Free Downloads at www.elektor-electronics.co.uk. Fitting the components to the PCB should present no problems.

(030017-1)

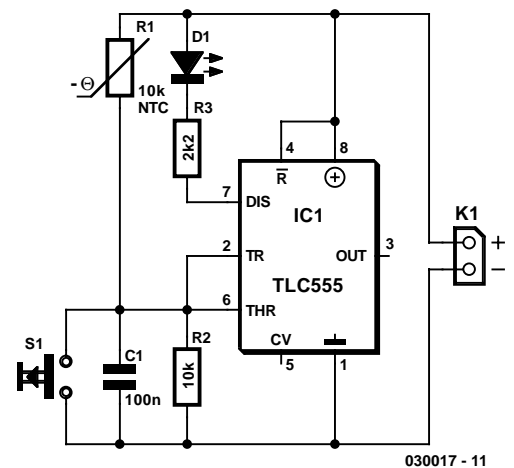

Figure 1. The circuit diagram.



Figure 3. A mini PCB for this mini circuit.

Temperature	Thermistor resistance	Required value for R2
-20 °C	130 kΩ	270 kΩ
-10 °C	68 kΩ	130 kΩ
0 °C	37 kΩ	75 kΩ
+10 °C	21 kΩ	43 kΩ
+20 °C	13 kΩ	27 kΩ
+25 °C	10 kΩ	20 kΩ
+30 °C	7,9 kΩ	16 kΩ
+40 °C	5,0 kΩ	10 kΩ
+50 °C	3,3 kΩ	6,8 kΩ
+60 °C	2,2 kΩ	4,3 kΩ
+70 °C	1,5 kΩ	3 kΩ

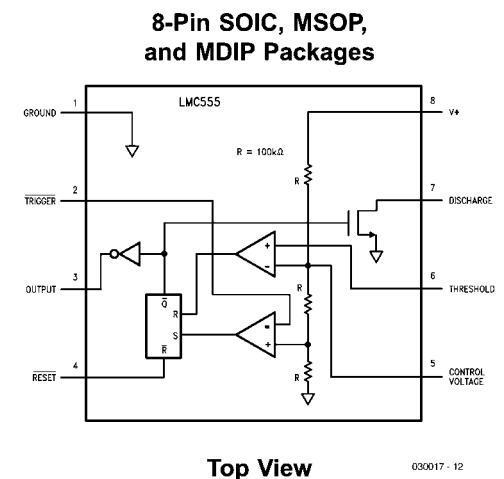

Figure 2. Internals of the 555.

COMPONENTS LIST

Resistors:

- R1 = NTC 10kΩ *
- R2 = 10kΩ *
- R3 = 2kΩ

Capacitors:

- C1 = 100nF

Semiconductors:

- D1 = LED
- IC1 = TLC555

Miscellaneous:

- S1 = pushbutton, 1 make contact
- K1 = 2 solder pins

* see text